

BOARD OF
BUILDING AND SAFETY
COMMISSIONERS

MARSHA L. BROWN
PRESIDENT

HELENA JUBANY
VICE-PRESIDENT

VAN AMBATIELOS
VICTOR H. CUEVAS

CITY OF LOS ANGELES

CALIFORNIA



ANTONIO R. VILLARAIGOSA
MAYOR

DEPARTMENT OF
BUILDING AND SAFETY
201 NORTH FIGUEROA STREET
LOS ANGELES, CA 90012

ROBERT R. "BUD" CVROM
GENERAL MANAGER

RAYMOND S. CHAN, C.E., S.E.
EXECUTIVE OFFICER

The Steel Network, Inc.
2012 TW Alexander Dr.
P.O. Box 13887
Durham, NC 27709

RESEARCH REPORT: RR 25781
(CSI # 05 40 00; 05 05 23)

BASED UPON ICC EVALUATION SERVICE
REPORT No. ESR-2049

Attn: Kristy Andrews
(919) 845-1025

REEVALUATION DUE
DATE: May 1, 2014
Issued Date: July 1, 2012
Code: 2011 LABC

GENERAL APPROVAL – Reevaluation- DriftClip® DSLB362/400, DSLB600, DSLB800, DSLS600-12, DSLS600-15, DSL362/400, DSL600, DSL800, DSLD362/400, DSLD600, DSLD800 and DriftTrak® DTSLB362/400, DTSLB400, DTSLB800 and DTSL.

DETAILS

The above assemblies and/or products are approved when in compliance with the description, use, identification and findings of ICC Evaluation Services No. ESR-2049, dated June 1, 2011, revised May 2012 of the ICC Evaluation Service, Incorporated. The report, in its entirety, is attached and made part of this general approval.

The approval is subject to the following conditions:

1. Cross section, support details and connection details of each stud or joist shall be shown on plans to be reviewed by Structural Plan Check of the Department. The plans shall bear the signature of a Civil or Structural Engineer registered in California.
2. Where exposed to the weather the connectors shall be galvanized.
3. Product shall be installed according to Section 4.2 of ESR-2049.
4. Wall assembly design wall shall comply with Section 2210.5 of the 2011 Los Angeles Building Code.

RR 25781
Page 1 of 2

The Steel Network, Inc.

Re: DriftClip® DSLB362/400, DSLB600, DSLB800, DSLS600-12, DSLS600-15, DSL362/400, DSL600, DSL800, DSLD362/400, DSLD600, DSLD800 and DriftTrak® DTSLB362/400, DTSLB400, DTSLB800 and DTSL.

5. Screws shall be in compliance with LARR.
6. Products shall be installed in accordance with this report.

DISCUSSION

The report is in compliance with the 2011 Los Angeles City Building Code.

The approval was based on test data in accordance with the ICC-ES Acceptance Criteria for Connectors Used with Cold-formed Steel Structural Members (AC261), dated February 2010.

This general approval will remain effective provided the Evaluation Report is maintained valid and unrevised with the issuing organization. Any revisions to the report must be submitted to this Department, with appropriate fee, for review in order to continue the approval of the revised report.

This general approval of an equivalent alternate to the Code is only valid where an engineer and/or inspector of this Department has determined that all conditions of this approval have been met in the project in which it is to be used.

Addressee to whom this Research Report is issued is responsible for providing copies of it, complete with any attachments indicated, to architects, engineers and builders using items approved herein in design or construction which must be approved by Department of Building and Safety Engineers and Inspectors.



ALLEN PEERY, Chief
Engineering Research Section
201 N. Figueroa St., Room 880
Los Angeles, CA 90012
Phone- 213-202-9812
Fax- 213-202-9943

 KH:kh
RR25781/MSWord2010
R07/03/12
2F3/2C/2210

Attachment: ICC-ES Evaluation Report No. ESR-2049 (4 Pages)

ICC-ES Evaluation Report

ESR-2049

Reissued December 1, 2012

This report is subject to renewal December 1, 2013.

www.icc-es.org | (800) 423-6587 | (562) 699-0543

A Subsidiary of the International Code Council®

DIVISION: 05 00 00—METALS

Section: 05 05 23—Metal Fastenings

Section: 05 40 00—Cold-Formed Metal Framing

DIVISION: 09 00 00—FINISHESSection: 09 22 16.13—Non-Structural Metal Stud
Framing**REPORT HOLDER:**

THE STEEL NETWORK, INC.
2012 T.W. ALEXANDER DRIVE
POST OFFICE BOX 13887
DURHAM, NORTH CAROLINA 27709
(919) 845-1025
www.steelnetwork.com
technicalsupport@steelnetwork.com

EVALUATION SUBJECT:**DRIFTCLIP® AND DRIFTTRAK® EXTERIOR CURTAIN
WALL CONNECTORS AND DRIFTCLIP® INTERIOR TOP-
OF-WALL CONNECTOR****1.0 EVALUATION SCOPE****Compliance with the following code:**2009 and 2006 *International Building Code*® (IBC)**Properties evaluated:**

Structural

2.0 USES**2.1 DriftClip® and DriftTrak® Exterior Curtain Wall
Connectors:**

The DriftClip® DSLB, DSLS, and DSL, and DriftTrak® DTSLB and DTSL, cold-formed steel connectors are used to attach the cold-formed steel studs of a building's exterior curtain wall to structural members, to transfer wind or seismic loads acting perpendicular to the exterior curtain wall and to accommodate vertical movement and horizontal (in-plane of wall) movement between exterior wall elements and the primary structure.

2.2 DriftClip® Top-of-wall Connector:

The DriftClip® DSLD cold-formed steel connector is used to attach the top of interior nonload-bearing steel studs (top-of-wall connection) to the building's structural floor/ceiling or roof/ceiling deck, to transfer loads acting perpendicular to the interior nonload-bearing wall and to accommodate vertical movement and horizontal (in-plane of wall) movement of the building's floor/ceiling or roof/ceiling deck.

3.0 DESCRIPTION**3.1 DriftClip® DSLB, DSLS, and DSL and DriftTrak®
DTSLB and DTSL, Exterior Curtain Wall Stud
Connector:**

3.1.1 General: DriftClip® and DriftTrak® model numbers correspond to the depth of the cold-formed steel stud attached to the DriftClip®. For example, a DriftClip® connector with a model number 362 is designed to be attached to a 3⁵/₈-inch-deep (92 mm) steel stud, where the depth of the steel stud is rounded to 3.62 inches (92 mm) and is reported as 362. Each DriftClip® and DriftTrak® exterior stud connector has two or more vertical slots with factory-installed bushings located in the center of each slot, through which a No.12, self-drilling/self-tapping steel screw supplied by the Steel Network, Inc., is installed to attach the clip to the stud, allowing horizontal loads to be transferred from the stud web to the supporting structure while allowing vertical movement of the structure with negligible friction. Each DriftClip® also has two or more horizontal slots with factory-installed bushings located in the center of each slot, through which a 1/4-inch-diameter (6.4 mm) fastener designed and specified by a registered design professional, and not supplied by the Steel Network, Inc., is installed to attach the clip to the structure, allowing horizontal loads to be transferred from the stud web to the supporting structure while allowing horizontal (in-plane of wall) movement of the structure with negligible friction. DriftTrak® consists of a clip that slides into a track component that is attached to the structure with fasteners designed and specified by a registered design professional, not supplied by the Steel Network Inc., that allows the clip component to move freely in-plane along the track allowing horizontal loads to be transferred from the stud web to the supporting structure while allowing horizontal (in-plane of wall) movement of the structure with negligible friction.

3.1.2 DriftClip® DSLB: DriftClip® DSLB362/400, 600 and 800 are L-shaped angles that connect 3⁵/₈- or 4-, 6- and 8-inch-deep (92 or 102, 152, and 203 mm) exterior curtain wall steel studs, respectively, to a concrete floor slab's pour stop angle while allowing a maximum of 2 inches (51 mm) of vertical and horizontal movement between exterior wall elements and the primary structure. The minimum base-metal thickness of the clips is 0.0966 inch (2.5 mm). The leg which matches the wall depth and is fastened to the curtain wall stud has two or three slots parallel to the heel of the angle, each 3/8 inch (9.5 mm) wide by 2³/₈ inches (60 mm) long with a bushing designed for No. 12 self-drilling/self-tapping steel screw installed in the centers of the slots. The 3¹/₄-inch (95 mm) leg, which is fastened to the structure, has bushings designed a for

$\frac{1}{4}$ -inch-diameter (6.4 mm) fastener installed in the center of each slot. Refer to Figure 1 for overall dimensions of each DriftClip[®] DSLB connector and a typical installation detail.

3.1.3 DriftClip[®] DSLS: DriftClip[®] DSLS600-12 and DSLS600-15 are L-shaped angles that connect 6-inch-deep (152 mm) cold-formed steel framing of exterior curtain walls to a building's structural steel spandrel beam or structural concrete floor slab, while allowing a maximum of 2 inches (51 mm) of vertical and horizontal movement between curtain wall elements and the primary structure. The minimum base-metal thickness of the clips is 0.0966 inch (2.5 mm). The -12 and -15 following the model number DSLS600 represent the total length, in inches, of the connector. The two legs of the DriftClip[®] DSLS600-12 and -15 connectors are equal in length, and each has two or three slots perpendicular to the heel of the angle, each $\frac{3}{8}$ inch (9.5 mm) wide by $2\frac{3}{8}$ inches (60 mm) long. The leg which is fastened to the curtain wall stud has bushings designed for No. 12 self-drilling/self-tapping steel screws installed in the centers of the slots. The other leg, which is fastened to the structure, has bushings designed for $\frac{1}{4}$ -inch-diameter (6.4 mm) fasteners installed in the centers of the slot. Refer to Figure 2 for overall dimensions of each DriftClip[®] DSLS connector and a typical installation detail.

3.1.4 DriftClip[®] DSL: DriftClip[®] DSL362/400, 600 and 800 are L-shaped angles that connect $3\frac{5}{8}$ - or 4-, 6- and 8-inch-deep (92 or 102, 152, and 203 mm) exterior curtain wall steel studs, respectively, at head of wall to the building's structural frame while allowing for a maximum of 2 inches (51 mm) of vertical, and horizontal movement between exterior wall elements and the primary structure. The minimum base-metal thickness of the clips is 0.0966 inch (2.5 mm). The two legs of the DriftClip[®] DSL362/400, 600 and 800 connectors are equal in length, and each has two or three slots perpendicular to the heel of the angle, each $\frac{3}{8}$ inch (9.5 mm) wide by $2\frac{3}{8}$ inches (60 mm) long. The leg which is fastened to the curtain wall stud has bushings designed for No. 12 self-drilling/self-tapping steel screws installed in the center of each slot. The other leg, which is fastened to the structure, has bushings designed for $\frac{1}{4}$ -inch-diameter (6.4 mm) fasteners installed in the centers of the slots. Refer to Figure 3 for overall dimensions of each DriftClip[®] DSL connector and a typical installation detail.

3.1.5 DriftTrak[®] DTSLB: DriftTrak[®] DTSLB362/400, 600 and 800 are L-shaped angle and track combinations that connect $3\frac{5}{8}$ - or 4-, 6- and 8-inch-deep (92 or 102, 152, and 203 mm) exterior curtain wall steel studs, respectively, to a concrete floor slab's pour-stop angle while allowing a maximum of 2 inches (51 mm) of vertical movement, and free horizontal movement between exterior wall elements and the primary structure. The minimum base-metal thickness of the clip is 0.0677 inch (1.7 mm), and the minimum base-metal thickness of the track is 0.0966 inch (2.5 mm). The long leg of the DriftTrak[®] DTSLB connector, which is fastened to the curtain wall stud, has two or three vertical slots, each $\frac{3}{8}$ inch (9.5 mm) wide by $2\frac{3}{8}$ inches (60 mm) long and has bushings designed for No. 12 self-drilling/self-tapping steel screws installed in the centers of the slots. Refer to Figure 4 for overall dimensions of each DriftClip[®] DTSL connector and a typical installation detail.

3.1.6 DriftTrak[®] DTSL: The DriftTrak[®] DTSL is an L-shaped angle and track combination that connects exterior curtain wall steel studs of various depths at head of wall to the building's structural frame while allowing for a maximum of 2 inches (51 mm) of vertical movement, and free horizontal movement between exterior wall elements

and the primary structure. The minimum base-metal thickness of the clip is 0.0677 inch (1.7 mm) and the minimum base-metal thickness of the track is 0.0966 inch (2.5 mm). The long leg of the DriftTrak[®] DTSL connector, which is fastened to the curtain wall stud, has two vertical slots, each $\frac{3}{8}$ inch (9.5 mm) wide by $2\frac{3}{8}$ inches (60 mm) long, and has bushings designed for No. 12 self-drilling/self-tapping steel screws installed in the centers of the slots. Refer to Figure 5 for overall dimensions of each DriftTrak[®] DTSL connector and a typical installation detail.

3.2 DriftClip[®] DSLD Interior Top-of-Wall Stud Connectors:

DriftClip[®] DSLD362/400, 600 and 800 are L-shaped angles that connect $3\frac{5}{8}$ - or 4-, 6- and 8-inch-deep (92 or 102, 152, and 203 mm) interior wall steel studs, respectively, at head of wall to a metal deck above, while allowing for a maximum of 2 inches (51 mm) of vertical movement, and horizontal (in-plane of wall) movement between interior wall elements and the primary structure. The minimum base-metal thickness of the clips is 0.0329 inch (0.8 mm). The two legs of the DriftClip[®] DSLD362/400, 600 and 800 connectors are equal in length, and each has two or three slots perpendicular to the heel of the angle, each $\frac{3}{8}$ inch (9.5 mm) wide by $2\frac{3}{8}$ inches (60 mm) long, with bushings designed for No. 8 self-drilling/self-tapping steel screws installed in the centers of the slots. Refer to Figure 6 for overall dimensions of each DriftClip[®] DSLD connector and a typical installation detail.

3.3 Materials:

3.3.1 DriftClips[®] and DriftTraks[®]: The DriftClip[®] and DriftTrak[®] connectors described in this report are manufactured from ASTM A 653/A 653M, Grade 50 steel having a minimum 50 ksi (340 MPa) yield strength and a minimum 65 ksi (450 MPa) tensile strength. There is a minimum G90 zinc-coating designation for DriftClip[®] DSL, DSLB, DSLS and the clip component of the DriftTrak[®] DTSL and DTSLB Exterior Curtain Wall Stud Connectors, and a minimum G60 zinc-coating designation for the DriftClip[®] DSLD Interior Curtain Wall Stud Connectors and the track component of the DriftTrak[®] DTSL and DTSLB.

3.3.2 Bushings: The bushings are proprietary and factory-installed on each DriftClip[®] and DriftTrak[®] product, and are not available separately for field installation. The bushings through which the attachment to the stud is made for all DriftClip[®] and DriftTrak[®] clips and through which the attachment to the structure is made for DriftClip[®] DSLD are manufactured from carbon steel conforming to ASTM B 783-04, F-0008-35, having a minimum specified yield strength of 35 ksi (240 MPa) as stipulated in the approved quality control manual. The bushings through which the attachment to the structure is made for DriftClip[®] DSL, DSLB, and DSLS are manufactured from ASTM A 576, Grade 12L14 steel as stipulated in the approved quality control manual.

3.3.3 Screws: Screws used with DriftClip[®] and DriftTrak[®] series for the attachment to the stud must be self-drilling/self-tapping steel screws, as follows:

- The No. 8 self-drilling tapping screws used with the DriftClip[®] DSLD362/400, DSLD600, and DSLD800 must have a minimum nominal screw shear strength, P_{ss} , of 1,330 pounds (5915 N).
- The No. 12 self-drilling tapping screws used with the DriftClip[®] DSLB362/400, DSLB600, DSLB800, DSLS600-12, DSLS600-15, DSL362/400, DSL600, DSL800, and DriftTrak[®] DTSLB362/400, DTSLB600, DTSLB800 and DTSL, must have a minimum nominal screw shear strength, P_{ss} , of 2400 pounds (10 673 N).

3.3.4 Cold-formed Steel Studs: The available strength loads specified in Table 1 are applicable to connections with steel studs fabricated from cold-formed steel complying with ASTM A1003/A 1003M Grade ST50H, having a minimum base-metal thickness of 0.0966 inch (2.5 mm).

4.0 DESIGN AND INSTALLATION

4.1 Design:

The connection of the DriftClip® and DriftTrak® products to the supporting structure must have a design strength (LRFD) or allowable strength (ASD) not less than the available strength assigned to the DriftClip® or DriftTrak® products in Table 1 of this report.

The DriftClip® and DriftTrak® products have not been evaluated to support the dead load of framing and cladding. A method to support the dead load of the wall framing and cladding must be submitted to the code official for approval.

When using the alternate basic load combinations in IBC Section 1605.3.2 that include wind or seismic loads, the ASD allowable strength in Table 1 for the DriftClip® and DriftTrak® connectors must not be increased by 33¹/₃ percent, nor must the alternative basic load combinations be reduced by a factor of 0.75. When using the basic load combinations in accordance with IBC Section 1605.2.1, the LRFD design strength in Table 1 for the DriftClip® and DriftTrak® connectors must not be increased for wind or seismic loading.

If the steel studs connected to DriftClip® and DriftTrak® connectors have lower base-metal thickness or material strength values than specified in Section 3.3.4, the ASD allowable strength or the LRFD design strength of the steel-stud/connector-screw connection may be calculated according to the AISI cold formed steel specification referenced by the AISI S100-07 under the 2009 IBC or NAS-01, including the 2004 Supplement, under the 2006

IBC, but not to exceed the corresponding loads listed in Table 1.

4.2 Installation:

Installation of the DriftClip® and DriftTrak® products must comply with this report and the manufacturer's published installation instructions.

5.0 CONDITIONS OF USE

The DriftClip® and DriftTrak® products described in this report comply with, or are suitable alternatives to what is specified in, those codes listed in Section 1.0 of this report, subject to the following conditions:

5.1 Drawings and design details verifying compliance with this report must be submitted to the building official for approval. The drawings and calculations must be prepared by a registered design professional when required by the statutes of the jurisdiction in which the project is to be constructed.

5.2 The products must be installed in accordance with this report and the manufacturer's published installation instructions. If there is a conflict between this report and the manufacturer's published installation instructions, this report governs.

6.0 EVIDENCE SUBMITTED

Data in accordance with the ICC-ES Acceptance Criteria for Connectors Used with Cold-formed Steel Structural Members (AC261), dated December 2010.

7.0 IDENTIFICATION

The DriftClip® and DriftTrak® products described in this report must be stamped, labeled, or inked with the product designation and the company name (The Steel Network, Inc.). Each box label must include the company name (The Steel Network, Inc.), product designation/part name, quantity, the ICC-ES evaluation report number (ESR-2049), and a traveler (tracing) number.

TABLE 1—DRIFTCLIP® AND DRIFTTRAK® ALLOWABLE STRESS DESIGN (ASD), LOAD RESISTANCE FACTOR DESIGN (LRFD) STRENGTH, AND DEFLECTION SERVICE LIMIT LOADS¹

DRIFTCLIP/ DRIFT TRACK MODEL	SCREWS TO STUD (Quantity) AND SIZE ²	FIGURE	ASD ALLOWABLE STRENGTH ³ (lbs)	LRFD DESIGN STRENGTH (lbs)	SERVICE LIMIT LOAD (lbs) ⁴
DSL362/400, 600, 800	(2) #12 for DSL362/400 (3) #12 for DSL600, 800	1	572	916	735
DSLS600-12	(3) #12	2	1,742	2,787	2,084
DSLS600-15	(3) #12	2	1,903	3,044	2,958
DSL362/400	(2) #12	3	248	397	129
DSL600	(3) #12	3	776	1,241	418
DSL800	(3) #12	3	1,041	1,665	1,510
DSL362/400	(2) #8	6	053	085	027
DSL600	(2) #8	6	178	285	107
DSL800	(2) #8	6	183	294	325
DTSL362/400, 600, 800	(2) #12 for DSL362/400 (3) #12 for DSL600, 800	4	808	1,293	1,304
DTSL	(2) #12	5	482	771	492

For SI: 1 lbf = 4.45 N.

Notes to Table 1:

¹Refer to Figures 1 through 6 for direction of load.

²Screws must comply with Section 3.3.3 of this report, and must be installed in the prepunched holes and bushings provided in the connectors.

³When using the alternate basic load combinations in IBC Section 1605.3.2 that include wind or seismic loads, the tabulated ASD allowable strength for the DriftClip[®] and DriftTrak[®] connectors may not be increased by 33¹/₃ percent, nor must the alternative basic load combinations be reduced by a factor of 0.75.

⁴The Service Limit Load is the average test load at a ³/₁₆-inch deflection service limit for DriftClip[®] (DLSL, DSL, DSLD, and DSLB) connectors and the average test load at a ¹/₈-inch deflection service limit for DriftTrak[®] (DTSLB and DTSL) connectors. The service limit is applicable to both ASD and LRFD.

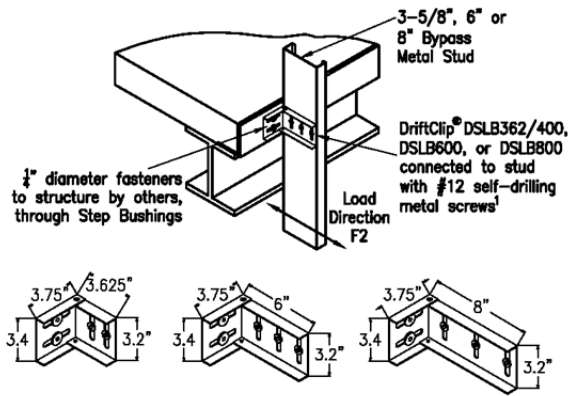

Figure 1 – DriftClip[®] DSLB362/400, DSL600 and DSLB800

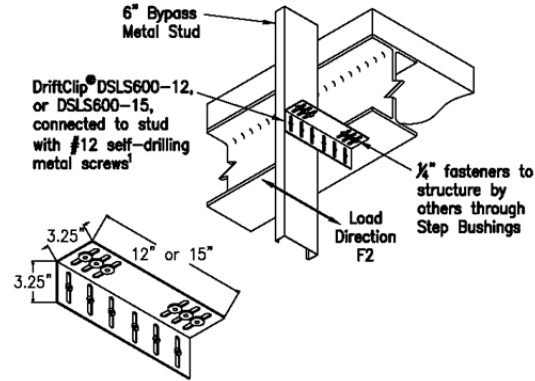

Figure 2 – DriftClip[®] DLSL600-12 and DLSL600-15

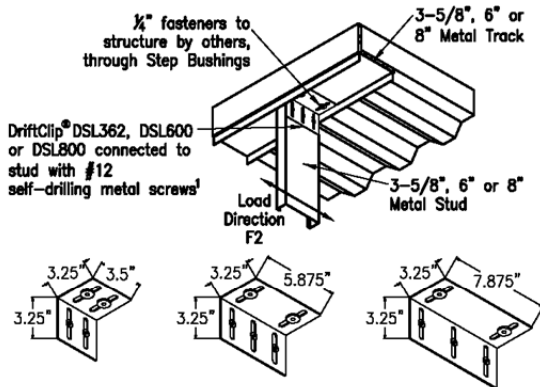

Figure 3 – DriftClip[®] DSL362/400, DSL600 and DSL800

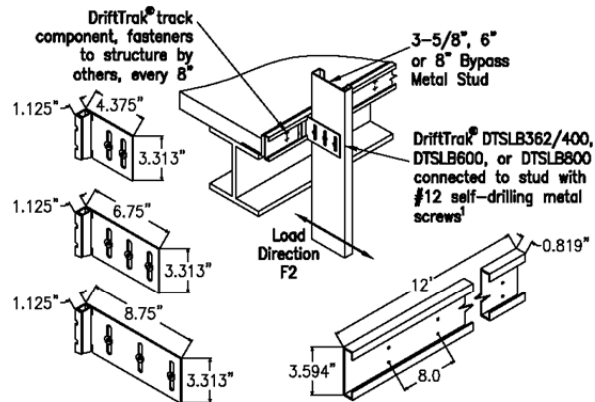

Figure 4 – DriftTrak[®] DTSLB362/400, DTSLB600 and DTSLB800

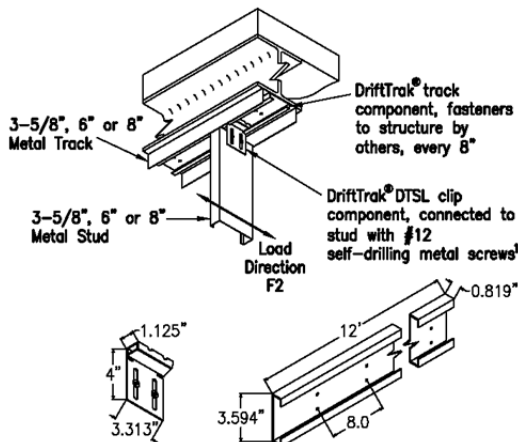

Figure 5 – DriftTrak[®] DTSL

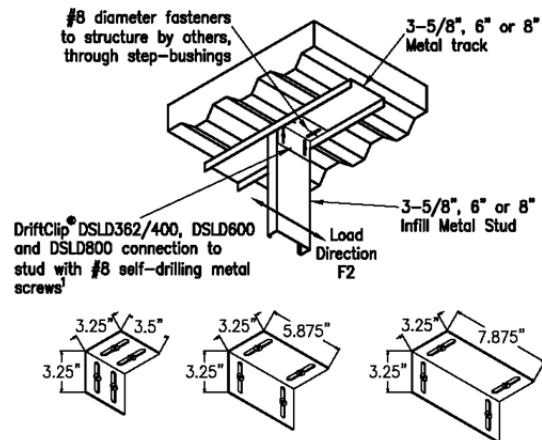

Figure 6 – DriftClip[®] DSLD362/400, DSLD600 and DSLD800

¹ Refer to Sec. 4.1 for connector/stud screw connection strength evaluation.