

DriftTrak® DTSLB

Bypass Slab



Material Composition

Clip Material: ASTM A1003/A1003M Structural Grade 50 (340) Type H, ST50H (ST340H): 50ksi (340MPa) minimum yield strength, 65ksi (450MPa) minimum tensile strength, 68mil minimum thickness (14 gauge, 0.0713" design thickness) with ASTM A653/A653M G90 (Z275) hot dipped galvanized coating.

Track Material: ASTM A1003/A1003M Structural Grade 50 (340) Type H, ST50H (ST340H): 50ksi (340MPa) minimum yield strength, 65ksi (450MPa) minimum tensile strength, 97mil minimum thickness (12 gauge, 0.1017" design thickness) with ASTM A653/A653M G60 (Z180) hot dipped galvanized coating.

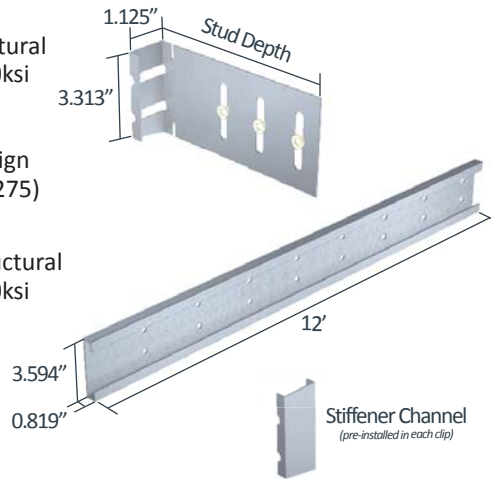

US Patents #7,503,150 & #7,104,024

DriftTrak DTSLB Allowable (Unfactored) Loads¹

DriftTrak® DTSLB, Recommended Allowable Load (lbs): F2					
Stud		Fastener Pattern 1 & 2			
		8" Fastener Spacing in Track to Structure (or welded on each side)		16" Fastener Spacing in Track to Structure (or welded on each side)	
Thickness Mils (ga)	Yield Strength (ksi)	w/2 #12 Screws	w/3 #12 Screws	w/2 #12 Screws	w/3 #12 Screws
33 (20)	33	377	565	377	565
33 (20)	50	544	808	544	753
43 (18)	33	561	808	561	753
43 (18)	50	808	808	753	753
54 (16)	33	789	808	753	753
54 (16)	50	808	808	753	753
68 (14)	50	808	808	753	753
97 (12)	50	808	808	753	753
Maximum Allowable Clip Load		808	808	753	753

Notes:

- Design loads are for attachment of DriftTrak DTSLB to stud only. Load tables reflect horizontal loads (F2).
- Attachment to structure engineered by others.
- Allowable loads have not been increased for wind, seismic, or other factors.
- #12 screws are provided with each step bushing for attachment to stud. Load requirements don't always justify use of a third screw.
- Clips are manufactured to fit into the DriftTrak and provide up to 2" of vertical deflection (1" up and 1" down), and free lateral movement of the structure.
- Allow a minimum of 0.875" from the structure to the inside flange of the bypassing stud to allow for track attachment.
- One row of bridging is recommended at a maximum distance of 12" from DriftTrak to resist torsional effects.

¹ For LRFD Design Strengths refer to ICC-ESR-2049.

Load Direction



Nomenclature

DriftTrak DTSLB is classified by multiplying stud depth by 100.

Example: 6" stud depth

Designate: DriftTrak® DTSLB600

Fastener Patterns

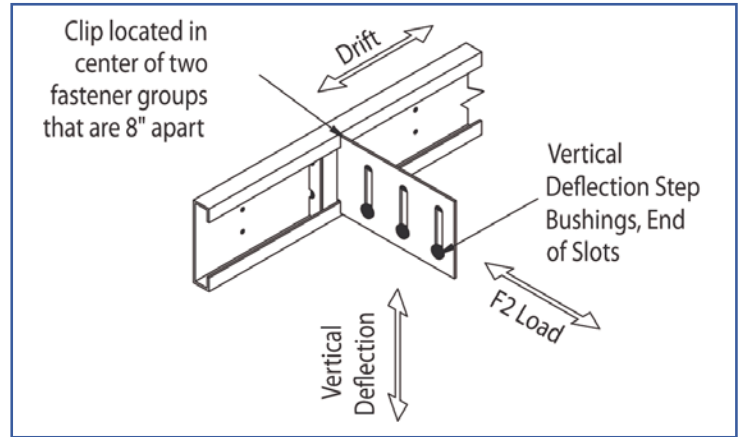
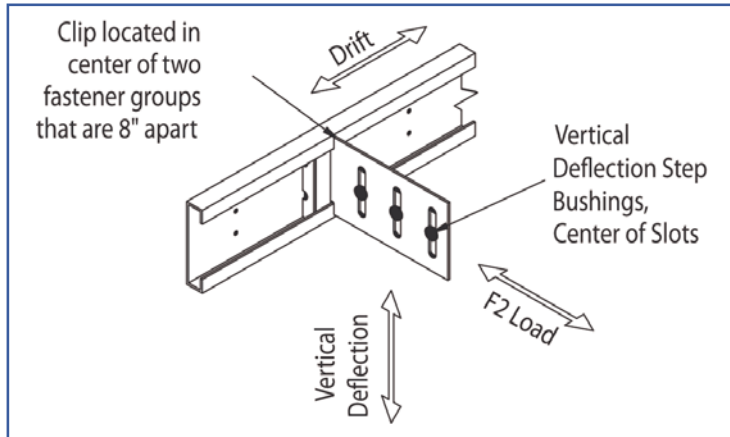

Fastener Pattern 1 replicates a condition of out-of-plane wind or seismic force with no vertical live load deflection and full in-plane drift.

Fastener Pattern 2 replicates a condition of out-of-plane wind or seismic force with full vertical live load deflection and full in-plane drift.



DriftTrak DTSLB
ICC-ESR-2049
www.icc-es.org



DriftTrak DTSLB Series
LARR #25781
www.ladbs.org

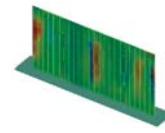

DriftTrak DTSLB Series
Blast and Seismic Design data
www.steelnetwork.com

** For more information or to review a copy of each of these reports, please visit our website at <http://www.steelnetwork.com/Site/TechnicalData>