

QUALITY LIGHT STEEL FRAMING CONNECTIONS AND MEMBERS

LIGHT STEEL FRAMING CONNECTIONS

INTERIOR · EXTERIOR · VERTICAL DEFLECTION · DRIFT

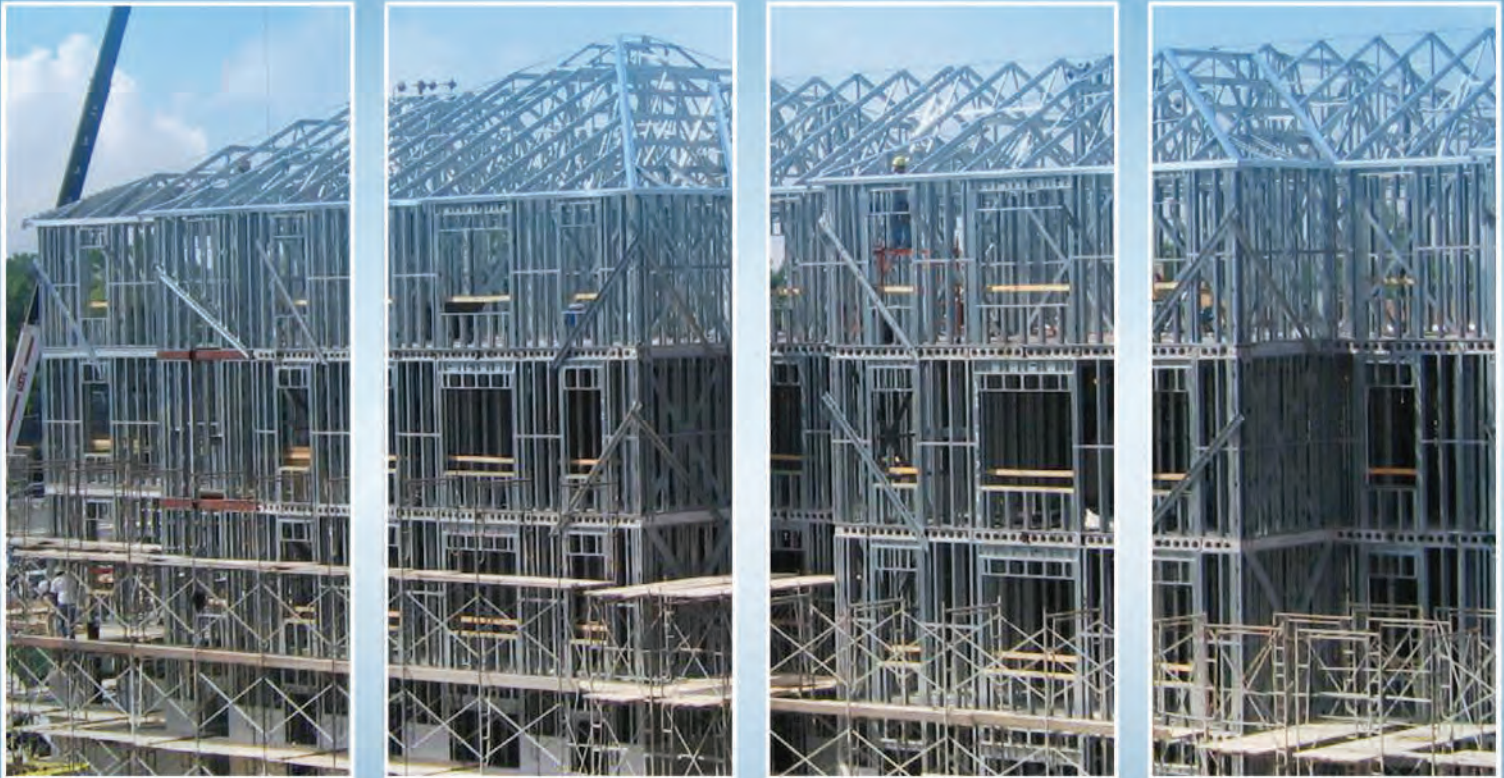

STEELNETWORK.COM
1.888.474.4876

Light Steel Framing Connections

Table of Contents

General Product Information.....	2
Building Load Paths.....	3
Movement-Allowing Connectors/Step Bushing Technology®.....	4
Vertical Deflection: Head Of Wall Connectors	
VertiTrack® VTD (Interior).....	5-6
VertiTrack® VTX (Exterior).....	7-8
VertiClip® SLD (Interior).....	9-10
VertiClip® SL (Exterior).....	11-12
VertiClip® SLD w/ 3" Slots (Interior).....	13
VertiClip® SL w/ 3" Slots (Exterior).....	14
Vertical Deflection: Bypass Connectors	
VertiClip® SLS (Bypass Structure).....	15-16
VertiClip® SLB (Bypass Slab).....	17-18
VertiClip® SLB-HD (Seismic Bypass Slab).....	19
VertiClip® SLF (Bypass Slab - Panels).....	20
VertiClip® SLT (Structure/Slab Bypass).....	21-22
Hybrid Vertical Deflection & Rigid Connectors	
MasterClip® VLB (Bypass Slab).....	23-24
Drift and Vertical Deflection Connectors	
DriftClip® DSLB (Bypass Slab).....	25-26
DriftClip® DSLS (Bypass Structure).....	27-28
DriftClip® DSLD (Interior Head of Wall).....	29-30
DriftClip® DSL (Exterior Head of Wall).....	31-32
DriftTrak® DTSL (Exterior Head of Wall).....	33-34
DriftTrak® DTSLB (Exterior Bypass).....	35-36
DriftTrak® DTLB (Exterior Bypass).....	37-38
DriftTrak® Headed Stud (Slab Integrated Bypass).....	39-40
DriftTrak® Headed Stud - PTS (Slab Integrated Bypass).....	41-42
Wall Bridging Connectors	
Wall Bridging Background.....	44
Curtain Wall Bridging Reference Chart.....	45-46
Wall Bridging Anchorage.....	47
BridgeClip® (Secures Channel to Stud).....	48
BridgeBar® (Bridging Channel).....	49
BuckleBridge® (Bridging System).....	50
Rigid Wall Connectors	
StiffClip® LB (Spandrel Bypass).....	51-52
StiffClip® LB-HD (Seismic Spandrel Bypass).....	53
VertiClip® Splice (Multi-Stud Clip).....	54
StiffClip® CL (Tie-Down).....	55-56
MidWall™ (Partial Wall Framing).....	57-58
StiffClip® TD (Tie-Down).....	59-60
StiffClip® PLC (Panel Lift Clip).....	61-62
StiffClip® HE (Header Clip).....	63-64
StiffClip® HS (Jamb Stud Header and Sill Connector).....	65
Rigid Roof & Truss Connectors	
StiffClip® HC (Hip Connector).....	66
StiffClip® RT (Roof Tie).....	67-68
StiffClip® WC (Web Connector).....	69-70
StiffClip® PL (Truss Connector).....	71
Floor Connectors	
StiffClip® JH (Joist Hanger).....	72
StiffClip® JC (Joist Clip).....	73
StiffClip® FS (Floor Strap).....	74
All-Purpose Rigid Connectors & Specialty Products	
StiffClip® AL (Multi-Purpose).....	75-76
StiffClip® LS (Spandrel/Multi-Purpose).....	77
CircleTrak® (Curved Wall Track).....	78
NotchTrak® NT (Wall Backing/Bridging).....	79-80
BackIt® (Wall Backing).....	81
GripClip® (Column/Beam Connector).....	82
Common Clip Angle.....	83
Custom Connectors.....	84
Special Design Requirements	
Blast & Seismic Design Load Tables.....	85-86
Building Codes & Fire Ratings.....	87

General Product Information

Introduction

The Steel Network provides solutions for all standard light steel framing configurations. Substantial effort has been made by the industry to standardize construction practices to ensure the positive connections of light steel framing components. Toward this end, TSN products have undergone extensive field and laboratory testing to achieve complete solutions for both designers and installers. Product test reports may be ordered by contacting TSN engineering at (888) 474-4876.

- Attachment of connections to the primary structure should be engineered by a design professional. Listed allowable loads are based on tests with full attachment to primary structure through all guide holes where applicable.
- Prying action on the attachment to the structure should be considered where eccentricity exists between the fastener and the load.
- Test reports are available through The Steel Network, Inc. Contact TSN at (888) 474-4876 for more information.
- The Steel Network, Inc. offers all products and services through local authorized distributors.
- Products are manufactured from recycled steel. 
- The installation contractor is responsible for installing products in accordance with the instructions listed in this catalog and included with the shipped product, in addition to any relevant specifications and building codes. Install connectors prior to loading.
- Custom products are available upon request. Prior approval must be obtained and the order shall be submitted with a signed engineered drawing.
- Allowable loads and material data listed in this catalog supersede all information in all earlier publications.
- Self-drilling screws should be installed perpendicular to the work surface with a screw gun limited to no more than 2,500 rpm.
- The screw gun must also feature a torque limiting nose piece to avoid over-driving the screw. Over-driving can damage the fastener by stripping the threads or shearing the fastener head and may cause failure even when not visually detected.
- Allowable loads have not been increased for wind, seismic, or other factors.
- Loads are determined using "Allowable Stress Design" (ASD) method. When LRFD (Load and Resistance Factor Design) is utilized, contact TSN for appropriate resistance values.
- Products are tested according to the guidelines listed in the AISI Specification for the Design of Cold Formed Steel Structures, Section K, and ICC Criteria AC261, where applicable.
- Allowable loads are based on the lesser of: (a) Average test ultimate load divided by the appropriate factor of safety, (b) Load producing deflection value of 0.125" for vertical deflection products and 0.1875" or drift products, or (c) Fastener/screw allowable load between the clip & stud.
- Allowable loads are the result of static testing by either independent testing facilities or in-house testing and calculations.
- Allowable loads are the maximum forces resisted in one direction only. When multiple loads effect a connection: Designer of record is responsible for checking the interaction of multiple loads acting on a connection.
- Screw connection allowable loads are based on AISI-S100 design specification, Sec. J4, and are limited by these allowable loads: 777 lbs for #12 Shear, 548 lbs for #10 Shear, 427 lbs for #8 Shear, 494 lbs for #12 Pullout, 435 lbs for #10 Pullout, 375 lbs for #8 Pullout.
- Where screw torsion is considered, it is assumed that half of the torsional moment is taken by the connection to the structure and half is taken by the connection to the stud, unless stated otherwise.

SteelSmart System 8

With 2015 IBC & ASCE 7-10

The industry's **#1 tool** for the design of
Connections, Members, Fasteners & Details

COMPONENT DESIGN MODULES:

- Curtain Wall
- Floor Framing
- Load Bearing Wall
- Roof Framing & Trusses
- X-Brace Shear Wall
- Moment Resisting Short Wall

ORDER ONLINE

www.steelSMARTsystem.com



Building Load Paths

Introduction

Background

There are two types of light steel framing connections, fixed and movement-allowing. Fixed connections of framing members are found in many types of assemblies, including axial-load-bearing walls, curtain walls, trusses, roofs, and floors. As light steel framing (LSF) assemblies are only as strong as their weakest component, The Steel Network has developed products to provide designers and installers with tested, certified, and traceable materials for light steel framing assemblies.

Tracing a consistent load and movement paths from the roof to the foundation is much simpler through use of The Steel Network's connectors. TSN products are engineered to provide the most efficient load transfer path for the designer while adding economies of value for the contractor.

When considering liability concerns, connections should not be the weakest part of the assembly. Use of generic material raises questions about performance. Is the steel material traceable? Is the material sufficiently galvanized? Has the material been structurally load tested? These questions should not go unanswered in today's construction practice. The Steel Network provides mill certified and tested steel, galvanized with coating meeting or exceeding industry standards, and all standard connectors are structurally load tested. TSN products have undergone extensive field and laboratory testing to achieve complete solutions for both designers and installers, enabling them to trace the most efficient load and movement paths through the structure. When it comes to connections and members, TSN is setting the industry standard.

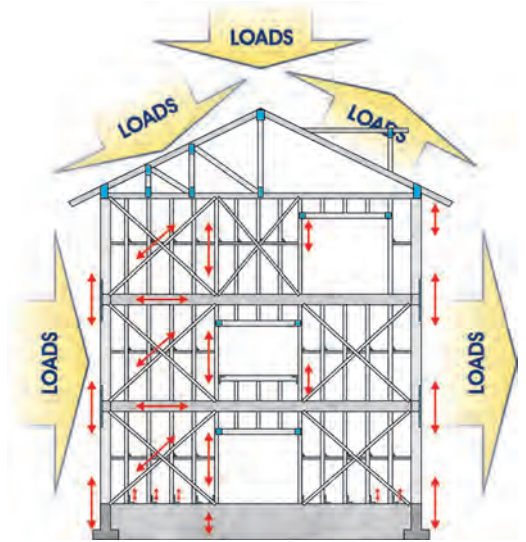

Load Directions

Connection loads have been determined through structural testing based on guidelines set forth by the AISI Specification. A diagram of load directions for each clip is located with the respective product load tables. Load direction nomenclature is consistent throughout this catalog. The diagrams at right illustrate examples of load directions used in this catalog.

F1 = Lateral (In the plane of the wall), lbs

F2 = Horizontal Load (Out of the plane of the wall), lbs

F3 = Vertical Load (or Uplift), lbs

M1 = Moment-Carrying (or Rotational), in-lbs

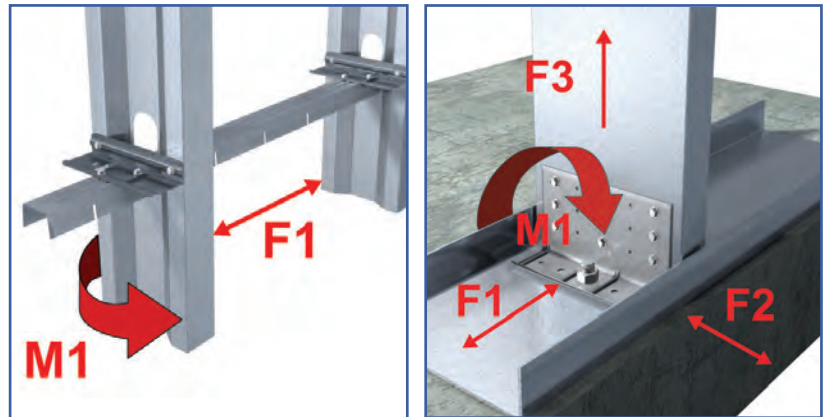

In addition, connectors are available to resist axial tension and compression in a flat plane.

Industry Improvements

The Steel Network's series of connectors utilizes tested, mechanical configurations to resist many different types of load (vertical, horizontal, tension, moment-carrying, axial tension and compression in a flat plane). Each is available in a wide range of sizes and applications to meet all standard construction needs. Additionally, custom clips may be designed and produced for specific applications.

The Steel Network delivers a comprehensive improvement to the industry by:

- Providing simple, labor-saving solutions for all steel framing attachments to primary frames.
- Placing pre-drilled guide holes for quick and accurate fastener placement.
- Producing connections tested under AISI guidelines.
- Manufacturing from ASTM A1003 grade 50 steel with hot-dipped galvanized G90 coating guaranteeing longterm durability and performance.
- Eliminating use of untested, untraceable, steel for connections.

Stiffened Plate Elements

Most TSN connection products are manufactured with stiffeners, as bending forces are present when loads are transferred from the framing member to the structure. Stiffeners increase the capacity of flat elements to resist bending, thus maximizing material efficiency.

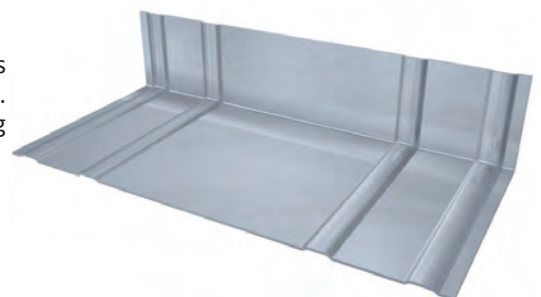

Movement-Allowing Connectors

Introduction

Primary Structural Deflection

All structures deflect vertically. To prevent non-axial-load-bearing studs from carrying the weight of the structure and to protect finishes, vertical deflection connections should be incorporated at the earliest possible moment of project design. The load-carrying capacity of a steel stud in bending is reduced significantly when adding an axial force propagated by the bending of a primary beam or slab. VertiClip® was developed to prevent the crushing effect on non-axial-load-bearing wall studs. Non-axial-load-bearing wall studs include exterior curtain wall and interior wall assemblies. When project conditions dictate, lateral drift and vertical deflection may be accommodated through utilization of TSN's DriftClip® and DriftTrak® lines of connectors.

Finished walls frequently experience cracking, buckling, or crushing due to improper isolation of building movement. The movement of the primary building structure is largely accounted for in horizontal member live loading. In addition to live loads, wind, seismic forces, moisture content in materials, and temperature cycles all contribute to movement. The incorporation of vertical deflection connections during the working drawing phase will eliminate the liability of failures and added costs associated with wall system installation.

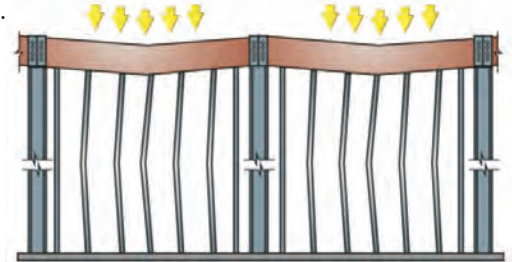

Specifying Deflection Distances

Deflection distances are determined from movement of the primary frame, roof, and floor slab. Designers of non-axial-load-bearing framing typically allow for a minimum of 1/2" (13mm) of vertical deflection. When specifying vertical deflection distances, consider the following example -- the deflection distance may be derived using a column spacing of 20 feet on center and a maximum deflection of L/480, thereby resulting in a vertical deflection value equal to .5". Deflection distances may range from 0.125" in very heavy rigid structures to 6" in lightweight open frames.

Step Bushing Technology®

Innovation

Shear Transfer

Non-axial-load-bearing walls are not designed to carry the structure, but horizontal loads from wind and seismic forces transfer from the exterior finishes through wall framing to the primary structure. VertiClip and DriftClip effectively transfer the shear load from the stud to the primary member by connecting to the stud web.

The image on the right illustrates the horizontal load path. The load transitions into shear at the VertiClip to stud web attachment. VertiClip prevents the track flange from bending and stiffens the stud web.

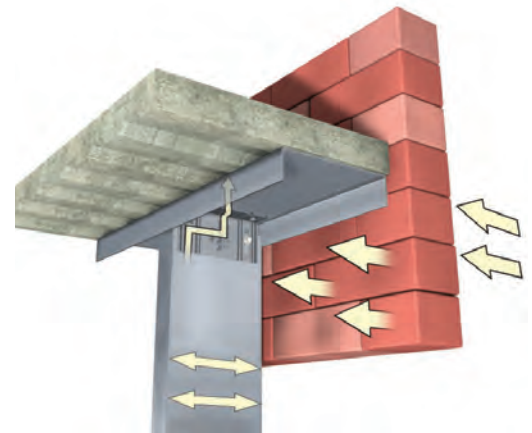

Step Bushing Technology®

Step Bushing Technology provides a solid and simple solution. Elongated slots in the connector allow for movement of the primary structure. A step bushing is pre-installed at the center of each slot. A VertiClip or DriftClip attaches mechanically to the stud web through the step bushing with self-drilling screws provided with each clip.

The Step Bushing allows horizontal loads to transfer from the stud web into the structure through a positive, mechanical attachment, while simultaneously allowing friction-free vertical movement. TSN's solutions replace friction-held configurations and flange gripping devices, further reducing liability concerns.

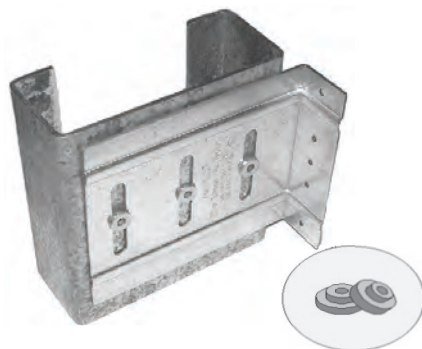

VertiClip SLB showing Step Bushings, which are pre-installed at the center of each slot and placed in position at the factory for quality assurance and ease of installation.



Allows for the shear load to be transferred at the stud web to the primary structure.

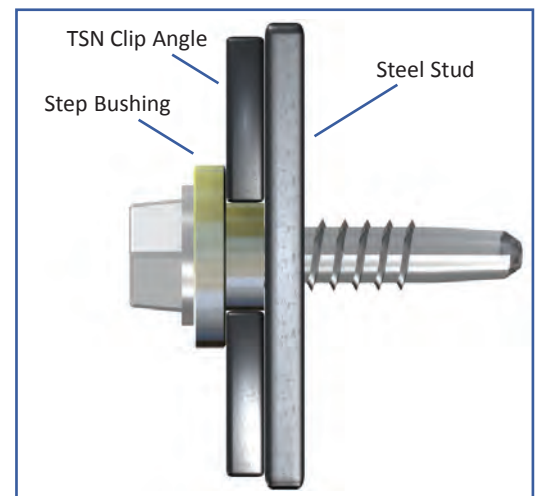

Step Bushing is seated inside slotted hole of the VertiClip. Step Bushing is slightly thicker than the steel material thus simultaneously providing a positive mechanical attachment to the stud web while allowing for slip movement.

VertiTrack® VTD

Interior Head of Wall

Material Composition

Clip Material: ASTM A1003/A1003M Structural Grade 50 (340) Type H, ST50H (ST340H): 50ksi (340MPa) minimum yield strength, 65ksi (450MPa) minimum tensile strength, 33mil minimum thickness (20 gauge, 0.0346" design thickness) with ASTM A653/A653M G60 (Z180) hot dipped galvanized coating.

Track Material: ASTM A1003/A1003M Structural Grade 33 (230) Type H, ST33H (ST230H): 33ksi (230MPa) minimum yield strength, 45ksi (310MPa) minimum tensile strength, 33mil minimum thickness (20 gauge, 0.0346" design thickness) with ASTM A653/A653M G60 (Z180) hot dipped galvanized coating.

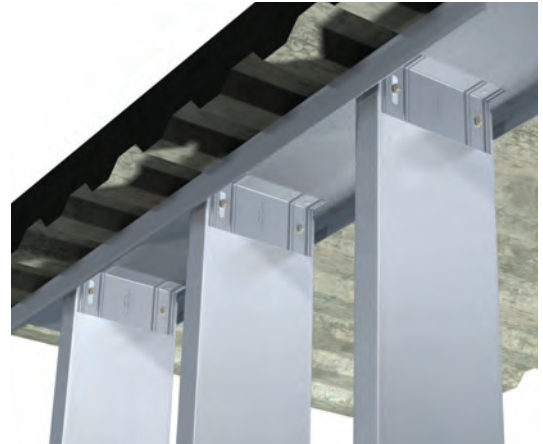
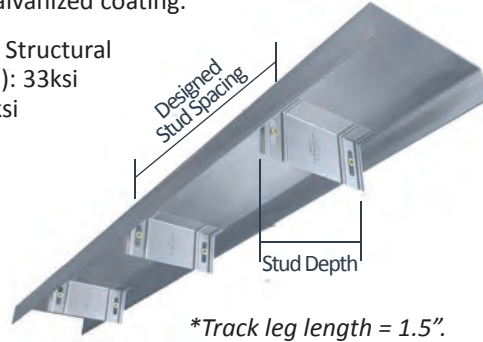

US Patents #5,467,566 & #5,906,080

The attachment of VertiTrack to the primary structure may be made with PAFs, screw/bolt anchors or weld and is dependent upon the base material (steel or concrete) and the design configuration.

VertiTrack VTD Allowable (Unfactored) Loads¹

VertiTrack® VTD, Recommended Allowable Load (lbs): F2 (VertiClip® SLD Loads)					
Stud		VTD250	VTD362/400	VTD600	VTD800
Thickness Mils (ga)	Yield Strength (ksi)	w/2 #8 screws	w/2 #8 screws	w/2 #8 screws	w/2 #8 screws
18 (25)	33	132	132	132	132
27 (22)	33	159	243	243	243
33 (20)	33	159	328	328	328
33 (20)	50	159	359	405	474
43 (18)	33	159	359	405	489
43 (18)	50	159	359	405	664
54 (16)	33	159	359	405	664
54 (16)	50	159	359	405	664
Maximum Allowable Clip Load		159	359	405	682

Load Direction

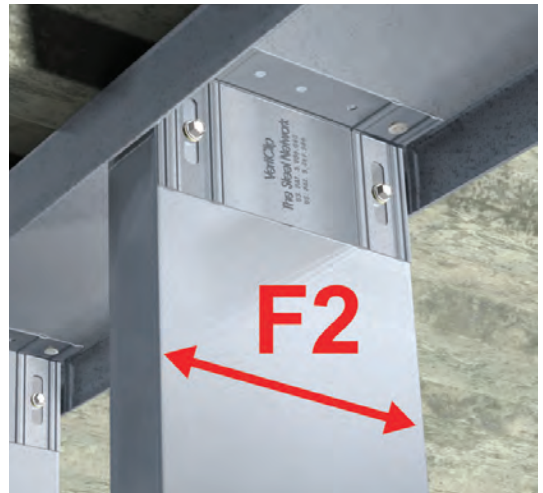

Notes:

- VertiTrack VTD loads are the same as VertiClip SLD.
 - VertiTrack VTD is assembled with VertiClip SLD pre-attached at 16" o.c. and 24" o.c.
 - Total vertical deflection of up to 1½" (¾" up and ¾" down). Deflection requirements greater than ¾" (up and down) are available. Custom spacing is also available.
 - Fasten within ¾" from the angle heel (centerline of the 1½" leg) to minimize eccentric load transfer.
 - Fasten through each VertiClip SLD to structure.
 - VertiTrack VTD series is designed to support horizontal loads, and should not be used in axial-load-bearing walls.
 - Allowable loads have not been increased for wind, seismic, or other factors.
 - #8 screws are provided with each step bushing for attachment to the stud web.
 - Strengthening ribs are present in 3 5/8" and 6" sizes.
- ¹ For LRFD Design Strengths refer to ICC-ESR-2049.

Nomenclature

VertiTrack VTD is manufactured in 12 ft. lengths. VertiTrack is designated by type (VTD), followed by stud depth in inches multiplied by 100 and stud spacing.

Example: 6" deep stud, 16" on center
Designate: VertiTrack® VTD600-16



UL®-Classified Head of Wall Assemblies

HW-D-0003, HW-D-0024, HW-D-0025, HW-D-0036, HW-D-0042, HW-D-0043, HW-D-0044, HW-D-0045, HW-D-0046, HW-D-0047, HW-D-0048, HW-D-0049, HW-D-0054, HW-D-0062, HW-D-0063, HW-D-0066, HW-D-0067, HW-D-0068, HW-D-0069, HW-D-0071, HW-D-0072, HW-D-0073, HW-D-0076, HW-D-0077, HW-D-0082, HW-D-0083, HW-D-0084, HW-D-0085, HW-D-0087, HW-D-0089, HW-D-0091, HW-D-0102, HW-D-0106, HW-D-0152, HW-D-0154, HW-D-0160, HW-D-0162, HW-D-0167, HW-D-0184, HW-D-0185, HW-D-0186, HW-D-0190, HW-D-0193, HW-D-0209, HW-D-0218, HW-D-0246, HW-D-0256, HW-D-0259, HW-D-0263, HW-D-0271, HW-D-0272, HW-D-0275, HW-D-0277, HW-D-0278, HW-D-0280, HW-D-0293, HW-D-0299, HW-D-0310, HW-D-0313, HW-D-0321, HW-D-0322, HW-D-0324, HW-D-0341, HW-D-0342, HW-D-0353, HW-D-0356, HW-D-0357, HW-D-0358, HW-D-0363, HW-D-0365, HW-D-0368, HW-D-0370, HW-D-0371, HW-D-0401, HW-D-0404, HW-D-0420, HW-D-0421, HW-D-0453, HW-D-0455, HW-D-0460, HW-D-0461, HW-D-0462, HW-D-0463, HW-D-0466, HW-D-0468, HW-D-0470, HW-D-0475, HW-D-0477, HW-D-0483, HW-D-0491, HW-D-0526, HW-D-0527, HW-D-0532, HW-D-0545, HW-D-0639, HW-D-0642, HW-D-0644, HW-D-0645, HW-D-0646, HW-D-0687, HW-D-0689, HW-D-0695, HW-D-0696



VertiClip SLD600
 ICC-ESR-2049
www.icc-es.org



Meets criteria for New York MEA 326-06-M

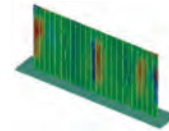

VertiClip SLD Series
 Blast and Seismic Design Data
www.steelnetwork.com

** For more information or to review a copy of each of these reports, please visit our website at <http://www.steelnetwork.com/Site/TechnicalData>

VertiTrack® VTX

Exterior Head of Wall

Material Composition

Clip Material: ASTM A1003/A1003M Structural Grade 50 (340) Type H, ST50H (ST340H): 50ksi (340MPa) minimum yield strength, 65ksi (450MPa) minimum tensile strength, 68mil minimum thickness (14 gauge, 0.0713" design thickness) with ASTM A653/A653M G90 (Z275) hot dipped galvanized coating.

Track Material: ASTM A1003/A1003M Structural Grade 33 (230) Type H, ST33H (ST230H): 33ksi (230MPa) minimum yield strength, 45ksi (310MPa) minimum tensile strength, 43mil minimum thickness (18 gauge, 0.0451" design thickness) with ASTM A653/A653M G60 (Z180) hot dipped galvanized coating.

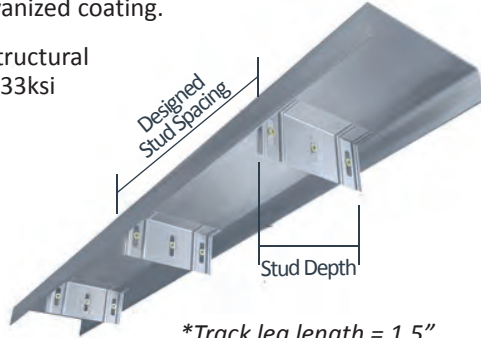

*Track leg length = 1.5".



US Patents #5,467,566 & #5,906,080

The attachment of VertiTrack to the primary structure may be made with PAFs, screw/bolt anchors or weld and is dependent upon the base material (steel or concrete) and the design configuration.

VertiTrack VTX Allowable (Unfactored) Loads¹

VertiTrack® VTX, Recommended Allowable Load (lbs): F1 & F2 (VertiClip® SL Loads)												
Stud		F1 Load Direction					F2 Load Direction					
Thickness Mils (ga)	Yield Strength (ksi)	VTX362	VTX400	VTX600		VTX800	VTX362	VTX400	VTX600		VTX800	
		w/2 #12 screws	w/2 #12 screws	w/2 #12 screws	w/3 #12 screws	w/2 #12 screws	w/2 #12 screws	w/2 #12 screws	w/2 #12 screws	w/3 #12 screws	w/2 #12 screws	w/3 #12 screws
33 (20)	33	190	190	190	285	190	377	377	377	565	377	565
33 (20)	50	248	199	275	367	275	544	544	544	817	544	817
43 (18)	33	248	199	248	367	248	561	561	561	841	561	841
43 (18)	50	248	199	359	367	359	790	810	810	1,215	810	1,215
54 (16)	33	248	199	312	367	312	789	789	789	1,183	789	1,183
54 (16)	50	248	199	367	367	362	790	1,136	1,139	1,680	1,139	1,709
68 (14)	50	248	199	367	367	362	790	1,136	1,610	1,680	1,610	1,870
97 (12)	50	248	199	367	367	362	790	1,136	1,680	1,680	1,698	1,870
Max Allowable Clip Load		248	199	367		362	790	1,136	1,680		1,870	

Notes:

- Allowable load tables incorporate eccentric loading of fasteners. Values with welded connection may increase.
- VertiTrack VTX is assembled with VertiClip SL pre-attached at 16" o.c. and 24" o.c.
- Loads are the same as VertiClip® SL.
- Fasten within 3/4" from the angle heel (centerline of the 1 1/2" leg) to minimize eccentric load transfer.
- VertiTrack VTX series is designed to support horizontal loads and should not be used in axial-load-bearing wall construction.
- Total vertical deflection of up to 1 1/2" (3/4" up and 3/4" down). Deflection requirements greater than 3/4" (up and down) are available. Custom spacing is also available.
- Allowable loads have not been increased for wind, seismic, or other factors.
- #12 screws are provided with each step bushing for attachment to the stud web.
- Strengthening ribs and guide holes are present in 3 5/8" and 6" sizes.

¹ For LRFD Design Strengths refer to ICC-ESR-2049.

Load Direction

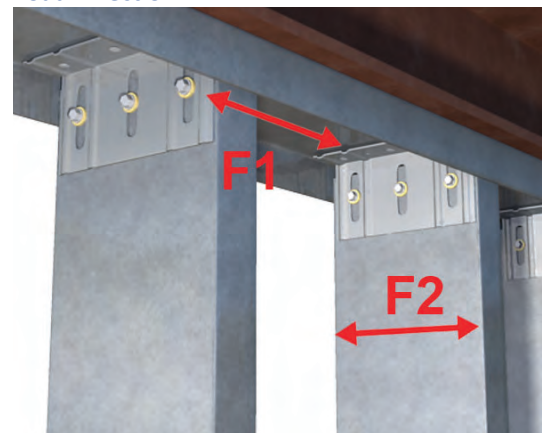

Nomenclature

VertiTrack VTX is manufactured in 12 ft. lengths. VertiTrack is designated by type (VTX), followed by stud depth in inches multiplied by 100 and stud spacing.

Example: 6" deep stud, 16" on center
Designate: VertiTrack® VTX600-16



UL®-Classified Head of Wall Assemblies

HW-D-0003, HW-D-0024, HW-D-0025, HW-D-0036, HW-D-0042, HW-D-0043, HW-D-0044, HW-D-0045, HW-D-0046, HW-D-0047, HW-D-0048, HW-D-0049, HW-D-0054, HW-D-0062, HW-D-0063, HW-D-0066, HW-D-0067, HW-D-0068, HW-D-0069, HW-D-0071, HW-D-0072, HW-D-0073, HW-D-0076, HW-D-0077, HW-D-0082, HW-D-0083, HW-D-0084, HW-D-0085, HW-D-0087, HW-D-0089, HW-D-0091, HW-D-0102, HW-D-0106, HW-D-0152, HW-D-0154, HW-D-0160, HW-D-0162, HW-D-0167, HW-D-0184, HW-D-0185, HW-D-0186, HW-D-0190, HW-D-0193, HW-D-0209, HW-D-0218, HW-D-0246, HW-D-0256, HW-D-0259, HW-D-0263, HW-D-0271, HW-D-0272, HW-D-0275, HW-D-0277, HW-D-0278, HW-D-0280, HW-D-0293, HW-D-0299, HW-D-0310, HW-D-0313, HW-D-0321, HW-D-0322, HW-D-0324, HW-D-0341, HW-D-0342, HW-D-0353, HW-D-0356, HW-D-0357, HW-D-0358, HW-D-0363, HW-D-0365, HW-D-0368, HW-D-0370, HW-D-0371, HW-D-0401, HW-D-0404, HW-D-0420, HW-D-0421, HW-D-0453, HW-D-0455, HW-D-0460, HW-D-0461, HW-D-0462, HW-D-0463, HW-D-0466, HW-D-0468, HW-D-0470, HW-D-0475, HW-D-0477, HW-D-0483, HW-D-0491, HW-D-0526, HW-D-0527, HW-D-0532, HW-D-0545, HW-D-0639, HW-D-0642, HW-D-0644, HW-D-0645, HW-D-0646, HW-D-0687, HW-D-0689, HW-D-0695, HW-D-0696



VertiClip SL362, SL600 & SL800
 ICC-ESR-2049
www.icc-es.org

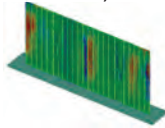

VertiClip SL Series
 Blast and Seismic Design Data
www.steelnetwork.com

* For more information or to review a copy of each of these reports, please visit our website at <http://www.steelnetwork.com/Site/TechnicalData>

VertiClip® SLD

Interior Head of Wall

The Steel Network, Inc. 
 www.steelnetwork.com
 1-888-474-4876

Material Composition

ASTM A1003/A1003M Structural Grade 50 (340) Type H, ST50H (ST340H): 50ksi (340MPa) minimum yield strength, 65ksi (450MPa) minimum tensile strength, 33mil minimum thickness (20 gauge, 0.0346" design thickness) with ASTM A653/A653M G60 (Z180) hot dipped galvanized coating.

The attachment of VertiClip to the primary structure may be made with PAFs, screw/bolt anchors or weld and is dependent upon the base material (steel or concrete) and the design configuration.

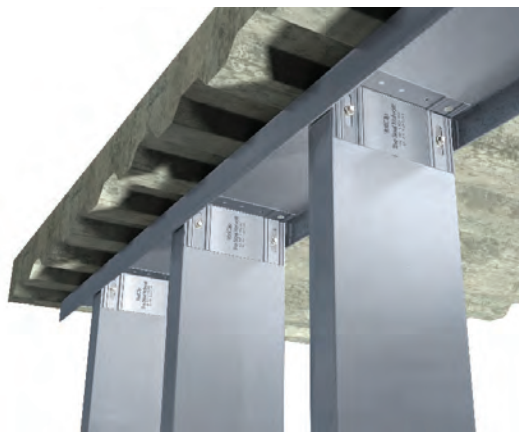
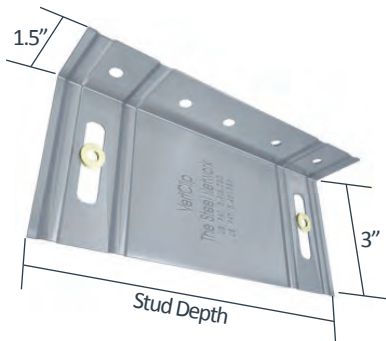

US Patents #5,467,566 & #5,906,080

VertiClip SLD Allowable (Unfactored) Loads¹

VertiClip® SLD, Recommended Allowable Load (lbs): F2						
Stud		SLD150	SLD250	SLD362/400	SLD600	SLD800
Thickness Mils (ga)	Yield Strength (ksi)	w/1 #8 screw	w/2 #8 screws	w/2 #8 screws	w/2 #8 screws	w/2 #8 screws
18 (25)	33	51	132	132	132	132
27 (22)	33	51	159	243	243	243
33 (20)	33	51	159	328	328	328
33 (20)	50	51	159	359	405	474
43 (18)	33	51	159	359	405	489
43 (18)	50	51	159	359	405	664
54 (16)	33	51	159	359	405	664
54 (16)	50	51	159	359	405	664
Maximum Allowable Clip Load		51	159	359	405	682

Load Direction

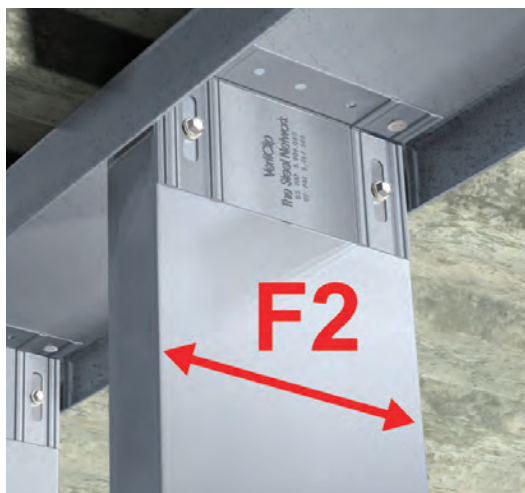

Notes:

- Fasten within 3/4" from the angle heel (centerline of the 1 1/2" leg) to minimize eccentric load transfer.
- Guide holes for attachment to structure are 0.141" for SLD362/400 and SLD600, and are not standard for other clip sizes.
- Total vertical deflection of up to 1 1/2" (3/4" up and 3/4" down). Deflection requirements greater than 3/4" (up and down) are available.
- VertiClip SLD series is designed to support horizontal loads and should not be used in axial-load-bearing wall construction.
- Allowable loads have not been increased for wind, seismic, or other factors.
- #8 screws are provided with each VertiClip SLD step bushing.
- Strengthening ribs are present in 3 5/8" and 6" sizes.

¹ For LRFD Design Strengths refer to ICC-ESR-2049.

Nomenclature

VertiClip SLD is designated by type (SLD), followed by stud depth in inches multiplied by 100.

Example: 6" stud
Designate: VertiClip® SLD600

Shaft Wall

VertiClip SLD may be used in shaft wall assemblies to provide a positive attachment at the top of wall. Sizes include VertiClip SLD150, SLD250, and SLD362 for 2.5", 4", and 6" shaft wall stud depths.



UL2079 & UL®-Classified
 WR Grace shaft wall
 assembly HW-D-0401.



When to Use VertiClip SLD and VertiClip SL

		When to Use VertiClip® SLD and VertiClip® SL																	
Wind Pressure		20 psf				25 psf				30 psf				40 psf					
Deflection Limit		L/360		L/600		L/360		L/600		L/360		L/600		L/360		L/600			
Stud Spacing		16" o.c.	24" o.c.	16" o.c.	24" o.c.	16" o.c.	24" o.c.	16" o.c.	24" o.c.	16" o.c.	24" o.c.	16" o.c.	24" o.c.	12" o.c.	16" o.c.	12" o.c.	16" o.c.		
362/400 Stud Depth	Wall Height (ft)	9'	SLD	SLD	SLD	SL	SLD	SLD	SLD	SL	SLD	SLD	SL	SL*	SLD	SLD	SL	SL	
		10'	SLD	SLD	SL	SL	SLD	SL	SL	SL*	SLD	SL	SL	SL*	SLD	SL	SL	SL*	
		12'	SL	SL*	SL*	SL*	SL	SL*	SL*	SL*	SL*	SL*	SL*	SL*	SL*	SL*	SL*	SL*	SL*
		15'	SL*	SL*	SL*	SL*	SL*	SL*	SL*	SL*	SL*	SL*	SL*	SL*	SL*	SL*	SL*	SL*	SL*
600 Stud Depth	Wall Height (ft)	9'	SLD	SLD	SLD	SLD	SLD	SLD	SLD	SLD	SLD	SLD	SLD	SLD	SLD	SLD	SLD	SLD	
		10'	SLD	SLD	SLD	SLD	SLD	SLD	SLD	SLD	SLD	SLD	SLD	SLD	SLD	SLD	SLD	SLD	
		12'	SLD	SLD	SLD	SLD	SLD	SLD	SLD	SLD	SLD	SLD	SLD	SLD	SL	SLD	SLD	SLD	SL
		15'	SLD	SLD	SL	SL	SLD	SL	SL	SL	SLD	SL	SL	SL*	SLD	SL	SL	SL*	SL*
		18'	SL	SL	SL	SL*	SL	SL	SL*	SL*	SL	SL*	SL*	SL*	SL*	SL	SL*	SL*	SL*
		21'	SL	SL*	SL*	SL*	SL*	SL*	SL*	SL*	SL*	SL*	SL*	SL*	SL*	SL*	SL*	SL*	SL*
800 Stud Depth	Wall Height (ft)	9'	SLD	SLD	SLD	SLD	SLD	SLD	SLD	SLD	SLD	SLD	SLD	SLD	SLD	SLD	SLD	SLD	
		10'	SLD	SLD	SLD	SLD	SLD	SLD	SLD	SLD	SLD	SLD	SLD	SLD	SLD	SLD	SLD	SLD	
		12'	SLD	SLD	SLD	SLD	SLD	SLD	SLD	SLD	SLD	SLD	SLD	SLD	SLD	SLD	SLD	SLD	
		15'	SLD	SLD	SLD	SLD	SLD	SLD	SLD	SLD	SLD	SL	SLD	SL	SLD	SLD	SLD	SL	
		18'	SLD	SLD	SLD	SL	SLD	SL	SL	SL	SLD	SL	SL	SL	SLD	SL	SL	SL	
		21'	SLD	SL	SL	SL*	SL	SL	SL	SL*	SL	SL	SL*	SL*	SL	SL	SL*	SL*	
		24'	SL	SL	SL*	SL*	SL	SL*	SL*	SL*	SL	SL*	SL*	SL*	SL*	SL	SL*	SL*	

Table Notes:

- SLD considered for use on 43 mil or thinner sections
- A load factor of 0.7 is used for deflection determination
- SL* means a single standard stud will not work. A wider flange wall stud (2" or 2.5" flange) is needed
- All connections can be made with use of 2 screws



UL2079 & UL®-Classified
WR Grace shaft wall
assembly HW-D-0401.



VertiClip SLD Series
Blast and Seismic Design Data
www.steelnetwork.com



VertiClip SLD600
ICC-ESR-2049
www.icc-es.org



Meets criteria for New
York MEA 326-06-M

** For more information or to review a copy of each of these reports, please visit our website at <http://www.steelnetwork.com/Site/TechnicalData>

VertiClip® SL

Exterior Head of Wall



Material Composition

ASTM A1003/A1003M Structural Grade 50 (340) Type H, ST50H (ST340H): 50ksi (340MPa) minimum yield strength, 65ksi (450MPa) minimum tensile strength, 68mil minimum thickness (14 gauge, 0.0713" design thickness) with ASTM A653/A653M G90 (Z275) hot dipped galvanized coating.

The attachment of VertiClip to the primary structure may be made with PAFs, screw/bolt anchors or weld and is dependent upon the base material (steel or concrete) and the design configuration.

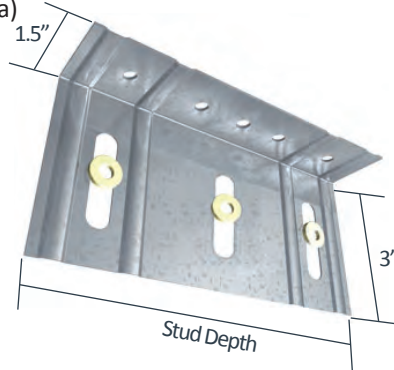

US Patents #5,467,566 & #5,906,080

VertiClip SL Allowable (Unfactored) Loads¹

VertiClip® SL, Recommended Allowable Load (lbs): F1										
Stud		SL362	SL400	SL600		SL800	SL1000		SL1200	
Thickness Mils (ga)	Yield Strength (ksi)	w/2 #12 screws	w/2 #12 screws	w/2 #12 screws	w/3 #12 screws	w/2 #12 screws	w/2 #12 screws	w/3 #12 screws	w/2 #12 screws	w/3 #12 screws
33 (20)	33	190	190	190	285	190	190	285	190	285
33 (20)	50	248	199	275	367	275	275	413	275	381
43 (18)	33	248	199	248	367	248	248	372	248	372
43 (18)	50	248	199	359	367	359	359	414	359	381
54 (16)	33	248	199	312	367	312	312	414	312	381
54 (16)	50	248	199	367	367	362	414	414	381	381
68 (14)	50	248	199	367	367	362	414	414	381	381
97 (12)	50	248	199	367	367	362	414	414	381	381
Maximum Allowable Clip Load		248	199	367		362	414		381	

VertiClip® SL, Recommended Allowable Load (lbs): F2											
Stud		SL362	SL400	SL600		SL800		SL1000		SL1200	
Thickness Mils (ga)	Yield Strength (ksi)	w/2 #12 screws	w/2 #12 screws	w/2 #12 screws	w/3 #12 screws	w/2 #12 screws	w/3 #12 screws	w/2 #12 screws	w/3 #12 screws	w/2 #12 screws	w/3 #12 screws
33 (20)	33	377	377	377	565	377	565	377	565	377	565
33 (20)	50	544	544	544	817	544	817	544	817	544	817
43 (18)	33	561	561	561	841	561	841	561	841	561	841
43 (18)	50	790	810	810	1,215	810	1,215	810	1,215	810	1,215
54 (16)	33	789	789	789	1,183	789	1,183	789	1,183	789	1,183
54 (16)	50	790	1,136	1,139	1,680	1,139	1,709	1,139	1,577	1,139	1,709
68 (14)	50	790	1,136	1,610	1,680	1,610	1,870	1,577	1,577	1,610	1,791
97 (12)	50	790	1,136	1,680	1,680	1,698	1,870	1,577	1,577	1,698	1,791
Maximum Allowable Clip Load		790	1,136	1,680		1,870	1,870	1,577		1,791	

Notes:

- Allowable load tables incorporate eccentric loading of fasteners. Values with welded connection may increase.
- Fasten within 3/4" from the angle heel (centerline of the 1 1/2" leg) to minimize eccentric load transfer.
- Guide holes for attachment to structure are 0.141" for SL362 & SL600 Guideholes are not standard in other clip sizes.
- VertiClip SL series is designed to support horizontal loads and should not be used in axial-load-bearing wall construction.
- Total vertical deflection of up to 1 1/2" (3/4" up and 3/4" down). Deflection requirements greater than 3/8" (up and down) are available.
- Allowable loads have not been increased for wind, seismic, or other factors.
- #12 screws are provided with each step bushing.
- Strengthening ribs and guide holes are present in 3 5/8" and 6" sizes.

¹ For LRFD Design Strengths refer to ICC-ESR-2049.

Load Direction

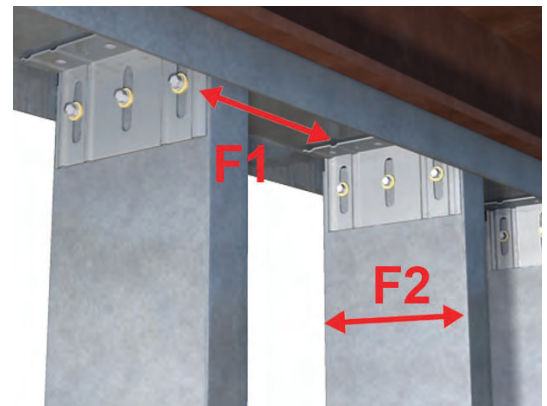

Nomenclature

VertiClip SL is designated by type (SL), followed by stud depth in inches multiplied by 100.

Example: 6" stud

Designate: VertiClip® SL600



VertiClip SL362, SL600 & SL800
ICC-ESR-2049
www.icc-es.org

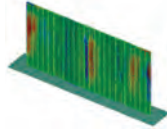

VertiClip SL Series
Blast and Seismic Design Data
www.steelnetwork.com

** For more information or to review a copy of each of these reports, please visit our website at <http://www.steelnetwork.com/Site/TechnicalData>

VertiClip® SLD w/ 3" slots

Interior Head of Wall

The Steel Network, Inc. 
 www.steelnetwork.com
 1-888-474-4876

Material Composition

ASTM A1003/A1003M Structural Grade 50 (340) Type H, ST50H (ST340H): 50ksi (340MPa) minimum yield strength, 65ksi (450MPa) minimum tensile strength, 33mil minimum thickness (20 gauge, 0.0346" design thickness) with ASTM A653/A653M G60 (Z180) hot dipped galvanized coating.

The attachment of VertiClip to the primary structure may be made with a PAF or weld and is dependent upon the base material (steel or concrete) and the design configuration.

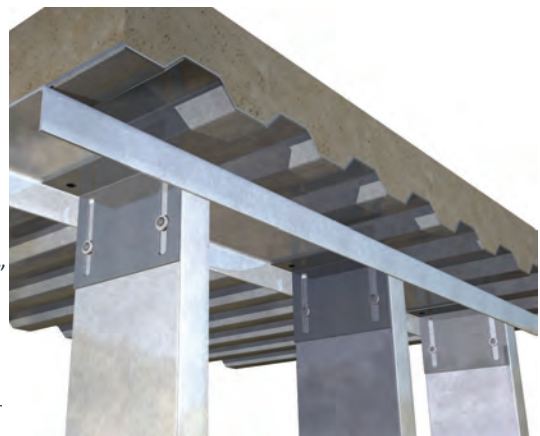
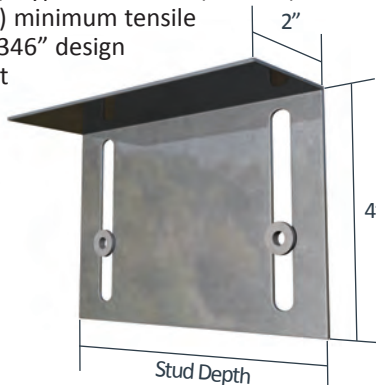

US Patents #5,467,566 & #5,906,080

VertiClip SLD w/ 3" Deflection Allowable (Unfactored) Loads¹

VertiClip® SLD w/ 3" Deflection, Recommended Allowable Load (lbs): F2				
Stud		SLD362, s3lg,b2d	SLD600, s3lg,b2d	SLD800, s3lg,b2d
Thickness Mils (ga)	Yield Strength (ksi)	w/ 2 #8 Screws	w/ 2 #8 Screws	w/ 3 #8 Screws
18 (25)	33	132	132	132
27 (22)	33	185	242	243
30 (20 - Drywall)	33	185	242	251
33 (20 - Structural)	33	185	242	251
33 (20)	50	185	242	251
43 (18)	33	185	242	251
43 (18)	50	185	242	251
54 (16)	33	185	242	251
54 (16)	50	185	242	251
Maximum Allowable Clip Load		185	242	251

Notes:

- Meets criteria for IBC 2009, 2012. Factor of Safety calculated according to ICC-ES AC208 and section F1 of AISI S100-07
- Fasten within 3/4" from the angle heel to minimize eccentric load transfer.
- VertiClip SLD series is designed to support horizontal loads and should not be used in axial-load-bearing wall construction.
- Total vertical deflection of up to 3" (1 1/2" up and 1 1/2" down).
- The standard bushing placement is 2" from the top of the slot and allows the structure to settle 1/2" prior to typical service.
- Allowable loads have not been increased for wind, seismic, or other factors.
- #8 screws are provided with each pre-installed step bushing.
- Tests performed with bushings centered in the 3" slots.

Load Direction

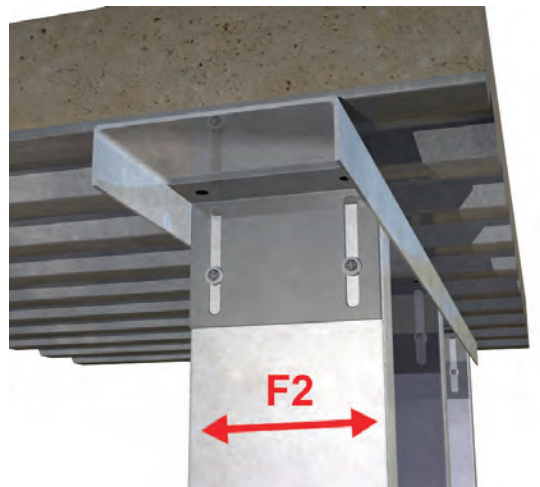

Nomenclature

VertiClip SLD with 3" deflection is designated by type (SLD), followed by stud depth in inches multiplied by 100, slot length (s "length in inches" lg), and bushing placement (b "distance from top slot in inches" d).

Example: 6" deep stud, 3" slot, bushings 2" down from top of slot

Designate: VertiClip® SLD600,s3lg,b2d

VertiClip® SL w/ 3" slots

Exterior Head of Wall

Material Composition

ASTM A1003/A1003M Structural Grade 50 (340) Type H, ST50H (ST340H): 50ksi (340MPa) minimum yield strength, 65ksi (450MPa) minimum tensile strength, 68mil minimum thickness (14 gauge, 0.0713" design thickness) with ASTM A653/A653M G90 (Z275) hot dipped galvanized coating.

The attachment of VertiClip to the primary structure may be made with a PAF or weld and is dependent upon the base material (steel or concrete) and the design configuration.

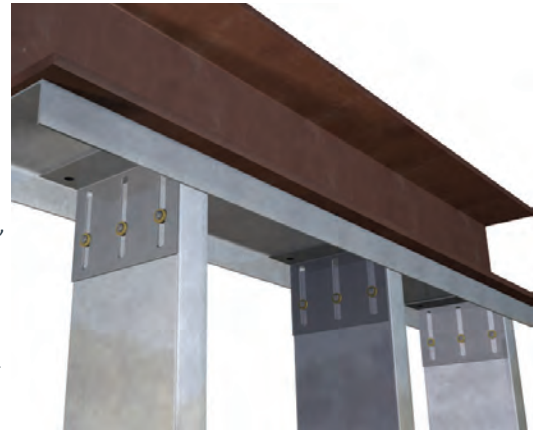
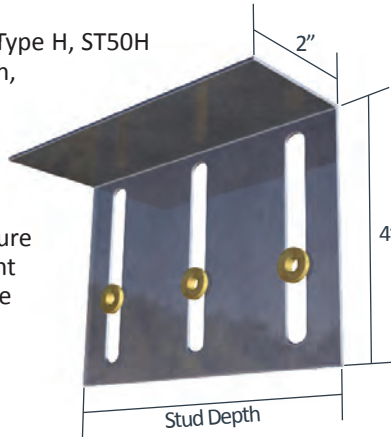

US Patents #5,467,566 & #5,906,080

VertiClip SL w/ 3" Deflection Allowable (Unfactored) Loads¹

VertiClip® SL w/ 3" Deflection, Recommended Allowable Load (lbs): F1 & F2								
Stud		F1 Load Direction		F2 Load Direction				
		SL600, s3lg,b2d		SL362, s3lg,b2d	SL600, s3lg,b2d		SL800, s3lg,b2d	
Thickness Mils (ga)	Yield Strength (ksi)	w/2 #12 Screws	w/3 #12 Screws	w/2 #12 Screws	w/2 #12 Screws	w/3 #12 Screws	w/2 #12 Screws	w/3 #12 Screws
33 (20)	33	191	277	377	377	565	377	565
33 (20)	50	275	277	544	544	817	544	817
43 (18)	33	248	277	561	561	841	561	841
43 (18)	50	277	277	617	810	1,215	810	1,215
54 (16)	33	277	277	617	789	1,183	789	1,183
54 (16)	50	277	277	617	1,139	1,571	1,139	1,709
68 (14)	50	277	277	617	1,571	1,571	1,610	1,915
97 (12)	50	277	277	617	1,571	1,571	1,698	1,915
Maximum Allowable Clip Load		277		617	1,571		1,915	

Notes:

- Meets criteria for IBC 2009, 2012. Factor of Safety calculated according to ICC-ES AC261 and section F1 of AISI S100-07
- Fasten within 3/8" from the angle heel to minimize eccentric load transfer.
- VertiClip SL series is designed to support horizontal loads and should not be used in axial-load-bearing wall construction.
- Total vertical deflection of up to 3" (1 1/2" up and 1 1/2" down).
- The standard bushing placement is 2" from the top of the slot and allows the structure to settle 1/2" prior to typical service.
- Allowable loads have not been increased for wind, seismic, or other factors.
- #12 screws are provided with each pre-installed step bushing.
- Tests performed with bushings centered in the 3" slots.

Load Direction

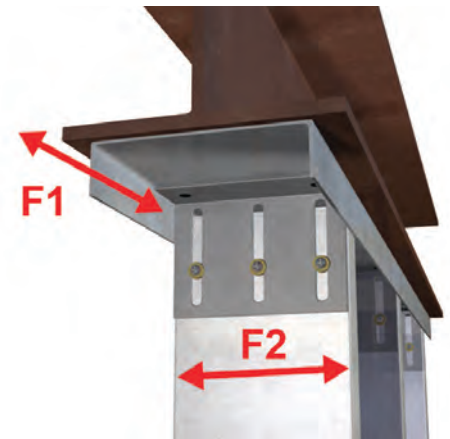

Nomenclature

VertiClip SL with 3" deflection is designated by type (SL), followed by stud depth in inches multiplied by 100, slot length (s "length in inches" lg), and bushing placement (b "distance from top slot in inches" d).

Example: 6" deep stud, 3" slot, bushings 2" down from top of slot

Designate: VertiClip® SL600,s3lg,b2d

VertiClip® SLS

Bypass Structure



Material Composition

ASTM A1003/A1003M Structural Grade 50 (340) Type H, ST50H (ST340H): 50ksi (340 MPa) minimum yield strength, 65ksi (450 MPa) minimum tensile strength, 68mil minimum thickness (14 gauge, 0.0713" design thickness) with ASTM A653/A653M G90 (Z275) hot dipped galvanized coating.

The attachment of VertiClip to the primary structure may be made with PAFs, screw/bolt anchors or weld and is dependent upon the base material (steel or concrete) and the design configuration.

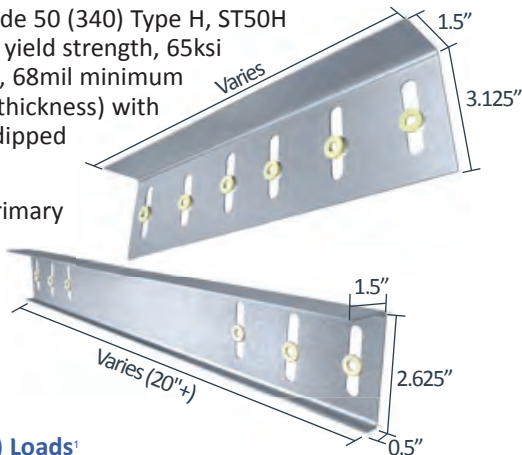

US Patents #5,467,566 & #5,906,080

VertiClip SLS Allowable (Unfactored) Loads¹

VertiClip® SLS, Recommended Allowable Load (lbs): F1							
Stud		SLS362/400-9, -12	SLS600-12	SLS600-15, -18, -20	SLS600-24	SLS800-12	SLS800-15, 18, -20
Thickness Mils (ga)	Yield Strength (ksi)	w/2 #12 screws	w/2 or 3 #12 screws	w/2 or 3 #12 screws	w/2 or 3 #12 screws	w/2 or 3 #12 screws	w/2 or 3 #12 screws
33 (20)	33	95	95	95	95	95	95
33 (20)	50	124	138	130	100	138	125
43 (18)	33	124	124	124	100	124	124
43 (18)	50	124	164	130	100	141	125
54 (16)	33	124	156	130	100	141	125
54 (16)	50	124	164	130	100	141	125
68 (14)	50	124	164	130	100	141	125
97 (12)	50	124	164	130	100	141	125
Max Allowable Clip Load		124	164	130	100	141	125

VertiClip® SLS, Recommended Allowable Load (lbs): F2										
Stud		SLS362/400-9, -12	SLS600-12		SLS600-15, -18, -20		SLS600-24		SLS800-12, -15, 18, -20	
Thickness Mils (ga)	Yield Strength (ksi)	w/2 #12 screws	w/2 #12 screws	w/3 #12 screws	w/2 #12 screws	w/3 #12 screws	w/2 #12 screws	w/3 #12 screws	w/2 #12 screws	w/3 #12 screws
33 (20)	33	377	377	565	377	565	377	565	377	565
33 (20)	50	544	544	817	544	817	544	817	544	817
43 (18)	33	561	561	841	561	841	561	841	561	841
43 (18)	50	810	810	1,215	810	1,215	810	1,215	810	1,215
54 (16)	33	789	789	1,183	789	1,183	789	1,183	789	1,183
54 (16)	50	1,139	1,139	1,709	1,139	1,709	1,139	1,709	1,139	1,709
68 (14)	50	1,245	1,610	2,070	1,610	2,122	1,610	1,896	1,610	1,816
97 (12)	50	1,245	1,698	2,070	1,698	2,122	1,698	1,896	1,698	1,816
Max Allowable Clip Load		1,245	2,070		2,122		1,896		1,816	

Notes:

- VertiClip SLS series is designed to support horizontal loads and should not be used in axial-load-bearing wall construction.
- Allowable loads have not been increased for wind, seismic, or other factors.
- #12 screws are provided with each Step Bushing.
- Return lip added for clips longer than 20".
- Allowable load tables incorporate eccentric loading of fasteners. Values with welded connection may increase.
- Fasten within 3/4" from the angle heel (centerline of the 1 1/2" leg) to minimize eccentric load transfer.
- Minimum 3" of SLS required for attachment to structure to steel and 5.5" min. with concrete.
- Total vertical deflection of up to 1 1/2" (3/4" up and 3/4" down). Deflection requirements greater than 3/4" up and down are available.

¹ For LRFD Design Strengths refer to ICC-ESR-2049.

Load Direction



Nomenclature

VertiClip SLS is designated by stud depth and clip length required. Clip length includes a minimum of 3" for steel (5.5" for concrete) of clip material for attachment to structure added to stud depth, plus the distance of the stud from the structure.

Example: 6" stud, 6" tolerance, 3" to structure

Designate: VertiClip® SLS600-15

* Use of strengthening ribs and return bends varies with each clip.

Example Details

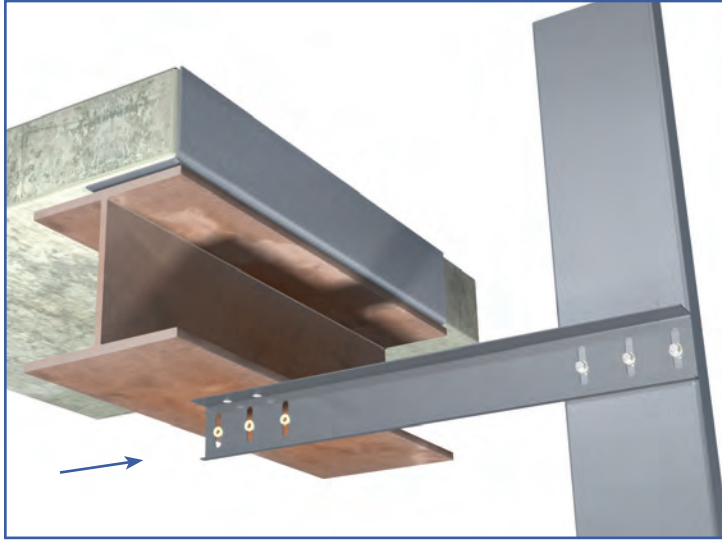

Return lip added for clips longer than 20" (up to 36")

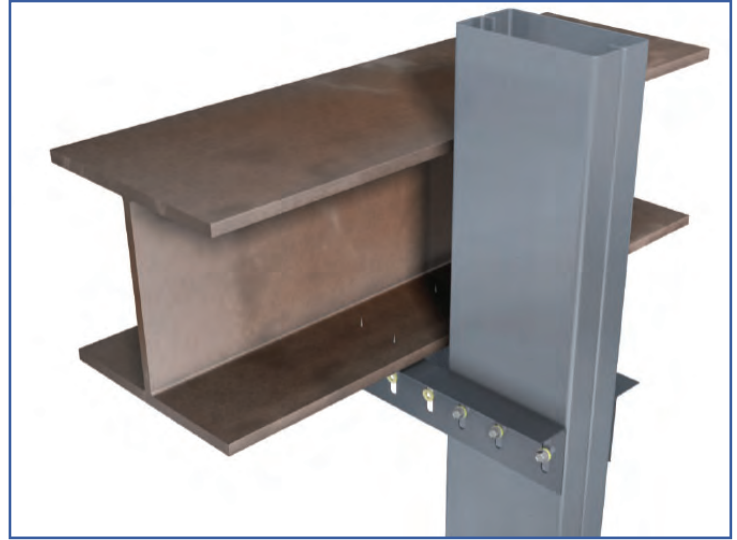

VertiClip SLS at jamb (studs facing each other).



VertiClip SLS600-12
ICC-ESR-2049
www.icc-es.org

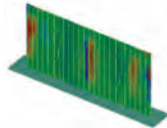

VertiClip SLS Series
Blast and Seismic Design Data
www.steelnetwork.com

** For more information or to review a copy of each of these reports, please visit our website at <http://www.steelnetwork.com/Site/TechnicalData>

VertiClip® SLB

Bypass Slab

Material Composition

ASTM A1003/A1003M Structural Grade 50 (340) Type H, ST50H (ST340H): 50ksi (340MPa) minimum yield strength, 65ksi (450MPa) minimum tensile strength, 68mil minimum thickness (14 gauge, 0.0713" design thickness) with ASTM A653/A653M G90 (Z275) hot dipped galvanized coating.

The attachment of VertiClip to the primary structure may be made with PAFs, screw/bolt anchors or weld and is dependent upon the base material (steel or concrete) and the design configuration.

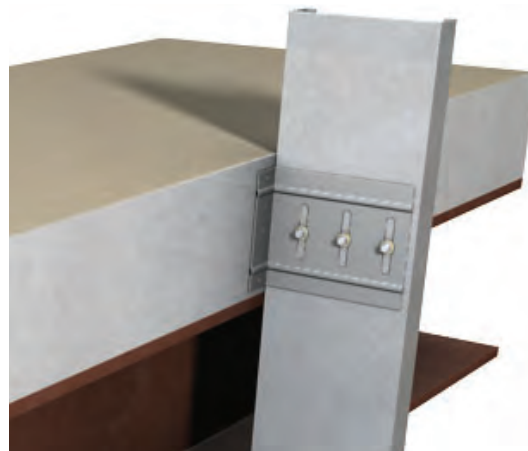
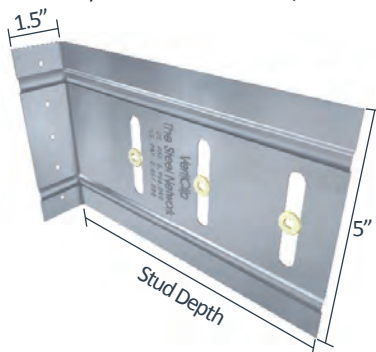

US Patents #5,467,566 & #5,906,080

VertiClip SLB Allowable (Unfactored) Loads¹

VertiClip® SLB, Recommended Allowable Load (lbs): F1 & F2								
Stud		F1 Load Direction			F2 Load Direction			
		SLB250 & SLB362/400	SLB600	SLB800	SLB250, SLB362/400*, SLB600 & SLB800	SLBxxx-10, SLBxxx-12, SLB1000 & SLB1200		
Thickness Mils (ga)	Yield Strength (ksi)	w/2 #12 Screws	w/2-3 #12 Screws	w/2-3 #12 Screws	w/2 #12 Screws	w/3 #12 Screws	w/2 #12 Screws	w/3 #12 Screws
33 (20)	33	95	95	95	377	565	376	564
33 (20)	50	138	138	107	544	817	544	817
43 (18)	33	124	124	107	561	841	560	840
43 (18)	50	179	179	107	810	1,215	810	933
54 (16)	33	156	156	107	789	1,183	788	933
54 (16)	50	225	225	107	1,139	1,567	933	933
68 (14)	50	227	227	107	1,567	1,567	933	933
97 (12)	50	227	227	107	1,567	1,567	933	933
Max Allowable Clip Load		227	227	107	1,567		933	

* SLB362/400 only allows 2 screws

Notes:

- Allowable load tables incorporate eccentric loading of fasteners. Values with welded connection may increase.
- Fasten within 3/4" from the angle heel (centerline of the 1 1/2" leg) to minimize eccentric load transfer.
- Fasteners attaching clip to structure should be installed symmetrically around the center line of the clip. The allowable load of the clip may be reduced if fasteners are not installed symmetrically.
- Guide holes in the 1 1/2" leg measure 0.172" in diameter for SLB362, 0.141" in diameter for SLB600 and SLB800.
- Total vertical deflection of up to 2" (1" up and 1" down). Deflection requirements greater than 1" up and down are available.
- VertiClip SLB series is designed to support horizontal loads and should not be used in axial-load-bearing wall construction.
- Allowable loads have not been increased for wind, seismic, or other factors.
- #12 screws are provided with each step bushing. Load requirements don't always justify use of a third screw.
- Three slots are standard in 6" and higher web depths to accommodate construction tolerances. Use of a 3rd screw and bushing is dependent upon load configuration. 250 and 362/400 sizes have only 2 slots and 2 screws.
- Use of strengthening ribs and return bends varies with each clip.

¹ For LRFD Design Strengths refer to ICC-ESR-2049.

Load Direction



Nomenclature

VertiClip SLB is designated by multiplying stud depth by 100.

Example: 6" stud.

Designate: VertiClip® SLB600

* Use of strengthening ribs and return bends varies with each clip.

** The VertiClip SLB600-10 and 600-12 accommodate an even greater construction tolerance of studs from structure.

The VertiClip SLB600-10 is 10" in depth and the VertiClip SLB600-12 is 12" in depth with slot spacings designed for a 6" stud

Example Details

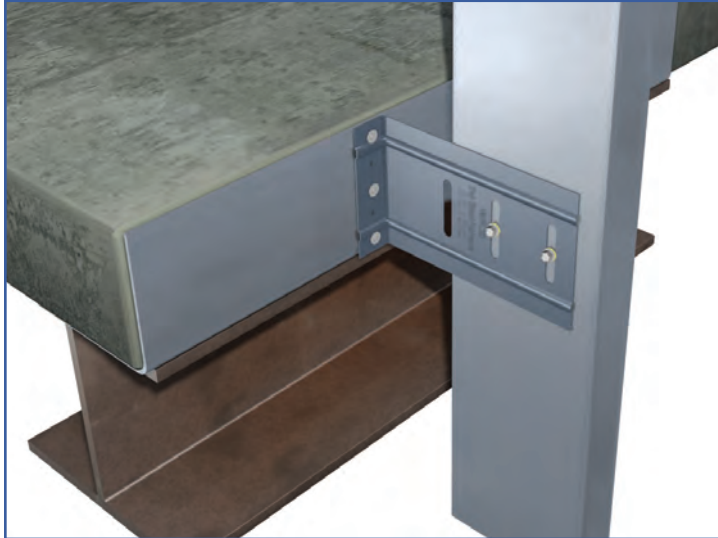

Standard offset of stud from the heel of the clip should not exceed 1.0". Step Bushings and Screws may be installed in the middle and outer slots of SLB600 or 800 to accommodate greater building tolerances. Note that this may affect the F1 and F2 allowable load capacity and may require a row of bridging at a maximum distance of 12" of the connection to resist stud torsional effects. Call TSN Tech Support for test data and recommendations.

The VertiClip SLB600-10 and 600-12 accommodate an even greater construction tolerance of studs from structure and are now standard products. The VertiClip SLB600-10 is 10" in depth with slot spacing designed for a 6" stud, and the VertiClip SLB600-12 is 12" in depth with slot spacing designed for a 6" stud.



VertiClip SLB600
ICC-ESR-2049
www.icc-es.org

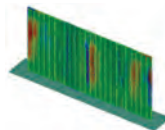

VertiClip SLB Series
Blast and Seismic Design Data
www.steelnetwork.com

** For more information or to review a copy of each of these reports, please visit our website at <http://www.steelnetwork.com/Site/TechnicalData>

VertiClip® SLB-HD

Bypass Slab for Seismic Conditions

The Steel Network, Inc. 
 www.steelnetwork.com
 1-888-474-4876

Material Composition

ASTM A1003/A1003M Structural Grade 50 (340) Type H, ST50H (ST340H): 50ksi (340 MPa) minimum yield strength, 65ksi minimum tensile strength, 68mil minimum thickness (14 gauge, 0.0713" design thickness) with ASTM A653/653M G90 (Z275) hot dipped galvanized coating.

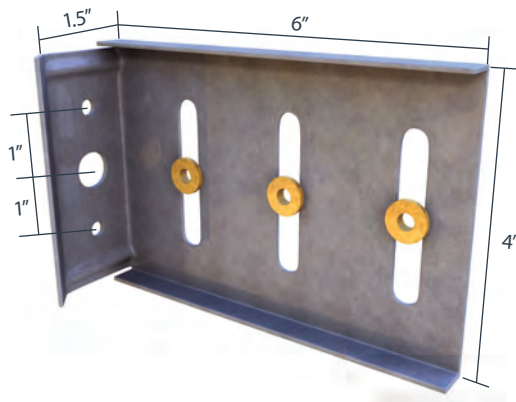

US Patent # 5,906,080

VertiClip SLB-HD Allowable (Unfactored) Loads¹

VertiClip® SLB-HD, Recommended Allowable Load (lbs): F1 & F2						
Stud		F1 Allowable (ASD) Loads	F2 Allowable (ASD) Loads with Two ¼" Concrete Fasteners			F2 Allowable (ASD) Loads with One ½" Concrete Anchor
Thickness Mils (ga)	Yield Strength (ksi)	w/2-3 #12 Screws	w/2* #12 Screws	w/3 #12 Screws	w/2* #12 Screws	w/3 #12 Screws
33 (20)	33	95	376	564	376	564
43 (18)	33	124	560	840	560	840
54 (16)	33	156	788	1,182	788	1,003
54 (16)	50	225	1,140	1,187	1,003	1,003
68 (14)	50	234	1,187	1,187	1,003	1,003
97 (12)	50	234	1,187	1,187	1,003	1,003
Maximum Allowable Clip Load		234	1,187		1,003	

Notes:

- Fasten within ¾" from the angle heel (centerline of the 1 ½" leg) to minimize eccentric load transfer.
- Guide holes for structure connection are 0.375" diameter for (2) ¼" concrete screws, and 0.625" diameter for (1) ½" concrete anchor.
- VertiClip SLB-HD allows up to 2" of vertical deflection (1" up and 1" down).
- VertiClip SLB600-HD is designed to support horizontal loads and should not be used in axial-load-bearing wall construction.
- Allowable loads have not been increased for wind, seismic, or other factors.
- (3) bushings are provided with each clip. Based on the application and evaluation by the design professional, two may be sufficient. If only the outer two slots are used to accommodate greater building tolerances, allowable loads may be reduced.
- Loads listed reflect force in a single direction. When multiple loads act on the connection, it is the responsibility of the designer to check the interaction of the forces.
- The recommended allowable load is for the clip and attachment to the stud only. The design professional must design attachment to the primary structure.

¹ For LRFD Design Strengths refer to ICC-ESR-2049.

* First and third bushings installed

Load Direction

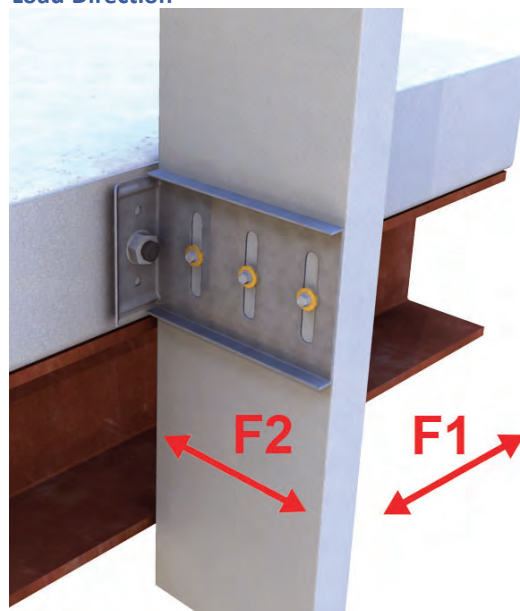

Nomenclature

VertiClip SLB-HD is designed to be used with 6" studs and is designated *VertiClip® SLB600-HD*

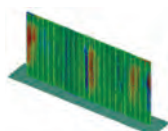

VertiClip SLB-HD Series
 Blast and Seismic Design Data
 www.steelnetwork.com

** For more information or to review a copy of this report, please visit our website at <http://www.steelnetwork.com/Site/TechnicalData>

VertiClip® SLF

Bypass Top of Slab

Material Composition

ASTM A1003/A1003M Structural Grade 50 (340) Type H, ST50H (ST340H): 50ksi (340 MPa) minimum yield strength, 65ksi (450 MPa) minimum tensile strength, 68mil minimum thickness (14 gauge, 0.0713" design thickness) with ASTM A653/653M G90 (Z275) hot dipped galvanized coating.

The attachment of VertiClip to the primary structure may be made with PAFs, screw/bolt anchors or weld and is dependent upon the base material (steel or concrete) and the design configuration.

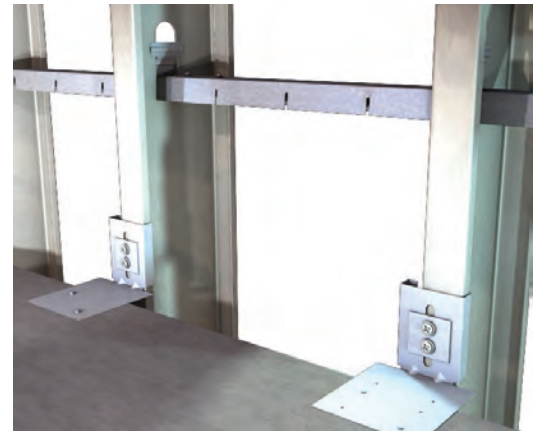
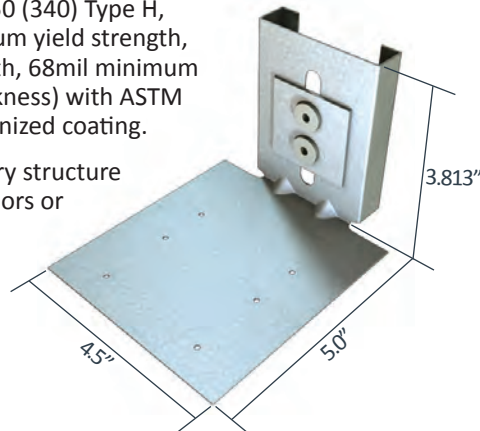

US Patent # 8,511,032

VertiClip SLF Allowable (Unfactored) Loads¹

VertiClip® SLF, Recommended Allowable Load (lbs): F2		
Stud		w/2 #12 screws
Thickness Mils (ga)	Yield Strength (ksi)	
43 (18)	33	281
43 (18)	50	326
54 (16)	50	465
68 (14) and up	50	632
Maximum Allowable Clip Load		632

Notes:

- Stud web crippling should be checked. Use 3½" bearing length and "Interior Reaction – one Flange", Condition 2, for the web crippling calculations except at end of stud use "End Reaction – one Flange", Condition 1.
 - Align rows of wall bridging so that one row of bridging falls within 12" from VertiClip SLF **OR** use one flat strap bracing on outer flange of studs to resist torsional effects.
 - Allowable loads have not been increased for wind, seismic, or other factors.
 - #12 screws are provided with each Step Bushing.
 - VertiClip SLF allows up to 1½" of vertical deflection (¾" up and ¾" down)
- ¹ For LRFD Design Strengths contact TSN technical services.

Load Direction



Nomenclature

VertiClip SLF is available in one size for all stud depths with 1 5/8" flanges and is designated VertiClip® SLF162

* VertiClip SLF for use with 2" stud flanges can be made as a custom part.

Example Details

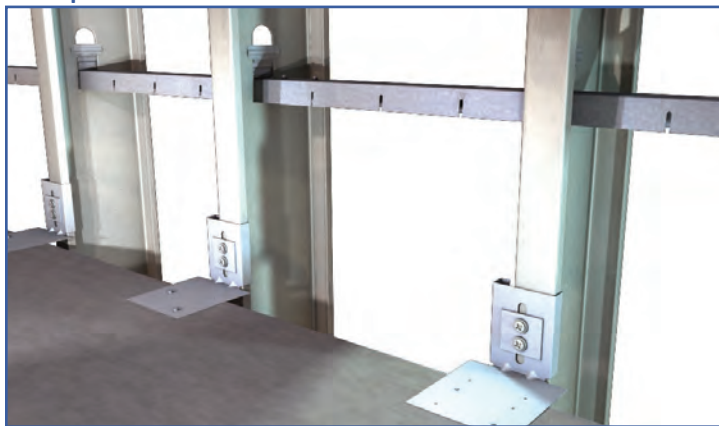

VertiClip SLF used with TSN's BridgeBar® & BridgeClip® installed within 12" from the clip.

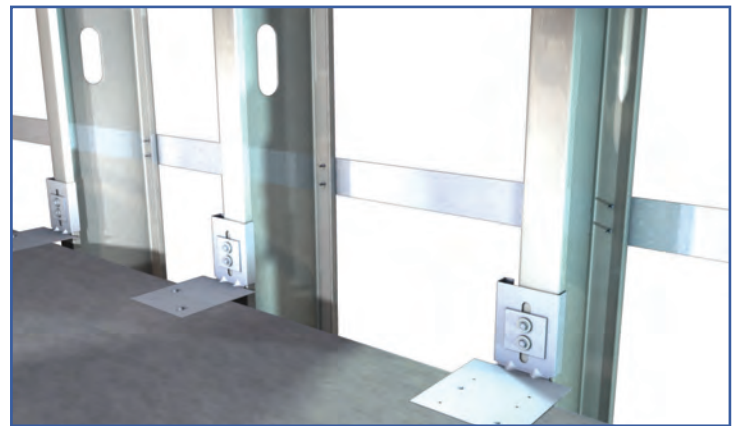

VertiClip SLF used with one flat strap bracing on the outer flange of studs to resist torsional effects.

VertiClip® SLT

Structure/Slab Bypass

Material Composition

ASTM A1003/A1003M Structural Grade 50 (340) Type H, ST50H (ST340H): 50ksi (340MPa) minimum yield strength, 65ksi (450MPa) minimum tensile strength, 97mil minimum thickness (12 gauge, 0.1017" design thickness) with ASTM A653/A653M G90 (Z275) hot dipped galvanized coating.

The attachment of VertiClip to the primary structure may be made with PAF, screw/bolt anchors, or weld and is dependent upon the base material (steel or concrete) and the design configuration.

VertiClip® SLT(S)

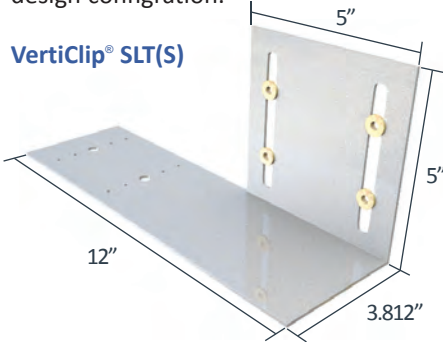

VertiClip® SLT(L)

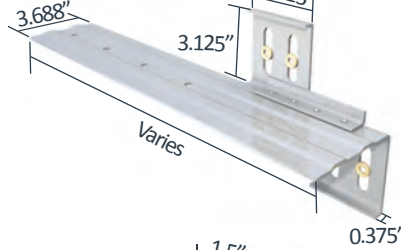

VertiClip® SLT

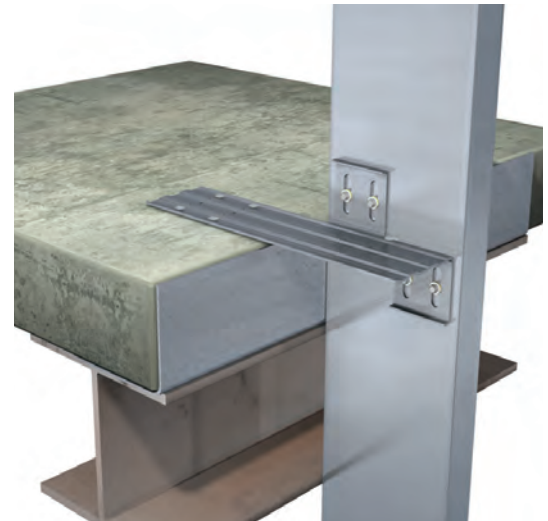
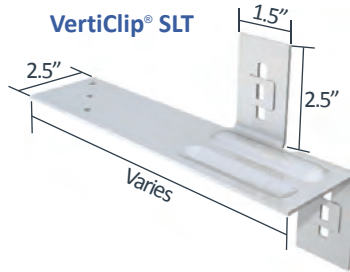

US Patents #5,467,566 & #5,906,080

VertiClip SLT Allowable (Unfactored) Loads*

VertiClip® SLT & SLT(L), Recommended Allowable Load (lbs): F1 & F2											
Stud		F1 Load Direction			F2 Load Direction						
		SLT9.5	SLT(L)12, SLT(L)15 & SLT(L)18	SLT-9.5	SLT(L)12		SLT(L)15		SLT(L)18		
Thickness Mils (ga)	Yield Strength (ksi)	w/2 #12 screws	w/2 #12 screws	w/4 #12 screws	w/2 #12 screws	w/2 #12 screws	w/4 #12 screws	w/2 #12 screws	w/4 #12 screws	w/2 #12 screws	w/4 #12 screws
33 (20)	33	190	190	380	376	376	754	376	744	376	700
33 (20)	50	275	275	452	510	544	903	544	744	544	700
43 (18)	33	248	248	452	510	560	903	560	744	560	700
43 (18)	50	341	359	452	510	810	903	744	744	700	700
54 (16)	33	312	312	452	510	789	903	744	744	700	700
54 (16)	50	341	450	452	510	903	903	744	744	700	700
68 (14)	50	341	452	452	510	903	903	744	744	700	700
97 (12)	50	341	452	452	510	903	903	744	744	700	700
Max Allowable Clip Load		341	452	510	903	744	700	744	700	700	700

VertiClip® SLT(S), Recommended Allowable Load (lbs): F1 & F2					
Stud		F1 Load Direction		F2 Load Direction	
		Back Fasteners	Front Fasteners	Back Fasteners	Front Fasteners
Thickness Mils (ga)	Yield Strength (ksi)	w/4 #12 screws	w/4 #12 screws	w/4 #12 screws	w/4 #12 screws
33 (20)	33	191	191	381	381
33 (20)	50	275	275	550	550
43 (18)	33	248	248	566	566
43 (18)	50	330	282	818	818
54 (16)	33	330	282	796	796
54 (16)	50	330	282	890	917
68 (14)	50	330	282	890	917
97 (12)	50	330	282	890	917
Max Allowable Clip Load		330	282	890	917

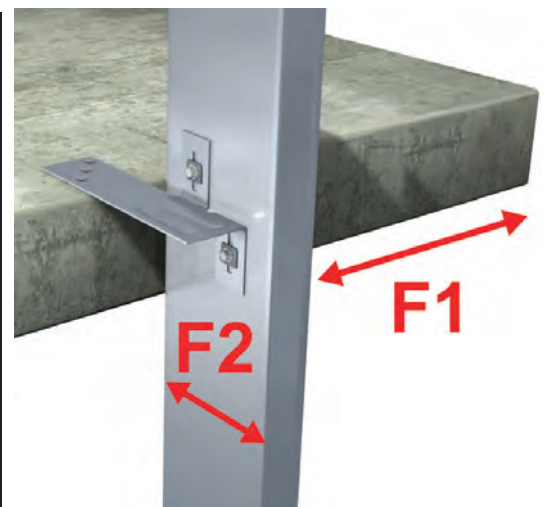

****Important notes for VertiClip SLT Allowable Load tables continued on next page.**

Table Notes:

- VertiClip SLT series is designed to support horizontal loads and must not be used in axial-load-bearing wall construction.
 - Allowable loads have not been increased for wind, seismic, or other factors.
 - #12 screws are provided with each Step Bushing.
 - VertiClip SLT & SLT(S) allow up to 2" of vertical deflection (1" up and 1" down).
 - VertiClip SLT(L) allows up to 1.875" of vertical deflection (0.938" up and 0.938" down)
 - VertiClip SLT(S) Recommended Allowable Loads are based on 4 #12 screws at the stud attachment and either front or rear fastener attachment at the structure respectfully.
 - Torsional effects are considered on screw group for F2 allowable loads. All torsion attributed to screws, none to the clip connection to structure.
 - VertiClip SLT is recommended to have for steel attachment a ½" minimum edge distance from fasteners and for concrete attachment a 2 ¼" minimum edge distance from fasteners.
- † For LRFD Design Strengths refer to ICC-ESR-2049.

Nomenclature

VertiClip SLT is available in a length of 9 ½". VertiClip SLT(S) is available in a length of 12". VertiClip SLT(L) is available in lengths of 12", 15", and 18". Determine length by adding stud + offset + 3" for steel (5.5" for concrete) and selecting the next largest size.

Example: 6" stud, 4" offset + 3"
Designate: VertiClip® SLT(L)15

Example Details



VertiClip SLT attached to the underside of wide flange beam.

VertiClip SLT(S) Fastener Patterns

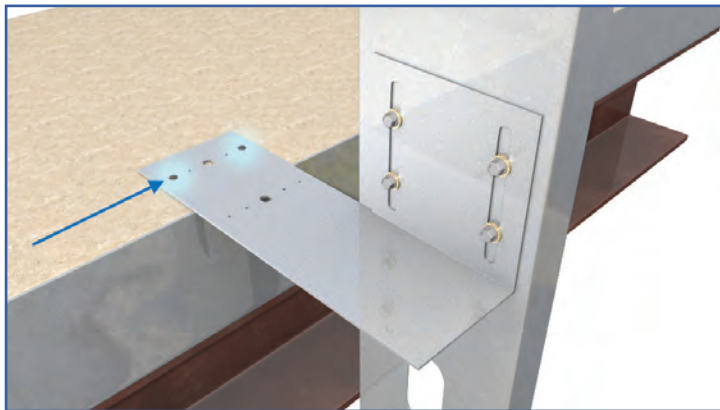

Back Fasteners Attachment to Structure

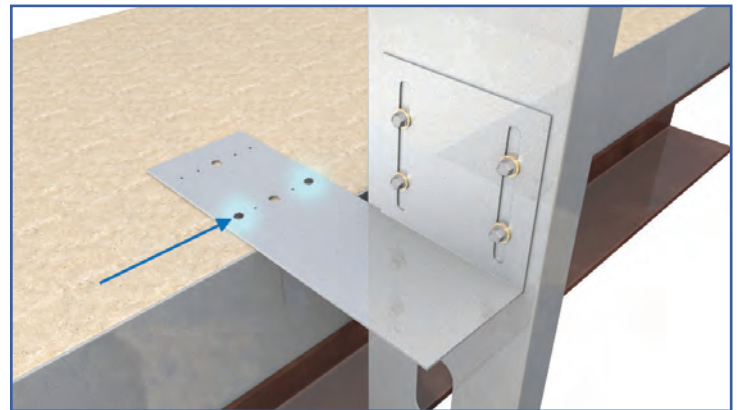

Front Fasteners Attachment to Structure



VertiClip SLT 9.5 & SLT(L)-18
 ICC-ESR-2049
 www.icc-es.org

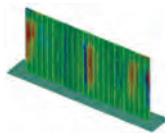

VertiClip SLT Series
 Blast and Seismic Design Data
 www.steelnetwork.com

** For more information or to review a copy of each of these reports, please visit our website at <http://www.steelnetwork.com/Site/TechnicalData>

MasterClip® VLB

Bypass Slab

The Steel Network, Inc.
www.steelnetwork.com
1-888-474-4876



Material Composition

ASTM A1003/A1003M Structural Grade 50 (340) Type H, ST50H (ST340H): 50ksi (340MPa) minimum yield strength, 65ksi (450MPa) minimum tensile strength, 68mil minimum thickness (14 gauge, 0.0713" design thickness) with ASTM A653/A653M G90 (Z275) hot dipped galvanized coating.

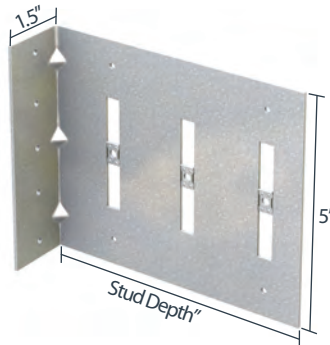

US Patents #8,181,419, #8,683,770 & #10,132,341

MasterClip VLB Allowable Loads

Rigid Connection: F1, F2, & F3 Load Directions										
Screw Patterns with #12 Screws	F1 Rigid Connection		F2 Rigid Connection			F3 Rigid Connection				
	VLB600	VLB800	VLB600	VLB600 & VLB800		VLB600			VLB800	
	3-4 Screws	3-4 Screws	2 Screws	3 Screws	4 Screws	2 Screws	3 Screws	4 Screws	3 Screws	4 Screws
33mil (20ga), 33ksi stud	191	182	377	565	754	251	377	503	332	441
33mil (20ga), 50ksi stud	275	182	544	817	1,089	362	544	727	479	637
43mil (18ga), 33ksi stud	248	182	561	841	1,122	373	561	749	494	656
43mil (18ga), 50ksi stud	359	182	810	1,215	1,620	539	810	1,082	713	948
54mil (16ga), 33ksi stud	312	182	789	1,183	1,577	524	789	1,053	694	923
54mil (16ga), 50ksi stud	450	182	1,139	1,709	1,811	757	1,139	1,521	1,002	1,269
68mil (14ga), 50ksi stud	536	182	1,610	1,811	1,811	1,071	1,610	1,792	1,269	1,269
97mil (12ga), 50ksi stud	536	182	1,698	1,811	1,811	1,129	1,698	1,792	1,269	1,269
Max Allowable Clip Load	536	182	1,811			1,792			1,269	

Vertical Deflection: F1 & F2 Load Directions				
Screw Patterns with #12 Screws	F1 - Deflection Connection		F2 - Deflection Connection	
	VLB600	VLB800	VLB600 & VLB800	
	2-3 Screws	2-3 Screws	2 Screws	3 Screws
33mil (20ga), 33ksi stud	95	95	377	565
33mil (20ga), 50ksi stud	138	107	544	817
43mil (18ga), 33ksi stud	124	107	561	841
43mil (18ga), 50ksi stud	179	107	810	1,215
54mil (16ga), 33ksi stud	156	107	789	1,183
54mil (16ga), 50ksi stud	225	107	1,139	1,567
68mil (14ga), 50ksi stud	227	107	1,567	1,567
97mil (12ga), 50ksi stud	227	107	1,567	1,567
Max Allowable Clip Load	227	107	1,567	

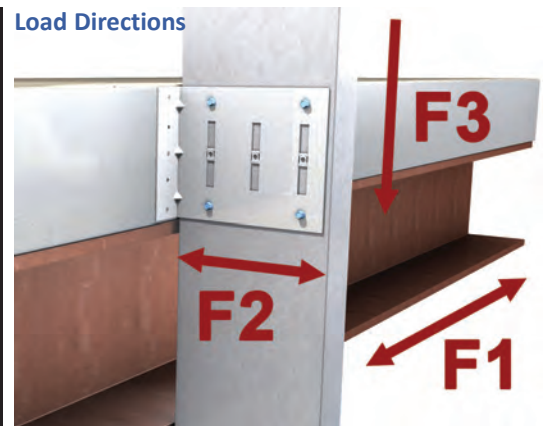

****Important notes for MasterClip VLB Allowable Load tables continued on next page.**

Vertical Deflection Screw Patterns

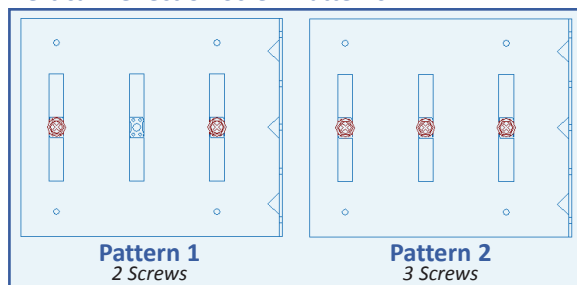

Rigid Connection Screw Patterns

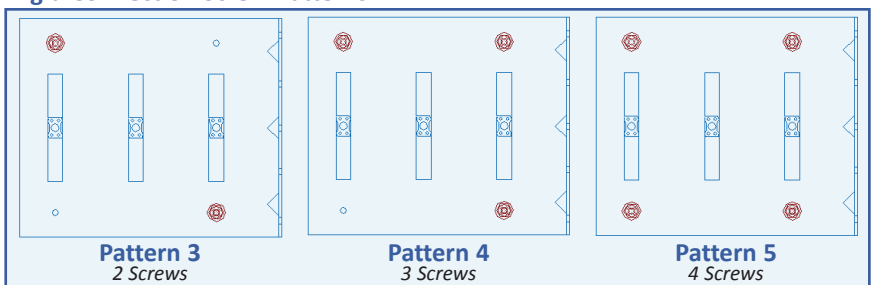

Notes:

- Allowable load tables incorporate eccentric loading of fasteners. Values with a welded connection may increase.
- Fasten within ¾" of the angle heel (centerline of the 1½" leg) to minimize eccentric load transfer.
- Fasteners attaching clips to structure should be installed symmetrically around the center line of the clip. The allowable load of the clip may be reduced if fasteners are not installed symmetrically.
- Guide holes in the 1 ½" leg measure 0.141" in diameter.
- Total vertical deflection up to 2" (1" up and 1" down).
- Allowable loads have not been increased for wind, seismic, or other factors.
- MasterClip VLB resists horizontal and vertical loads when used as a rigid connector.
- Loads listed reflect force in a single direction. When multiple loads react on the connection, it is the responsibility of the designer to check the interaction of forces.
- Torsional effects are considered on the screw group for F3 allowable loads. It is assumed that half of the torsional moment is taken by the connection to the structure and half is taken by the screw connection to the stud.
- Design loads consider loads on the clip and #12 screw fasteners to the stud web.
- (3) #12 screws are provided with each connector (based on number of integrated breakaway step bushings). Load requirements don't always require the use of all screws provided.
- Three slots are standard in 6" and higher web depths to accommodate construction tolerances. Use of a 3rd screw and bushing is dependent upon load requirements.

Nomenclature

MasterClip VLB is designated by type (VLB), followed by stud depth in inches multiplied by 100.

Example: 6" stud.

Designate: MasterClip® VLB600

Example Details

The attachment of MasterClip to the primary structure may be made with PAFs, screw/bolt anchors or welds and is dependent upon the base material (steel, concrete or CMU) and the design configuration.



MasterClip® VLB used for Vertical Deflection



MasterClip® VLB used as Rigid Connection

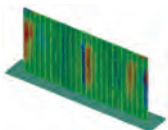

MasterClip VLB Series
 Blast and Seismic Design Data
www.steelnetwork.com

** For more information or to review a copy of this report, please visit our website at <http://www.steelnetwork.com/Site/TechnicalData>

DriftClip® DSLB

Bypass Slab

The Steel Network, Inc. 
 www.steelnetwork.com
 1-888-474-4876

Material Composition

ASTM A1003/A1003M Structural Grade 50 (340) Type H, ST50H (ST340H): 50ksi (340MPa) minimum yield strength, 65ksi (450MPa) minimum tensile strength, 97mil minimum thickness (12 gauge, 0.1017" design thickness) with ASTM A653/A653M G90 (Z275) hot dipped galvanized coating.

The attachment of DriftClip DSLB to the primary structure may be made with PAFs, screws, or bolt anchors depending on the base material (steel or concrete) and the design configuration. The step bushings used for attachment to structure are designed for use with 1/4" maximum diameter fasteners. Designing this connection is the responsibility of the Structural Engineer of Record, and a minimum of two fasteners must be used.

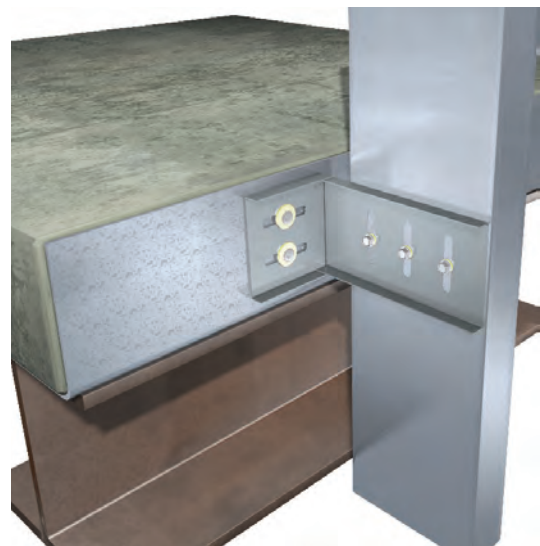
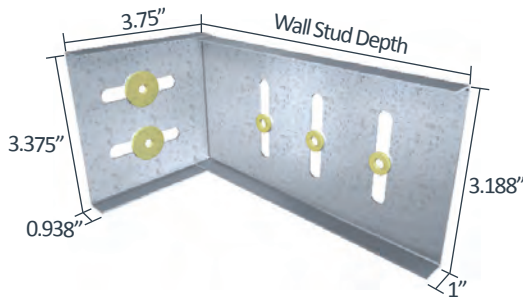

US Patent #6,612,087

DriftClip DSLB Allowable (Unfactored) Loads¹

DriftClip® DSLB362, 600 & 800 Recommended Allowable Load (lbs): F2					
Stud		Fastener Pattern 1		Fastener Pattern 2	
Thickness Mils (ga)	Yield Strength (ksi)	w/2 #12 Screws	w/3 #12 Screws*	w/2 #12 Screws	w/3 #12 Screws*
33 (20)	33	377	565	377	565
33 (20)	50	544	817	544	572
43 (18)	33	561	841	561	572
43 (18)	50	810	917	572	572
54 (16)	33	917	917	572	572
54 (16)	50	917	917	572	572
68 (14)	50	917	917	572	572
97 (12)	50	917	917	572	572
Max Allowable Clip Load		917		572	

Notes:

- Design loads are for attachment of DriftClip DSLB to stud only.
- Attachment to structure engineered by others. As a design reference for the structure attachment, follow ICC-ESR-3332 for allowable loads for screw fasteners of 1/4" - 20 size with various plate thickness.
- Allowable loads have not been increased for wind, seismic, or other factors.
- #12 screws are provided with each step bushing for attachment to stud. Load requirements don't always justify use of a third screw.
- DriftClip DSLB allows up to 2" of vertical deflection (1" up and 1" down), and 2" lateral drift (1" left and 1" right in plane). Deflection requirements greater than 2" lateral drift are available.
- One row of bridging is recommended at a maximum distance of 18" from DriftClip to resist torsional effects.

¹ For LRFD Design Strengths refer to ICC-ESR-2049.

* Three screws are not applicable to DriftClip DSLB362.

Nomenclature

DriftClip DSLB is classified by multiplying stud depth by 100.*

Example: 6" stud depth

Designate: DriftClip® DSLB600

* Parts with the designation "-CA" on the end of the part name includes a special bushing available to allow connection to the side of the concrete slab using two 1/4" concrete screw anchors.

** If more than 2" lateral drift is required, contact TSN engineering.

Allowable Screw Pullout

Section Thickness	Pullout 1/4" - 20 Screws* (lbs)
0.0566"	206
0.0713"	260
0.1017"	500
1/8"	765
3/16"	1,045
1/4"	1,215
5/16"	1,275

* Limited by the allowable F2 loads shown in the table on the left.

Load Direction



Fastener Patterns

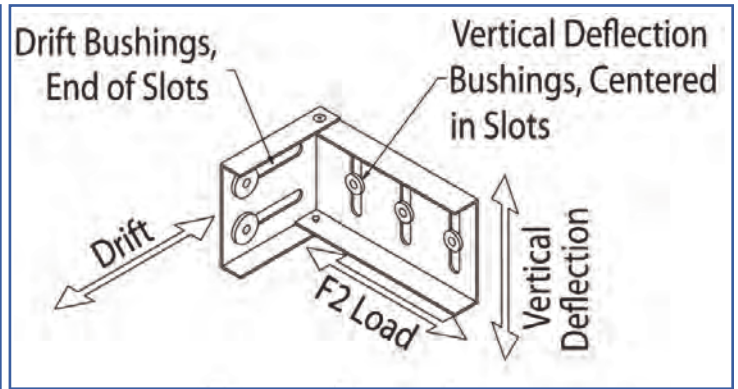
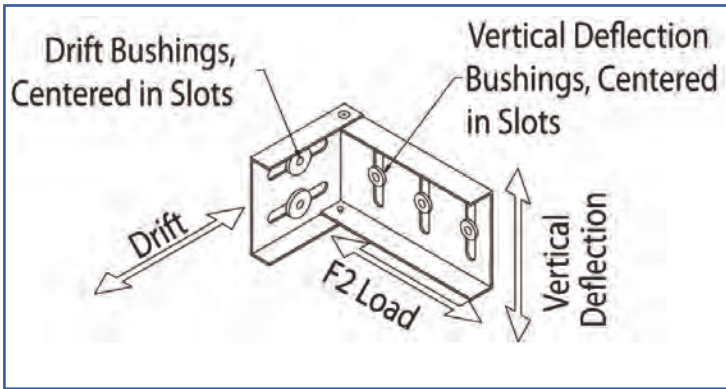

Fastener Pattern 1 replicates a condition of out-of-plane wind or seismic force with no vertical live load deflection or in-plane drift.

Fastener Pattern 2 replicates a condition of out-of-plane wind or seismic force with or without full vertical live load deflection and full in-plane drift.



DriftClip DSLB362/400,
 DSLB600 & DSLB800
 ICC-ESR-2049
 www.icc-es.org

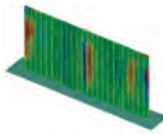

DriftClip DSLB Series
 Blast and Seismic Design Data
 www.steelnetwork.com

** For more information or to review a copy of each of these reports, please visit our website at <http://www.steelnetwork.com/Site/TechnicalData>

DriftClip® DSLS

Bypass Structure

The Steel Network, Inc. 
 www.steelnetwork.com
 1-888-474-4876

Material Composition

ASTM A1003/A1003M Structural Grade 50 (340) Type H, ST50H (ST340H): 50ksi (340MPa) minimum yield strength, 65ksi (450MPa) minimum tensile strength, 97mil minimum thickness (12 gauge, 0.1017" design thickness) with ASTM A653/A653M G90 (Z275) hot dipped galvanized coating.

The attachment of DriftClip DSLS to the primary structure may be made with PAFs, screws, or bolt anchors depending on the base material (steel or concrete) and the design configuration. The step bushings used for attachment to structure are designed for use with ¼" maximum diameter fasteners. Designing this connection is the responsibility of the Structural Engineer of Record, and a minimum of two fasteners must be used. A minimum of 3.5" of DSLS is required for attachment to steel structure and a minimum of 6" is required for attachment to concrete structure.

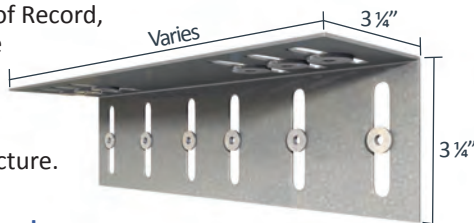

US Patent #6,612,087

DriftClip DSLS Allowable (Unfactored) Loads¹

DriftClip® DSLS, Recommended Allowable Load (lbs): F2 - Fastener Pattern 1									
Stud		DSLS362/400-9	DSLS362/400-12	DSLS600-10		DSLS600-12		DSLS600-15	
Thickness Mils (ga)	Yield Strength (ksi)	w/2 #12 Screws	w/2 #12 Screws	w/2 #12 Screws	w/3 #12 Screws	w/2 #12 Screws	w/3 #12 Screws	w/2 #12 Screws	w/3 #12 Screws
33 (20)	33	377	377	377	565	377	565	377	565
33 (20)	50	544	544	544	817	544	817	544	817
43 (18)	33	561	561	561	841	561	841	561	841
43 (18)	50	810	810	810	1,204	810	1,215	810	1,215
54 (16)	33	789	789	789	1,183	789	1,183	789	1,183
54 (16)	50	961	1,139	1,139	1,204	1,139	1,709	1,139	1,709
68 (14)	50	961	1,237	1,204	1,204	1,610	1,862	1,610	1,903
97 (12)	50	961	1,237	1,204	1,204	1,698	1,862	1,698	1,903
Max Allowable Clip Load		961	1,237	1,204		1,862		1,903	

DriftClip® DSLS, Recommended Allowable Load (lbs): F2 - Fastener Pattern 1									
Stud		DSLS600-20		DSLS800-12		DSLS800-15		DSLS800-20	
Thickness Mils (ga)	Yield Strength (ksi)	w/2 #12 Screws	w/3 #12 Screws	w/2 #12 Screws	w/3 #12 Screws	w/2 #12 Screws	w/3 #12 Screws	w/2 #12 Screws	w/3 #12 Screws
33 (20)	33	377	565	377	565	377	565	377	565
33 (20)	50	544	817	544	817	544	817	544	817
43 (18)	33	561	841	561	841	561	841	561	841
43 (18)	50	810	1,215	810	1,164	810	1,215	810	1,215
54 (16)	33	789	1,183	789	1,164	789	1,183	789	1,183
54 (16)	50	1,139	1,709	1,139	1,164	1,139	1,709	1,139	1,709
68 (14)	50	1,610	2,236	1,164	1,164	1,610	1,894	1,610	1,822
97 (12)	50	1,698	2,236	1,164	1,164	1,698	1,894	1,698	1,822
Max Allowable Clip Load		2,236		1,164		1,894		1,822	

DriftClip® DSLS, Recommended Allowable Load (lbs): F2 - Fastener Pattern 2									
Stud		DSLS362/400-9	DSLS362/400-12	DSLS600-10		DSLS600-12		DSLS600-15	
Thickness Mils (ga)	Yield Strength (ksi)	w/2 #12 Screws	w/2 #12 Screws	w/2 #12 Screws	w/3 #12 Screws	w/2 #12 Screws	w/3 #12 Screws	w/2 #12 Screws	w/3 #12 Screws
33 (20)	33	377	377	377	565	377	565	377	565
33 (20)	50	544	544	544	817	544	817	544	817
43 (18)	33	561	561	561	841	561	841	561	841
43 (18)	50	810	810	810	1,018	810	1,215	810	1,215
54 (16)	33	789	789	789	1,018	789	1,183	789	1,183
54 (16)	50	943	1,078	1,018	1,018	1,139	1,709	1,139	1,709
68 (14)	50	943	1,078	1,018	1,018	1,610	1,742	1,610	1,903
97 (12)	50	943	1,078	1,018	1,018	1,698	1,742	1,698	1,903
Max Allowable Clip Load		943	1,078	1,018		1,742		1,903	

****DriftClip DSLS Allowable Load tables and important notes continued on next page.**

DriftClip® DSLS, Recommended Allowable Load (lbs): F2 - Fastener Pattern 2									
Stud		DSLS600-20		DSLS800-12		DSLS800-15		DSLS800-20	
Thickness Mills (ga)	Yield Strength (ksi)	w/2 #12 Screws	w/3 #12 Screws	w/2 #12 Screws	w/3 #12 Screws	w/2 #12 Screws	w/3 #12 Screws	w/2 #12 Screws	w/3 #12 Screws
33 (20)	33	377	565	377	565	377	565	377	565
33 (20)	50	544	817	544	817	544	817	544	817
43 (18)	33	561	841	561	841	561	841	561	841
43 (18)	50	810	1,215	810	1,158	810	1,198	810	1,215
54 (16)	33	789	1,183	789	1,158	789	1,183	789	1,183
54 (16)	50	1,139	1,663	1,139	1,158	1,139	1,198	1,139	1,246
68 (14)	50	1,610	1,663	1,158	1,158	1,198	1,198	1,246	1,246
97 (12)	50	1,663	1,663	1,158	1,158	1,198	1,198	1,246	1,246
Max Allowable Clip Load		1,663		1,158		1,198		1,246	

Notes:

- Design loads are for attachment of DriftClip DSLS to stud only. Load tables reflect horizontal loads (F2)
- Attachment to structure engineered by others. As a design reference, follow ICC-ESR-3332 for allowable loads for screw fasteners of 1/4"- 20 size with various plate thickness.
- Allowable loads have not been increased for wind, seismic, or other factors.
- #12 screws are provided with each step bushing for attachment to stud. Load requirements don't always justify use of a third screw.
- One row of bridging is recommended at a maximum distance of 18" from DriftClip to resist torsional effects.
- Return lip added for clips longer than 20".
- DriftClip DSLS allows up to 2" of vertical deflection (1" up and 1" down), and 2" lateral drift (1" left and 1" right in plane). Deflection requirements greater than 2" lateral drift are available.

¹ For LRFD Design Strengths for DSLS600-12 and DSLS600-15 refer to ICC-ESR-2049.

Load Direction



Nomenclature

DriftClip DSLS is classified by multiplying stud depth by 100, followed by length.

Example: 6" stud depth, 15" length

Designate: DriftClip® DSLS600-15

* If more than 2" lateral drift is required, contact TSN engineering.

** Three screws & step bushings are available for attachment to stud in 6" sizes and higher. Specify that 3 slots are needed when placing order.

Fastener Patterns

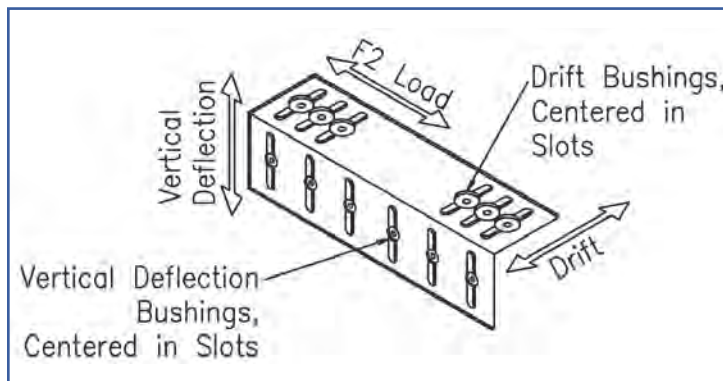

Fastener Pattern 1 replicates a condition of out-of-plane wind or seismic force with no vertical live load deflection or in-plane drift.

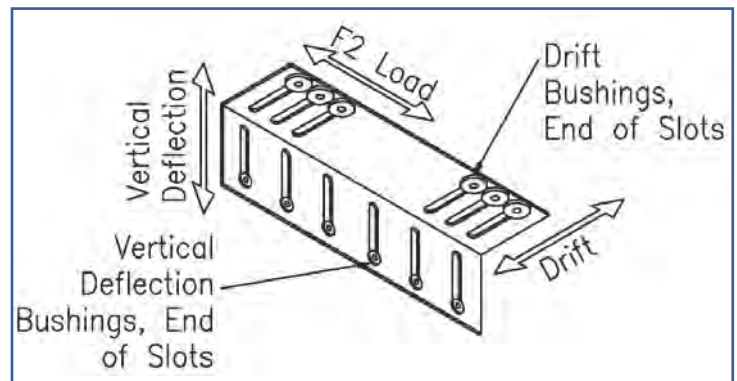

Fastener Pattern 2 replicates a condition of out-of-plane wind or seismic force with full vertical live load deflection and full in-plane drift.



DriftClip DSLS600-12 & DSLS600-15
ICC-ESR-2049
www.icc-es.org

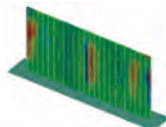

DriftClip DSLS Series
Blast and Seismic Design Data
www.steelnetwork.com

** For more information or to review a copy of each of these reports, please visit our website at <http://www.steelnetwork.com/Site/TechnicalData>

DriftClip® DSLD

Interior Head of Wall

Material Composition

ASTM A1003/A1003M Structural Grade 50 (340) Type H, ST50H (ST340H): 50ksi (340MPa) minimum yield strength, 65ksi (450MPa) minimum tensile strength, 33mil minimum thickness (20 gauge, 0.0346" design thickness) with ASTM A653/A653M G60 (Z180) hot dipped galvanized coating.

The attachment of DriftClip DSLD to the primary structure utilizes step bushings designed for #8 (0.164") screws. Designing this connection is the responsibility of the Structural Engineer of Record, and a minimum of two fasteners must be used.

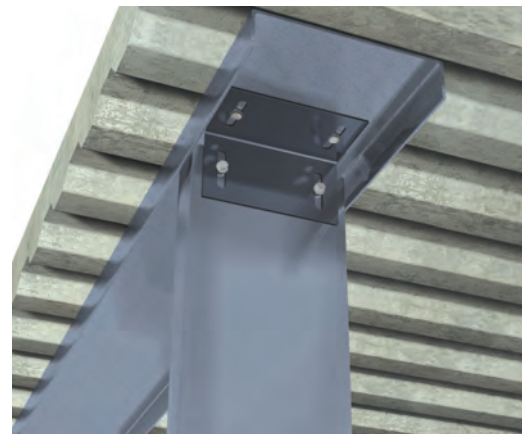
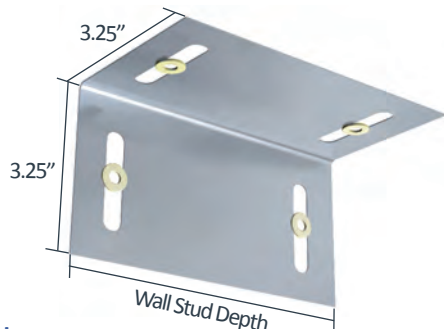

US Patent #6,612,087

DriftClip DSLD Allowable (Unfactored) Loads¹

DriftClip® DSLD, Recommended Allowable Load (lbs): F2							
Stud		Fastener Pattern 1			Fastener Pattern 2		
Thickness Mils (ga)	Yield Strength (ksi)	DSLDD362 w/2 #8 Screws	DSLDD600 w/2 #8 Screws	DSLDD800 w/2 #8 Screws	DSLDD362 w/2 #8 Screws	DSLDD600 w/2 #8 Screws	DSLDD800 w/2 #8 Screws
18 (25)	33	70	132	132	27	107	132
27 (22)	33	70	178	199	27	107	183
33 (20)	33	70	178	199	27	107	183
33 (20)	50	70	178	199	27	107	183
43 (18)	33	70	178	199	27	107	183
43 (18)	50	70	178	199	27	107	183
54 (16)	33	70	178	199	27	107	183
54 (16)	50	70	178	199	27	107	183
Maximum Allowable Clip Load		70	178	199	27	107	183

Notes:

- Design loads are for attachment of DriftClip DSLD to stud only. Load tables reflect horizontal loads (F2).
- Attachment to structure engineered by others.
- Allowable loads have not been increased for wind, seismic, or other factors.
- Two (2) #8 screws are provided with each DriftClip DSLD for attachment to stud.
- DriftClip DSLD allows up to 2" of vertical deflection (1" up and 1" down), and 2" lateral drift (1" left and 1" right in plane). Deflection requirements greater than 2" lateral drift are available.

¹ For LRFD Design Strengths refer to ICC-ESR-2049.

Nomenclature

DriftClip DSLD is classified by multiplying stud depth by 100.

Example: 6" stud depth

Designate: DriftClip® DSLD600

* Three screws & step bushings are available in 6" sizes and higher. Specify that 3 slots are needed when placing order.

Load Direction



Fastener Patterns

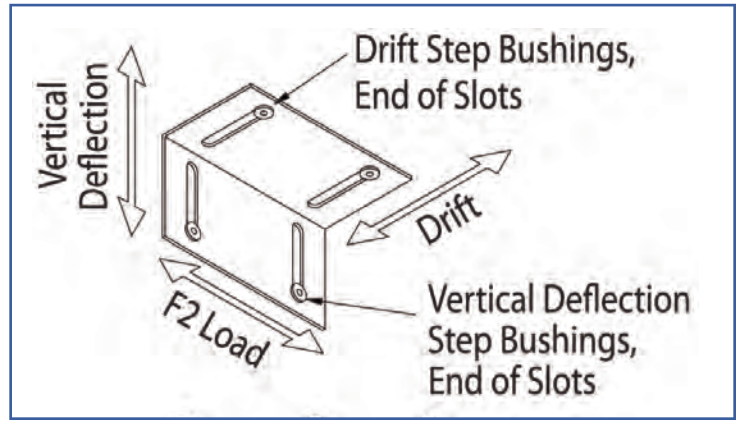
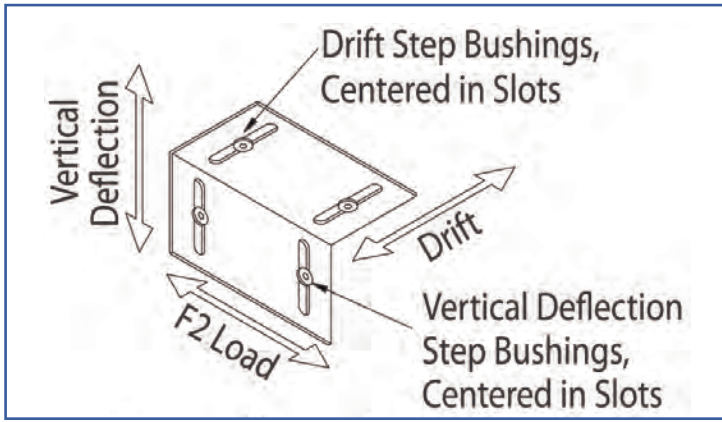

Fastener Pattern 1 replicates a condition of out-of-plane wind or seismic force with no vertical live load deflection or in-plane drift.

Fastener Pattern 2 replicates a condition of out-of-plane wind or seismic force with full vertical live load deflection and full in-plane drift.



UL2079 Head of Wall Assemblies



DriftClip DSLD362/400, DSLS600 & DSLD800
ICC-ESR-2049
www.icc-es.org

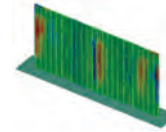

DriftClip DSLD Series Blast and Seismic Design Data
www.steelnetwork.com

** For more information or to review a copy of each of these reports, please visit our website at <http://www.steelnetwork.com/Site/TechnicalData>

DriftClip® DSL

Exterior Head of Wall



Material Composition

ASTM A1003/A1003M Structural Grade 50 (340) Type H, ST50H (ST340H): 50ksi (340MPa) minimum yield strength, 65ksi (450MPa) minimum tensile strength, 97mil minimum thickness (12 gauge, 0.1017" design thickness) with ASTM A653/A653M G90 (Z275) hot dipped galvanized coating.

The attachment of DriftClip DSL to the primary structure may be made with PAFs, screws, or bolt anchors depending on the base material (steel or concrete) and the design configuration. The step bushings used for attachment to structure are designed for use with ¼" maximum diameter fasteners. Designing this connection is the responsibility of the Structural Engineer of Record, and a minimum of two fasteners must be used.

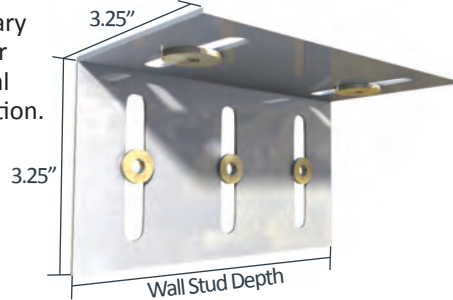

US Patent #6,612,087

DriftClip DSL Allowable (Unfactored) Loads¹

DriftClip® DSL, Recommended Allowable Load (lbs): F2												
Stud		Fastener Pattern 1					Fastener Pattern 2					
Thickness Mils (ga)	Yield Strength (ksi)	DSL362 w/2 #12 Screws	DSL600 w/2 #12 Screws	DSL600 w/3 #12 Screws	DSL800 w/2 #12 Screws	DSL800 w/3 #12 Screws	DSL362 w/2 #12 Screws	DSL600 w/2 #12 Screws	DSL600 w/3 #12 Screws	DSL800 w/2 #12 Screws	DSL800 w/3 #12 Screws	
33 (20)	33	357	377	565	377	565	129	377	418	377	565	
33 (20)	50	357	544	776	544	817	129	418	418	544	817	
43 (18)	33	357	561	776	561	841	129	418	418	560	841	
43 (18)	50	357	776	776	810	1,041	129	418	418	810	1,041	
54 (16)	33	357	776	776	789	1,041	129	418	418	789	1,041	
54 (16)	50	357	776	776	1,041	1,041	129	418	418	1,041	1,041	
68 (14)	50	357	776	776	1,041	1,041	129	418	418	1,041	1,041	
97 (12)	50	357	776	776	1,041	1,041	129	418	418	1,041	1,041	
Max Allowable Clip Load		357	776	1,041	1,041	1,041	129	418	418	1,041	1,041	

Notes:

- Design loads are for attachment of DriftClip DSL to stud only. Load tables reflect horizontal loads (F2).
- Attachment to structure engineered by others.
- Allowable loads have not been increased for wind, seismic, or other factors.
- Two (2) #12 screws are provided with each DriftClip DSL for attachment to stud.
- DriftClip DSL allows up to 2" of vertical deflection (1" up and 1" down), and 2" lateral drift (1" left and 1" right in plane). Deflection requirements greater than 2" lateral drift are available.
- One row of bridging is recommended at a maximum distance of 18" from DriftClip to resist torsional effects.
- Attachment to structure engineered by others. As a design reference, follow ICC-ESR-3332 for allowable loads for screw fasteners of ¼" - 20 size with various plate thickness.

¹ For LRFD Design Strengths refer to ICC-ESR-2049.

Nomenclature

DriftClip DSL is classified by multiplying stud depth by 100.*

Example: 6" stud depth

Designate: DriftClip® DSL600

* Parts with the designation "-CA" on the end of the part name includes a special bushing available to allow connection to the side of the concrete slab using two ¼" concrete screw anchors

** If more than 2" lateral drift is required, contact TSN engineering.

*** Three screws & step bushings are available in 6" sizes and higher. Specify that 3 slots are needed when placing order.

Load Direction



Fastener Patterns

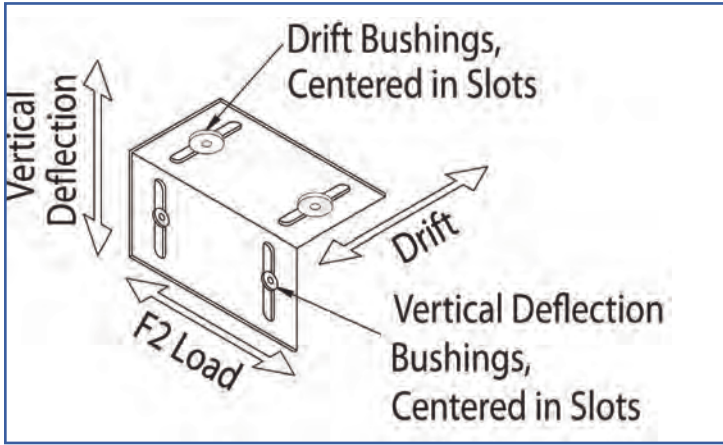

Fastener Pattern 1 replicates a condition of out-of-plane wind or seismic force with no vertical live load deflection or in-plane drift.

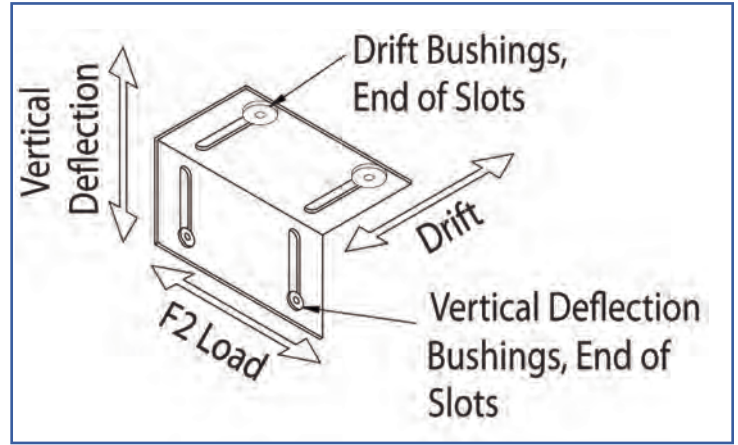

Fastener Pattern 2 replicates a condition of out-of-plane wind or seismic force with full vertical live load deflection and full in-plane drift.



DriftClip DSL362/400,
DSL600 & DSL800
ICC-ESR-2049
www.icc-es.org

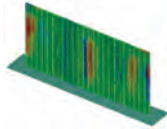

DriftClip DSL Series
Blast and Seismic Design Data
www.steelnetwork.com

** For more information or to review a copy of each of these reports, please visit our website at <http://www.steelnetwork.com/Site/TechnicalData>

DriftTrak® DTSL

Exterior Head of Wall

The Steel Network, Inc. 
 www.steelnetwork.com
 1-888-474-4876

Material Composition

Clip Material: ASTM A1003/A1003M Structural Grade 50 (340) Type H, ST50H (ST340H): 50ksi (340MPa) minimum yield strength, 65ksi (450MPa) minimum tensile strength, 68mil minimum thickness (14 gauge, 0.0713" design thickness) with ASTM A653/A653M G90 (Z275) hot dipped galvanized coating.

Track Material: ASTM A1003/A1003M Structural Grade 50 (340) Type H, ST50H (ST340H): 50ksi (340MPa) minimum yield strength, 65ksi (450MPa) minimum tensile strength, 97mil minimum thickness (12 gauge, 0.1017" design thickness) with ASTM A653/A653M G60 (Z180) hot dipped galvanized coating.

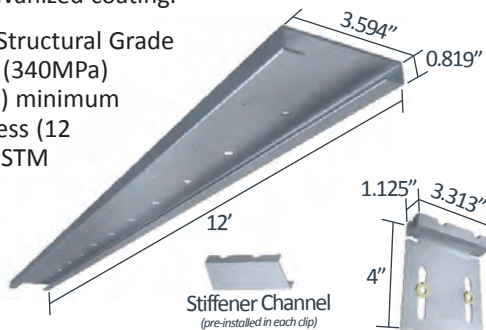

US Patent #7,503,150

DriftTrak DTSL Allowable (Unfactored) Loads¹

DriftTrak® DTSL, Recommended Allowable Load (lbs): F2					
Stud		8" Fastener Spacing in Track to Structure (or welded on both sides)		16" Fastener Spacing in Track to Structure (or welded on both sides)	
		Fastener Pattern 1	Fastener Pattern 2	Fastener Pattern 1	Fastener Pattern 2
Thickness Mils (ga)	Yield Strength (ksi)	w/2 #12 Screws	w/2 #12 Screws	w/2 #12 Screws	w/2 #12 Screws
33 (20)	33	377	377	377	377
33 (20)	50	544	482	544	449
43 (18)	33	561	482	561	449
43 (18)	50	625	482	625	449
54 (16)	33	625	482	625	449
54 (16)	50	625	482	625	449
68 (14)	50	625	482	625	449
97 (12)	50	625	482	625	449
Maximum Allowable Clip Load		625	482	625	449

Notes:

- Design loads are for attachment of DriftTrak DTSL to stud only. Load tables reflect horizontal loads (F2).
- Attachment to structure engineered by others.
- Allowable loads have not been increased for wind, seismic, or other factors.
- Two (2) #12 screws are provided with each DriftTrak DTSL for attachment to stud.
- Clips are manufactured to fit into the DriftTrak and provide up to 2" of vertical deflection (1" up and 1" down), and free lateral movement of the structure.
- Allow a minimum of 0.875" from the structure to the top of the stud to allow for the attachment of DriftTrak inside the standard track.
- One row of bridging is recommended at a maximum distance of 18" from DriftTrak to resist torsional effects.
- DriftTrak DTSL does not provide wall closure. A top track will be required for closure of the wall assembly.

¹ For LRFD Design Strengths refer to ICC-ESR-2049.

Nomenclature

DriftTrak DTSL is available in one size for all stud depths over 3 5/8".

Example: 6" stud depth

Designate: DriftTrak® DTSL

* DriftTrak is available in 12' lengths, and is designated: DriftTrak®

** A top track is required for closure of the wall assembly.

*** Clips and track sold separately.

Load Direction

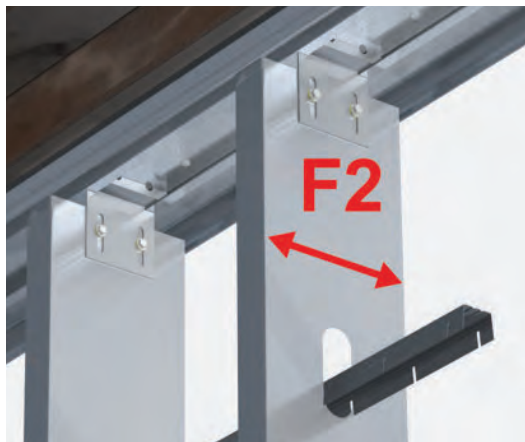

Fastener Patterns

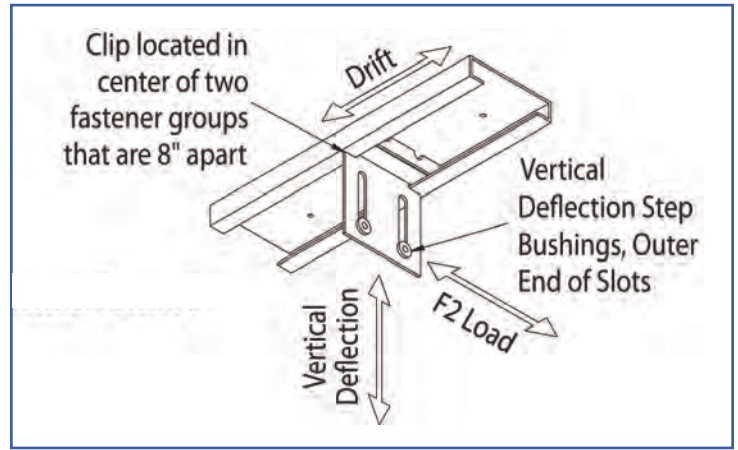
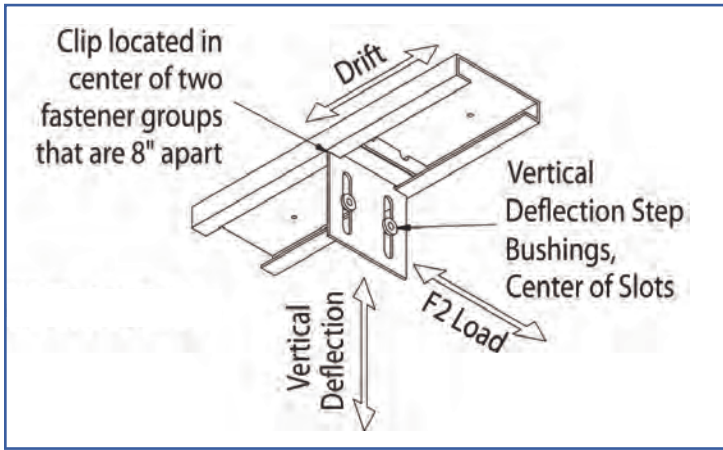

Fastener Pattern 1 replicates a condition of out-of-plane wind or seismic force with no vertical live load deflection and full in-plane drift.

Fastener Pattern 2 replicates a condition of out-of-plane wind or seismic force with full vertical live load deflection and full in-plane drift.

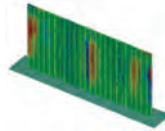

DriftTrak DTSL Series
Blast and Seismic Design Data
www.steelnetwork.com

** For more information or to review a copy of each of these reports, please visit our website at <http://www.steelnetwork.com/Site/TechnicalData>

DriftTrak® DTSLB

Bypass Slab

Material Composition

DTSLB Clip Material: ASTM A1003/A1003M Structural Grade 50 (340) Type H, ST50H (ST340H): 50ksi (340MPa) minimum yield strength, 65ksi (450MPa) minimum tensile strength, 68mil minimum thickness (14 gauge, 0.0713" design thickness) with ASTM A653/A653M G90 (Z275) hot dipped galvanized coating.

DTSLB-HD Clip and Track Material: ASTM A1003/A1003M Structural Grade 50 (340) Type H, ST50H (ST340H): 50ksi (340MPa) minimum yield strength, 65ksi (450MPa) minimum tensile strength, 97mil minimum thickness (12 gauge, 0.1017" design thickness) with ASTM A653/A653M G60 (Z180) hot dipped galvanized coating.

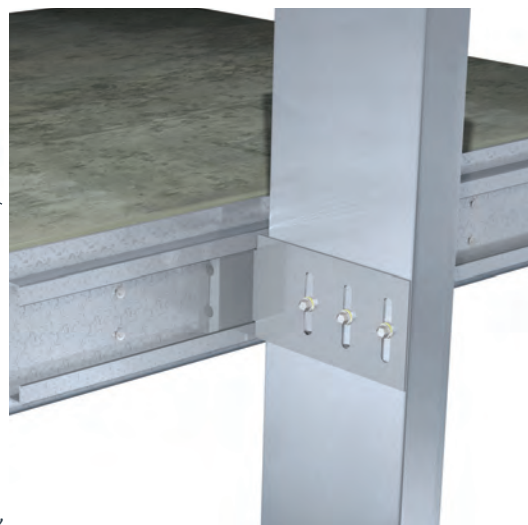
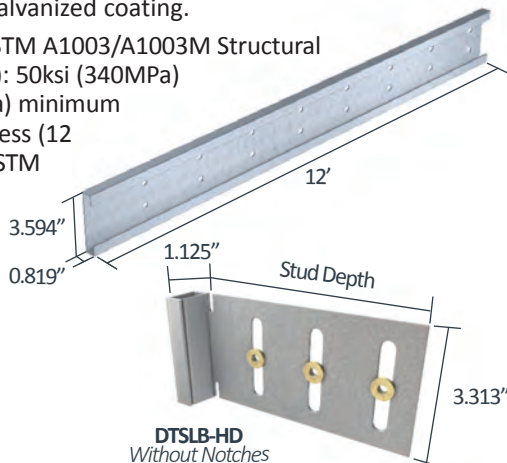
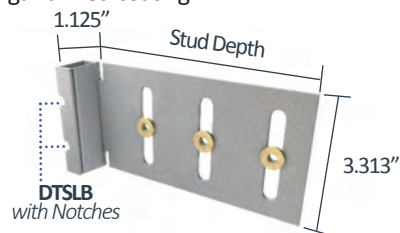

US Patent #7,503,150

DriftTrak DTSLB Allowable (Unfactored) Loads¹

DriftTrak® DTSLB & DTSLB-HD, Recommended Allowable Load (lbs): F2									
Stud		DTSLB				DTSLB-HD			
		8" Fastener Spacing in Track to Structure (or welded on each side)		16" Fastener Spacing in Track to Structure (or welded on each side)		8" Fastener Spacing in Track to Structure (or welded on each side)		16" Fastener Spacing in Track to Structure (or welded on each side)	
Thickness Mils (ga)	Yield Strength (ksi)	w/2 #12 Screws	w/3 #12 Screws	w/2 #12 Screws	w/3 #12 Screws	w/2 #12 Screws	w/3 #12 Screws	w/2 #12 Screws	w/3 #12 Screws
33 (20)	33	377	565	377	565	377	565	377	565
33 (20)	50	544	808	544	753	544	817	544	817
43 (18)	33	561	808	561	753	561	841	561	841
43 (18)	50	808	808	753	753	810	1,215	810	953
54 (16)	33	789	808	753	753	789	1,183	789	953
54 (16)	50	808	808	753	753	1,139	1,618	953	953
68 (14)	50	808	808	753	753	1,610	1,618	953	953
97 (12)	50	808	808	753	753	1,618	1,618	953	953
Maximum Allowable Clip Load		808		753		1,618		953	

Notes:

- Design loads are for attachment of DriftTrak DTSLB to stud only. Load tables reflect horizontal loads (F2).
- Attachment to structure engineered by others.
- Allowable loads have not been increased for wind, seismic, or other factors.
- #12 screws are provided with each step bushing for attachment to stud. Load requirements don't always justify use of a third screw.
- Clips are manufactured to fit into the DriftTrak and provide up to 2" of vertical deflection (1" up and 1" down), and free lateral movement of the structure.
- Allow a minimum of 0.875" from the structure to the inside flange of the bypassing stud to allow for track attachment. Standard offset of stud from the open face of the track should not exceed 1.25".
- One row of bridging is recommended at a maximum distance of 18" from DriftTrak if no other stud lateral restraint is present.

¹ For LRFD Design Strengths refer to ICC-ESR-2049.

Nomenclature

DriftTrak DTSLB is classified by multiplying stud depth by 100, followed by "HD," based on F2 strength required. Refer to load tables.*

Example: 6" stud depth, with an outward load (F2) of 1,000 lbs

Designate: DriftTrak® DTSLB600-HD

* Notches are standard in DriftTrak DTSLB. For greater F2 outward load capacity, use DTSLB-HD clips w/o notches. Refer to Allowable Load Table.

Load Direction

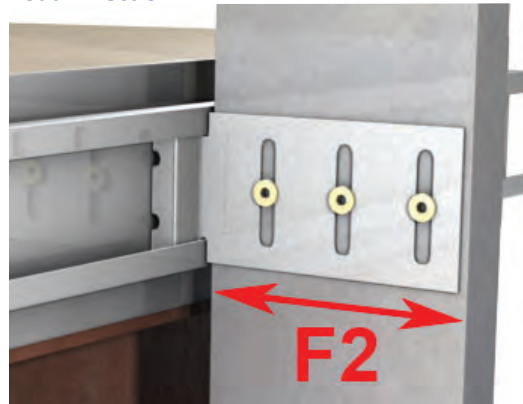

Fastener Patterns

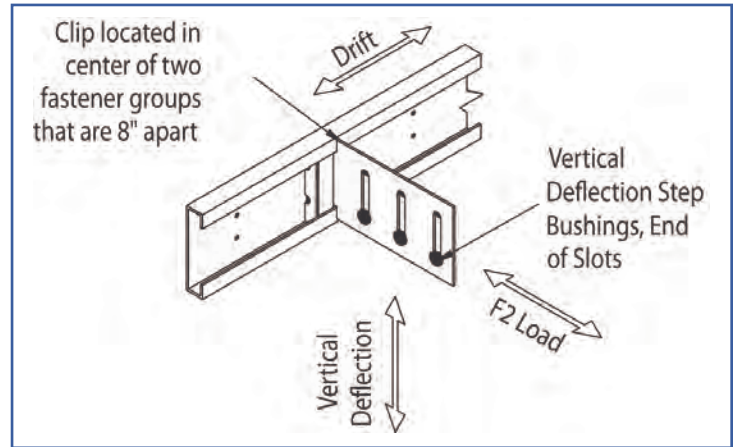
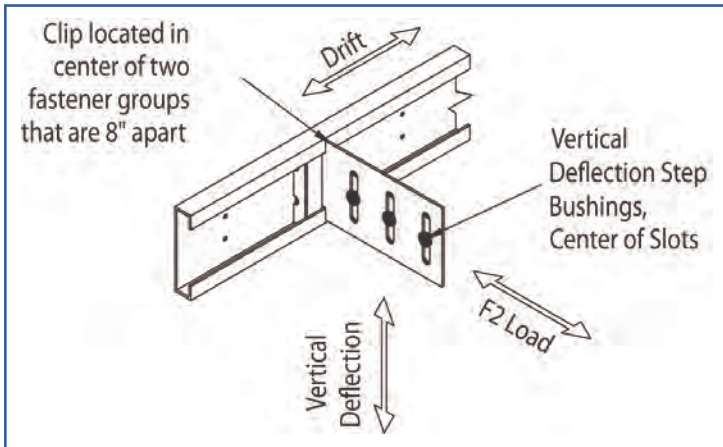

Fastener Pattern 1 replicates a condition of out-of-plane wind or seismic force with no vertical live load deflection and full in-plane drift.

Fastener Pattern 2 replicates a condition of out-of-plane wind or seismic force with full vertical live load deflection and full in-plane drift.

Locking of Lateral Movement After Panel Installation

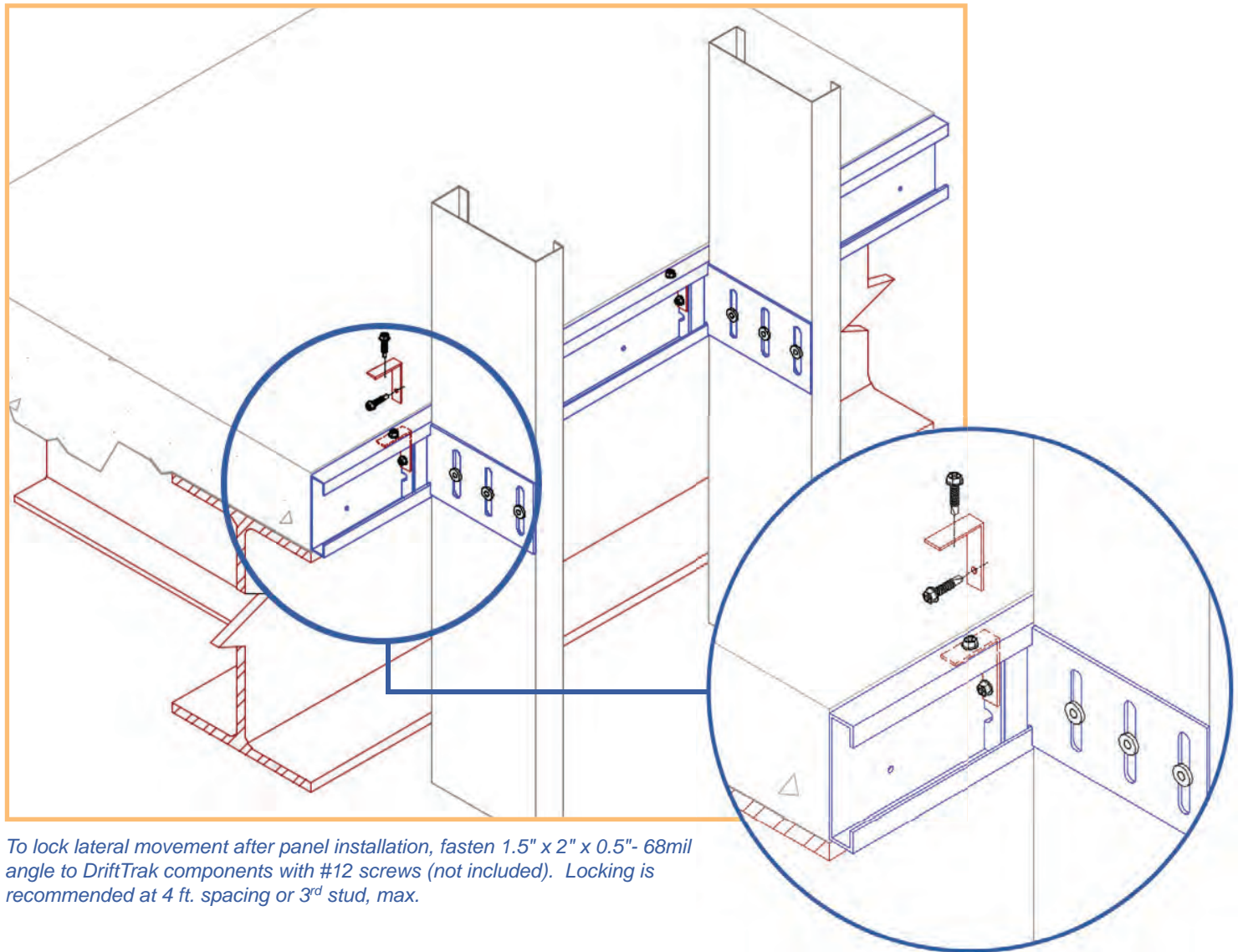

To lock lateral movement after panel installation, fasten 1.5" x 2" x 0.5"- 68mil angle to DriftTrak components with #12 screws (not included). Locking is recommended at 4 ft. spacing or 3rd stud, max.



DriftTrak DTSLB362/400,
DTSLB600 & DTSLB800
ICC-ESR-2049
www.icc-es.org

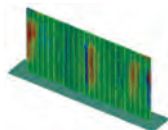

DriftTrak DTSLB Series
Blast and Seismic Design Data
www.steelnetwork.com

** For more information or to review a copy of each of these reports, please visit our website at <http://www.steelnetwork.com/Site/TechnicalData>

DriftTrak® DTLB

Bypass Slab

The Steel Network, Inc. 
www.steelnetwork.com
1-888-474-4876

Material Composition

Clip Material: ASTM A1003/A1003M Structural Grade 50 (340) Type H, ST50H (ST340H): 50ksi (340MPa) minimum yield strength, 65ksi (450MPa) minimum tensile strength, 97mil minimum thickness (12 gauge, 0.1017" design thickness) with ASTM A653/A653M G90 (Z275) hot dipped galvanized coating.

Track Material: ASTM A1003/A1003M Structural Grade 50 (340) Type H, ST50H (ST340H): 50ksi (340MPa) minimum yield strength, 65ksi (450MPa) minimum tensile strength, 97mil minimum thickness (12 gauge, 0.1017" design thickness) with ASTM A653/A653M G60 (Z180) hot dipped galvanized coating.



US Patent #7,503,150

DriftTrak DTLB Allowable (Unfactored) Loads

DriftTrak® DTLB & DTLB-HD, Recommended Allowable Load (lbs): F2 & F3												
Screw Patterns with #12 Screws	F2 Load Direction						F3 Load Direction					
	DTLB362/400 with Notches	DTLB362/400-HD w/o Notches	DTLB600 & DTLB800 with Notches		DTLB600-HD & DTLB800-HD w/o Notches		DTLB362/400 & DTLB362/400-HD Total Offset = 1"		DTLB600 & DTLB600-HD Total Offset = 1"		DTLB800 & DTLB800-HD Total Offset for 8" Studs = 1" Total Offset for 6" Studs = 3"	
	4 Screws	4 Screws	4 Screws	6 Screws	4 Screws	6 Screws	4 Screws	4 Screws	6 Screws	4 Screws	6 Screws	
33mil (20ga), 33ksi stud	752	752	752	1,128	752	1,128	227	258	308	226	263	
33mil (20ga), 50ksi stud	1,009	1,088	1,088	1,197	1,088	1,632	329	373	446	326	381	
43mil (18ga), 33ksi stud	1,009	1,120	1,120	1,197	1,120	1,680	339	384	459	336	392	
43mil (18ga), 50ksi stud	1,009	1,316	1,197	1,197	1,620	1,749	490	555	664	486	567	
54mil (16ga), 33ksi stud	1,009	1,316	1,197	1,197	1,576	1,749	477	540	646	473	552	
54mil (16ga), 50ksi stud	1,009	1,316	1,197	1,197	1,749	1,749	688	780	933	683	797	
68mil (14ga), 50ksi stud	1,009	1,316	1,197	1,197	1,749	1,749	940	1,064	1,274	932	1,088	
97mil (12ga), 50ksi stud	1,009	1,316	1,197	1,197	1,749	1,749	940	1,064	1,274	932	1,088	
Max Allowable Clip Load	1,009	1,316	1,197		1,749		1,163	1,750		1,272		

Notes:

- DTLB and DTLB-HD clips are manufactured to fit into the DriftTrak and provide up to 2" of vertical deflection (1" up and 1" down) while allowing free lateral movement of the structure.
- DTLB and DTLB-HD clips are manufactured to fit into the DriftTrak and provide a rigid connection to the stud while allowing free lateral movement of the structure.
- Design loads are for attachment of DriftTrak DTLB and DTLB-HD to stud only. Load tables reflect horizontal loads (F2).
- Design loads are for attachment of DriftTrak DTLB and DTLB-HD to stud only. Load tables reflect horizontal loads (F2) and vertical loads (F3).
- Loads listed reflect force in a single direction. When multiple loads react on the connection, it is the responsibility of the designer to check the interaction of forces.
- Torsional effects are considered on screw group for F3 allowable loads. It is assumed that all of the torsional moment is taken by the connection to the stud.
- Attachment to structure engineered by others.
- Allowable loads have not been increased for wind, seismic, or other factors.
- #12 screws are provided with DTLB and DTLB-HD clips for each step bushing for attachment to stud. Load requirements don't always justify use of a third screw.
- Use 8" DriftTrak fastener spacing to structure (or welded on each side of track) for DTLB and DTLB-HD clips. 8" spacing or 16" spacing can be used for DTLB and DTLB-HD clips. Size of fasteners or weld is engineered by others.
- Notches are standard in DriftTrak DTLB and DTLB. For greater F2 and F3 load capacities, use DTLB-HD and DTLB-HD clips w/o notches. Refer to allowable load tables.
- One row of bridging is recommended at a maximum distance of 18" from DriftTrak if no other stud lateral restraint is present.
- Allow a minimum of 0.875" from the structure to the inside flange of the bypassing stud to allow for track attachment.
- Total Offset is measured as track flange width plus the gap from the open face of the track to the inside face of the stud.

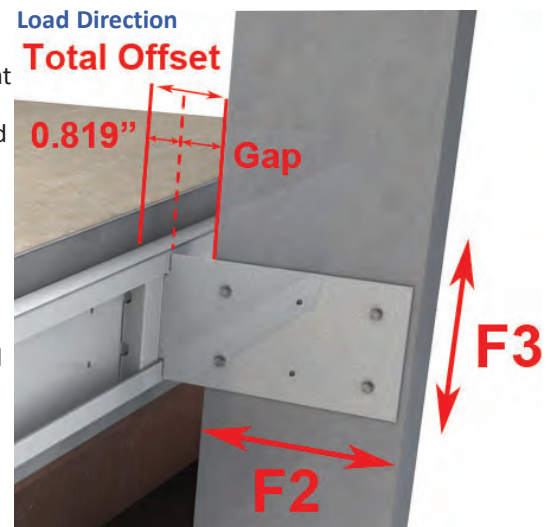

Nomenclature

DriftTrak DTLB is classified by multiplying stud depth by 100, followed by "HD," based on F2 strength required. Refer to load tables.

Example: 6" stud depth, with an outward load (F2) of 1,000 lbs

Designate: DriftTrak® DTLB600-HD

Fastener Patterns

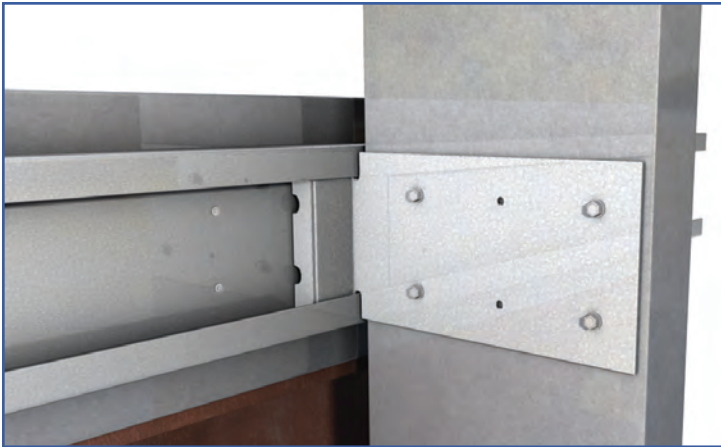

4 Hole Fastener Pattern

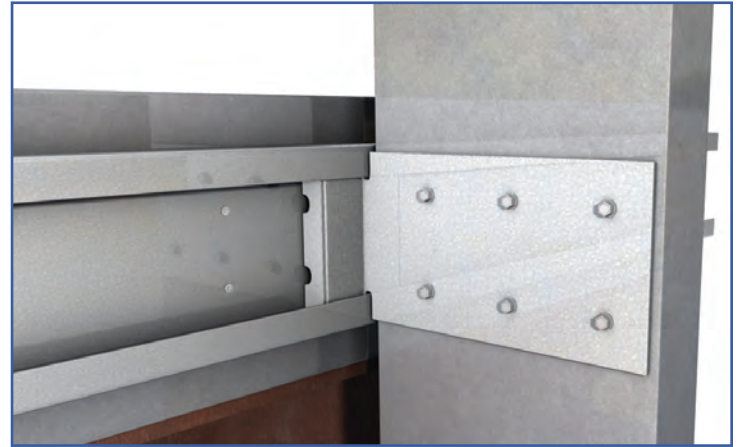

6 Hole Fastener Pattern

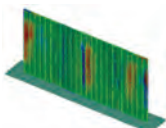
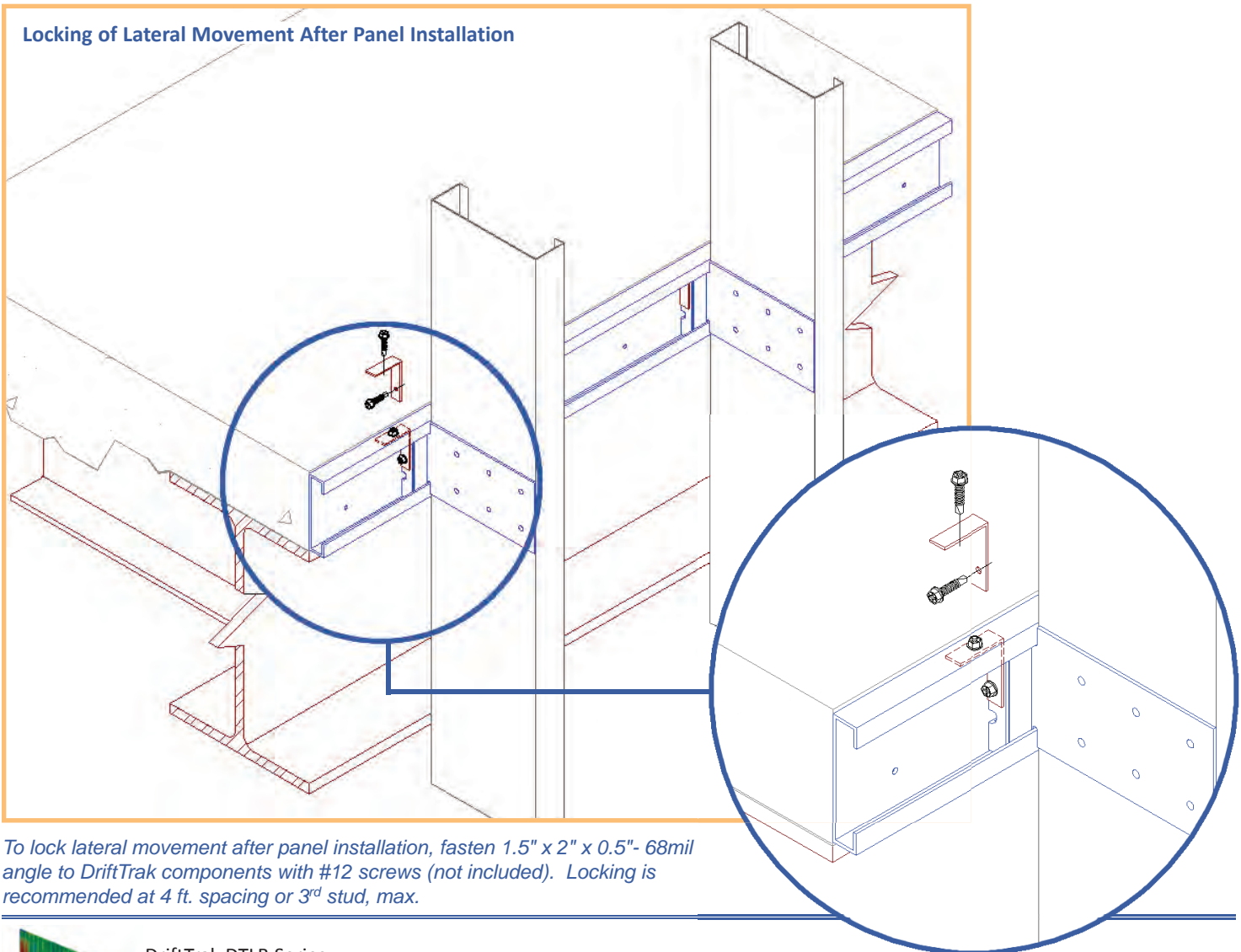

DriftTrak DTLB Series
Blast and Seismic Design Data
www.steelnetwork.com

** For more information or to review a copy of this report, please visit our website at <http://www.steelnetwork.com/Site/TechnicalData>

DriftTrak® Headed Stud

Slab Integrated Bypass

The Steel Network, Inc. 
www.steelnetwork.com
1-888-474-4876

Description

DriftTrak® Headed Stud saves the time and expense of installing DriftTrak after the concrete slab has been poured, by integrating it directly into the slab before pouring. The headed studs come preinstalled to the DriftTrak and function as the attachment to the post-tensioned slab instead of welding to the pour stop angle or use of PAF's or anchors. Once concrete is poured, the DriftTrak is ready to support exterior steel framing using any DriftTrak Bypass clip (DTSLB-HD or DTLB-HD) to accommodate vertical deflection and lateral drift requirements or provide a rigid attachment to the floor slab.

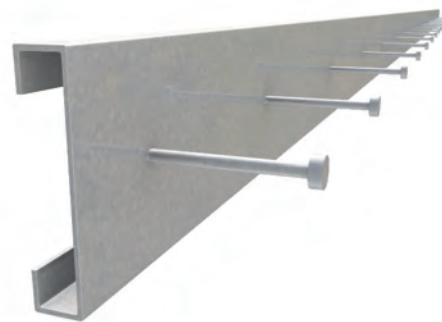

US Patent #7,503,150 & Patent Pending

Material Composition

Track Material: ASTM A1003/A1003M Structural Grade 50 (340) Type H, ST50H (ST340H): 50ksi (340MPa) minimum yield strength, 65ksi (450MPa) minimum tensile strength, 97mil minimum thickness (12 gauge, 0.1017" design thickness) with ASTM A653/A653M G60 (Z180) hot dipped galvanized coating.

Headed Stud Material: ASTM A29/A108, Grades 1010 through 1020 or equivalent, 45ksi (310MPa) minimum yield strength, 55ksi (380MPa) minimum tensile strength, 3/8" diam. x 3 1/8" length with 3/4" head diameter.

Clip Material: *DriftTrak – Headed Stud can be used with DTSLB-HD and DTLB-HD clips:* ASTM A1003/A1003M Structural Grade 50 (340) Type H, ST50H (ST340H): 50ksi (340MPa) minimum yield strength, 65ksi (450MPa) minimum tensile strength, 97mil minimum thickness (12 gauge, 0.1017" design thickness) with ASTM A653/A653M G90 (Z275) hot dipped galvanized coating.

DriftTrak Headed Stud Allowable Loads

DriftTrak® Headed Studs with DTSLB-HD, Recommended Allowable Load (lbs): F2											
DriftTrak® Headed Studs with DTLB-HD, Recommended Allowable Load (lbs): F2 & F3											
Screw Patterns with #12 Screws	F2 Load Direction						F3 Load Direction				
	DTSLB362/400-HD	DTSLB600-HD & DTSLB800-HD <i>Offset = 1.25" max</i>		DTLB362/400-HD	DTLB600-HD & DTLB800-HD		DTLB362/400-HD <i>Offset = 1" max</i>	DTLB600-HD <i>Offset = 1" max</i>		DTLB800-HD <i>Offset = 1" max</i>	
	2 Screws	2 Screws	3 Screws	4 Screws	4 Screws	6 Screws	4 Screws	4 Screws	6 Screws	4 Screws	6 Screws
33mil (20ga), 33ksi stud	376	376	564	752	752	1,128	227	258	308	226	263
33mil (20ga), 50ksi stud	544	544	816	1,088	1,088	1,632	329	373	446	326	381
43mil (18ga), 33ksi stud	560	560	840	1,120	1,120	1,657	339	384	459	336	392
43mil (18ga), 50ksi stud	810	810	1,215	1,620	1,620	1,657	490	555	664	486	567
54mil (16ga), 33ksi stud	788	788	1,182	1,576	1,576	1,657	477	540	646	473	552
54mil (16ga), 50ksi stud	1,138	1,138	1,657	1,657	1,657	1,657	688	780	933	683	797
68mil (14ga), 50ksi stud	1,554	1,554	1,657	1,657	1,657	1,657	940	1,064	1,274	932	1,088
97mil (12ga), 50ksi stud	1,554	1,554	1,657	1,657	1,657	1,657	940	1,064	1,274	932	1,088
Max Allowable Clip Load	1,657	1,657		1,657	1,657		1,163	1,908		1,272	

Notes:

- Clips are manufactured to fit into the DriftTrak PTS and provide a rigid/slip connection to the stud and allow free lateral movement of the structure.
- Design loads are for attachment of DriftTrak to stud and DriftTrak itself. Load tables reflect horizontal loads (F2) and vertical loads (F3).
- Loads listed reflect force in a single direction. When multiple loads react on the connection, it is the responsibility of the designer to check the interaction of forces.
- Allowable load tables incorporate eccentric loading of fasteners.
- Torsional effects are considered on screw group for F3 allowable loads. It is assumed that all of the torsional moment is taken by the connection to the stud.
- Allowable loads have not been increased for wind, seismic, or other factors.
- Maximum tension on a single anchor should not exceed 1,600 lbs ASD. In tension and shear, the strength of the anchor itself should be considered. The weld does not need to be considered in tension or shear as the load table and 1,600 lb ASD tension maximum are inclusive of the strength of the welds.
- Designers must check headed stud tension and shear anchorage capacity in concrete per ACI 318 based on actual headed stud edge distance and concrete compressive strength. For more information, call TSN Technical Support.
- One row of bridging is recommended at a maximum distance of 18" from DriftTrak if no other stud lateral restraint is present.
- Offset is measured from the open face of the track (slab edge) to the inside face of the stud.

Load Direction

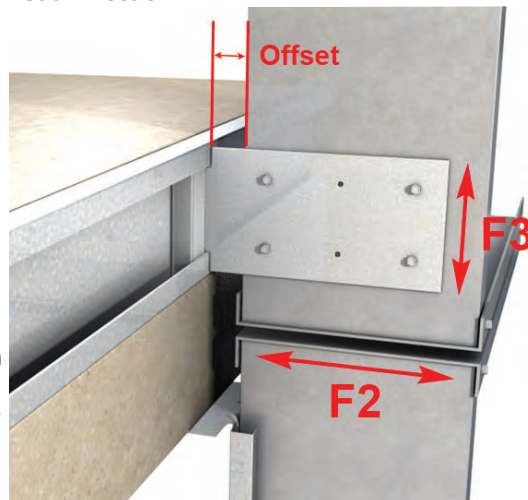

Nomenclature

DriftTrak® Headed Stud comes in 10' or 12' lengths, with headed studs in a single, centered row (See drawing on next page). To specify DriftTrak, list "DTH," followed by the length.

Example: 12 ft. length
Designate: DriftTrak® DTH – 12ft.

DriftTrak® Headed Stud: Dimensions, Layout and Stud Spacing

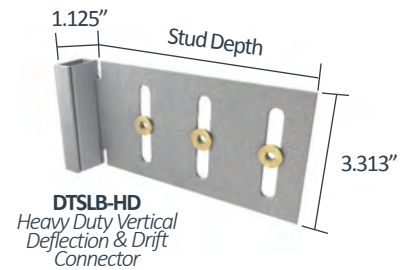
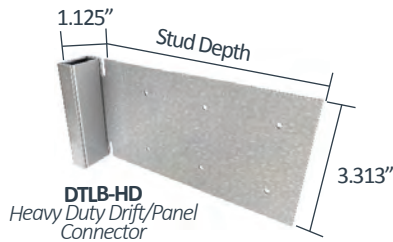
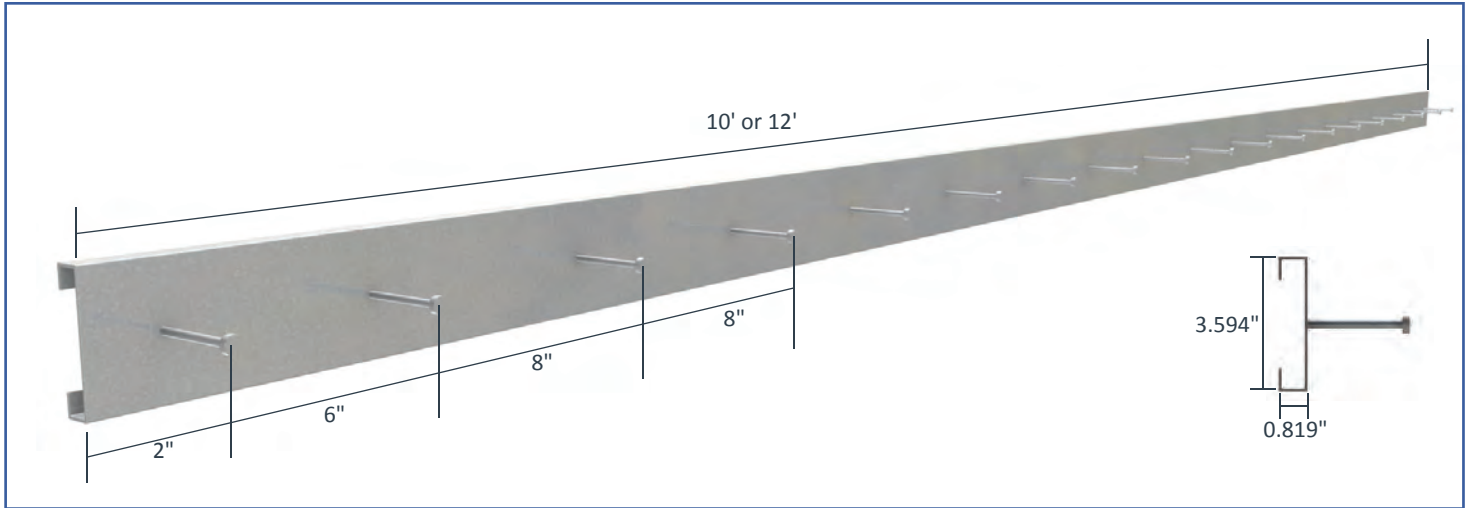

Fastener Patterns

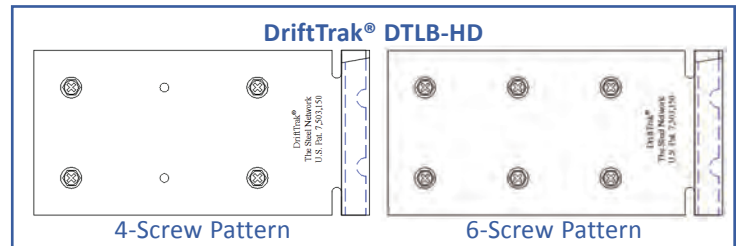
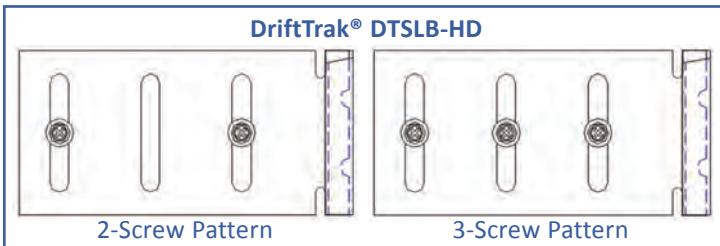

Example Details

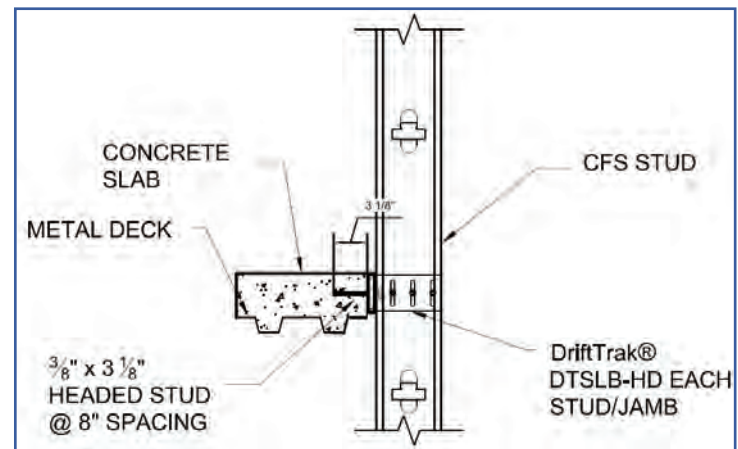
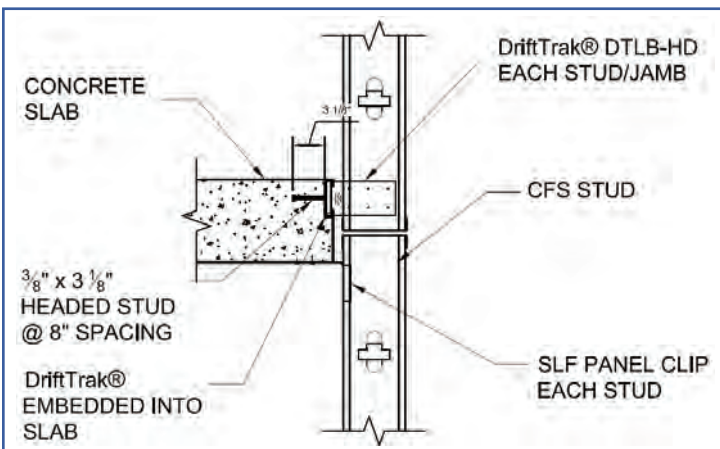

DriftTrak® Headed Stud - PTS

Slab Integrated Bypass - Post Tensioned Concrete Slabs

Description

DriftTrak® Headed Stud - PTS saves the time and expense of installing DriftTrak after the Post-Tensioned Concrete Slab (PTS) has been poured, by integrating it directly into the slab before pouring. The headed studs come preinstalled to the DriftTrak and function as the attachment to the post-tensioned slab instead of welding to the pour stop angle and use of PAF's or anchors. The DriftTrak is sized to fit above or under the high-strength tendon reinforcing at edge of slab. Once concrete is poured, the DriftTrak is ready to support exterior steel framing using any DriftTrak Bypass clip (DTSLB-PTS or DTLB-PTS) to accommodate vertical deflection and lateral drift requirements or provide a rigid attachment to the floor slab.



US Patent #7,503,150 & Patent Pending

Material Composition

Track Material: ASTM A1003/A1003M Structural Grade 50 (340) Type H, ST50H (ST340H): 50ksi (340MPa) minimum yield strength, 65ksi (450MPa) minimum tensile strength, 97mil minimum thickness (12 gauge, 0.1017" design thickness) with ASTM A653/A653M G60 (Z180) hot dipped galvanized coating.

Headed Stud Material: ASTM A29/A108, Grades 1010 through 1020 or equivalent, 45ksi (310MPa) minimum yield strength, 55ksi (380MPa) minimum tensile strength, 3/8" diam. x 3 1/8" length with 3/4" head diameter.

Clip Material: DriftTrak Headed Stud - PTS can be used with DTSLB-PTS and DTLB-PTS clips: ASTM A1003/A1003M Structural Grade 50 (340) Type H, ST50H (ST340H): 50ksi (340MPa) minimum yield strength, 65ksi (450MPa) minimum tensile strength, 97mil minimum thickness (12 gauge, 0.1017" design thickness) with ASTM A653/A653M G90 (Z275) hot dipped galvanized coating.

Track Nomenclature

DriftTrak® Headed Stud - PTS comes in 12' lengths, with headed studs in a single row (See drawing below). To specify DriftTrak, list "DTH-PTS," followed by the length.

Example: DriftTrak® DTH-PTS – 12ft.

DTLB-PTS & DTSLB-PTS

DriftTrak® Headed Studs are to be installed with DriftTrak Bypass clips DTLB-PTS and DTSLB-PTS to better facilitate panel installation while accommodating vertical deflection and lateral drift requirements in floor slab bypass conditions. DriftTrak Connectors are sold separately.

Connector Nomenclature

DriftTrak DTLB-PTS & DTSLB-PTS are made for 6" & 8" studs. They are classified by multiplying stud depth by 100, followed by "PTS," then "-L" for a Left version or "-R" for a Right version.

Example: Vertical Deflection required, left version required for installation with 6" stud

Designate: DriftTrak® DTSLB600-PTS-L

* Clips shown are left versions of DriftTrak DTLB-PTS & DTSLB-PTS. Right side versions are available for order as standard parts.

** Clips and track sold separately.

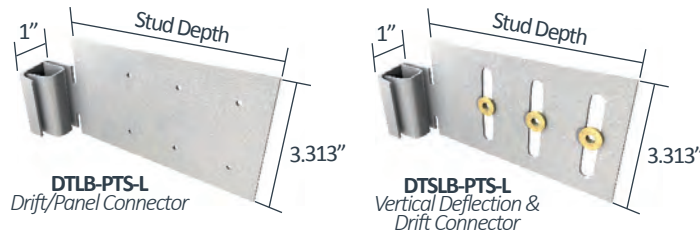

DriftTrak® Headed Stud - PTS: Dimensions, Layout and Stud Spacing

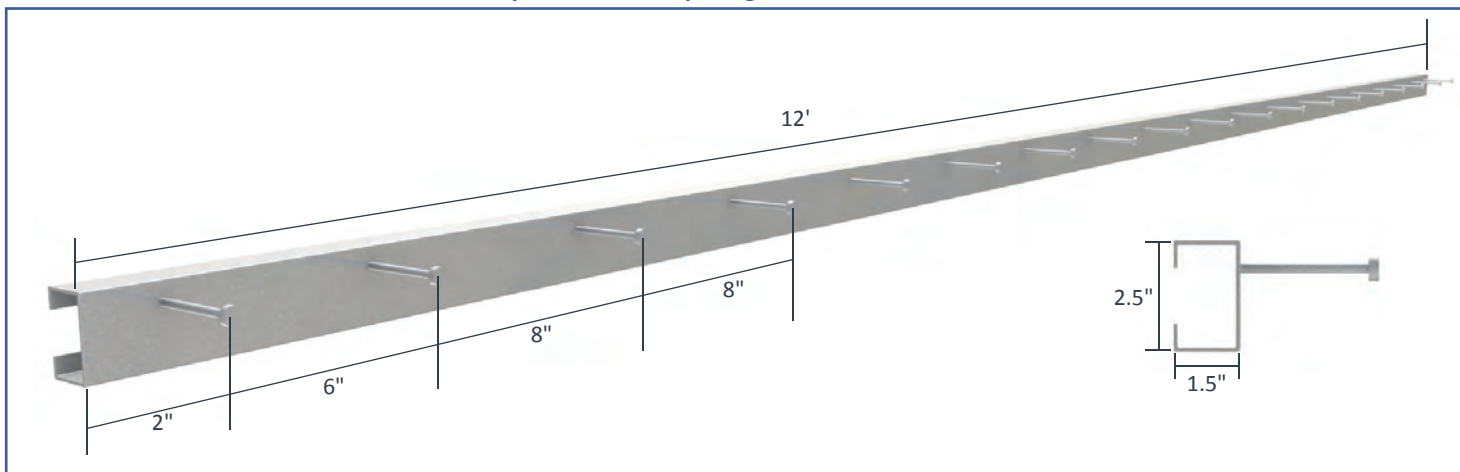

DriftTrak Headed Stud - PTS Allowable Loads

Screw Patterns with #12 Screws	F2 Direction						F3 Direction				
	DTSLB600-PTS & DTSLB800-PTS			DTLB600-PTS		DTLB800-PTS		DTLB600-PTS <i>Offset = 1.875" max</i>		DTLB800-PTS <i>Offset = 2.5" max</i>	
	2 Screws	3 Screws	4 Screws	6 Screws	4 Screws	6 Screws	4 Screws	6 Screws	4 Screws	6 Screws	
33mil (20ga), 33ksi stud	377	565	754	1,130	754	1,110	256	313	250	294	
33mil (20ga), 50ksi stud	544	817	1,089	1,136	1,089	1,110	370	452	361	425	
43mil (18ga), 33ksi stud	561	841	1,122	1,136	1,110	1,110	381	465	372	438	
43mil (18ga), 50ksi stud	810	1,080	1,136	1,136	1,110	1,110	551	672	538	633	
54mil (16ga), 33ksi stud	789	1,080	1,136	1,136	1,110	1,110	536	655	523	616	
54mil (16ga), 50ksi stud	1,080	1,080	1,136	1,136	1,110	1,110	775	945	756	890	
68mil (14ga), 50ksi stud	1,080	1,080	1,136	1,136	1,110	1,110	1,064	1,064	1,000	1,000	
97mil (12ga), 50ksi stud	1,080	1,080	1,136	1,136	1,110	1,110	1,064	1,064	1,000	1,000	
Max Allowable Clip Load	1,080		1,136		1,110		1,064		1,000		

Notes:

- Maximum tension on a single anchor should not exceed 1,600 lbs ASD. In tension and shear, the strength of the anchor itself should be considered. The weld does not need to be considered in tension or shear as the load table and 1,600 lb ASD tension maximum are inclusive of the strength of the welds. Designers must check headed stud tension and shear anchorage capacity in concrete per ACI 318 based on actual headed stud edge distance and concrete compressive strength. For more information, call TSN Technical Support at 1-888-474-4TSN.
- Allowable load tables incorporate eccentric loading of fasteners.
- Loads listed reflect force in a single direction. When multiple loads react on the connection, it is the responsibility of the designer to check the interaction of forces.
- Torsional effects are considered on screw group for F3 allowable loads. It is assumed that all of the torsional moment is taken by the connection to the stud.
- Design loads are for attachment of DriftTrak to stud and DriftTrak itself. Load tables reflect horizontal loads (F2) and vertical loads (F3)
- Allowable loads have not been increased for wind, seismic, or other factors.
- Clips are manufactured to fit into the DriftTrak and provide a rigid/slip connection to the stud, and free lateral movement of the structure.
- One row of bridging is recommended at a maximum distance of 18" from DriftTrak if no other stud lateral restraint is present.

Load Direction

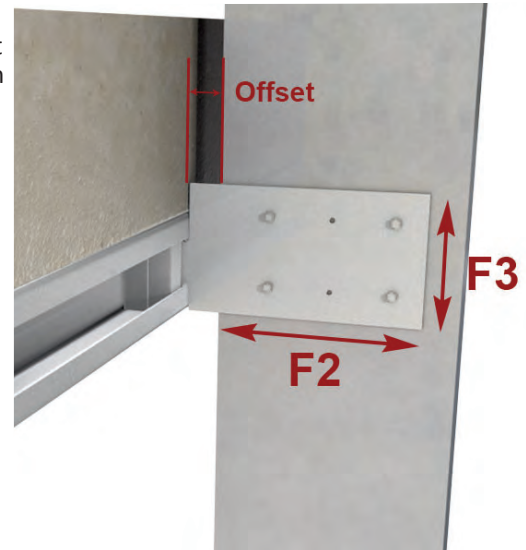

Fastener Patterns

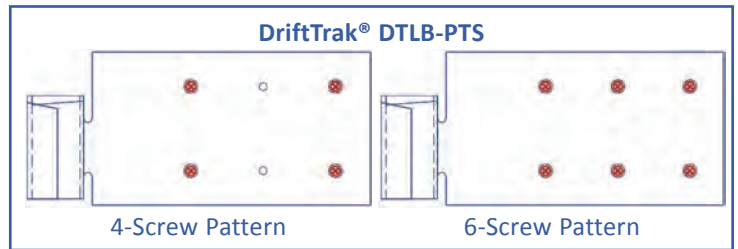
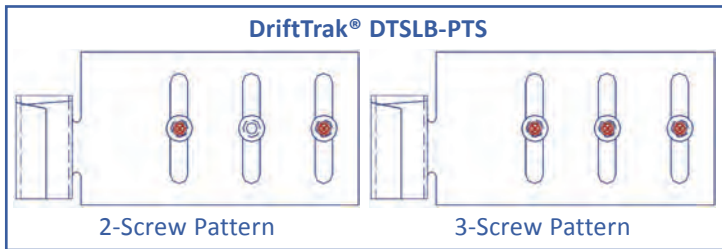

Example Details

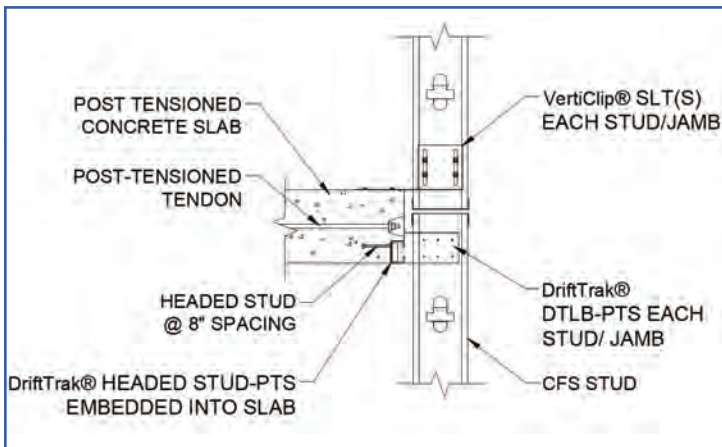

**DriftTrak® DTLB-PTS with Headed Studs:
Attachment to Post-Tensioned Concrete Slab**

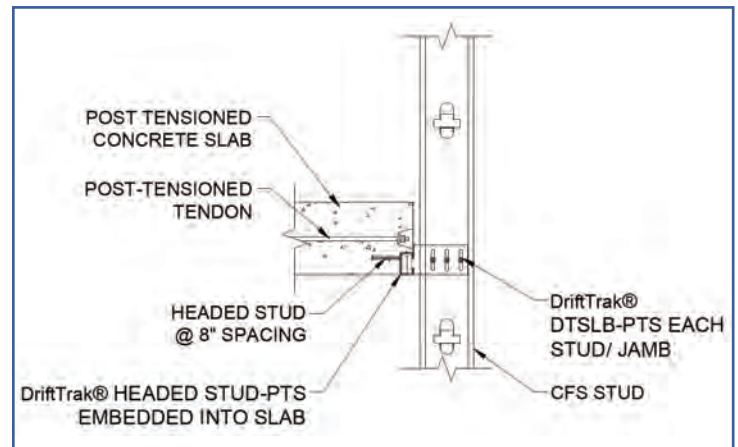

**DriftTrak® DTSLB-PTS with Headed Studs:
Attachment to Post-Tensioned Concrete Slab**

BRIDGING THE GAP Between Quality & Speed

with **TSN's** Bridging Connections & Members

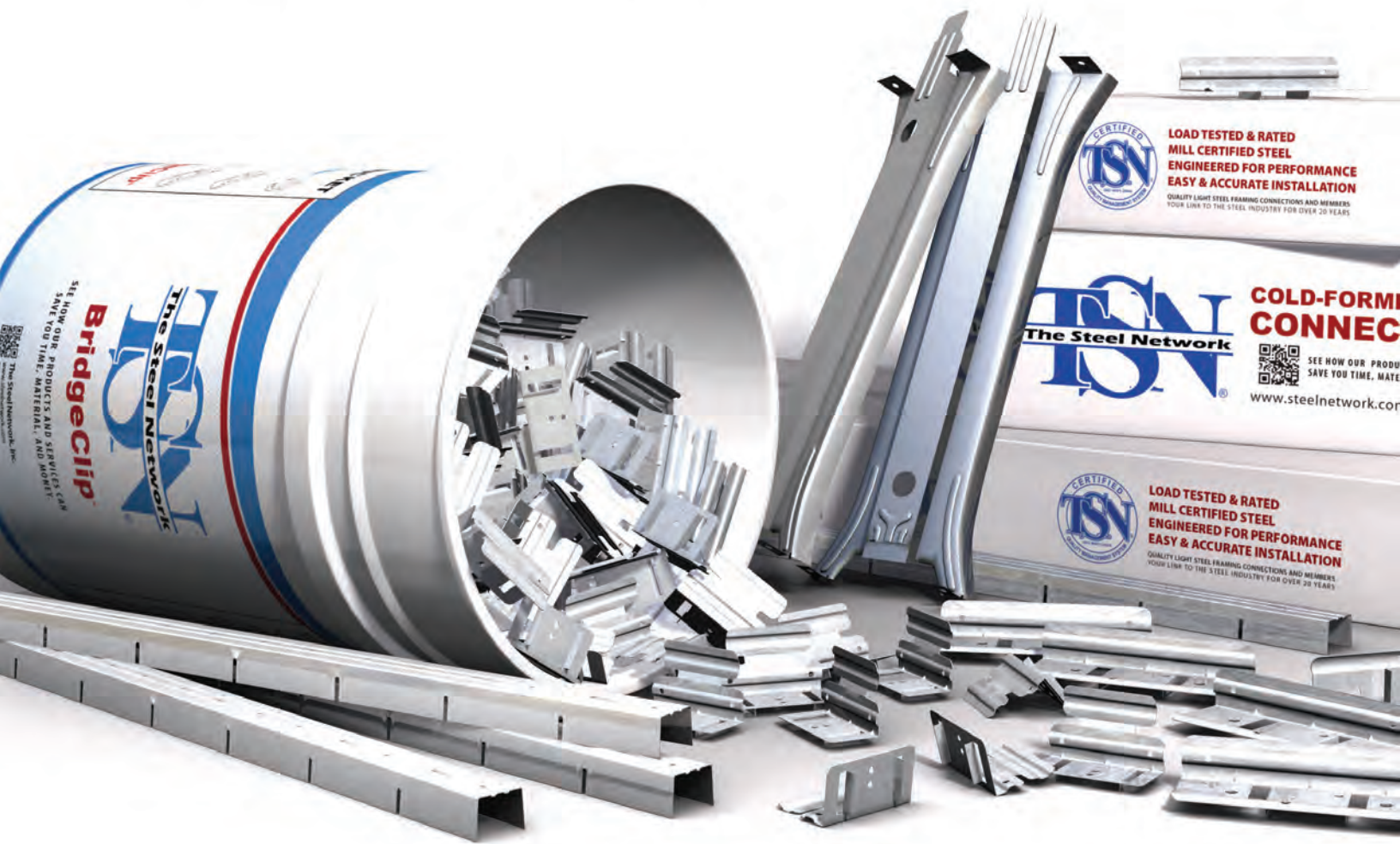

Just one of TSN's complete line of quality, **load tested & rated light steel framing connections & members.**

Quick Installation · Long Term Performance · It's What's Inside That Counts



(888) 474-4876

www.steelnetwork.com

Manufacturing Quality Connections & Members for Over 20 Years



© 2016 The Steel Network, Inc. All rights reserved. BridgeClip®, BridgeBar® and BuckleBridge® are a registered trademarks of The Steel Network, Inc.

Wall Bridging

Background

Bridging Background

Bridging for load bearing and curtain wall studs is needed to resist the following forces:

- 1 - Weak axis buckling induced by axial compression load.
- 2 - Torsion induced by wind load.

As axial compression and lateral wind loads are applied, wall studs react with weak axis buckling and torsional rotation. To offset these forces, a form of bridging is incorporated into the wall system. Bridging loads accumulate over the run of the wall, requiring transfer of lateral forces in bridging at columns or to the floor slab into the structural load path to the foundation.

AISI Wall Stud Design Standard (S211) and AISI Specification (S100) provide the load and stiffness requirements for bracing members due to the effects of axial compression load and wind load as given in the table below. Contact TSN Technical Support if further information is needed regarding wall bridging design.

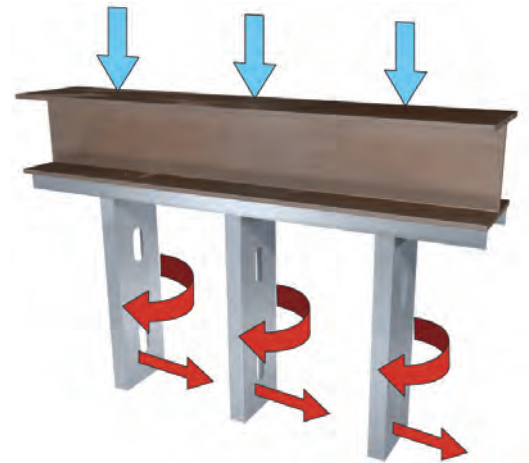

Bridging Requirements

	AISI Wall Stud Design Standard (S211)	AISI Specification (S100)
Stud Axial Compression	Load Capacity: Bracing Load $P_{\text{Brace}}^* = 0.02 \times \text{Stud Compression Load } (P_{\text{Stud}}) \times \# \text{ of studs braced.}$	Load Capacity: Bracing Load $P_{\text{Brace}}^* = 0.01 \times \text{Stud Compression Load } (P_{\text{Stud}}) \times \# \text{ of studs braced.}$
		Stiffness Capacity: Lateral Stiffness $\beta_{\text{Brace}} = 4 \times \text{Stud Nominal Axial Strength} / \text{Unbraced Length}$ (for one row of bridging). Lateral Stiffness $\beta_{\text{Brace}} = 6 \times \text{Stud Nominal Axial Strength} / \text{Unbraced Length}$ (for two rows of bridging).
Wind	Load Capacity: Twist Load $P_L = 1.5 \times \text{Wind Load} \times \text{Bridging Spacing} \times \text{Stud Spacing} \times m(\text{Shear Center Distance}) / \text{Stud Depth.}$ Twist Moment $M_1 = P_L \times \text{Stud Depth.}$	

* Bracing forces accumulate over the run of the wall until anchored.

Bridging Load Bearing Studs Against Torsion By Wind

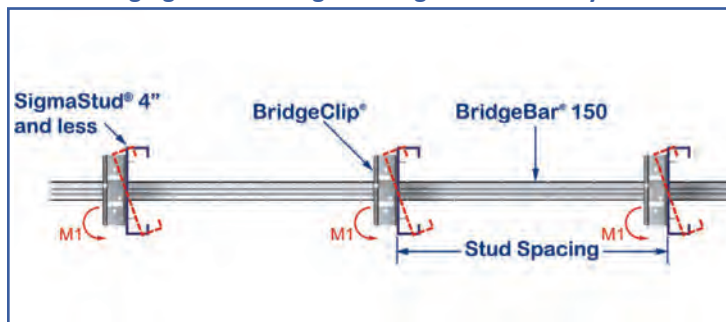

Bridging Load Bearing Studs Against Weak Axis Buckling

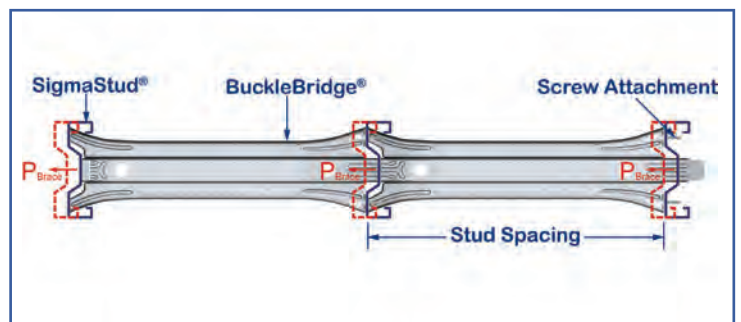
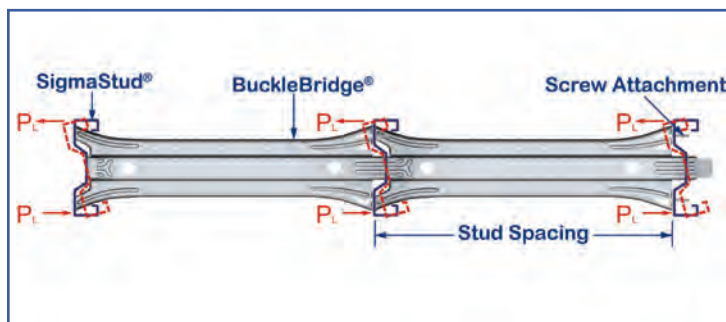
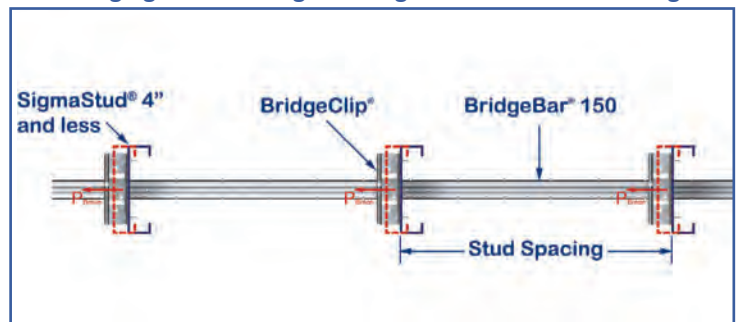

Curtain Wall Bridging Chart

Quick Reference

Bridging Clip Chart: Design Wind Pressure, Stud Spacing and Maximum Bridging Spacing															
Section	10 psf			20 psf						25 psf					
	24" o.c.			16" o.c.			24" o.c.			16" o.c.			24" o.c.		
	5'	6'	7'	5'	6'	7'	5'	6'	7'	5'	6'	7'	5'	6'	7'
600S162-33, 33 ksi	BC-33, 1	BC-33, 1	BC-33, 1	BC-33, 1	BC-33, 1	BC-33, 1	BC-33, 1	BC-33, 1	BC-33, 1	BC-33, 1	BC-33, 1	BC-33, 1	BC-33, 1	BC-33, 1	N/A
600S162-43, 33 ksi	BC-33, 1	BC-33, 1	BC-33, 1	BC-33, 1	BC-33, 1	BC-33, 1	BC-33, 1	BC-33, 1	BC-33, 1	BC-33, 1	BC-33, 1	BC-33, 1	BC-33, 1	BC-33, 1	BC-33, 1
600S162-54, 50 ksi	BC-33, 1	BC-33, 1	BC-33, 1	BC-33, 1	BC-33, 1	BC-33, 1	BC-33, 1	BC-33, 1	BC-33, 1	BC-33, 1	BC-33, 1	BC-33, 1	BC-33, 1	BC-33, 1	BC-33, 1
600S162-68, 50 ksi	BC-33, 1	BC-33, 1	BC-33, 1	BC-33, 1	BC-33, 1	BC-33, 1	BC-33, 1	BC-33, 1	BC-33, 1	BC-33, 1	BC-33, 1	BC-33, 1	BC-33, 1	BC-33, 1	BC-33, 1
600S162-97, 50 ksi	BC-33, 1	BC-33, 1	BC-33, 1	BC-33, 1	BC-33, 1	BC-33, 1	BC-33, 1	BC-33, 1	BC-33, 1	BC-33, 1	BC-33, 1	BC-33, 1	BC-33, 1	BC-33, 1	BC-33, 1
600S200-33, 33 ksi	BC-33, 1	BC-33, 1	BC-33, 1	BC-33, 1	BC-33, 1	BC-33, 1	BC-33, 1	BC-33, 3	BC-33, 3	BC-33, 1	BC-33, 1	BC-33, 1	BC-33, 3	BC-43, 3	BC-43, 3
600S200-43, 33 ksi	BC-33, 1	BC-33, 1	BC-33, 1	BC-33, 1	BC-33, 1	BC-33, 1	BC-33, 1	BC-33, 1	BC-33, 1	BC-33, 1	BC-33, 1	BC-33, 1	BC-33, 1	BC-33, 1	BC-43, 1
600S200-54, 50 ksi	BC-33, 1	BC-33, 1	BC-33, 1	BC-33, 1	BC-33, 1	BC-33, 1	BC-33, 1	BC-33, 1	BC-33, 1	BC-33, 1	BC-33, 1	BC-33, 1	BC-33, 1	BC-33, 1	BC-33, 3
600S200-68, 50 ksi	BC-33, 1	BC-33, 1	BC-33, 1	BC-33, 1	BC-33, 1	BC-33, 1	BC-33, 1	BC-33, 1	BC-33, 1	BC-33, 1	BC-33, 1	BC-33, 1	BC-33, 1	BC-33, 1	BC-33, 1
600S200-97, 50 ksi	BC-33, 1	BC-33, 1	BC-33, 1	BC-33, 1	BC-33, 1	BC-33, 1	BC-33, 1	BC-33, 1	BC-33, 1	BC-33, 1	BC-33, 1	BC-33, 1	BC-33, 1	BC-33, 1	BC-33, 1
800S162-33, 33 ksi	BC-33, 1	BC-33, 1	BC-33, 1	BC-33, 1	BC-33, 1	BC-33, 1	BC-33, 1	BC-33, 1	BC-43, 1	BC-33, 1	BC-33, 1	BC-33, 1	BC-33, 1	BC-43, 1	BC-43, 1
800S162-43, 33 ksi	BC-33, 1	BC-33, 1	BC-33, 1	BC-33, 1	BC-33, 1	BC-33, 1	BC-33, 1	BC-33, 1	BC-33, 1	BC-33, 1	BC-33, 1	BC-33, 1	BC-33, 1	BC-33, 1	BC-43, 1
800S162-54, 50 ksi	BC-33, 1	BC-33, 1	BC-33, 1	BC-33, 1	BC-33, 1	BC-33, 1	BC-33, 1	BC-33, 1	BC-33, 1	BC-33, 1	BC-33, 1	BC-33, 1	BC-33, 1	BC-33, 1	BC-33, 1
800S162-68, 50 ksi	BC800	BC800	BC800	BC800	BC800	BC800	BC800	BC800	BC800	BC800	BC800	BC800	BC800	BC800	BC800
800S162-97, 50 ksi	BC800	BC800	BC800	BC800	BC800	BC800	BC800	BC800	BC800	BC800	BC800	BC800	BC800	BC800	BC800
800S200-33, 33 ksi	BC-33, 1	BC-33, 1	BC-33, 1	BC-33, 1	BC-33, 1	BC-33, 1	BC-43, 1	BC-43, 1	BC-33, 3	BC-33, 1	BC-43, 1	BC-43, 1	BC-43, 1	BC-33, 3	BC-43, 3
800S200-43, 33 ksi	BC-33, 1	BC-33, 1	BC-33, 1	BC-33, 1	BC-33, 1	BC-33, 1	BC-33, 1	BC-33, 1	BC-43, 1	BC-33, 1	BC-33, 1	BC-33, 1	BC-43, 1	BC-43, 1	BC-33, 3
800S200-54, 50 ksi	BC-33, 1	BC-33, 1	BC-33, 1	BC-33, 1	BC-33, 1	BC-33, 1	BC-33, 1	BC-33, 1	BC-33, 1	BC-33, 1	BC-33, 1	BC-33, 1	BC-33, 1	BC-43, 1	BC-43, 1
800S200-68, 50 ksi	BC800	BC800	BC800	BC800	BC800	BC800	BC800	BC800	BC800	BC800	BC800	BC800	BC800	BC800	BC800
800S200-97, 50 ksi	BC800	BC800	BC800	BC800	BC800	BC800	BC800	BC800	BC800	BC800	BC800	BC800	BC800	BC800	BC800

Bridging Clip Chart: Design Wind Pressure, Stud Spacing and Maximum Bridging Spacing															
Section	30 psf						40 psf						50 psf		
	16" o.c.			24" o.c.			16" o.c.			24" o.c.			16" o.c.		
	5'	6'	7'	5'	6'	7'	5'	6'	7'	5'	6'	7'	5'	6'	7'
600S162-33, 33 ksi	BC-33, 1	BC-33, 1	BC-33, 1	BC-33, 1	BC-33, 3	N/A	BC-33, 1	BC-33, 3	N/A	BC-43, 3	N/A	N/A	BC-33, 3	BC-43, 3	N/A
600S162-43, 33 ksi	BC-33, 1	BC-33, 1	BC-33, 1	BC-33, 1	BC-33, 1	N/A	BC-33, 1	BC-33, 1	BC-33, 1	BC-33, 1	BC-43, 1	N/A	BC-33, 1	BC-33, 1	N/A
600S162-54, 50 ksi	BC-33, 1	BC-33, 1	BC-33, 1	BC-33, 1	BC-33, 1	BC-33, 1	BC-33, 1	BC-33, 1	BC-33, 1	BC-33, 1	BC-43, 1	N/A	BC-33, 1	BC-33, 1	BC-33, 3
600S162-68, 50 ksi	BC-33, 1	BC-33, 1	BC-33, 1	BC-33, 1	BC-33, 1	BC-33, 1	BC-33, 1	BC-33, 1	BC-33, 1	BC-33, 1	BC-33, 1	BC-43, 1	BC-33, 1	BC-33, 1	BC-33, 1
600S162-97, 50 ksi	BC-33, 1	BC-33, 1	BC-33, 1	BC-33, 1	BC-33, 1	BC-33, 1	BC-33, 1	BC-33, 1	BC-33, 1	BC-33, 1	BC-33, 1	BC-33, 1	BC-33, 1	BC-33, 1	BC-33, 1
600S200-33, 33 ksi	BC-33, 1	BC-33, 3	BC-33, 3	BC-43, 3	BC-43, 3	N/A	BC-33, 3	BC-43, 3	BC-43, 3	BC600	BC600	N/A	BC-43, 3	BC-43, 3	N/A
600S200-43, 33 ksi	BC-33, 1	BC-33, 1	BC-33, 1	BC-33, 1	BC-43, 1	BC-43, 1	BC-33, 1	BC-43, 1	BC-43, 1	BC-43, 1	BC600	N/A	BC-43, 1	BC-43, 1	BC-43, 3
600S200-54, 50 ksi	BC-33, 1	BC-33, 1	BC-33, 1	BC-33, 1	BC-43, 1	BC-43, 3	BC-33, 1	BC-33, 1	BC-43, 1	BC-43, 1	BC600	BC600	BC-33, 3	BC-43, 1	BC600
600S200-68, 50 ksi	BC-33, 1	BC-33, 1	BC-33, 1	BC-33, 1	BC-33, 1	BC-43, 1	BC-33, 1	BC-33, 1	BC-33, 1	BC-33, 3	BC-43, 3	BC600	BC-33, 1	BC-33, 3	BC-43, 1
600S200-97, 50 ksi	BC-33, 1	BC-33, 1	BC-33, 1	BC-33, 1	BC-33, 1	BC-33, 1	BC-33, 1	BC-33, 1	BC-33, 1	BC-33, 1	BC-33, 1	BC-43, 1	BC-33, 1	BC-33, 1	BC-33, 1
800S162-33, 33 ksi	BC-33, 1	BC-33, 1	BC-43, 1	BC-43, 1	BC-33, 3	N/A	BC-43, 1	BC-43, 1	BC-33, 3	BC-33, 3	BC-43, 3	N/A	BC-43, 1	BC-33, 3	N/A
800S162-43, 33 ksi	BC-33, 1	BC-33, 1	BC-33, 1	BC-33, 1	BC-43, 1	BC-43, 1	BC-33, 1	BC-33, 1	BC-43, 1	BC-43, 1	BC-33, 3	N/A	BC-43, 1	BC-43, 1	BC-33, 3
800S162-54, 50 ksi	BC-33, 1	BC-33, 1	BC-33, 1	BC-33, 1	BC-33, 1	BC-43, 1	BC-33, 1	BC-33, 1	BC-33, 1	BC-33, 1	BC-43, 1	BC-33, 3	BC-33, 1	BC-33, 1	BC-43, 1
800S162-68, 50 ksi	BC800	BC800	BC800	BC800	BC800	BC800	BC800	BC800	BC800	BC800	BC800	BC800	BC800	BC800	BC800
800S162-97, 50 ksi	BC800	BC800	BC800	BC800	BC800	BC800	BC800	BC800	BC800	BC800	BC800	BC800	BC800	BC800	BC800
800S200-33, 33 ksi	BC-43, 1	BC-43, 1	BC-33, 3	BC-33, 3	BC-43, 3	BC800	BC-33, 3	BC-33, 3	BC-43, 3	BC800	BC800	BC800	BC-43, 3	BC800	BC800
800S200-43, 33 ksi	BC-33, 1	BC-33, 1	BC-43, 1	BC-43, 1	BC-33, 3	BC-43, 3	BC-43, 1	BC-33, 3	BC-33, 3	BC-43, 3	BC800	BC800	BC-33, 3	BC-43, 3	BC800
800S200-54, 50 ksi	BC-33, 1	BC-33, 1	BC-33, 1	BC-43, 1	BC-43, 1	BC-33, 3	BC-33, 1	BC-43, 1	BC-43, 1	BC-33, 3	BC-43, 3	BC800	BC-43, 1	BC-33, 3	BC-43, 3
800S200-68, 50 ksi	BC800	BC800	BC800	BC800	BC800	BC800	BC800	BC800	BC800	BC800	BC800	BC800	BC800	BC800	BC800
800S200-97, 50 ksi	BC800	BC800	BC800	BC800	BC800	BC800	BC800	BC800	BC800	BC800	BC800	BC800	BC800	BC800	BC800

****Important table notes on next page.**

BuckleBridge® Bridging Chart: Design Wind Pressure and Maximum Bridging Spacing															
Section	20 psf			25 psf			30 psf			40 psf			50 psf		
	5'	6'	7'	5'	6'	7'	5'	6'	7'	5'	6'	7'	5'	6'	7'
600S162-33, 33 ksi	BKB	BKB	BKB	BKB	BKB	BKB	BKB	BKB	BKB	BKB	BKB	N/A	BKB	BKB	N/A
600S162-43, 33 ksi	BKB	BKB	BKB	BKB	BKB	BKB	BKB	BKB	BKB	BKB	BKB	BKB	BKB	BKB	N/A
600S162-54, 50 ksi	BKB	BKB	BKB	BKB	BKB	BKB	BKB	BKB	BKB	BKB	BKB	BKB	BKB	BKB	BKB
600S162-68, 50 ksi	BKB	BKB	BKB	BKB	BKB	BKB	BKB	BKB	BKB	BKB	BKB	BKB	BKB	BKB	BKB
600S162-97, 50 ksi	BKB	BKB	BKB	BKB	BKB	BKB	BKB	BKB	BKB	BKB	BKB	BKB	BKB	BKB	BKB
600S200-33, 33 ksi	BKB	BKB	BKB	BKB	BKB	BKB	BKB	BKB	BKB	BKB	BKB	BKB	BKB	BKB	N/A
600S200-43, 33 ksi	BKB	BKB	BKB	BKB	BKB	BKB	BKB	BKB	BKB	BKB	BKB	BKB	BKB	BKB	BKB
600S200-54, 50 ksi	BKB	BKB	BKB	BKB	BKB	BKB	BKB	BKB	BKB	BKB	BKB	BKB	BKB	BKB	BKB
600S200-68, 50 ksi	BKB	BKB	BKB	BKB	BKB	BKB	BKB	BKB	BKB	BKB	BKB	BKB	BKB	BKB	BKB
600S200-97, 50 ksi	BKB	BKB	BKB	BKB	BKB	BKB	BKB	BKB	BKB	BKB	BKB	BKB	BKB	BKB	BKB
800S162-33, 33 ksi	BKB	BKB	BKB	BKB	BKB	BKB	BKB	BKB	BKB	BKB	BKB	BKB	BKB	BKB	N/A
800S162-43, 33 ksi	BKB	BKB	BKB	BKB	BKB	BKB	BKB	BKB	BKB	BKB	BKB	BKB	BKB	BKB	BKB
800S162-54, 50 ksi	BKB	BKB	BKB	BKB	BKB	BKB	BKB	BKB	BKB	BKB	BKB	BKB	BKB	BKB	BKB
800S162-68, 50 ksi	BKB	BKB	BKB	BKB	BKB	BKB	BKB	BKB	BKB	BKB	BKB	BKB	BKB	BKB	BKB
800S162-97, 50 ksi	BKB	BKB	BKB	BKB	BKB	BKB	BKB	BKB	BKB	BKB	BKB	BKB	BKB	BKB	BKB
800S200-33, 33 ksi	BKB	BKB	BKB	BKB	BKB	BKB	BKB	BKB	BKB	BKB	BKB	BKB	BKB	BKB	BKB
800S200-43, 33 ksi	BKB	BKB	BKB	BKB	BKB	BKB	BKB	BKB	BKB	BKB	BKB	BKB	BKB	BKB	BKB
800S200-54, 50 ksi	BKB	BKB	BKB	BKB	BKB	BKB	BKB	BKB	BKB	BKB	BKB	BKB	BKB	BKB	BKB
800S200-68, 50 ksi	BKB	BKB	BKB	BKB	BKB	BKB	BKB	BKB	BKB	BKB	BKB	BKB	BKB	BKB	BKB
800S200-97, 50 ksi	BKB	BKB	BKB	BKB	BKB	BKB	BKB	BKB	BKB	BKB	BKB	BKB	BKB	BKB	BKB

Notes:

- Listed wind pressures represent calculated design wind pressure (0.6W based on 2015 IBC).
- Allowable pressures are limited by published test data allowable torsional moments for bridging elements.
- Torsional moment acting on bridging elements is calculated as:

$$M = 1.5 \times \text{Wind Pressure} \times \text{Bridging Spacing} \times \text{Stud Spacing} \times m \text{ (distance from stud web to shear center).}$$

- Wall height is assumed twice the bridging spacing.
- BuckleBridge® stud spacing is fixed at 16".
- Stud design is limited by its flexural strength calculated with torsional bracing assumed at the bridging spacing and $k_b = 0$ and deflection limit of $L/360$.
- 20 psf and higher wind pressures have been multiplied by 0.7 for deflection determination, in accordance with footnote "f" of IBC table 1604.3. The 10 psf pressure has not been reduced for deflection checks.

Nomenclature:

- **BC-33, 1** - BridgeClip BC-33 with (1) #10 screw fastener into bridging member.
- **BC-33, 3** - BridgeClip BC-33 with (1) #10 screw fastener into bridging member and (2) #10 screw fasteners into the web of the stud.
- **BC-43, 1** - BridgeClip BC-43 with (1) #10 screw fastener into bridging member.
- **BC-43, 3** - BridgeClip BC-43 with (1) #10 screw fastener into bridging member and (2) #10 screw fasteners into the web of the stud.
- **BC600** - BridgeClip BC600 with (2) #10 screw fasteners into bridging member and (2) #10 screw fasteners into the web of the stud.
- **BC800** - BridgeClip BC800 with (2) #10 screw fasteners into bridging member and (2) #10 screw fasteners into the web of the stud.
- **BKB** - BuckleBridge with (1) #10 screw on alternate sides of the BuckleBridge at 3rd stud (48" o.c.) Use (2) #10 screws at end of wall run.

Wall Bridging Anchorage

Quick Reference

Anchorage of Lateral Bracing (Bridging) Forces

Load Bearing Wall Bridging Row Anchored to Jamb Stud or End Column - Track Bracing Utilizing BridgeBar® 150 with BC600/BC800

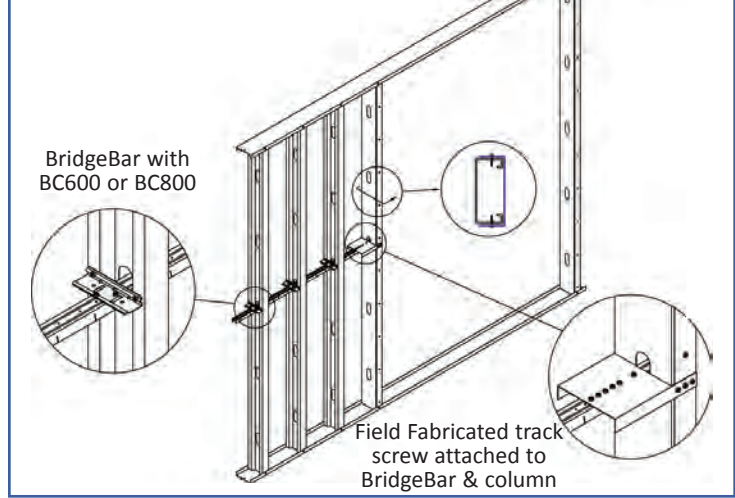

Load Bearing Wall Bridging Row Anchored to Jamb Stud or End Column - Track Bracing Utilizing BuckleBridge®

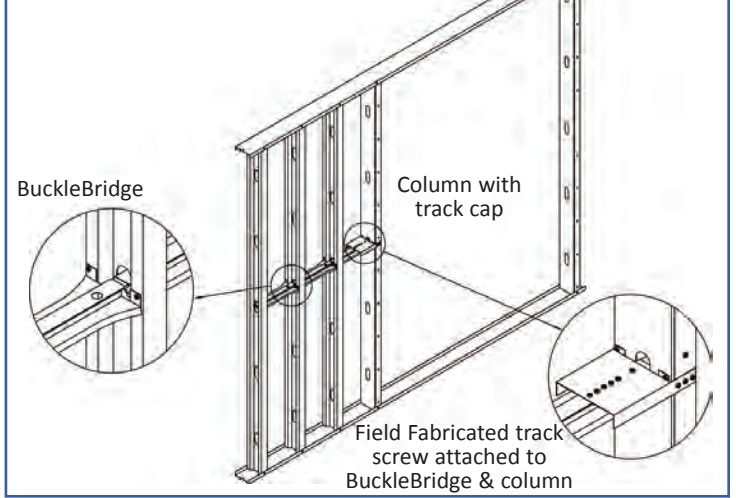

Load Bearing Wall Bridging Row Anchored to Floor System Through Cross Bracing - Utilizing BuckleBridge

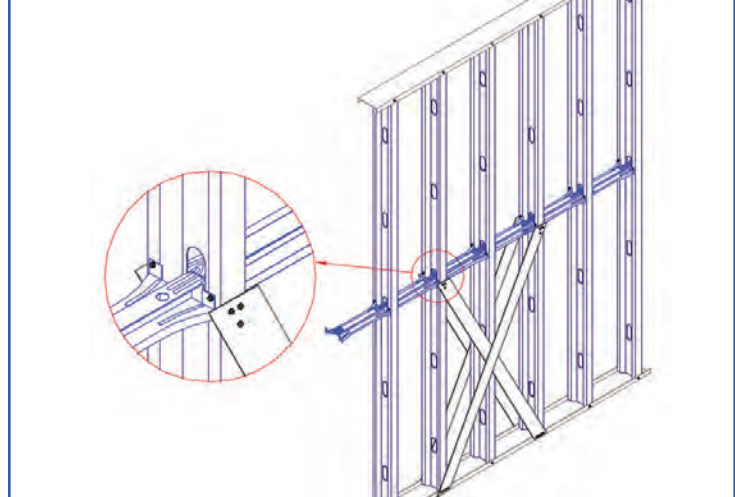

Load Bearing Wall Bridging Row Anchored to Floor System Through Cross Bracing - Utilizing BridgeBar 150 with BC600/BC800

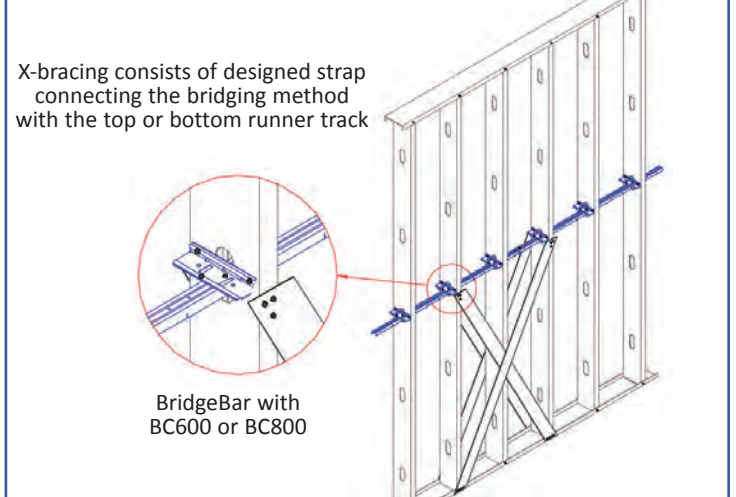

Load Bearing Wall Bridging Row Anchored to Jamb Stud or End Column - Flat Strap Bracing w/ Blocking

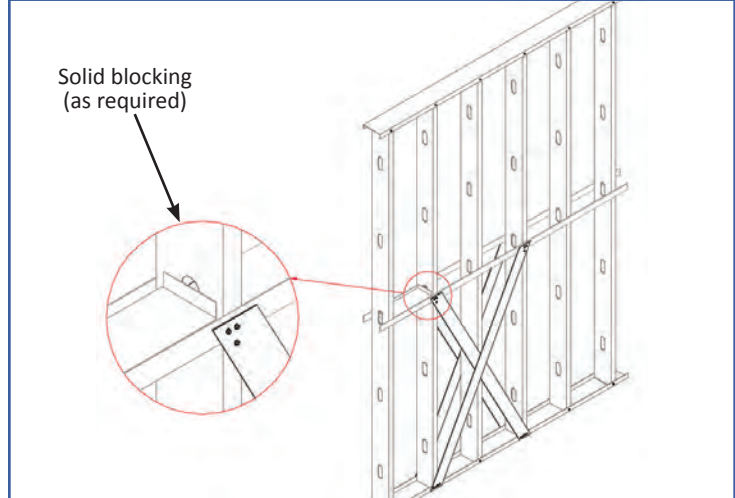

Load Bearing Wall Bridging Row Anchored to Jamb Stud or End Column - Flat Strap Bracing w/ Blocking

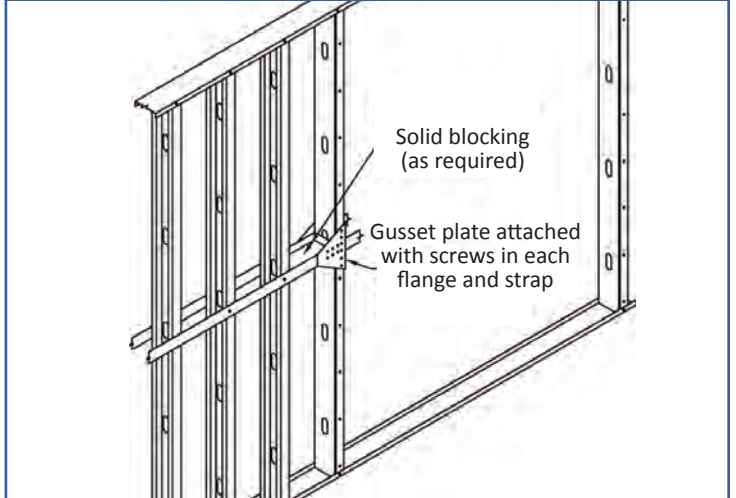

BridgeClip®

Secures Channel to Stud

Material Composition

BC-33: ASTM A1003/A1003M Structural Grade 50 (340) Type H, ST50H (ST340H): 50ksi (340MPa) minimum yield strength, 65ksi (450MPa) minimum tensile strength, 33mil minimum thickness (20 gauge, 0.0346" design thickness) with ASTM A653/A653M G90 (Z275) hot dipped galvanized coating.

BC-43, BC600 & BC800: ASTM A1003/A1003M Structural Grade 50 (340) Type H, ST50H (ST340H): 50ksi (340MPa) minimum yield strength, 65ksi (450MPa) minimum tensile strength, 43mil minimum thickness (18 gauge, 0.0451" design thickness) with ASTM A653/A653M G90 (Z275) hot dipped galvanized coating.

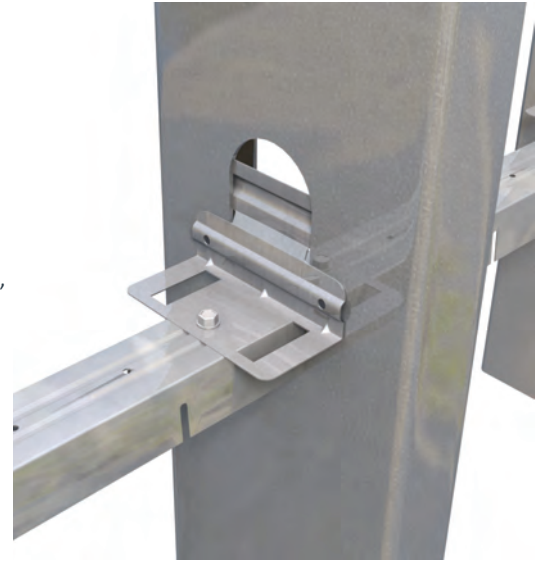
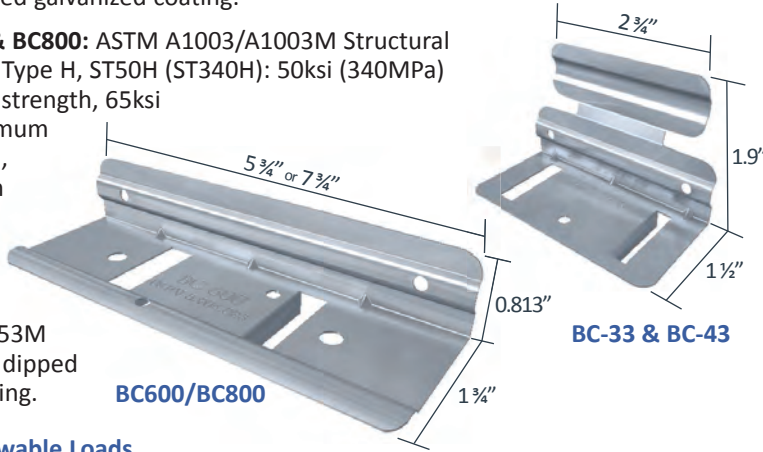

Load Direction US Patent #5,904,023

BridgeClip Allowable Loads

BridgeClip	Stud Depth	Stud Thickness (mils) (ga)	Axially Loaded Stud, Allowable Brace Strength F1 (lbs)	Laterally Loaded Stud, Allowable Torsional Moment M1 (in.lbs)
BC-33, 1	3.625/4	33 (20)	75	132
		43 (18)		143
		54 (16)		156
BC-43, 1	3.625/4	33 (20)	112	168
		43 (18)		179
		54 (16)		192
BC-33, 3	3.625/4	33 (20)	360	192
		43 (18)		221
		54 (16)		252
BC-43, 3	3.625/4	33 (20)	433	240
		43 (18)		297
		54 (16)		360
BC-33, 1	6	33 (20)	75	192
		43 (18)		252
		54 (16)		264
		68 (14)		307
BC-43, 1	6	33 (20)	112	396
		43 (18)		240
		54 (16)		372
		68 (14)		324
BC-33, 3	6	33 (20)	360	371
		43 (18)		468
		54 (16)		228
		68 (14)		254
BC-43, 3	6	33 (20)	433	288
		43 (18)		324
		54 (16)		408
		68 (14)		324
BC600	6	33 (20)	170	480
		43 (18)		684
		54 (16)		792
		68 (14)		864
BC-33, 1	8	33 (20)	75	887
		43 (18)		936
		54 (16)		144
		68 (14)		178
BC-43, 1	8	33 (20)	112	216
		43 (18)		192
		54 (16)		232
		68 (14)		276
BC-33, 3	8	33 (20)	360	240
		43 (18)		280
		54 (16)		324
		68 (14)		288
BC-43, 3	8	33 (20)	433	339
		43 (18)		396
		54 (16)		288
		68 (14)		339
BC800	8	33 (20)	170	756
		43 (18)		790
		54 (16)		828
		68 (14)		851
		97 (12)	360	900

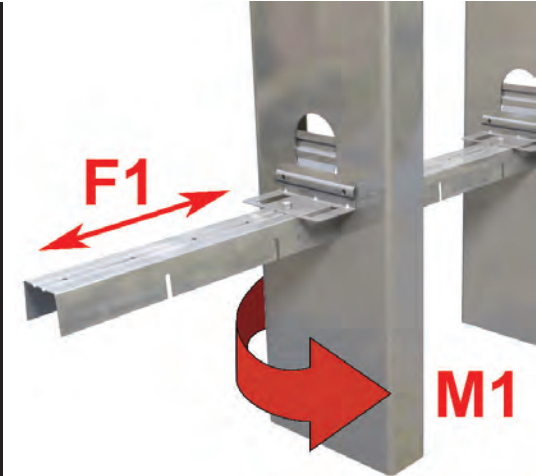

Table Notes:

- Listed ASD allowable loads are based on ultimate test data divided by a factor of safety.
- Listed ASD allowable loads are limited by screw shear or pullout at stud web.

Table Nomenclature	Clip	Qty # 10 Screws into Bridging	Qty # 10 Screws into Stud
BC-33, 1	BC-33	1	0
BC-33, 3	BC-33	1	2
BC-43, 1	BC-43	1	0
BC-43, 3	BC-43	1	2
BC600	BC600	2	2
BC800	BC800	2	2

Nomenclature

BridgeClip is designated by the type BC.

BridgeBar®

Bridging Channel

The Steel Network, Inc. 
 www.steelnetwork.com
 1-888-474-4876

Material Composition

BB75: ASTM A1003/A1003M Structural Grade 33 (230) Type H, ST33H (ST230H): 33ksi (230MPa) minimum yield strength, 45ksi (310MPa) minimum tensile strength, 28mil minimum thickness (22 gauge, 0.0295" design thickness) with ASTM A653/A653M G60 (Z180) hot dipped galvanized coating.

BB150: ASTM A1003/A1003M Structural Grade 50 (340) Type H, ST50H (ST340H): 50ksi (340MPa) minimum yield strength, 65ksi (450MPa) minimum tensile strength, 33mil minimum thickness (20 gauge, 0.0346" design thickness) with ASTM A653/A653M G90 (Z275) hot dipped galvanized coating.

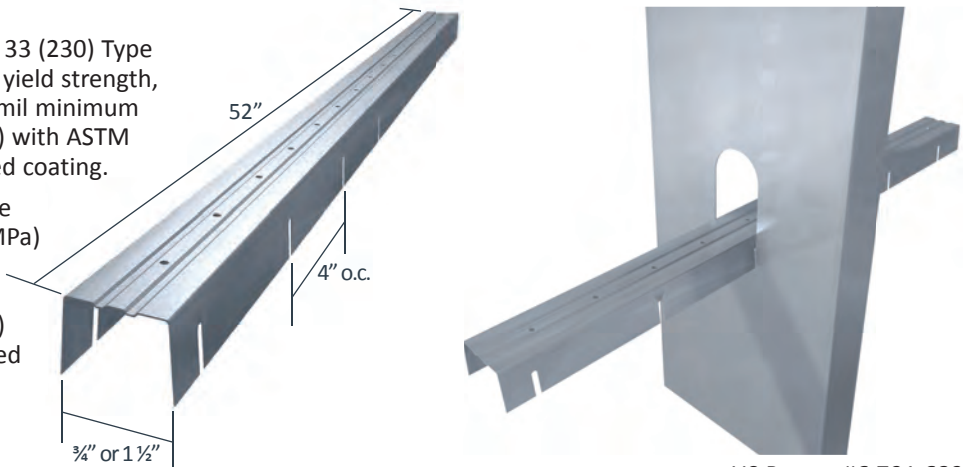

US Patent #6,701,689

Material Analysis

Section	Minimum Thickness (in)	Design Thickness (in)	Yield Strength (ksi)	Effective Section Properties ⁽¹⁾						Effective Section Properties and Allowable Loads ^{(2), (3), (4)}							
				Area		S _x		I _y		S _{xe}	M _a (X-axis)	12" o.c.		16" o.c.		24" o.c.	
				(in ²)	(in ⁴)	(in ³)	(in)	(in ⁴)	(in)			(in ²)	(lbs)	(in ²)	(lbs)	(in ²)	(lbs)
BB75	0.0280	0.0295	33	0.031	0.0021	0.006	0.261	0.0002	0.073	0.006	0.11 (9.3)	N/A	N/A	N/A	N/A	N/A	N/A
BB150	0.0329	0.0346	50	0.068	0.0174	0.023	0.506	0.0007	0.104	0.023	0.69 (57.9)	0.079	1,459	0.081	1,172	0.081	566

Notes:

- Use BridgeClip® for a quick & easy method of securing BridgeBar to stud when required
- Resists compressive loads through the plane of the wall
- Use through 3/4" and 1 1/2" stud punchouts.

¹ Gross section properties are calculated based on the minimum dimensions of the cross section.

² Effective section properties and allowable loads for BridgeBar are calculated based on AISI S100-2007 Specification.

³ Effective section modulus (S_{xe}) is calculated based on the minimum dimensions of the cross section.

⁴ Effective area (A_e) and allowable axial load (P_a) are calculated based on the average dimensions of the cross section.

Securing Bar to Stud

When loads require attachment of BridgeBar to stud, consider the screw shear allowables below for connection of BridgeClip to stud and BridgeBar.

Section	Design Thickness (in)	Yield Strength (ksi)	Allowable Shear/Screw	
			#8 Screw (lbs)	#10 Screw (lbs)
BB150	0.0346	50	237	255

Nomenclature

BridgeBar is available in 3/4" and 1 1/2" widths. Designations are BB75 and BB150.

Example: Stud with 3/4" knockout
Designate: BB75

Cross Sections

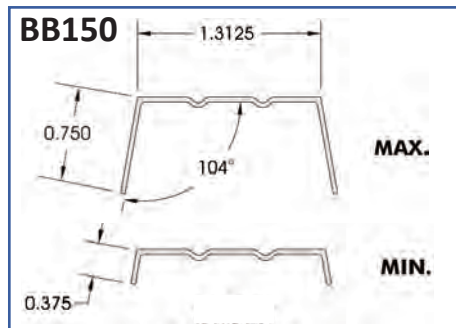
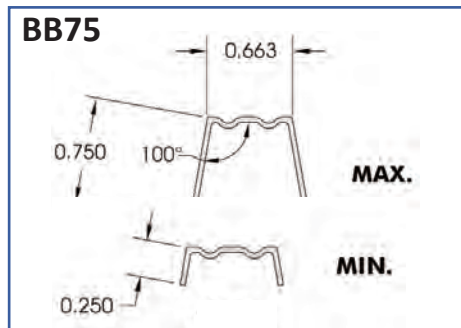

Load Direction

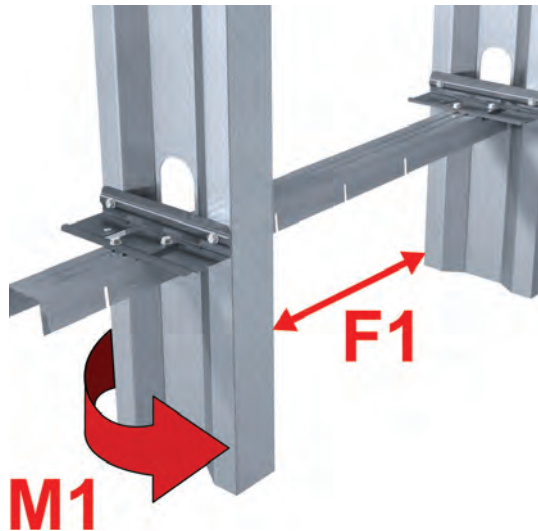

Lap Joint

BridgeBar's 52" length allows for a 4" overlap at joints. Simply fit one end over the other and line up the guide holes for quick & easy placement of screw(s). Joint locations maintain stud spacing as designed through length of the wall system.

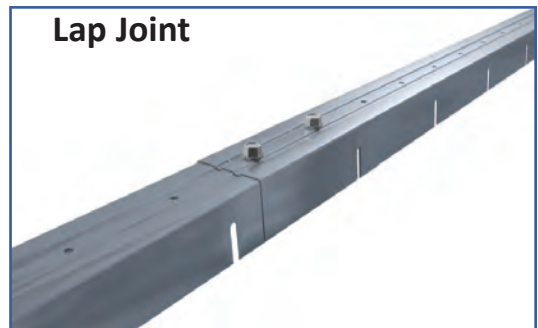

BuckleBridge®

Bridging System

Material Composition

ASTM A1003/A1003M Structural Grade 50 (340) Type H, ST50H (ST340H): 50ksi (340MPa) minimum yield strength, 65ksi (450MPa) minimum tensile strength, 33mil minimum thickness (20 gauge, 0.0346" design thickness) with ASTM A653/A653M G90 (Z275) hot dipped galvanized coating.

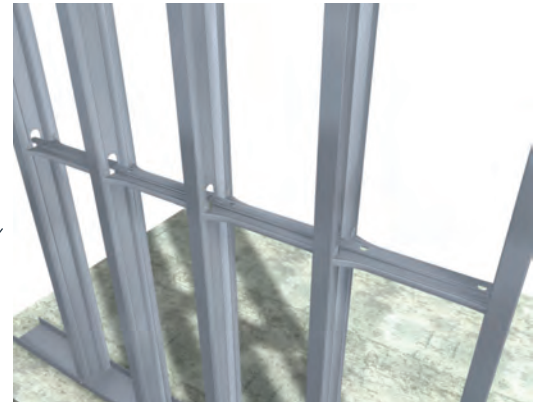
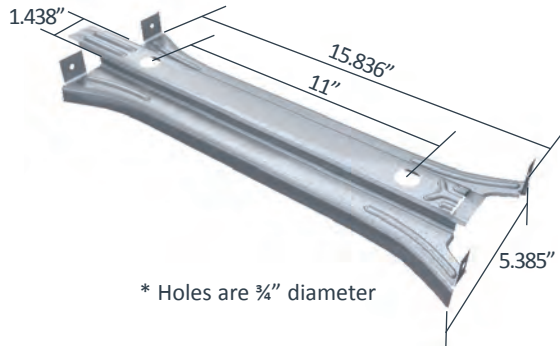

US Patents #7,596,921, #7,836,657 & #8,205,402
 Load Direction

BuckleBridge Allowable Loads

BuckleBridge® Allowable Loads						
Studs 16" o.c.	Axially Loaded Studs				Laterally Loaded Studs	
	Compression Brace		Tension Brace		6" Studs	8" Studs
	F1 (lbs)	Stiffness (lbs/in)	F1 (lbs)	Stiffness (lbs/in)	M1 (in-lb)	M1 (in-lb)
	2,400	31,000	440	2,560	1,290	967

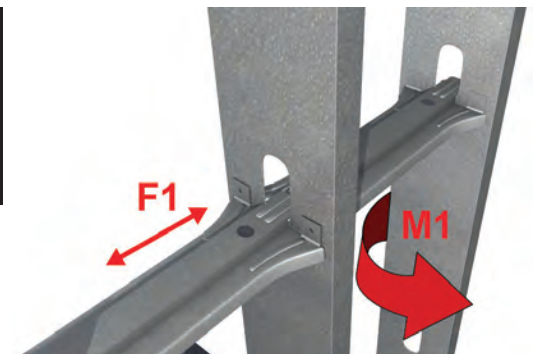

Nomenclature

BuckleBridge comes in one size and is designated *BuckleBridge*®. It is used with 16" o.c. member spacing.

Example Details

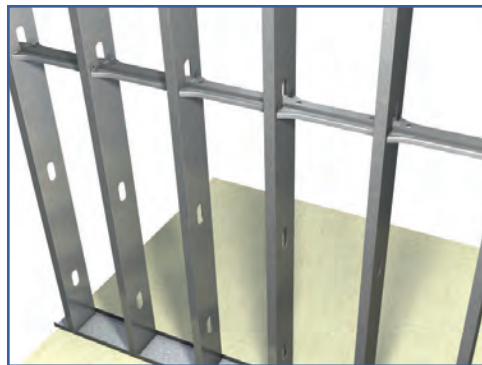

When using BuckleBridge in curtain walls with standard "cee" studs, one screw is only needed every 3rd stud.*

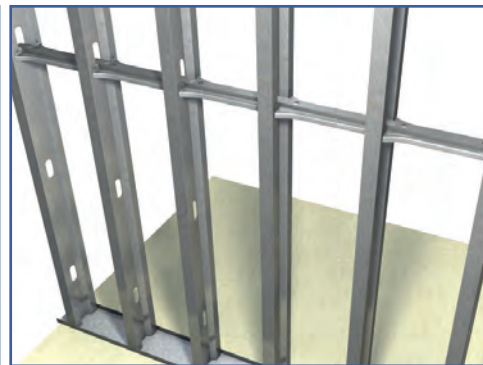

BuckleBridge used in load bearing walls with TSN's SigmaStud



BuckleBridge works just as easily with back-to-back studs.

Notes:

- Resists weak axis buckling and torsional rotation of members.
 - Spaces studs automatically at 16" o.c. Suitable for 6" & 8" walls.
 - Elongated tabs in one end of BuckleBridge lock into a slot at the other end through the stud knockout.
- * Use (1) #10 screw on alternate sides of the BuckleBridge at 3rd stud (48" o.c.) Use (2) #10 screws at end of wall run.

StiffClip® LB

Spandrel Wall Bypass



Material Composition

ASTM A1003/A1003M Structural Grade 50 (340) Type H, ST50H (ST340H): 50ksi (340MPa) minimum yield strength, 65ksi (450MPa) minimum tensile strength, 68mil minimum thickness (14 gauge, 0.0713" design thickness) with ASTM A653/A653M G90 (Z275) hot dipped galvanized coating.

The attachment of StiffClip to the primary structure may be made with PAFs, screw/bolt anchors or weld and is dependent upon the base material (steel or concrete) and the design configuration.

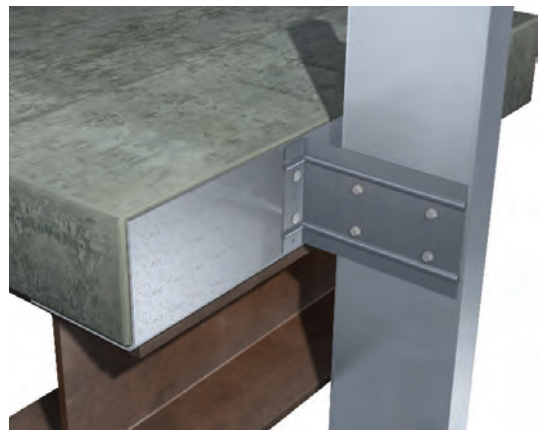
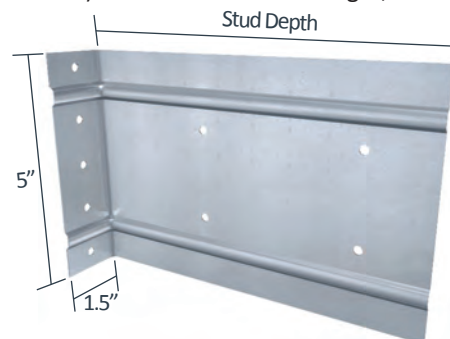

StiffClip LB Allowable Loads

StiffClip® LB, Recommended Allowable Load (lbs): F1 & F2												
Stud		F1 Allowable Loads				F2 Allowable Loads						
		LB362	LB600	LB800 (Standard 2" Offset)	LB1000 & LB1200 (Standard 2" Offset)	LB362 & LB600			LB800 (Standard 2" Offset)		LB1000 (Standard 2" & 4" Offset) & LB1200 (Standard 2" Offset)	
Thickness Mils (ga)	Yield Strength (ksi)	w/3 #12 Screws	w/3-4 #12 Screws	w/3-4 #12 Screws	w/3 #12 Screws	w/2 #12 Screws	w/3 #12 Screws	w/4 #12 Screws	w/3 #12 Screws	w/4 #12 Screws	w/3 #12 Screws	w/4 #12 Screws
		Pattern 2	Patterns 2 & 3	Patterns 4 & 5	Pattern 12	Pattern 1	Pattern 2	Pattern 3	Pattern 4	Pattern 5	Pattern 12	Pattern 13
33 (20)	33	190	191	182	190	377	565	754	565	754	565	752
33 (20)	50	275	275	182	275	544	817	1,089	817	1,089	816	1,062
43 (18)	33	248	248	182	248	561	841	1,122	841	1,122	840	1,062
43 (18)	50	359	359	182	359	810	1,215	1,620	1,215	1,620	1,062	1,062
54 (16)	33	312	312	182	312	789	1,183	1,577	1,183	1,577	1,062	1,062
54 (16)	50	450	450	182	450	1,139	1,709	1,811	1,709	1,811	1,062	1,062
68 (14)	50	568	536	182	532	1,610	1,811	1,811	1,811	1,811	1,062	1,062
97 (12)	50	768	536	182	532	1,698	1,811	1,811	1,811	1,811	1,062	1,062
Max Allowable Clip Load		768	536	182	532	1,811			1,811		1,062	

StiffClip® LB, Recommended Allowable Load (lbs): F3															
Stud		LB362			LB600 (Standard 1" Offset)			LB800 (Standard 2" Offset)				LB800 (4" Offset)			
Thickness Mils (ga)	Yield Strength (ksi)	w/2 #12 Screws	w/3 #12 Screws	w/4 #12 Screws	w/2 #12 Screws	w/3 #12 Screws	w/4 #12 Screws	w/3 #12 Screws	w/4 #12 Screws	w/6 #12 Screws	w/10 #12 Screws	w/4 #12 Screws	w/6 #12 Screws	w/8 #12 Screws	
		Pattern 1	Pattern 2	Pattern 3	Pattern 1	Pattern 2	Pattern 3	Pattern 4	Pattern 5	Pattern 6	Pattern 7	Pattern 8	Pattern 9	Pattern 10	
33 (20)	33	235	350	468	251	377	503	332	441	534	793	259	331	417	
33 (20)	50	340	506	678	362	544	727	479	637	773	1,149	376	479	604	
43 (18)	33	350	522	697	373	561	749	494	656	795	1,182	386	493	622	
43 (18)	50	506	753	1,009	539	810	1,082	713	948	1,150	1,710	559	713	899	
54 (16)	33	493	733	981	524	789	1,053	694	923	1,119	1,663	544	693	875	
54 (16)	50	711	1,059	1,417	757	1,139	1,521	1,002	1,269	1,616	2,401	785	1,001	1,263	
68 (14)	50	1,006	1,498	2,004	1,071	1,610	1,792	1,269	1,269	2,286	3,397	1,111	1,417	1,561	
97 (12)	50	1,061	1,579	2,114	1,129	1,698	1,792	1,269	1,269	2,411	3,583	1,172	1,494	1,561	
Max Allowable Clip Load		2,658			1,792			1,269		3,863			1,561		

****StiffClip LB Allowable Load tables and important notes continued on next page.**

Nomenclature

StiffClip LB is available for various stud depths. To specify, multiply stud depth by 100.

Example: 6" stud depth
Designate: StiffClip® LB600

StiffClip® LB, Recommended Allowable Load (lbs): F3										
Stud		LB1000 (Standard 2" Offset)			LB1200 (Standard 2" Offset)			LB1000 (4" Offset)		
Thickness Mils (ga)	Yield Strength (ksi)	w/2 #12 Screws	w/3 #12 Screws	w/4 #12 Screws	w/2 #12 Screws	w/3 #12 Screws	w/4 #12 Screws	w/4 #12 Screws	w/6 #12 Screws	w/10 #12 Screws
		Pattern 11	Pattern 12	Pattern 13	Pattern 11	Pattern 12	Pattern 13	Pattern 14	Pattern 15	Pattern 16
33 (20)	33	203	364	406	211	381	421	290	410	602
33 (20)	50	294	525	588	305	550	610	419	593	871
43 (18)	33	302	541	605	314	566	627	431	610	896
43 (18)	50	438	782	875	454	818	907	624	883	1,192
54 (16)	33	426	761	851	441	796	883	607	859	1,192
54 (16)	50	615	1,099	1,229	637	1,150	1,275	876	1,192	1,192
68 (14)	50	869	1,554	1,739	902	1,627	1,803	1,192	1,192	1,192
97 (12)	50	917	1,639	1,793	951	1,715	1,899	1,192	1,192	1,192
Max Allowable Clip Load		1,793			1,899			1,192		

Notes:

- Allowable load tables incorporate eccentric loading of fasteners. Values with a welded connection may increase.
- Fasten within 3/4" from the angle heel (centerline of the 1 1/2" leg) to minimize eccentric load transfer.
- StiffClip LB resists horizontal and vertical loads.
- Allowable loads have not been increased for wind, seismic, or other factors.
- Loads listed reflect force in a single direction. When multiple loads react on the connection, it is the responsibility of the designer to check the interaction of forces.
- Torsional effects are considered on screw group for F3 allowable loads. It is assumed that half of the torsional moment is taken by the connection to the structure and half is taken by the connection to the stud.
- Design loads consider loads on the clip and #12 screw fasteners to the stud web.
- Strengthening ribs are present in 3 5/8", 6", and 8" sizes. StiffClip LB's 10" and 12" sizes contain 1/2" return lips on the top and bottom of the leg attaching to the stud for increased stiffness.

Load Direction

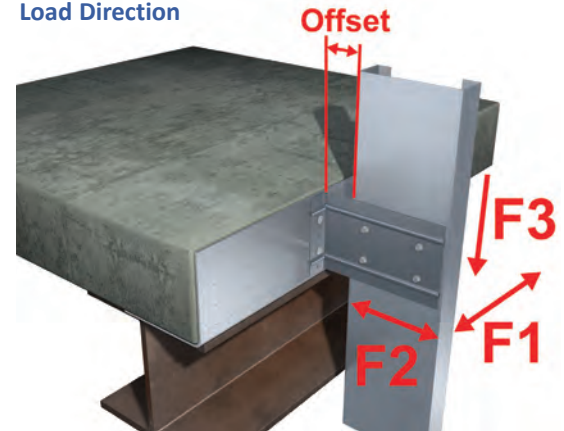

Screw Patterns

****Important Consideration:** Pattern diagrams indicate fastener placement only. Standard StiffClip LB products come with 4 predrilled guide holes as depicted in Patterns 3, 5, & 13 (LB362/LB600, LB800, & LB1000/1200). Alternate patterns can be utilized in the field or be accommodated as a TSN special part request. Contact TSN Sales for information regarding special part requests.

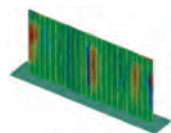
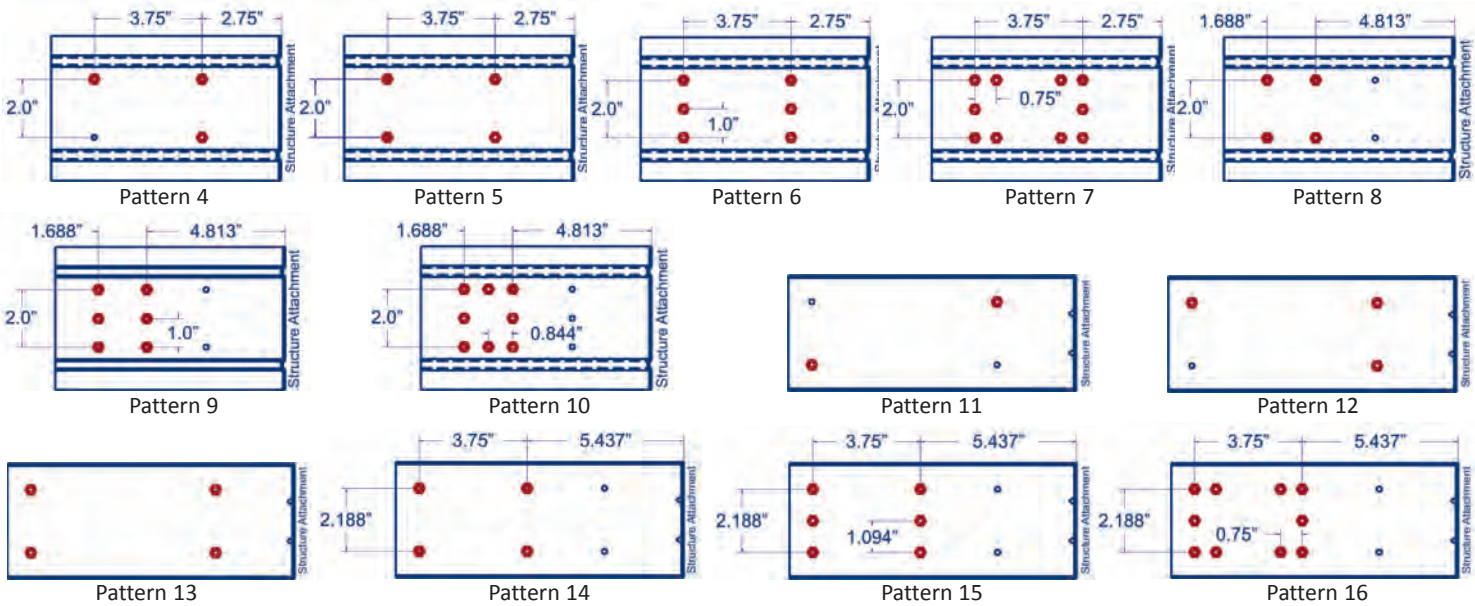
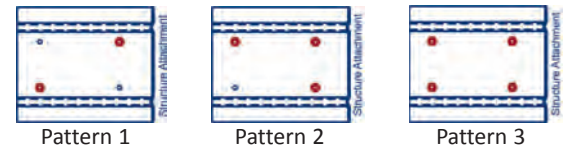

StiffClip LB Series
Blast and Seismic Design Data
www.steelnetwork.com

** For more information or to review a copy of this report, please visit our website at <http://www.steelnetwork.com/Site/TechnicalData>

StiffClip® LB-HD

Spandrel Wall Bypass for Seismic Conditions

The Steel Network, Inc. 
 www.steelnetwork.com
 1-888-474-4876

Material Composition

ASTM A1003/A1003M Structural Grade 50 (340) Type H, ST50H (ST340H): 50ksi (340 MPa) minimum yield strength, 65ksi minimum tensile strength, 68mil minimum thickness (14 gauge, 0.0713" design thickness) with ASTM A653/653M G90 (Z275) hot dipped galvanized coating.

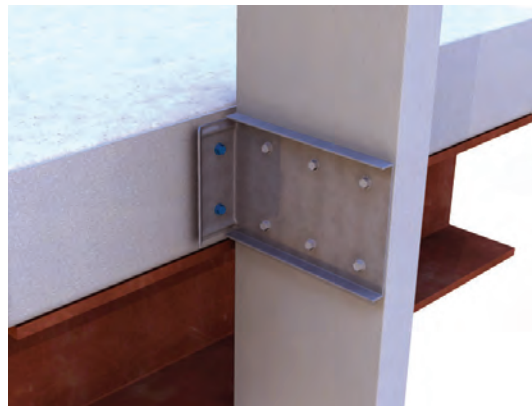
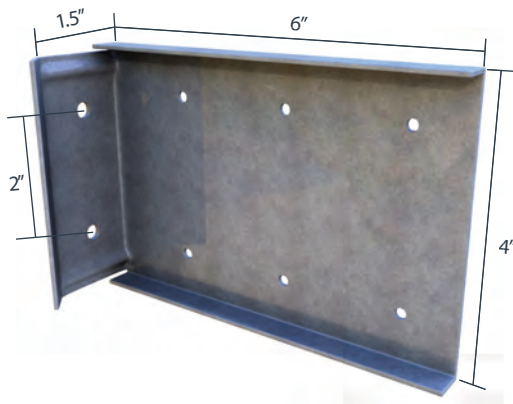

StiffClip LB-HD Allowable Loads

StiffClip® LB-HD, Recommended Allowable Load (lbs): F1, F2 & F3								
Stud		F1 Allowable (ASD) Loads	F2 Allowable (ASD) Loads			F3 Allowable (ASD) Loads		
Thickness Mils (ga)	Yield Strength (ksi)	w/3-6' #12 Screws	w/3 #12 Screws	w/4 #12 Screws	w/6 #12 Screws	w/3 #12 Screws	w/4 #12 Screws	w/6 #12 Screws
33 (20)	33	191	524	754	1,130	318	450	599
43 (18)	33	248	780	1,122	1,130	474	670	892
54 (16)	33	312	1,096	1,130	1,130	666	942	1,254
54 (16)	50	450	1,130	1,130	1,130	962	1,361	1,811
68 (14)	50	567	1,130	1,130	1,130	1,361	1,924	1,966
97 (12)	50	809	1,130	1,130	1,130	1,435	1,966	1,966
Maximum Allowable Clip Load		857	1,130			1,966		

Note:

- Fasten within 3/4" from the angle heel (centerline of the 1 1/2" leg) to minimize eccentric load transfer.
 - Guide holes for stud connection are 0.172" diameter for #12 screws. Guide holes for structure connection are 0.375" diameter for (2) 1/4" concrete screws.
 - StiffClip LB-HD resists both horizontal and vertical loads.
 - Allowable loads have not been increased for wind, seismic, or other factors.
 - Loads listed reflect force in a single direction. When multiple loads act on the connection, it is the responsibility of the designer to check the interaction of forces.
 - The recommended allowable load is for the clip and attachment to the stud only. The design professional must design attachment to the primary structure.
 - Torsional effects are considered on screw group for F2 & F3 allowable loads. It is assumed that half of the torsional moment is taken by the connection to the structure and half is taken by the connection to the stud.
- ¹ Only two screws near clip support are considered effective.

Load Direction

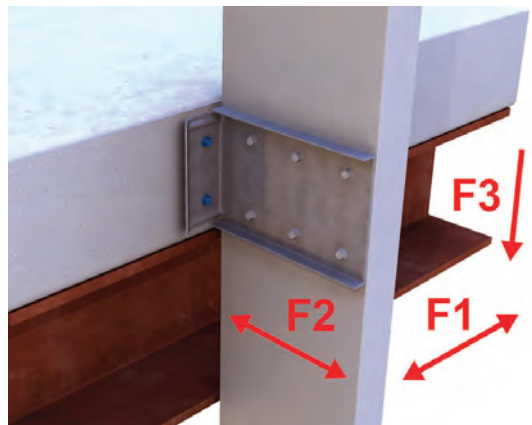

Nomenclature

StiffClip LB-HD is designed to be used with 6" studs and is designated *StiffClip® LB600-HD*

Screw Patterns

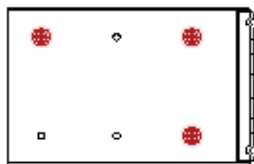

3 Screw Pattern

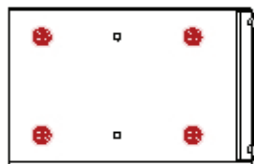

4 Screw Pattern

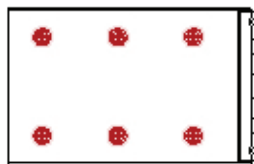

6 Screw Pattern

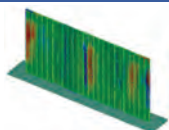

StiffClip LB-HD Series
 Blast and Seismic Design Data
 www.steelnetwork.com

** For more information or to review a copy of this report, please visit our website at <http://www.steelnetwork.com/Site/TechnicalData>

VertiClip® Splice

Multi-Stud Bypass

Material Composition

ASTM A1003/A1003M Structural Grade 50 (340) Type H, ST50H (ST340H): 50ksi (340MPa) minimum yield strength, 65ksi (450MPa) minimum tensile strength, 68mil minimum thickness (14 gauge, 0.0713" design thickness) with ASTM A653/A653M G90 (Z275) hot dipped galvanized coating.

The attachment of VertiClip to the primary structure may be made with PAFs, screw/bolt anchors or weld and is dependent upon the base material (steel or concrete) and the design configuration.

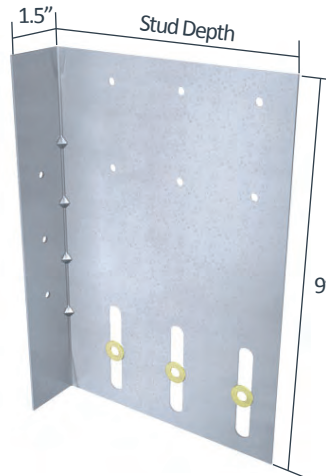

US Patent # 5,906,080

VertiClip Splice Allowable Loads

VertiClip® Splice, Recommended Allowable Load (lbs): F2 & F3												
Stud		F2 Load Direction					F3 Load Direction					
		Splice600 & Splice800					Splice600			Splice800 (up to 2" offset for 6" Studs)		
Thickness Mills (ga)	Yield Strength (ksi)	Qty #12 screws Upper Half (Listed 1st) / Qty #12 screws Lower Half (Listed 2nd)					#12 Screws in Upper Half			#12 Screws in Upper Half		
		2 screws / 2 screws	4 screws / 2 screws	4 screws / 3 screws	6 screws / 2 screws	6 screws / 3 screws	2 screws	4 screws	6 screws	2 screws	4 screws	6 screws
33 (20)	33	754	1,041	1,229	1,041	1,229	216	431	562	171	341	428
33 (20)	50	1,089	1,208	1,328	1,208	1,328	313	623	813	248	493	618
43 (18)	33	1,122	1,225	1,328	1,225	1,328	322	642	837	255	508	637
43 (18)	50	1,328	1,328	1,328	1,328	1,328	465	928	1,209	369	733	920
54 (16)	33	1,328	1,328	1,328	1,328	1,328	453	903	1,177	259	714	895
54 (16)	50	1,328	1,328	1,328	1,328	1,328	654	1,304	1,700	518	1,031	1,293
68 (14)	50	1,328	1,328	1,328	1,328	1,328	925	1,844	2,404	733	1,457	1,828
97 (12)	50	1,328	1,328	1,328	1,328	1,328	976	1,944	2,432	773	1,537	1,927
Maximum Allowable Clip Load		1,328					2,432			2,272		

Notes:

- Fasten within 3/4" from the angle heel centerline of the 1 1/2" leg.
- Total vertical deflection of up to 2" (1" up and 1" down). Deflection requirements greater than 1" up and down are available.
- Allowable loads have not been increased for wind, seismic, or other factors.
- Torsional effects are considered on screw group for F2 & F3 allowable loads. It is assumed that half of the torsional moment is taken by the connection to the structure and half is taken by the connection to the stud.
- Loads listed reflect force in a single direction. When multiple loads react on the connection, it is the responsibility of the designer to check the interaction of forces.

Screw Patterns



2 Screw Pattern



4 Screw Pattern



6 Screw Pattern

Nomenclature

VertiClip Splice is designated by multiplying stud depth by 100.

Example: 6" stud.

Designate: VertiClip® Splice600

Load Direction

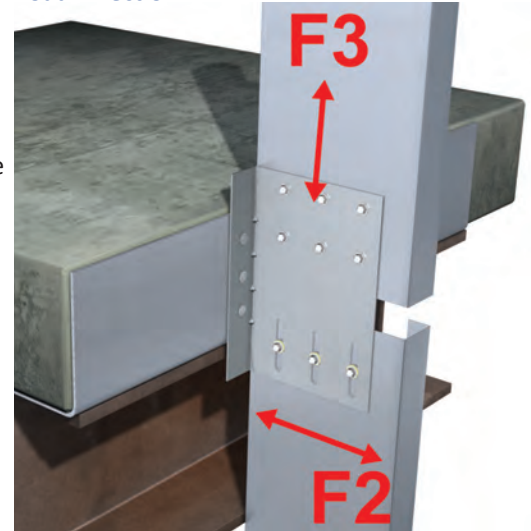

* Clip shown is a left version of VertiClip Splice. Right side versions can be made as a custom part.

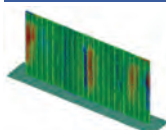

VertiClip Splice Series
 Blast and Seismic Design Data
 www.steelnetwork.com**

** For more information or to review a copy of this report, please visit our website at <http://www.steelnetwork.com/Site/TechnicalData>

StiffClip® CL

Floor Tie

The Steel Network, Inc. 
 www.steelnetwork.com
 1-888-474-4876

Material Composition

68mil Clip: ASTM A1003/A1003M Structural Grade 50 (340) Type H, ST50H (ST340H): 50ksi (340MPa) minimum yield strength, 65ksi (450MPa) minimum tensile strength, 68mil minimum thickness (14 gauge, 0.0713" design thickness) with ASTM A653/A653M G90 (Z275) hot dipped galvanized coating.

118mil Clip: ASTM A1003/A1003M Structural Grade 50 (340) Type H, ST50H (ST340H): 50ksi (340MPa) minimum yield strength, 65ksi (450MPa) minimum tensile strength, 118mil minimum thickness (10 gauge, 0.1242" design thickness) with ASTM A653/A653M G90 (Z275) hot dipped galvanized coating.

"H" Plate: ½" steel, ASTM A36, 36ksi min yield, 58-80ksi min tensile, with ASTM B633 Type II Yellow Zinc Coating, or Paint, or Equivalent.

The attachment of StiffClip to the primary structure may be made with PAFs, screw/bolt anchors or weld and is dependent upon the base material (steel or concrete) and the design configuration.

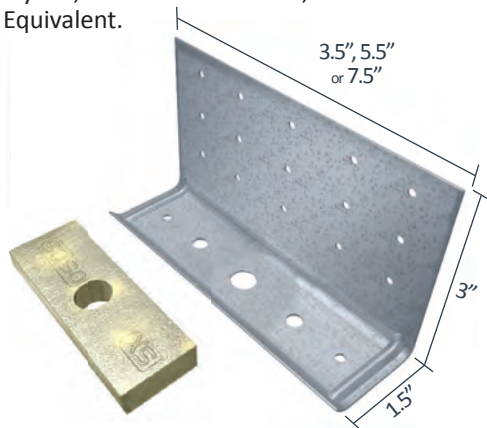
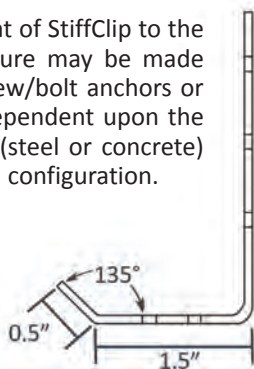

CL (H) Plate

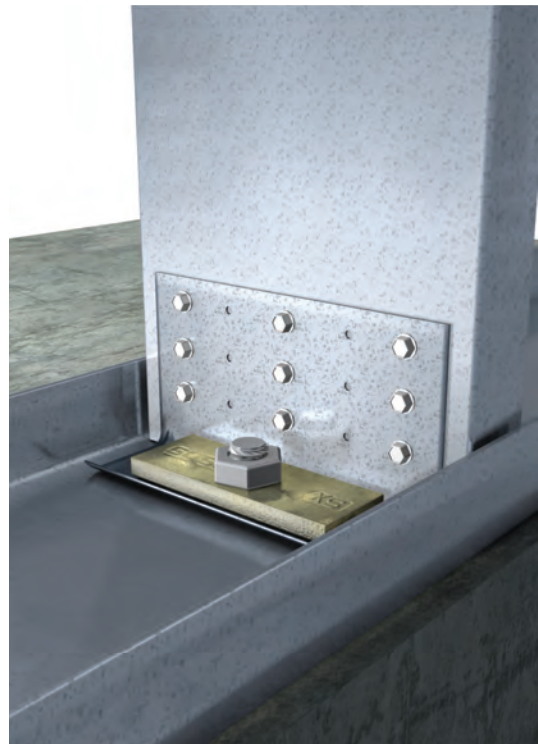

US Patent #7,533,508

StiffClip CL Allowable Loads

StiffClip® CL362/400, Recommended Allowable Load (lbs and inches): F1, F2, F3, M1 & Stiffness																
Stud		CL362/400-68					CL362/400-118					CL362/400-118 (H)				
Thickness Mils (ga)	Yield Strength (ksi)	4 #12 Screws, Pattern 1					4 #12 Screws, Pattern 1					9 #12 Screws, Pattern 2				
		F1 (lbs)	F2 (lbs)	F3 (lbs)	M1 (in-lbs)	Stiffness (in-lbs/rad)	F1 (lbs)	F2 (lbs)	F3 (lbs)	M1 (in-lbs)	Stiffness (in-lbs/rad)	F1 (lbs)	F2 (lbs)	F3 (lbs)	M1 (in-lbs)	Stiffness (in-lbs/rad)
33 (20)	33	191	535	754	1,108	108,054	191	535	754	1,108	297,793	286	980	1,696	1,653	457,277
33 (20)	50	275	773	1,089	1,601		275	773	1,089	1,601		413	1,415	2,450	2,388	
43 (18)	33	248	796	1,122	1,649		248	796	1,122	1,649		373	1,458	2,524	2,460	
43 (18)	50	359	1,150	1,151	1,804		359	1,150	1,620	2,383		538	2,107	3,646	3,554	
54 (16)	33	312	1,120	1,151	1,804		312	1,120	1,577	2,319		468	2,050	3,549	3,459	
54 (16)	50	450	1,617	1,151	1,804		450	1,617	2,225	3,350		676	2,961	5,126	4,996	
68 (14)	50	567	1,917	1,151	1,804		567	2,287	2,225	3,936		851	4,187	5,713	6,716	
97 (12)	50	809	1,917	1,151	1,804		809	2,411	2,225	3,936		1,214	4,415	5,713	6,716	
118 (10)	50	856	1,917	1,151	1,804	856	2,411	2,225	3,936	1,284	4,415	5,713	6,716			
Max Allowable Clip Load		1,416	1,917	1,151	1,804		2,423	4,107	2,225	3,936		2,598	4,978	5,713	6,716	

StiffClip® CL600, Recommended Allowable Load (lbs and inches): F1, F2, F3, M1 & Stiffness																
Stud		CL600-68					CL600-118					CL600-118 (H)				
Thickness Mils (ga)	Yield Strength (ksi)	6 #12 Screws, Pattern 3					6 #12 Screws, Pattern 3					10 #12 Screws, Pattern 4				
		F1 (lbs)	F2 (lbs)	F3 (lbs)	M1 (in-lbs)	Stiffness (in-lbs/rad)	F1 (lbs)	F2 (lbs)	F3 (lbs)	M1 (in-lbs)	Stiffness (in-lbs/rad)	F1 (lbs)	F2 (lbs)	F3 (lbs)	M1 (in-lbs)	Stiffness (in-lbs/rad)
33 (20)	33	286	874	1,067	1,713	160,215	286	874	1,130	1,713	354,427	381	1,481	1,884	3,140	525,127
33 (20)	50	413	1,263	1,067	2,435		413	1,263	1,633	2,475		550	2,139	2,722	4,537	
43 (18)	33	373	1,301	1,067	2,435		373	1,301	1,682	2,549		497	2,204	2,804	4,673	
43 (18)	50	538	1,880	1,067	2,435		538	1,880	2,225	3,683		718	3,184	4,051	6,755	
54 (16)	33	468	1,830	1,067	2,435		468	1,830	2,225	3,585		624	3,099	3,943	6,571	
54 (16)	50	676	2,510	1,067	2,435		676	2,642	2,225	5,177		901	4,476	5,695	7,306	
68 (14)	50	851	2,510	1,067	2,435		851	3,736	2,225	5,702		1,134	6,329	6,007	7,306	
97 (12)	50	1,214	2,510	1,067	2,435		1,214	3,939	2,225	5,702		1,618	6,455	6,007	7,306	
118 (10)	50	1,284	2,510	1,067	2,435	1,284	3,939	2,225	5,702	1,712	6,455	6,007	7,306			
Max Allowable Clip Load		1,421	2,510	1,067	2,435		2,580	4,107	2,225	5,702		4,158	6,455	6,007	7,306	

****StiffClip CL Allowable Load tables and important notes continued on next page.**

StiffClip® CL800, Recommended Allowable Load (lbs and inches): F1, F2, F3, M1 & Stiffness																
Stud		CL800-68					CL800-118					CL800-118 (H)				
Thickness Mils (ga)	Yield Strength (ksi)	6 #12 Screws, Pattern 5					6 #12 Screws, Pattern 5					10 #12 Screws, Pattern 6				
		F1 (lbs)	F2 (lbs)	F3 (lbs)	M1 (in-lbs)	Stiffness (in-lbs/rad)	F1 (lbs)	F2 (lbs)	F3 (lbs)	M1 (in-lbs)	Stiffness (in-lbs/rad)	F1 (lbs)	F2 (lbs)	F3 (lbs)	M1 (in-lbs)	Stiffness (in-lbs/rad)
33 (20)	33	286	976	1,077	2,479	190,670	286	976	1,130	2,479	548,677	381	1,664	1,884	4,710	696,515
33 (20)	50	413	1,410	1,077	2,860		413	1,410	1,633	3,582		550	2,404	2,722	6,805	
43 (18)	33	373	1,452	1,077	2,860		373	1,452	1,682	3,689		497	2,476	2,804	7,010	
43 (18)	50	538	2,098	1,077	2,860		538	2,098	2,431	5,330		718	3,577	4,051	10,128	
54 (16)	33	468	2,042	1,077	2,860		468	2,042	2,366	5,188		624	3,482	3,943	9,858	
54 (16)	50	676	2,662	1,077	2,860		676	2,950	2,666	7,493		901	5,029	5,695	11,143	
68 (14)	50	851	2,662	1,077	2,860		851	4,171	2,666	8,229		1,134	7,110	7,446	11,143	
97 (12)	50	1,214	2,662	1,077	2,860		1,214	4,398	2,666	8,229		1,618	7,497	7,446	11,143	
118 (10)	50	1,284	2,662	1,077	2,860		1,284	4,398	2,666	8,229		1,712	7,497	7,446	11,143	
Max Allowable Clip Load		1,435	2,662	1,077	2,860		3,356	6,410	2,666	8,229		4,816	8,274	7,446	11,143	

Notes:

- StiffClip CL resists vertical, horizontal, and torsional loads.
- Allowable load tables incorporate eccentric loading of fasteners. Values with welded connection may increase.
- Fasten within 3/4" from the angle heel (centerline of the 1 1/2" leg), using pre-drilled holes.
- Center hole is 0.563" in diameter for 1/2" anchor. Middle guide holes are 0.313" in diameter. Outer guide holes and guide holes in 3" leg are 0.141" in diameter.
- Guide holes are in place for fastener installation efficiency. All guide holes may not require fasteners. Fastener amount determined by the designer. Screw fasteners should be symmetrically placed in guide holes. Refer to screw pattern diagrams below for placement.
- Loads listed reflect force in a single direction. When multiple loads react on the connection, it is the responsibility of the designer to check the interaction of forces.
- Allowable loads have not been increased for wind, seismic, or other factors.
- Torsional effects are considered on screw group for F2 & F3 allowable loads. It is assumed that half of the torsional moment is taken by the connection to the structure and half is taken by the connection to the stud.
- M1 loads are reported as Max. Load divided by a Factor of Safety. M1 loads maybe limited by the Serviceability Load calculated as Clip Stiffness times the Serviceability Limit in radians.
- Stiffness is the Allowable Clip Moment divided by the clip rotation measured at Half the Max Allowable Clip Moment.

Load Direction

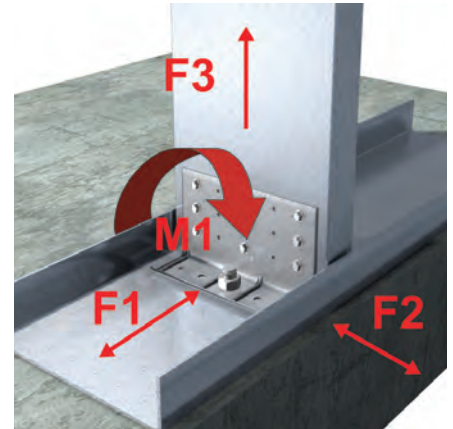

Screw Patterns

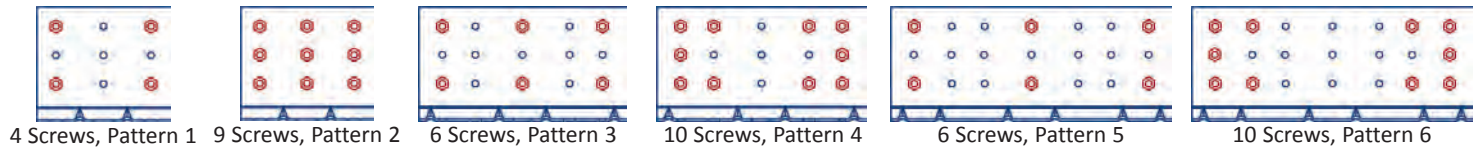

Nomenclature

To specify StiffClip CL on drawings, multiply stud depth by 100, followed by the appropriate material thickness, based on strength required (see load tables). The StiffClip CL118(H) utilizes a plate in the 1 1/2" leg (shown on page 1).

Example: 6" stud, uplift load of 650lbs

Designate: StiffClip® CL600-68

Anchor Bolt Design

The following equation for tension force in the anchor is derived using the assumed bearing stress distribution shown in the figure to the right. This assumed stress distribution provides a conservative anchor force approximation.

$$T = \frac{M}{(2/3)(d_{clip}/2)} = \frac{3M}{d_{clip}}$$

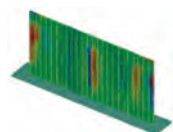
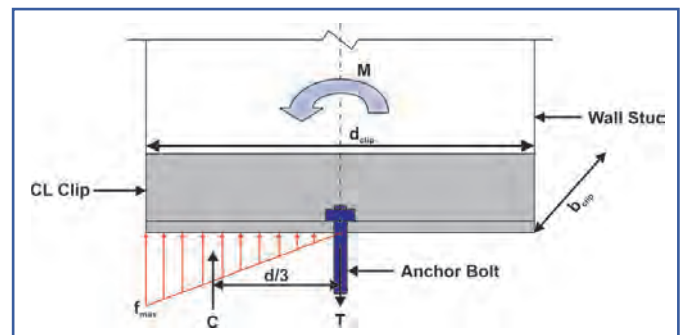

StiffClip CL Series
Blast and Seismic Design Data
www.steelnetwork.com

** For more information or to review a copy of this report, please visit our website at <http://www.steelnetwork.com/Site/TechnicalData>

MidWall™

Partial Wall Framing

The Steel Network, Inc. 
 www.steelnetwork.com
 1-888-474-4876

Material Composition

MidWall: ASTM A1003/A1003M Structural Grade 50 (340) Type H, ST50H (ST340H), 50ksi (340MPa) minimum yield strength, 65ksi (450MPa) minimum tensile strength, G90 (Z275) hot-dipped galvanized coating. Material Thickness = 118mil (10 gauge, 0.1242" design thickness) for 250MW and 362MW. Material Thickness = 97mil (12 gauge, 0.1017" design thickness) for 600 MW.

MidWall Plate: ASTM A36/A36M: 36ksi (250MPa) minimum yield strength, 58-80ksi (400-550MPa) tensile strength, ½" minimum thickness.

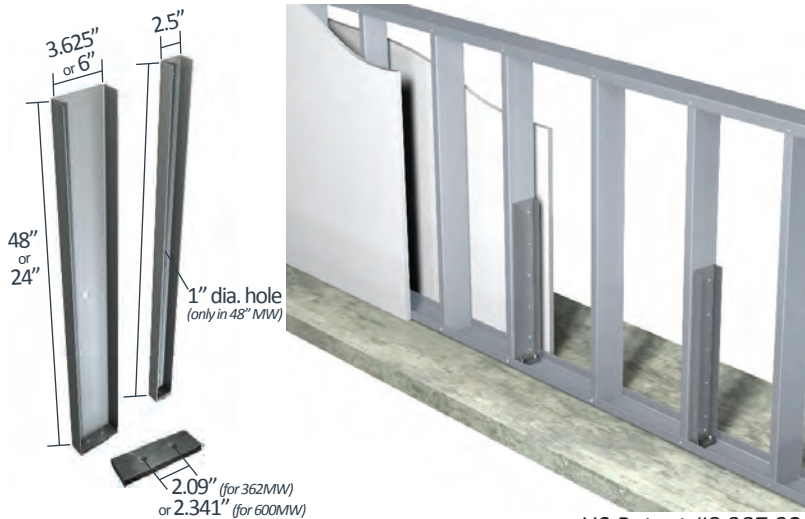

MidWall Allowable Loads

Wall Width (in)	MidWall™ Member	Maximum Point Load @ 48" (ASD), lbs	Maximum Base Moment, lbs-in
2 ½	250MW	128	6,150
3 5/8"	362MW	332	15,940
6	600MW	407	19,540

Notes

- MidWall is designed to support out-of-plane loading in cantilevered partial wall systems that are unsupported at the top track.
- Out-of-plane loads are transferred to the floor system through plate nested in the flanges of the member with two 3/8" diameter fasteners (or one ½" diameter fastener for 250MW) used for the connection.
- MidWall may be used in place of standard framing members, or in conjunction with them to frame the wall.

Nomenclature

MidWall is currently available in two heights and three depths. Product nomenclature lists the member depth first followed by the height in inches

Example: 6" web depth, 24" tall MidWall

Designate: 600MW-24

Example Details

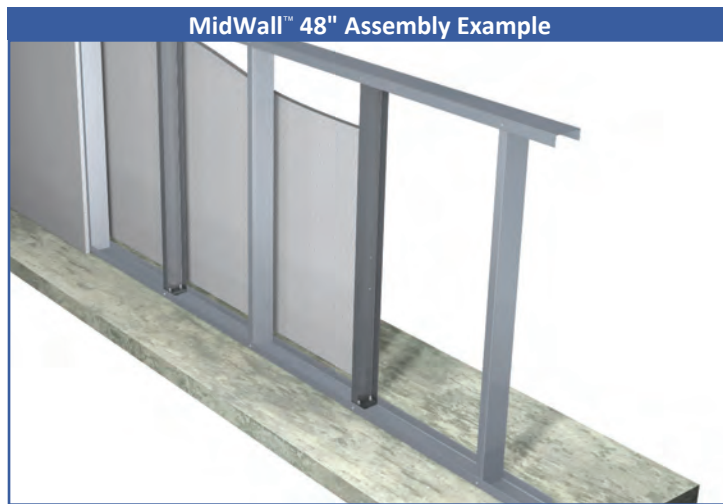
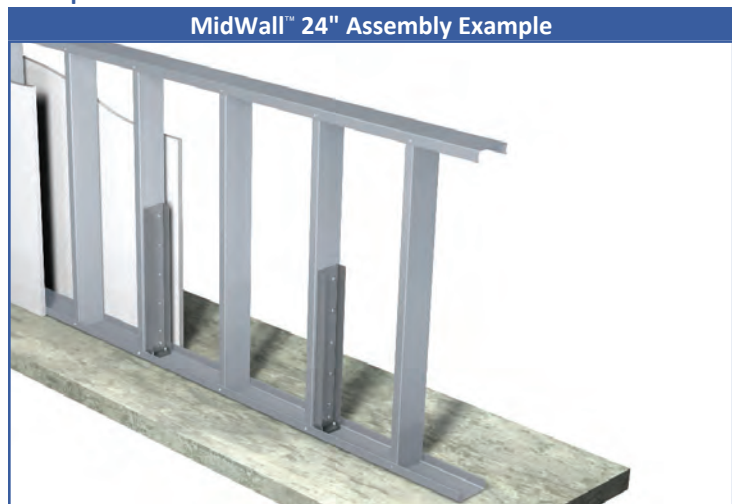

MidWall 24" is generally used in interior half walls of less than 48" in height. Attach MidWall 24" to a 54mil stud with #12 screws through all pre-drilled guide holes. Other studs in the walls are typical infill studs. Maximum spacing between MidWall connectors is 36" o.c. (see table on following page). Contact TSN Technical Services at (888) 474-4876 for design recommendations.

MidWall 48" is used in interior half walls equal to or more than 48" in height. Use one MidWall 48" as a substitute for a stud at the specified spacing, or attach to a 54mil stud with #12 screws through all pre-drilled guide holes. Maximum spacing between MidWall connectors is 36" o.c.

Design Information

Criteria:

IBC 2018

Refer to Section 1607.8.1

Applications:

- Handrails and Guards
- Interior Half Walls
- Parapets
- Ribbon Windows

Handrails and Guards:

- 50 lb/ft applied in any direction at the top of wall
- 200 lbs applied in any direction at any point at the top of the wall

Parapets & Ribbon Windows:

- Design Wind Pressure

Interior Half Walls:

- Design internal pressure

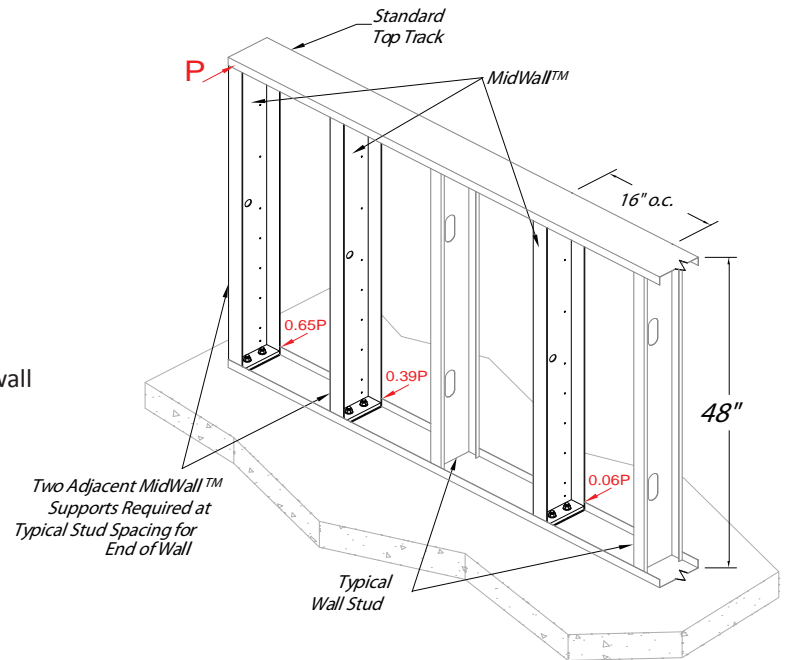

Design Procedure

The top track spanning between MidWall members acts as a load distribution member capable of distributing localized loads to multiple MidWall members. It is recommended to design the track in these applications. Refer to the diagram above for an example of the distribution of the point load, P, to adjacent MidWall supports. At the end of the wall, MidWall is required at adjacent stud spacings. Designed spacing begins after two adjacent end supports.

Max Applied Tension (T _u) on One Anchor (lbs)	250 MidWall™ ½" Anchorage Options (4,000 psi minimum concrete strength)
900	½" Screw-Bolt+, 2 ½" Nominal Embed. (Dewalt)
	½" Kwik HUS-EZ, 2 ¼" Nominal Embed. (Hilti)
1,200	½" Screw-Bolt+, 2 ½" Nominal Embed. (Dewalt)
	½" Kwik HUS-EZ, 2 ¼" Nominal Embed. (Hilti)
1,600	½" Screw-Bolt+, 3" Nominal Embed. (Dewalt)
	½" Kwik HUS-EZ, 3" Nominal Embed. (Hilti)

Max Applied Tension (T _u) on One Anchor (lbs)	362/600 MidWall™ ¾" Anchorage Options (4,000 psi minimum cracked concrete strength)
1,800	¾" Screw-Bolt+, 3 ¼" Nominal Embed. (Dewalt)
	¾" Kwik Bolt TZ2 - CS, 3" Nominal Embed. (Hilti)
2,200	¾" Screw-Bolt+, 3 ¼" Nominal Embed. (Dewalt)
	¾" Kwik Bolt TZ2 - CS, 3" Nominal Embed. (Hilti)
2,400	¾" HAS-E Threaded Rod w/ HIT-HY 200 Epoxy, 3" Eff. Embed (Hilti)
3,200	¾" HAS-E Threaded Rod w/ HIT-HY 200 Epoxy, 4" Eff. Embed (Hilti)

StiffClip® TD

Uplift Connector

The Steel Network, Inc. 
 www.steelnetwork.com
 1-888-474-4876

Material Composition

Clip: ASTM A1003/A1003M Structural Grade 55 (380) Type H, ST55H (ST380H): 55ksi (380MPa) minimum yield strength, 70ksi (480MPa) minimum tensile strength, 118mil minimum thickness (10 gauge, 0.1242" design thickness) with ASTM A653/A653M G90 (Z275) hot dipped galvanized coating.

TD Plate: ASTM A36/A36M: 36ksi (250MPa) minimum yield strength, 58-80ksi (400-550MPa) minimum tensile strength, with ASTM B633 Type II Yellow Zinc Coating, Paint, Powder Coating, or E-Coating, or approved equivalent.

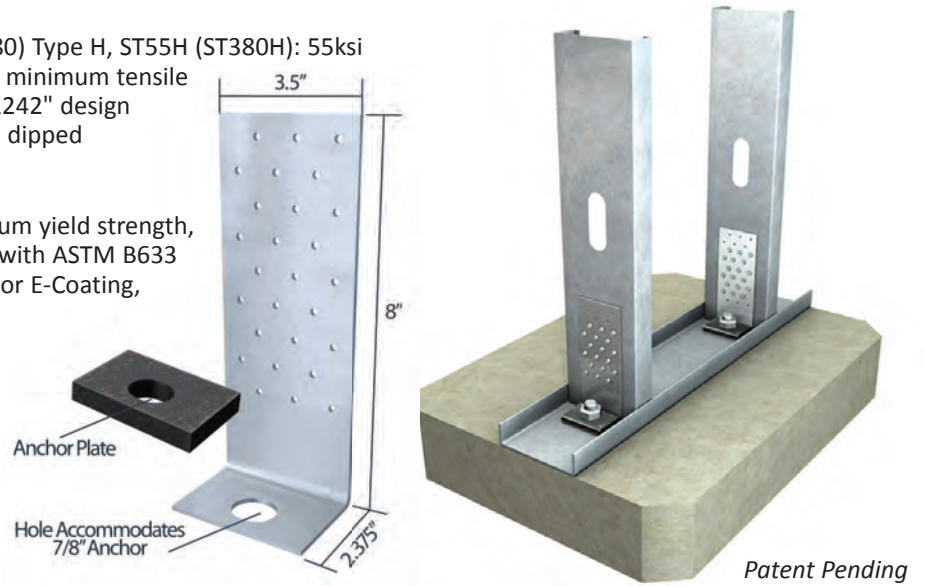

Patent Pending

StiffClip TD Allowable Loads

StiffClip® TD, Recommended Allowable Load for Steel Framing (lbs): F3				
Stud		w/12 #12 Screws	w/18 #12 Screws	w/27 #12 Screws
Thickness Mils (ga)	Yield Strength (ksi)			
33 (20)	33	2,261	3,391	5,087
33 (20)	50	3,266	4,900	7,349
43 (18)	33	3,365	5,047	7,571
43 (18)	50	4,861	7,292	10,718
54 (16)	33	4,732	7,097	10,646
54 (16)	50	6,834	10,251	10,718
68 (14)	50	9,662	10,718	10,718
97 (12)	50	10,188	10,718	10,718
Maximum Allowable Clip Load		10,718		

StiffClip® TD, Recommended Allowable Load for Wood Framing (lbs): F3						
Fastener Type	Douglas Fir / Southern Pine			Spruce Pine-Fir / Hem-Fir		
	Quantity of Fasteners			Quantity of Fasteners		
	12	18	27	12	18	27
10d	2,846	4,268	6,403	2,465	3,698	5,547
16d	3,279	4,919	7,378	2,838	4,257	6,386
#12 Wood Screw	3,451	5,177	7,766	3,046	4,569	6,854
Maximum Allowable Clip Load	10,718			10,718		

Notes:

- Fasten within 1.25" from the angle heel using the existing anchor hole.
- Guide holes are in place for fastener installation efficiency. The number of fasteners are determined by the designer.
- Attachment to stud is made with up to 27 #12 screws, symmetrically placed.
- StiffClip TD resists vertical uplift loads.
- Allowable loads for steel framing have not been increased for wind, seismic, or other factors.
- Allowable shear for nails is increased 60% for wind and seismic loads in wood framing.
- For wood, moisture content > 19%. Consult The Steel Network, Inc. for reductions to values.

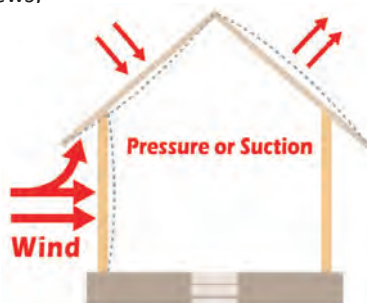

Load Direction

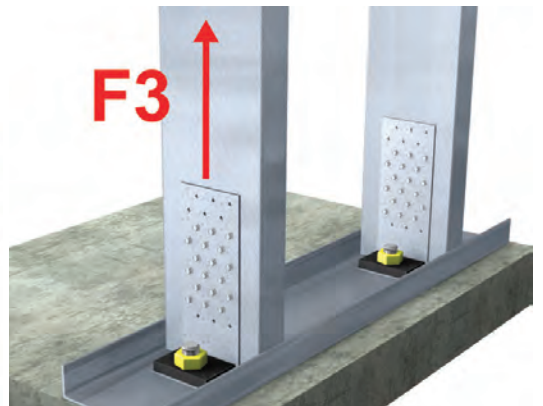

Nomenclature

StiffClip TD is available in one size and utilizes a 0.75" plate on top of the 2.375" leg

Designate: StiffClip® TD

Example Details

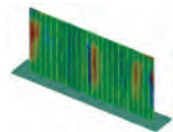
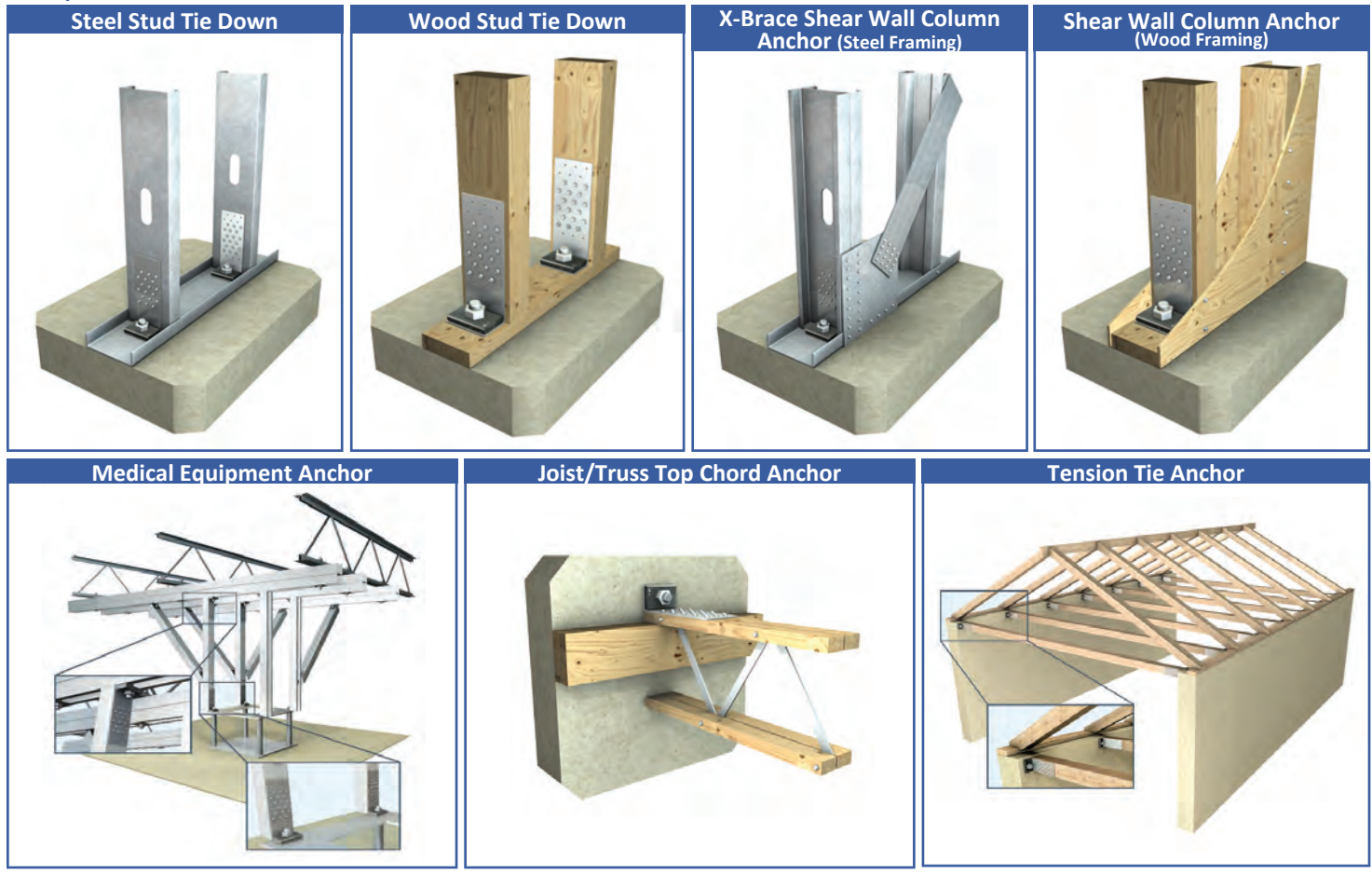

StiffClip TD Series
Blast and Seismic Design Data
www.steelnetwork.com

** For more information or to review a copy of this report, please visit our website at <http://www.steelnetwork.com/Site/TechnicalData>

StiffClip® PLC

Panel Lift Clip

Material Composition

ASTM A1003/A1003M Structural Grade 50 (340) Type H, ST50H (ST340H): 50ksi (340MPa) minimum yield strength, 65ksi (450MPa) minimum tensile strength, 97mil minimum thickness (12 gauge, 0.1017" design thickness) with ASTM A653/A653M G90 (Z275) hot dipped galvanized coating.

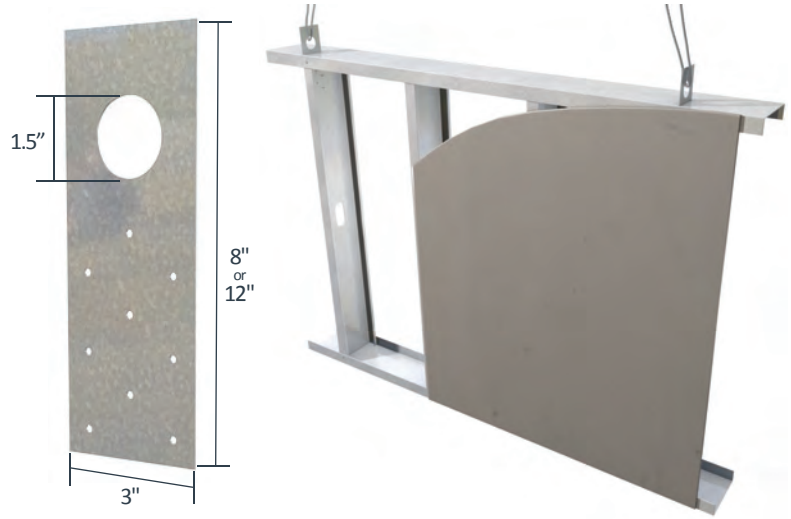

StiffClip PLC Allowable Loads

StiffClip® PLC, Recommended Allowable Load for Steel Framing (lbs): F3 & F2													
Stud		F3						F2					
		PLC-8			PLC-12			PLC-8			PLC-12		
Thickness Mils (ga)	Yield Strength (ksi)	w/3 #10 Screws	w/5 #10 Screws	w/9 #10 Screws	w/5 #10 Screws	w/9 #10 Screws	w/15 #10 Screws	w/3 #10 Screws	w/5 #10 Screws	w/9 #10 Screws	w/5 #10 Screws	w/9 #10 Screws	w/15 #10 Screws
33 (20)	33	531	885	1,593	885	1,593	1,915	126	211	312	182	267	496
33 (20)	50	765	1,275	1,915	1,275	1,915	1,915	181	303	449	263	385	714
43 (18)	33	789	1,315	1,915	1,315	1,915	1,915	187	313	463	271	397	736
43 (18)	50	1,140	1,900	1,915	1,900	1,915	1,915	270	452	669	391	574	1,064
54 (16)	33	1,110	1,850	1,915	1,850	1,915	1,915	263	440	651	381	559	1,036
54 (16)	50	1,602	1,915	1,915	1,915	1,915	1,915	379	635	940	550	806	1,270
68 (14)	50	1,644	1,915	1,915	1,915	1,915	1,915	389	652	964	564	827	1,270
97 (12)	50	1,644	1,915	1,915	1,915	1,915	1,915	389	652	964	564	827	1,270
118 (10)	50	1,644	1,915	1,915	1,915	1,915	1,915	389	652	964	564	827	1,270

Notes:

- Clip F2 allowable load = 1.270 kips based on testing
- Clip F3 allowable load = 1.915 kips based on testing.
- Attachment is made with #10 screws minimum.
- Spacing between clips to be controlled by weight of panel and presence of a spreader bar or a load distribution member

Load Direction

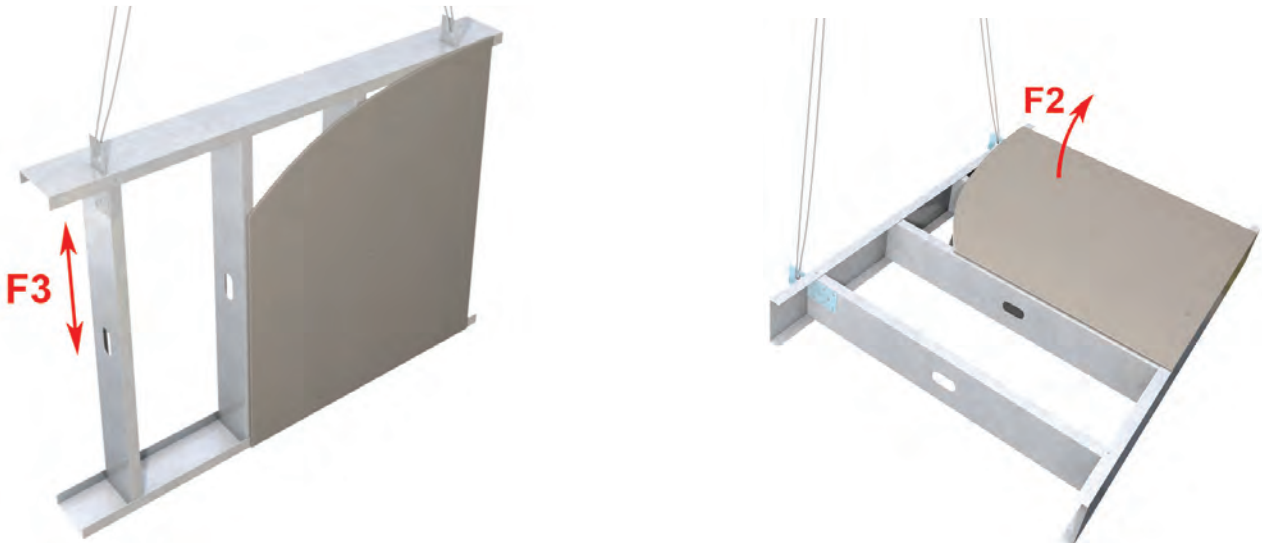

Nomenclature

StiffClip PLC is available in two sizes and is designated by the length of the clip, followed by mil thickness (-97)

Example: 8" Connector

Designate: StiffClip® PLC-8-97

Example Details



Double Attachment to Wall at End Stud



Attachment to Wall at Intermediate Stud



Attachment to Stud Web

StiffClip® HE

Header Connector

Material Composition

HE(L): ASTM A1003/A1003M Structural Grade 50 (340) Type H, ST50H (ST340H): 50ksi (340MPa) minimum yield strength, 65ksi (450MPa) minimum tensile strength, 43mil minimum thickness (18 gauge, 0.0451" design thickness) with ASTM A653/A653M G90 (Z275) hot dipped galvanized coating.

HE(H) & HE(S): ASTM A1003/A1003M Structural Grade 50 (340) Type H, ST50H (ST340H): 50ksi (340MPa) minimum yield strength, 65ksi (450MPa) minimum tensile strength, 68mil minimum thickness (14 gauge, 0.0713" design thickness) with ASTM A653/A653M G90 (Z275) hot dipped galvanized coating.

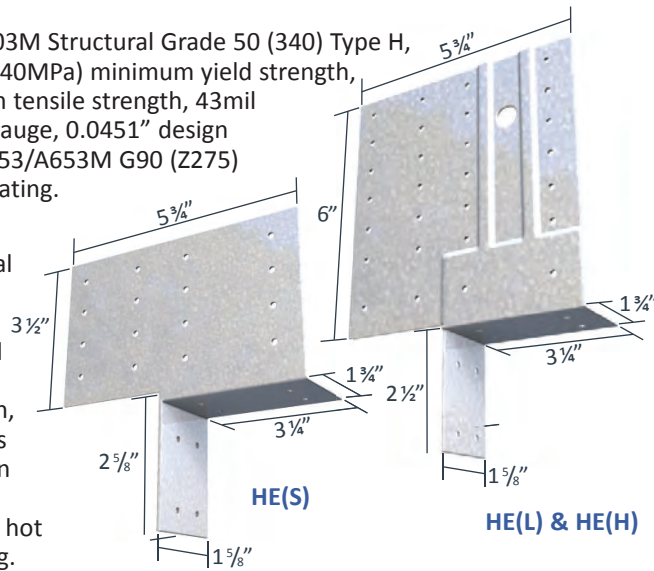

StiffClip HE Allowable Loads for a Single Clip: Screw Fasteners

StiffClip® HE(L) & HE(H): F3 Load Direction (lbs)												
Screw Patterns with #10 Screws	HE(L)						HE(H)					
	8 screws	12 screws	16 screws	20 screws	24 screws	28 screws	8 screws	12 screws	16 screws	20 screws	24 screws	28 screws
33mil (20ga), 33ksi stud	536	708	873	1,090	1,239	1,340	536	708	873	1,090	1,239	1,340
33mil (20ga), 50ksi stud	774	1,021	1,259	1,573	1,787	1,933	774	1,021	1,259	1,573	1,787	1,933
43mil (18ga), 33ksi stud	797	1,052	1,297	1,620	1,841	1,991	797	1,052	1,297	1,620	1,841	1,991
43mil (18ga), 50ksi stud	1,151	1,520	1,873	2,340	2,659	2,876	1,151	1,520	1,873	2,340	2,659	2,876
54mil (16ga), 33ksi stud	1,121	1,480	1,824	2,279	2,590	2,801	1,121	1,480	1,824	2,279	2,590	2,801
54mil (16ga), 50ksi stud	1,518	2,004	2,470	3,066	3,066	3,066	1,618	2,136	2,633	3,289	3,738	4,042
68mil (14ga), 50ksi stud	1,518	2,004	2,470	3,066	3,066	3,066	2,012	2,656	3,274	4,090	4,648	5,026
97mil (12ga), 50ksi stud	1,518	2,004	2,470	3,066	3,066	3,066	2,012	2,656	3,274	4,090	4,648	5,026
Max Allowable Clip Load	3,066						5,545					

StiffClip® HE(S): F3 Load Direction (lbs)			
Screw Patterns with #10 Screws	HE(S)		
	8 screws	12 screws	16 screws
33mil (20ga), 33ksi stud	382	501	611
33mil (20ga), 50ksi stud	551	722	880
43mil (18ga), 33ksi stud	568	744	907
43mil (18ga), 50ksi stud	821	1,075	1,311
54mil (16ga), 33ksi stud	799	1,047	1,276
54mil (16ga), 50ksi stud	1,153	1,511	1,842
68mil (14ga), 50ksi stud	1,434	1,879	2,291
97mil (12ga), 50ksi stud	1,434	1,879	2,291
Max Allowable Clip Load	2,968		

StiffClip® HE(L), HE(H) & HE(S): F2 Load Direction (lbs)					
HE(L)			HE(H) & HE(S)		
4 screws	6 screws	8 screws	4 screws	6 screws	8 screws
199	299	399	199	299	399
287	431	575	287	431	575
296	444	592	296	444	592
428	627	627	428	641	855
417	625	627	417	625	833
564	627	627	601	902	1,088
564	627	627	747	1,088	1,088
564	627	627	747	1,088	1,088
627			1,088		

Notes:

- Torsional effects are considered on screw group for F2 & F3 allowable loads. It is assumed that half of the torsional moment is taken by the connection on one side and half is taken by the connection on the other side of the clip.
- Attachment to stud is made with screws symmetrically placed. All guide holes may not require fasteners. Fastener amount determined by designer.
- Allowable loads have not been increased for wind, seismic, or other factors.
- The minimum combination of steel thickness and yield strength must be used when determining the maximum design load.
- Design loads listed consider both loads on the clip and the #10 screws as they are fastened to the steel beam and column or jamb and header members.

* Refer to screw patterns on the following page.

Load Direction

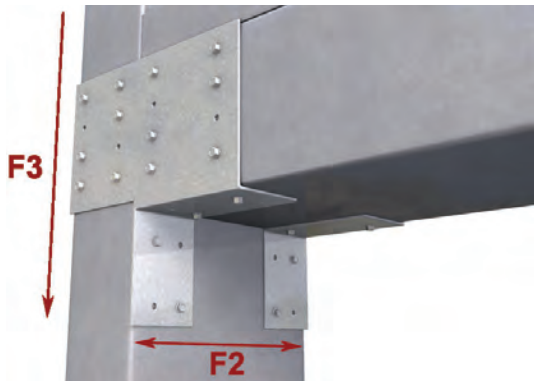

Screw Patterns for HE(L) & HE(H) F3 Load Tables

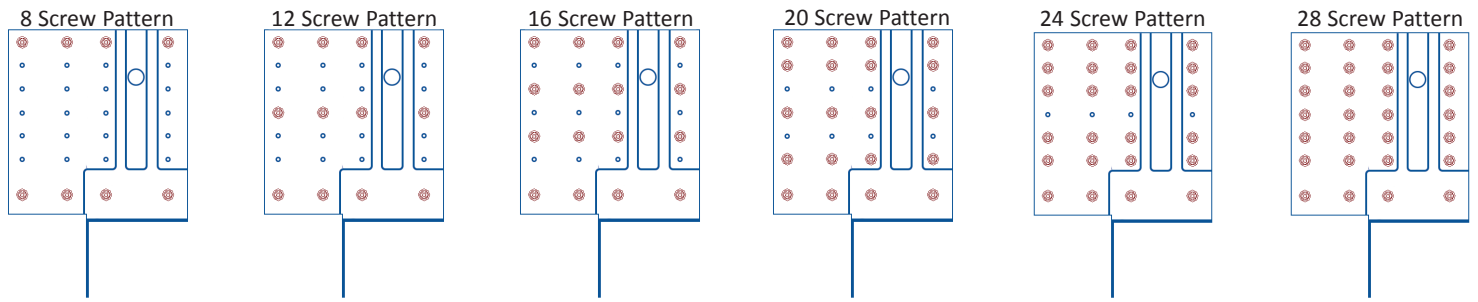

Screw Patterns for HE(S) F3 Load Tables

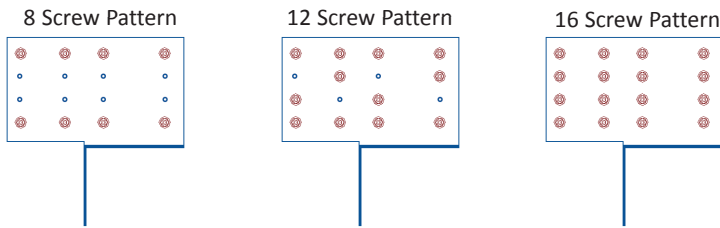

Screw Patterns for F2 Load Tables

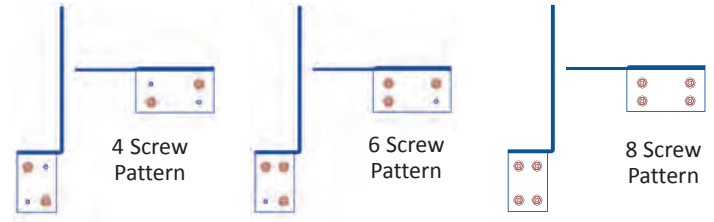

Allowable Loads: Welded Connection

StiffClip® HE Recommended Allowable Load for a Single Clip (lbs): F3		
Stud		HE(H)
Thickness Mils (ga)	Yield Strength (ksi)	Weld used to Header and Post Combined
54 (16) and thicker	50	4,177

Notes:

- The standard StiffClip HE(H) clip does not include all four large holes in the web of the clip. Special orders for these clips can be made by request.
- Allowable F3 welded values do not apply for the 43mil (18ga) StiffClip HE(L)
- StiffClip HE(H) allowable F3 welded values are applicable to clips with welds around the perimeter of the single 1/2" diameter hole, three 3/8" diameter holes, and along each side of the clip. Weld size is not to exceed double the material thickness of the header or jamb, or 1/8". Care should be taken to not burn through the material

Nomenclature

StiffClip HE is available in two thicknesses. The StiffClip HE(L) is 43mil (18ga), and the StiffClip HE(H) & HE(S) are both 68mil (14ga).

* Clips are packaged as pairs. Four StiffClip HE clips are used at each opening: two left-hand and two right-hand clips attach the complete header to the jamb.

Weld Diagram

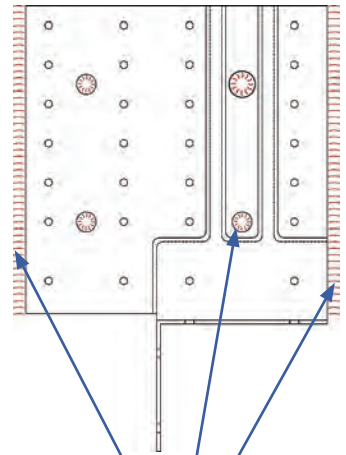

1/8" weld around three 3/8" diameter holes, one 1/2" diameter hole, with 1/8" welds along each side.

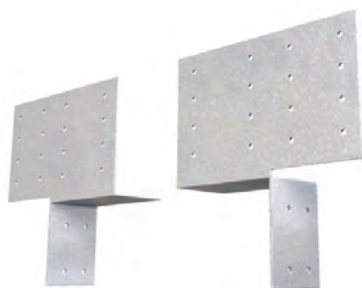

HE(S)



HE(L) & HE(H)

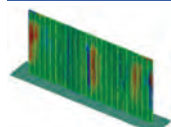

StiffClip HE Series
Blast and Seismic Design Data
www.steelnetwork.com

** For more information or to review a copy of this report, please visit our website at <http://www.steelnetwork.com/Site/TechnicalData>

StiffClip® HS

Jamb Stud Header and Sill Connector

The Steel Network, Inc. 
 www.steelnetwork.com
 1-888-474-4876

Material Composition

ASTM A1003 ST50H, Grade 50 (340MPa) minimum yield strength, 65 ksi (450 Mpa) minimum tensile strength, material thickness = 68mil (14gauge, 0.071" design thickness) G-90 (Z275) hot-dipped galvanized coating.

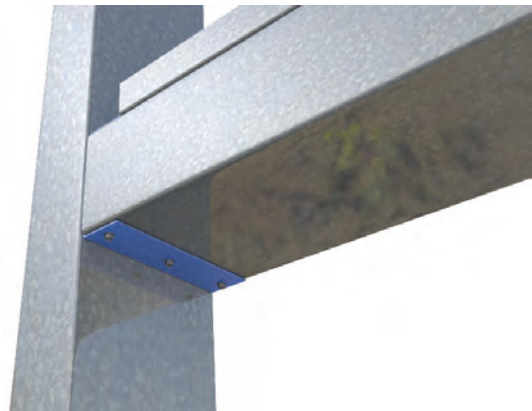
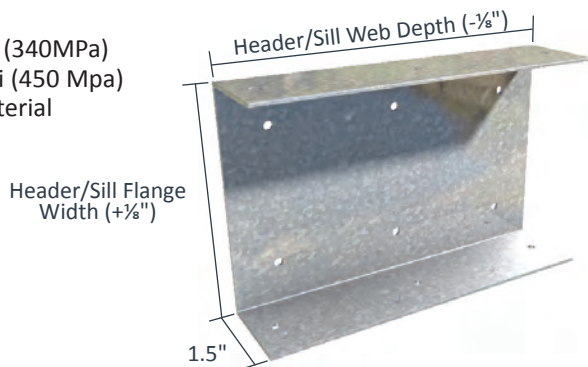

StiffClip HS Allowable Loads

StiffClip® HS Recommended Allowable Load (lbs): F2 & F3							
Header or Jamb		F2 Allowable Loads			F3 Allowable Loads		
		HS362	HS600	HS800	HS362	HS600	HS800
Lesser Thickness Mils (ga)	Yield Strength (ksi)	w/4 #12 screws	w/6 #12 screws	w/6 #12 screws	w/4 #12 screws	w/6 #12 screws	w/6 #12 screws
33 (20)	33	304	561	666	744	1,110	1,130
33 (20)	50	438	810	962	828	1,194	1,488
43 (18)	33	416	779	936	801	1,167	1,461
43 (18)	50	602	1,125	1,353	912	1,278	1,572
54 (16)	33	544	1,028	1,250	865	1,231	1,525
54 (16)	50	786	1,485	1,806	1,003	1,369	1,663
68 (14)	50	1,029	1,964	2,413	1,120	1,486	1,780
97 (12)	50	1,319	2,450	2,927	1,362	1,728	2,022

Load Direction

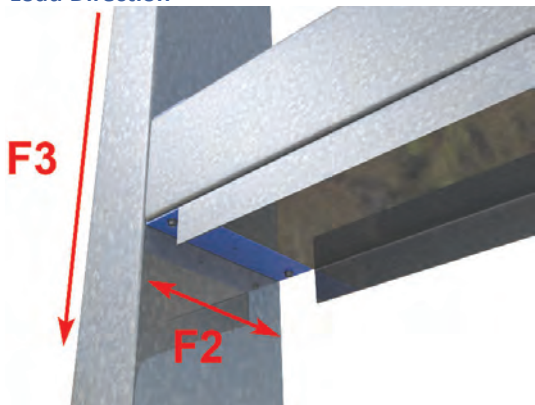

Notes:

- Listed number of screws is for the attachment of clip to jamb. Use minimum (4) #12 screws for the attachment of clip to header or sill
- Up to ¼" gap is allowed between the jamb and the end of the header/sill member
- Allowable loads apply to 250, 300 and 350 flange sizes
- Allowable loads have not been increased for wind, seismic, or other factors

Nomenclature

StiffClip HS is available for attachment to 3 ½", 6", or 8" jambs, and for use with JamStuds with 2 ½", 3" or 3 ½" flanges. To specify, multiply jamb width and header flange width by 100.

Example: 6" jamb and a header flange width of 2 ½"

Designate: StiffClip® HS600-250

Example Details

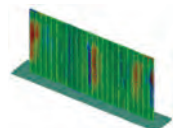

StiffClip HS Series
 Blast and Seismic Design Data
 www.steelnetwork.com

** For more information or to review a copy of this report, please visit our website at <http://www.steelnetwork.com/Site/TechnicalData>

StiffClip® HC

Hip Connector

Material Composition

ASTM A1003/A1003M Structural Grade 50 (340) Type H, ST50H (ST340H): 50ksi (340MPa) minimum yield strength, 65ksi (450MPa) minimum tensile strength, with ASTM A653/A653M G90 (Z275) hot dipped galvanized coating.

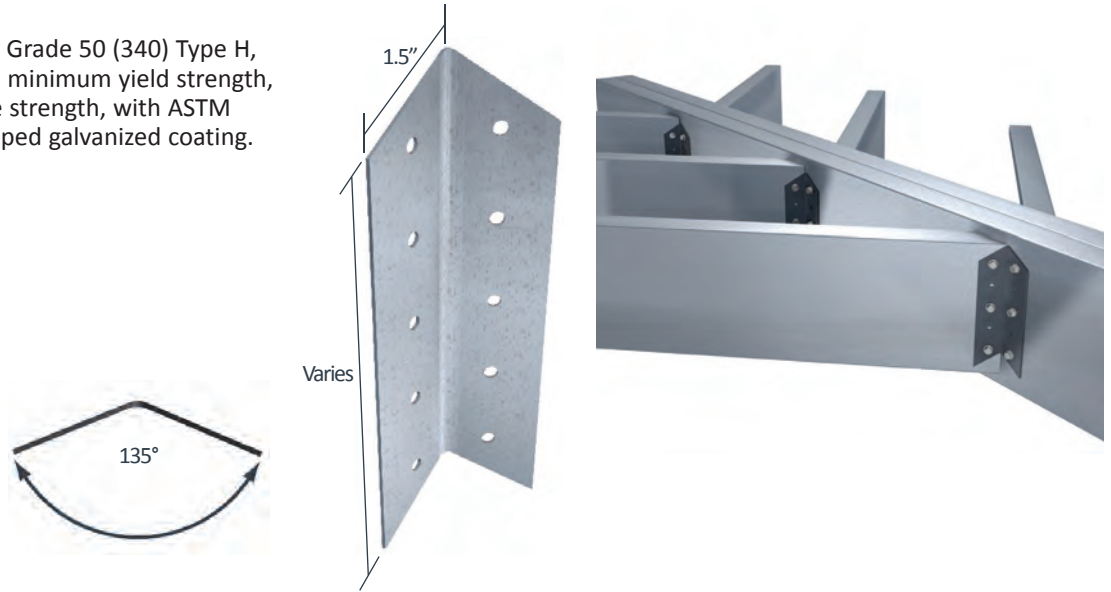

StiffClip HC Allowable Loads

StiffClip® HC Recommended Allowable Load for a Single Clip (lbs): F3									
Joist		HC362/400-43	HC362/400-68	HC600-43	HC600-68	HC800-43	HC800-68	HC1000-68	
Thickness Mils (ga)	Yield Strength (ksi)	w/2 #12 screws	w/2 #12 screws	w/4 # 12 Screws	w/4 # 12 Screws	w/5 # 12 Screws	w/5 # 12 Screws	w/4 # 12 Screws	w/6 # 12 Screws
33 (20)	33	337	337	722	722	910	910	N/A	N/A
33 (20)	50	487	487	1,043	1,043	1,315	1,315	N/A	N/A
43 (18)	33	502	502	1,074	1,074	1,354	1,354	1,102	1,646
43 (18)	50	725	725	1,552	1,552	1,957	1,957	1,592	2,378
54 (16)	33	706	706	1,510	1,510	1,904	1,904	1,550	2,315
54 (16)	50	1,019	1,019	2,158	2,181	2,751	2,751	2,238	3,343
68 (14)	50	1,020	1,441	2,158	3,084	2,753	3,889	3,164	4,727
97 (12)	50	1,020	1,520	2,158	3,252	2,753	4,101	3,337	4,779
Max Allowable Clip Load		1,606	2,302	2,158	3,639	3,960	4,488	4,779	

Joist		HC1200-68		HC1400-68		HC1600-68	
Thickness Mils (ga)	Yield Strength (ksi)	w/6 # 12 Screws	w/8 # 12 Screws	w/5 # 12 Screws	w/9 # 12 Screws	w/6 # 12 Screws	w/10 # 12 Screws
54 (16)	33	2,342	3,111	1,956	3,509	2,346	3,908
54 (16)	50	3,383	4,493	2,825	4,560	3,389	4,560
68 (14)	50	4,560	4,560	3,994	4,560	4,560	4,560
97 (12)	50	4,560	4,560	4,211	4,560	4,560	4,560
Max Allowable Clip Load		4,560		4,560		4,560	

Notes:

- Design loads consider loads on the clip only.
- Number of fasteners used is based on fastener manufacturer’s allowable load data.
- Allowable loads have not been increased for wind, seismic, or other factors.
- All guide holes may not require fasteners. Fastener amount determined by designer.
- Torsional effects are considered on screw groups for F3 allowable loads. It is assumed that half of the torsional moment is taken by the connection to the structure and half is taken by the connection to the stud.

Nomenclature

StiffClip HC is designated by multiplying joist depth by 100, then listing material thickness.

Example: 6” stud depth, 68mil steel thickness

Designate: StiffClip® HC600-68

**Standard angle bend is 135°. Other angle shapes are available.

Load Direction

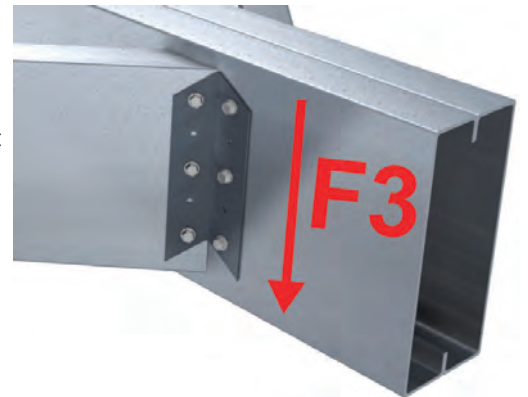

StiffClip® RT

Roof Tie

Material Composition

33 mil & 43 mil thicknesses: ASTM A1003/A1003M Structural Grade 50 (340) Type H, ST50H (ST340H): 50ksi (340MPa) minimum yield strength, 65ksi (450MPa) minimum tensile strength, with ASTM A653/A653M G60 (Z180) hot dipped galvanized coating.

54 mil thickness: ASTM A1003/A1003M Structural Grade 50 (340) Type H, ST50H (ST340H): 50ksi (340MPa) minimum yield strength, 65ksi (450MPa) minimum tensile strength, with ASTM A653/A653M G90 (Z275) hot dipped galvanized coating.

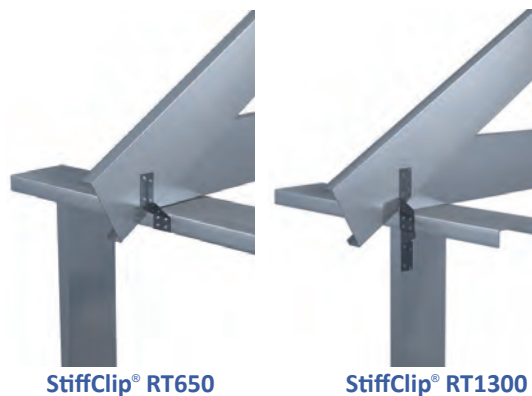
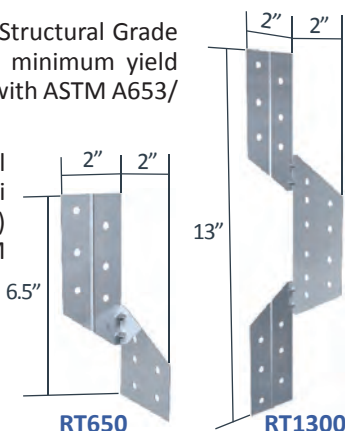

StiffClip RT Allowable Loads

StiffClip® RT, Recommended Allowable Load (lbs): F1							
Stud		RT650-33 & RT1300-33		RT650-43 & RT1300-43		RT650-54 & RT1300-54	
Thickness Mils (ga)	Yield Strength (ksi)	w/2 #12 Screws	w/4 #12 Screws	w/2 #12 Screws	w/4 #12 Screws	w/2 #12 Screws	w/4 #12 Screws
33 (20)	33	94	95	94	95	94	95
33 (20)	50	136	138	136	138	136	138
43 (18)	33	124	124	124	124	124	124
43 (18)	50	175	175	179	179	179	179
54 (16)	33	156	156	156	156	156	156
54 (16)	50	175	175	225	225	225	225
68 (14)	50	175	175	231	231	284	284
97 (12)	50	175	175	231	231	342	342
Maximum Allowable Clip Load		175		231		342	

StiffClip® RT, Recommended Allowable Load (lbs): F2										
Stud		RT650-33	RT650-33 & RT1300-33		RT650-43	RT650-43 & RT1300-43		RT650-54	RT650-54 & RT1300-54	
Thickness Mils (ga)	Yield Strength (ksi)	w/5 #12 Screws in Short Leg	w/2 #12 Screws	w/4 #12 Screws	w/5 #12 Screws in Short Leg	w/2 #12 Screws	w/4 #12 Screws	w/5 #12 Screws in Short Leg	w/2 #12 Screws	w/4 #12 Screws
33 (20)	33	191	95	128	191	95	159	191	95	191
33 (20)	50	239	128	128	275	138	159	275	138	275
43 (18)	33	239	124	128	248	124	159	248	124	248
43 (18)	50	239	128	128	329	159	159	359	179	323
54 (16)	33	239	128	128	312	156	159	312	156	312
54 (16)	50	239	128	128	329	159	159	450	225	323
68 (14)	50	239	128	128	329	159	159	567	284	323
97 (12)	50	239	128	128	329	159	159	614	323	323
Max Allowable Clip Load		239	128		329	159		614	323	

****StiffClip RT Allowable Load tables and important notes continued on next page.**

StiffClip® RT, Recommended Allowable Load (lbs): F3							
Stud		RT650-33 & RT1300-33		RT650-43 & RT1300-43		RT650-54 & RT1300-54	
Thickness Mils (ga)	Yield Strength (ksi)	w/2 #12 Screws	w/4 #12 Screws	w/2 #12 Screws	w/4 #12 Screws	w/2 #12 Screws	w/4 #12 Screws
33 (20)	33	198	384	198	384	198	384
33 (20)	50	286	453	286	537	286	555
43 (18)	33	294	453	294	537	294	572
43 (18)	50	425	453	425	537	425	826
54 (16)	33	414	453	414	537	414	804
54 (16)	50	453	453	537	537	598	1,024
68 (14)	50	453	453	537	537	751	1,024
97 (12)	50	453	453	537	537	751	1,024
Maximum Allowable Clip Load		453		537		1,024	

Notes:

- StiffClip RT resists horizontal, lateral, and uplift loads.
- Allowable loads have not been increased for wind, seismic, or other factors.
- Number of screws designated represents the amount required in each leg of the clip.
- Loads listed reflect force in a single direction. When multiple loads act on the connection, it is the responsibility of the designer to check the interaction of forces.
- Torsional effects are considered on screw groups for F1, F2 & F3 allowable loads. It is assumed that half of the torsional moment is taken by the connection to the structure and half is taken by the connection to the stud.

Load Direction

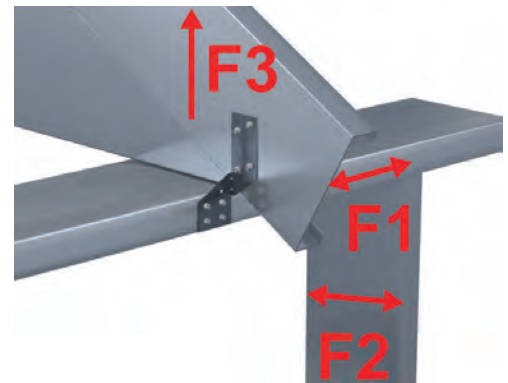

Nomenclature

StiffClip RT650 is 6½” long, and may be used when wall studs do not align with roof framing member. The RT1300 is 13” long, and is used when wall studs align with roof framing member. Clips are designated by length, followed by thickness and number of screws used in each leg (determined by load requirements - refer to load tables).

Example: Stud aligns with roof framing member (see application image)

Designate: StiffClip® 1300

* StiffClip RT650 are packaged in pairs.



StiffClip® WC

Web Connector

Material Composition

54mil: ASTM A1003/A1003M Structural Grade 50 (340) Type H, ST50H (ST340H): 50ksi (340MPa) minimum yield strength, 65ksi (450MPa) minimum tensile strength, 54mil minimum thickness (16 gauge, 0.0566" design thickness) with ASTM A653/A653M G90 (Z275) hot dipped galvanized coating.

118mil: ASTM A1003/A1003M Structural Grade 50 (340) Type H, ST50H (ST340H): 50ksi (340MPa) minimum yield strength, 65ksi (450MPa) minimum tensile strength, 118mil minimum thickness (10 gauge, 0.1242" design thickness) with ASTM A653/A653M G90 (Z275) hot dipped galvanized coating.

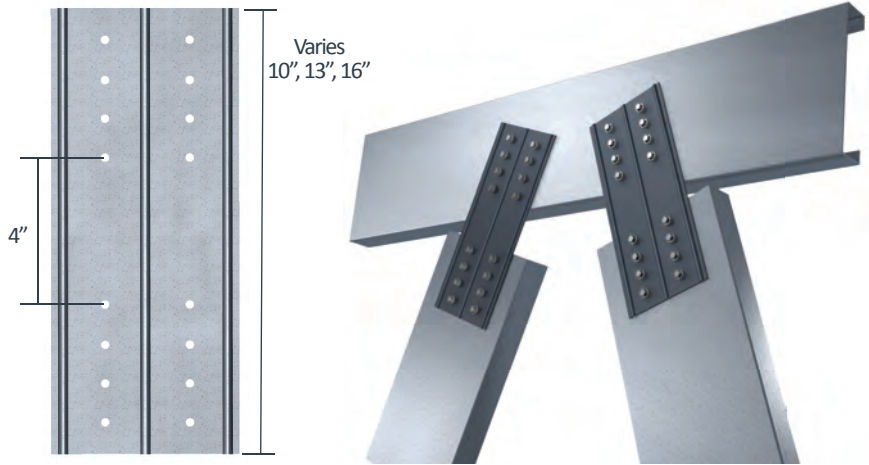

StiffClip WC Allowable Loads (lbs)

Screw Patterns with #12 Screw	WC350-54, 10" lg				WC350-118, 10"lg				WC550-54, 13"lg			
	2 Screws	4 Screws	6 Screws	8 Screws	2 Screws	4 Screws	6 Screws	8 Screws	4 Screws	6 Screws	8 Screws	10 Screws
33mil (20ga), 33ksi stud	104	153	248	1,300	376	752	1,128	1,504	118	184	327	737
33mil (20ga), 50ksi stud	104	153	248	1,300	544	1,088	1,632	2,176	118	184	327	737
43mil (18ga), 33ksi stud	104	153	248	1,300	560	1,120	1,680	2,240	118	184	327	737
43mil (18ga), 50ksi stud	104	153	248	1,300	810	1,618	2,430	3,240	118	184	327	737
54mil (16ga), 33ksi stud	104	153	248	1,300	788	1,576	2,364	3,152	118	184	327	737
54mil (16ga), 50ksi stud	104	153	248	1,300	1,097	1,618	2,620	4,552	118	184	327	737
68mil (14ga), 50ksi stud	104	153	248	1,300	1,097	1,618	2,620	4,936	118	184	327	737
97mil (12ga), 50ksi stud												
Max Allowable Clip Load (lbs)	1,300*				4,936**				737**			

Stud	WC550-118, 13" lg				WC750-54, 16"lg					WC750-118, 16"lg				
	4 Screws	6 Screws	8 Screws	10 Screws	4 Screws	6 Screws	8 Screws	10 Screws	12 Screws	4 Screws	6 Screws	8 Screws	10 Screws	12 Screws
33mil (20ga), 33ksi stud	752	1,128	1,504	1,880	112	161	251	447	1,005	752	1,128	1,504	1,880	2,256
33mil (20ga), 50ksi stud	1,088	1,632	2,176	2,720	112	161	251	447	1,005	1,088	1,632	2,176	2,720	3,264
43mil (18ga), 33ksi stud	1,120	1,680	2,240	2,800	112	161	251	447	1,005	1,120	1,680	2,240	2,800	3,360
43mil (18ga), 50ksi stud	1,246	1,946	3,240	4,050	112	161	251	447	1,005	1,180	1,699	2,654	4,050	4,860
54mil (16ga), 33ksi stud	1,246	1,946	3,152	3,940	112	161	251	447	1,005	1,180	1,699	2,654	3,940	4,728
54mil (16ga), 50ksi stud	1,246	1,946	3,460	5,690	112	161	251	447	1,005	1,180	1,699	2,654	4,718	6,828
68mil (14ga), 50ksi stud	1,246	1,946	3,460	7,756	112	161	251	447	1,005	1,180	1,699	2,654	4,718	9,324
97mil (12ga), 50ksi stud														
Max Allowable Clip Load (lbs)	7,756**				1,005**					10,576**				

Table Notes:

- Allowable design loads apply to tension and compression on StiffClip WC utilizing the fastener patterns shown on next page.
- Allowable loads have not been increased for wind, seismic, or other factors.
- All guide holes may not require fasteners. Number and size of fasteners used is based on fastener manufacturer's allowable load data, and is to be determined by designer.

* Load based on structural test.
 ** Load based on calculations.

Load Direction



***StiffClip WC Screw Patterns are shown on next page.

Screw Patterns

WC350-54

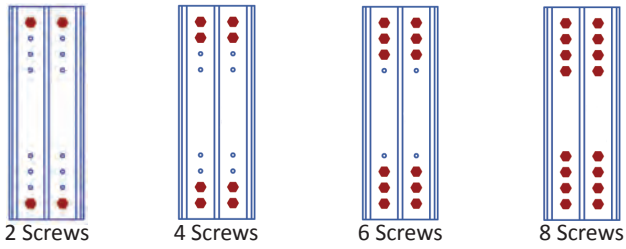

WC350-118

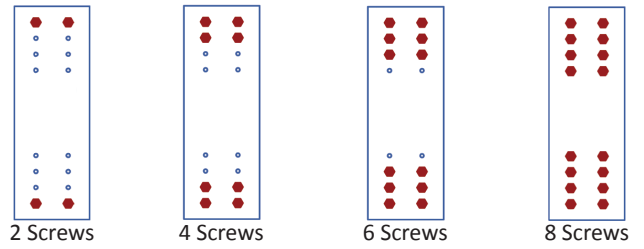

WC550-XX

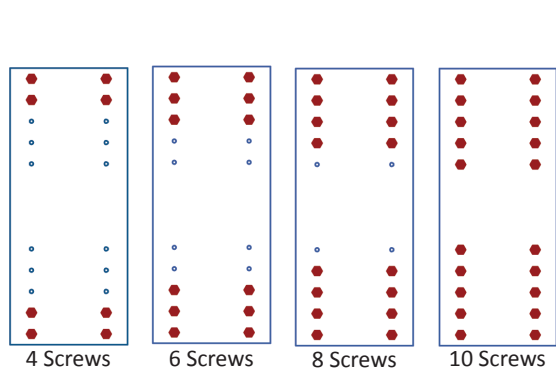

WC750-XX

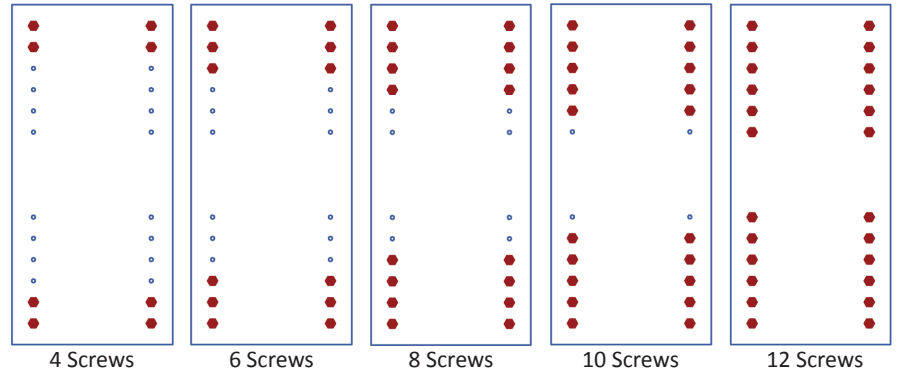

Nomenclature

StiffClip WC is designated by multiplying stud depth in inches by 100, then listing material, thickness and length.

Example: 3½" stud depth, 54mil steel thickness, 10" long

Designate: StiffClip® WC350-54 10"

Example Details



StiffClip® PL

Truss Plate Connector

The Steel Network, Inc. 
 www.steelnetwork.com
 1-888-474-4876

Material Composition

ASTM A1003/A1003M Structural Grade 50 (340) Type H, ST50H (ST340H): 50ksi (340MPa) minimum yield strength, 65ksi (450MPa) minimum tensile strength, with ASTM A653/A653M G90 (Z275) hot dipped galvanized coating.



StiffClip PL Allowable Loads

Plates used to connect framing are generally considered as pinned joints. Load transfers through screw or welded connections between members.

Notes:

- All guide holes may not require fasteners. Number and size of fasteners used is based on fastener manufacturer's allowable load data, and is to be determined by designer.
- Guide holes are 0.172" in diameter unless specified.
- Guide holes have ½" minimum edge distance and 1" minimum spacing. Spacing will vary based on plate size and specified project requirements.

Nomenclature

StiffClip PL is available in many different shapes and is designated as width x length - material thickness.

Example: 10" wide x 24" long with 68 mil thickness

Designate: StiffClip® PL10x24-68

* Clip sizes vary within each application

**StiffClip PL are typically made to order per project specifications.

Load Direction

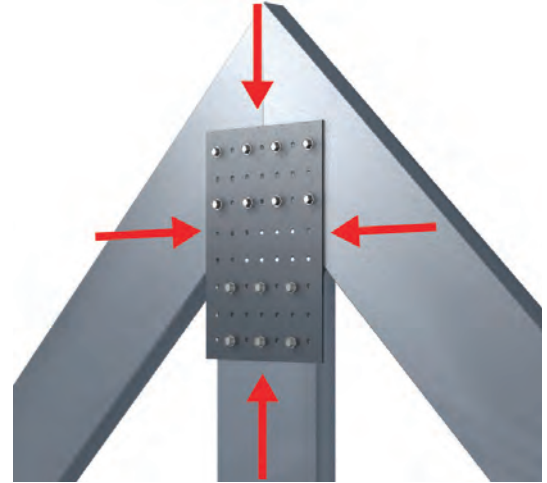

Example Details

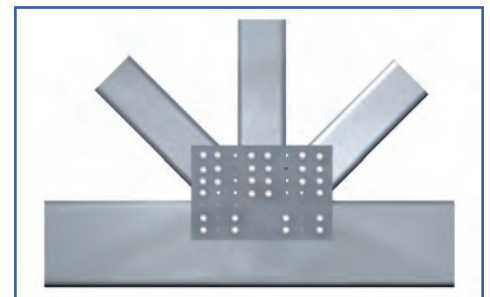
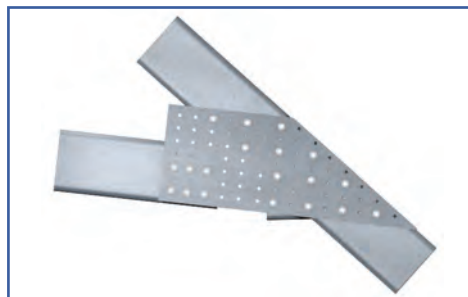
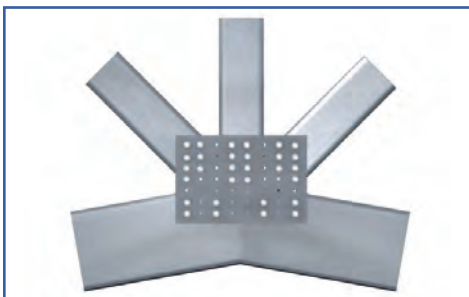
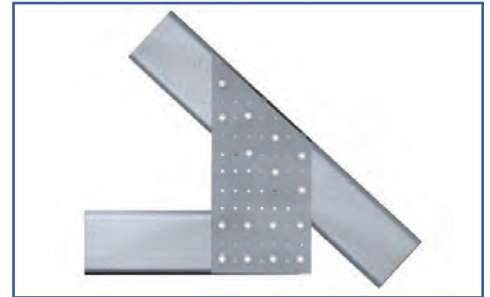
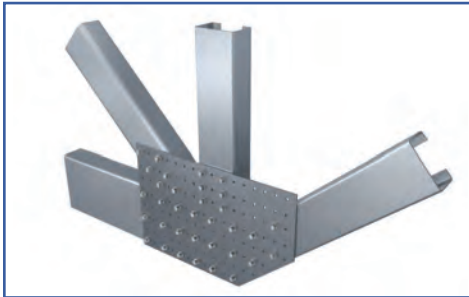

StiffClip® JH

Joist Hanger

Material Composition

ASTM A1003/A1003M Structural Grade 50 (340) Type H, ST50H (ST340H): 50ksi (340MPa) minimum yield strength, 65ksi (450MPa) minimum tensile strength, with ASTM A653/A653M G90 (Z275) hot dipped galvanized coating.

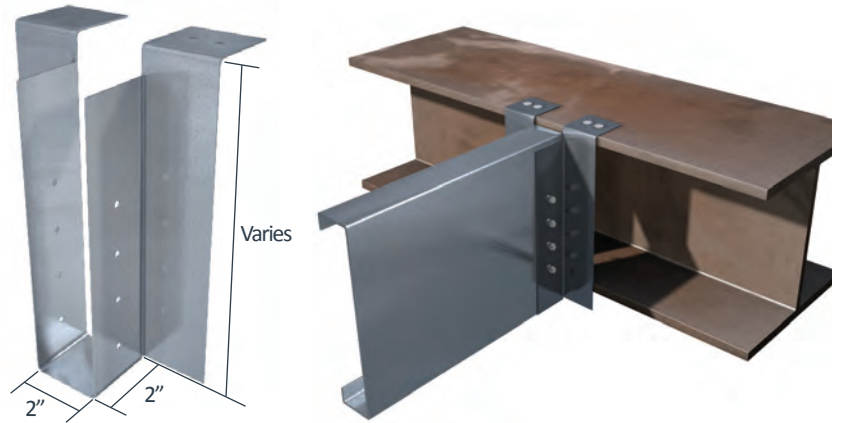

StiffClip JH Allowable Loads

StiffClip® JH Recommended Allowable Load (lbs): F3							
Joist		JH600-68	JH800-68	JH1000-68	JH1000-97	JH1200-68	JH1200-97
Thickness Mils (ga)	Yield Strength (ksi)	w/2 #12 screws	w/3 #12 screws	w/4 #12 screws	w/4 #12 screws	w/5 #12 screws	w/5 #12 screws
33 (20)	33	638	474	N/A	N/A	N/A	N/A
33 (20)	50	644	478	N/A	N/A	N/A	N/A
43 (18)	33	1,416	1,051	836	836	N/A	N/A
43 (18)	50	1,433	1,060	842	842	N/A	N/A
54 (16)	33	2,575	2,091	1,661	1,661	1,377	1,377
54 (16)	50	2,575	2,091	1,661	1,661	1,377	1,377
68 (14)	50	2,575	2,575	2,575	3,345	2,575	2,771
97 (12)	50	2,575	2,575	2,575	4,167	2,575	4,167
118 (10)	50	2,575	2,575	2,575	4,167	2,575	4,167
Max Allowable Clip Load		2,575	2,575	2,575	4,167	2,575	4,167

Notes:

- Screw size and quantity shown is required for JH to serve as web stiffener.
- Design loads based on clip capacity and allowable shear in joist. Allowable loads have not been increased for wind, seismic, or other factors.
- If beam web is larger than clip length, use blocking behind clip for support.
- StiffClip JH resists vertical loads and web crippling.
- Screws, powder-actuated fasteners, or weld attachment may be used to connect StiffClip JH to the steel header/beam. StiffClip JH 68mil and heavier can be welded to the steel beam. Powder-actuated fasteners into steel are recommended to be 0.157" diameter, and are limited to a maximum of 3/4" substrate thick.

Nomenclature

StiffClip JH is designated by listing the joist depth in inches, followed by the inside flange dimension in inches x 100 (2" flange is standard, and will also service 1 5/8" flange), and the required clip thickness in mils that will accommodate anticipated loads. (see load tables)

Example: 6" joist, 2" flange, 2,250 lbs. load
Designate: StiffClip® JH600x200-68



Load Direction

StiffClip® JC

Joist Connector

The Steel Network, Inc. 
 www.steelnetwork.com
 1-888-474-4876

Material Composition

ASTM A1003/A1003M Structural Grade 50 (340) Type H, ST50H (ST340H): 50ksi (340MPa) minimum yield strength, 65ksi (450MPa) minimum tensile strength, with ASTM A653/A653M G90 (Z275) hot dipped galvanized coating.

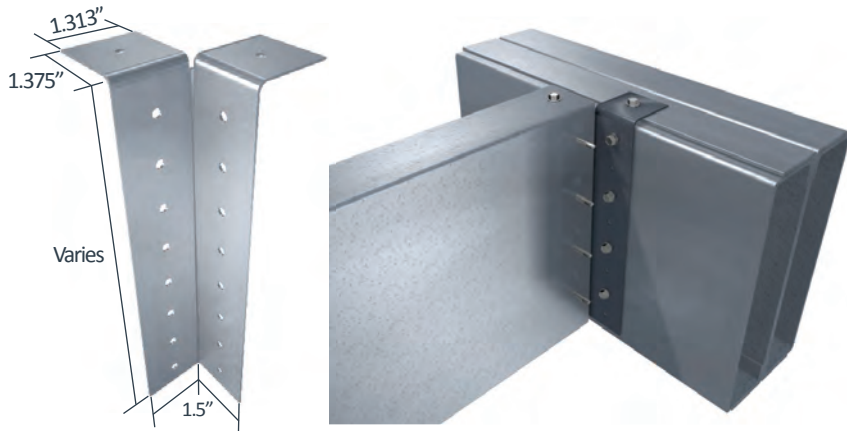

StiffClip JC Allowable Loads

StiffClip® JC Recommended Allowable Load (lbs): F3													
Joist		JC362/400-43	JC362/400-68	JC600-43		JC600-68		JC800-43		JC800-68		JC1000-68	
Thickness Mils (ga)	Yield Strength (ksi)	w/3 #12 screws	w/3 #12 screws	w/3 #12 screws	w/5 #12 screws	w/3 #12 screws	w/5 #12 screws	w/4 #12 screws	w/7 #12 screws	w/4 #12 screws	w/7 #12 screws	w/5 #12 screws	w/9 #12 screws
33 (20)	33	492	492	544	882	544	882	735	1,270	735	1,270	N/A	N/A
33 (20)	50	710	710	787	1,274	787	1,274	1,062	1,835	1,062	1,835	N/A	N/A
43 (18)	33	732	732	810	1,312	810	1,312	1,094	1,890	1,094	1,890	1,377	2,462
43 (18)	50	1,057	1,057	1,171	1,896	1,171	1,896	1,580	2,730	1,580	2,730	1,989	3,557
54 (16)	33	1,029	1,029	1,140	1,845	1,140	1,845	1,538	2,658	1,538	2,658	1,936	3,462
54 (16)	50	1,486	1,486	1,646	2,158	1,646	2,665	2,221	3,838	2,221	3,838	2,796	4,779
68 (14)	50	1,487	2,102	1,647	2,158	2,327	3,639	2,223	3,841	3,140	4,488	3,954	4,779
97 (12)	50	1,487	2,216	1,647	2,158	2,454	3,639	2,223	3,841	3,311	4,488	4,169	4,779
Max Allowable Clip Load		1,606	2,302	2,158		3,639		3,960		4,488		4,779	

StiffClip® JC Recommended Allowable Load (lbs): F3							
Joist		JC1200-68		JC1400-68		JC1600-68	
Thickness Mils (ga)	Yield Strength (ksi)	w/6 #12 screws	w/11 #12 screws	w/7 #12 screws	w/13 #12 screws	w/8 #12 screws	w/15 #12 screws
54 (16)	33	2,334	4,262	2,732	5,063	3,131	5,855
54 (16)	50	3,371	6,156	3,947	6,670	4,522	6,670
68 (14)	50	4,467	6,670	5,580	6,670	6,393	6,670
97 (12)	50	5,026	6,670	5,884	6,670	6,670	6,670
Max Allowable Clip Load		6,670		6,670		6,670	

Notes:

- StiffClip JC resists vertical loads.
- The attachment to the beam or structure must be designed to be greater than or equivalent to the joist attachment.
- Design loads consider clip capacity and screw connection to the joist only.
- Allowable loads have not been increased for wind, seismic, or other factors.
- All guide holes may not require fasteners. Fastener size and amount determined by designer.
- Torsional effects are considered on screw group for F3 allowable loads. It is assumed that half of the torsional moment is taken by the connection to the structure and half is taken by the connection to the stud, i.e. ½ in the joist connection and ½ in the structure connection.

Nomenclature

StiffClip JC is designated by listing the joist depth in inches, followed by the required clip thickness in mils that will accommodate anticipated loads. (see load tables above)

Example: 6" joist, 3,000 lbs. load
Designate: StiffClip® JC600-68

Load Direction

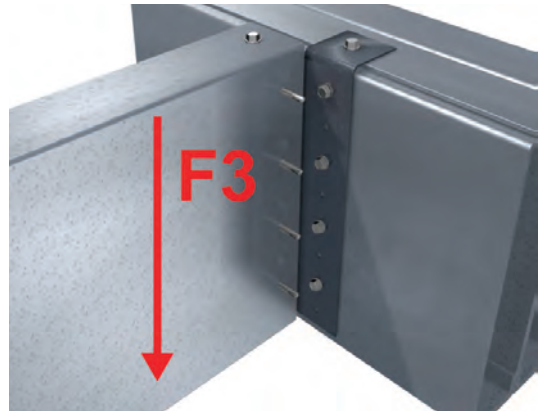

StiffClip® FS

Floor Strap

Material Composition

ASTM A1003/A1003M Structural Grade 50 (340) Type H, ST50H (ST340H): 50ksi (340MPa) minimum yield strength, 65ksi (450MPa) minimum tensile strength, with ASTM A653/A653M G90 (Z275) hot dipped galvanized coating.

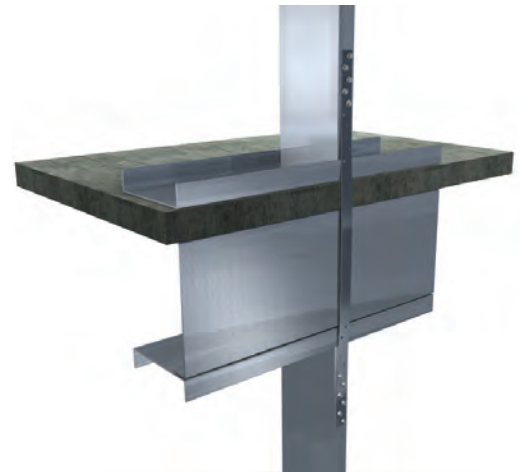

StiffClip FS Allowable Loads

StiffClip® FS Recommended Allowable Load (lbs): F3	
Designation	Load
FS125-33	1,163
FS125-43	1,516
FS125-54	1,902
FS125-68	2,396
FS125-97	3,418
FS275-33	2,849
FS275-43	3,713
FS275-54	4,660
FS275-68	5,871
FS275-97	8,374

Load Direction

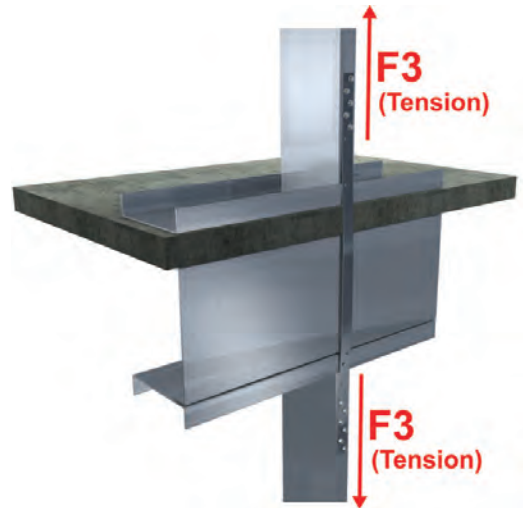

Notes:

- StiffClip FS resists tension forces only.
- Design loads based on strap capacity only.
- Allowable loads have not been increased for wind, seismic, or other factors.
- Number of fasteners used is based on fastener manufacturer's allowable load data.
- Guide holes located 1/2" from each end, with 3/8" edge distance at 2" o.c. staggered for FS125 and 3/4" edge distance at 2" o.c. staggered for FS275.

Nomenclature

StiffClip FS is designated by the width of the strap in inches followed by strap thickness in mils.

Example: 16ga, 2 3/4" strap, 24" long

Designate: StiffClip® FS275-54-24

* Additional guide holes for fasteners available upon request.

**StiffClip FS are typically made to order per project specifications.

StiffClip® AL

Multi-Directional Load Resistant Angle

Material Composition

ASTM A1003/A1003M Structural Grade 50 (340) Type H, ST50H (ST340H): 50ksi (340MPa) minimum yield strength, 65ksi (450MPa) minimum tensile strength, 68mil minimum thickness (14 gauge, 0.0713" design thickness) with ASTM A653/A653M G90 (Z275) hot dipped galvanized coating.

The attachment of StiffClip to the primary structure may be made with PAFs, screw/bolt anchors or weld and is dependent upon the base material (steel or concrete) and the design configuration.

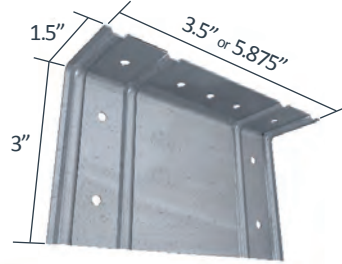

AL362 & AL600

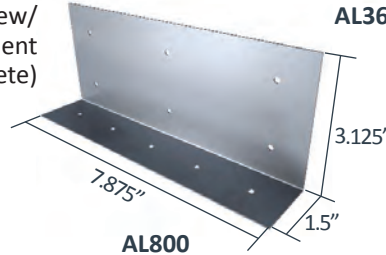

AL800

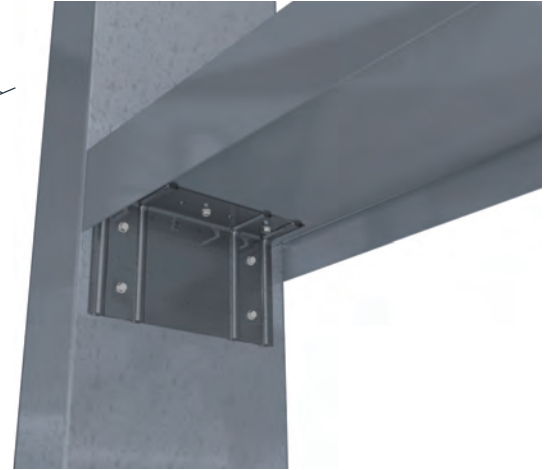

StiffClip AL Allowable Loads

StiffClip® AL, Recommended Allowable Load (lbs): F1 & F2													
Stud		F1 Load Direction					F2 Load Direction						
Thickness Mils (ga)	Yield Strength (ksi)	AL362			AL600		AL362			AL600		AL800	
		w/3 #12 Screws	w/3 #12 Screws	w/4 #12 Screws	w/2 #12 Screws	w/3 #12 Screws	w/4 #12 Screws	w/2 #12 Screws	w/3 #12 Screws	w/4 #12 Screws	w/2 #12 Screws	w/4 #12 Screws	w/6 #12 Screws
33 (20)	33	191	191	191	377	490	754	377	463	752	377	754	1,131
33 (20)	50	275	275	275	544	708	1,089	544	670	1,089	544	1,089	1,633
43 (18)	33	248	248	248	561	729	1,122	560	690	1,120	561	1,122	1,683
43 (18)	50	359	359	359	810	1,053	1,470	810	997	1,620	810	1,620	2,430
54 (16)	33	312	312	312	789	1,025	1,470	788	970	1,577	789	1,577	2,366
54 (16)	50	450	450	450	1,139	1,470	1,470	1,138	1,401	2,091	1,139	2,278	2,516
68 (14)	50	567	567	567	1,470	1,470	1,470	1,610	1,981	2,091	1,610	2,516	2,516
97 (12)	50	809	809	809	1,470	1,470	1,470	1,698	2,089	2,091	1,698	2,516	2,516
118 (10)	50	856	856	856	1,470	1,470	1,470	1,698	2,089	2,091	1,698	2,516	2,516
Max Allowable Clip Load		975	866	1,768	1,470			2,091			2,516		

StiffClip® AL, Recommended Allowable Load (lbs): F3										
Stud		F3 Load Direction								
Thickness Mils (ga)	Yield Strength (ksi)	AL362			AL600			AL800		
		w/2 #12 Screws	w/3 #12 Screws	w/4 #12 Screws	w/2 #12 Screws	w/3 #12 Screws	w/4 #12 Screws	w/2 #12 Screws	w/4 #12 Screws	w/6 #12 Screws
33 (20)	33	256	409	511	324	495	650	347	692	987
33 (20)	50	370	591	738	468	716	939	501	999	1,426
43 (18)	33	381	609	760	482	737	967	516	1,029	1,469
43 (18)	50	551	879	1,098	697	1,065	1,398	745	1,487	2,123
54 (16)	33	536	856	1,069	678	1,037	1,360	726	1,447	2,066
54 (16)	50	775	1,236	1,543	980	1,498	1,965	1,048	2,090	2,984
68 (14)	50	1,095	1,747	2,182	1,385	2,118	2,778	1,482	2,955	4,219
97 (12)	50	1,155	1,842	2,301	1,460	2,233	2,929	1,562	3,116	4,449
118 (10)	50	1,155	1,842	2,301	1,460	2,233	2,929	1,562	3,116	4,449
Maximum Allowable Clip Load		2,458			3,015			6,128		

Load Direction

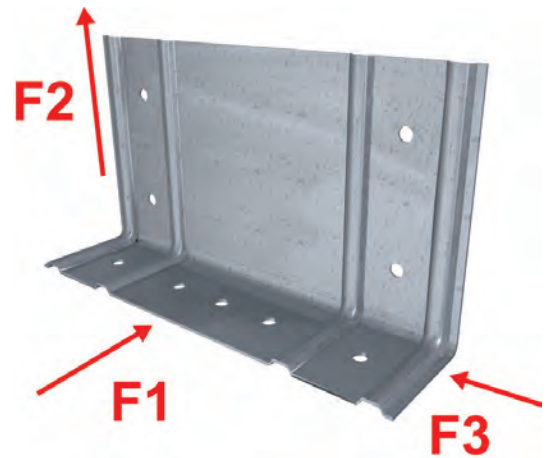

****Important notes for StiffClip AL Allowable Load tables continued on next page.**

Notes:

- Allowable load tables incorporate eccentric loading of fasteners attached 3/4" from the heel of the clip. Values with welded connection may increase.
- The attachment of the 1.5" leg of StiffClip AL is dependent on the allowable loads of the fasteners, and is to be designed by others.
- Fasten within 3/4" from the angle heel (centerline of the 1 1/2" leg).
- All guide holes may not require fasteners. Number of fasteners used is to be determined by designer.
- Stiffening ribs are not present in the AL800.
- StiffClip AL is tested to resist loads in horizontal, vertical, and lateral directions.
- Loads listed reflect force in a single direction. When multiple loads react on the connection, it is the responsibility of the designer to check the interaction of forces.
- Allowable loads are for attachment through 3" leg only. Attachment through 1.5" leg should be engineered. (See material composition above for calculation purposes.)
- Allowable loads have not been increased for wind, seismic, or other factors.
- Torsional effects are considered on screw group for F2 & F3 allowable loads. It is assumed that half of the torsional moment is taken by the connection to the structure and half is taken by the connection to the stud.

Screw Patterns

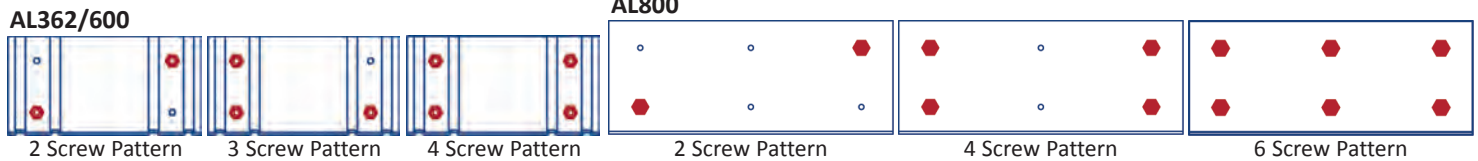

Nomenclature

StiffClip AL is available for various stud depths. To specify, multiply stud depth by 100.*

Example: 6" stud depth

Designate: StiffClip® AL600

* The AL362 fits 3 5/8" and 4" member depths

** Stiffening ribs are not present in the AL800.

Example Details

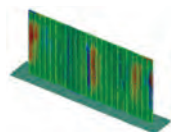
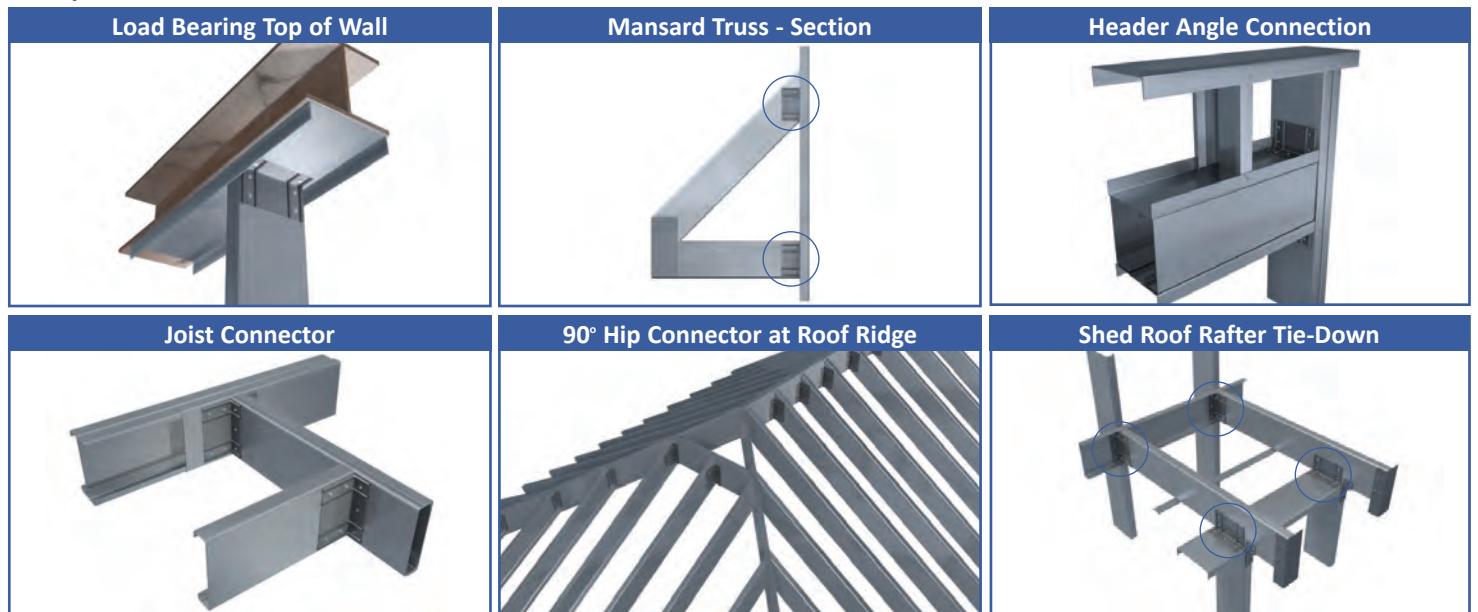

StiffClip AL Series
Blast and Seismic Design Data
www.steelnetwork.com

** For more information or to review a copy of this report, please visit our website at <http://www.steelnetwork.com/Site/TechnicalData>

StiffClip® LS

Spandrel/Multi-Purpose



Material Composition

ASTM A1003/A1003M Structural Grade 50 (340) Type H, ST50H (ST340H): 50ksi (340MPa) minimum yield strength, 65ksi (450MPa) minimum tensile strength, 68mil minimum thickness (14 gauge, 0.0713" design thickness) with ASTM A653/A653M G90 (Z275) hot dipped galvanized coating.

The attachment of StiffClip to the primary structure may be made with PAFs, screw/bolt anchors or weld and is dependent upon the base material (steel or concrete) and the design configuration.

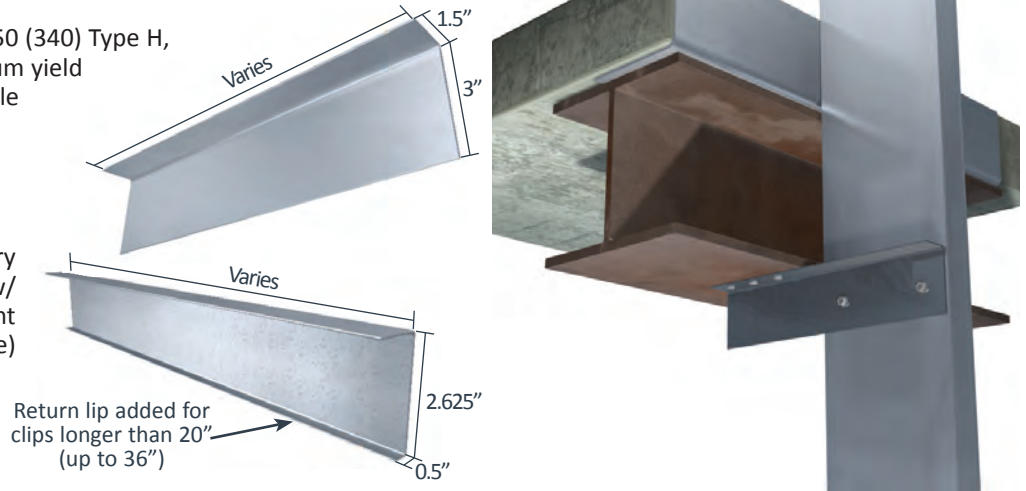

Material Analysis

StiffClip® LS Section Properties							
Designation	Area (in ²)	I _x (in ⁴)	I _y (in ⁴)	R _x (in)*	R _y (in)**	S _x (in ³)	S _y (in ³)
StiffClip® LS < 20" Length	0.325	0.344	0.057	1.030	0.418	0.169	0.046
StiffClip® LS > 20" Length	0.320	0.298	0.055	0.965	0.415	0.186	0.046

Notes:

- For PAFs, fasten within 3/4" from the angle heel centerline of the 1 1/2" leg.
- StiffClip LS resists axial tension and compression loads.
- Allowable design loads may be calculated based on the section properties shown above.
- Lengths greater than 20" incorporate a stiffening lip to increase compressive strength.

* R_x = Radius of Gyration about x-x axis

** R_y = Radius of Gyration about y-y axis

Nomenclature

StiffClip LS is available in various lengths. To calculate length for spandrel wall connectors, add stud depth, 3" for attachment to steel (5.5" for attachment to concrete), and the distance of construction tolerance. For other applications, simply designate length (in.) multiplied by 100.

Example: 6" stud depth, 4" attachment to structure, 2" tolerance (6+4+2=12)

Designate: StiffClip® LS1200

Example Details

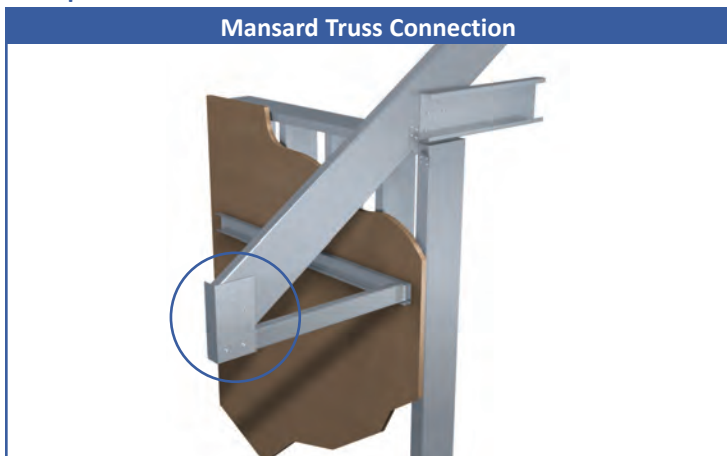

CircleTrak®

Curved Wall Track

Material Composition

ASTM A1003/A1003M Structural Grade 33 (230) Type H, ST33H (ST230H): 33ksi (230MPa) minimum yield strength, 45ksi (310MPa) minimum tensile strength, 33mil minimum thickness (20 gauge, 0.0346" design thickness) with ASTM A653/A653M G60 (Z180) hot dipped galvanized coating

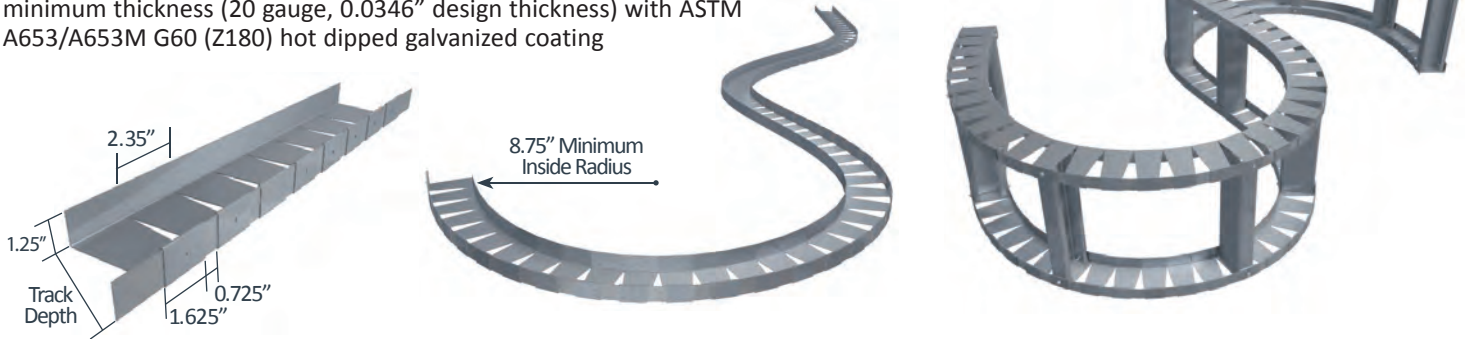

Product Designation	Thickness			
	Mils	Gauge	Design Thickness	
			in	mm
CircleTrak®	33	20	0.0346	0.878

Nomenclature

CircleTrak is available in 10' lengths and is designated by inside web depth x 100, then style (CT), followed by leg length and then material thickness in mils. Circletrak comes in standard 2.5, 3.5, 3.63, 5.5 and 6" web depths.

Example: 6" inside web depth

Designate: 600CT125-33

Example Details



NotchTrak® NT

Rigid Wall Backing & Bridging Alternative

The Steel Network, Inc. 
www.steelnetwork.com
1-888-474-4876

Material Composition

ASTM A1003/A1003M Structural Grade 50 (340) Type H, ST50H (ST340H): 50ksi (340MPa) minimum yield strength, 65ksi (450MPa) minimum tensile strength, with ASTM A653/A653M G60 (Z180) hot dipped galvanized coating, or equivalent.

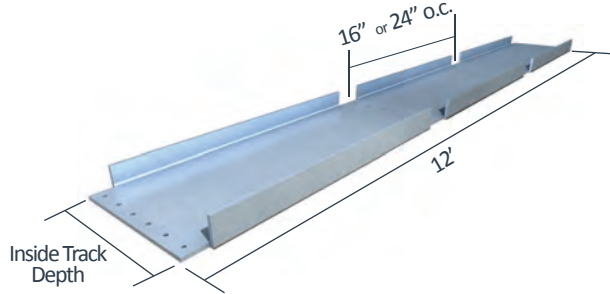

Patent Pending

Material Analysis

Designation	NotchTrak® NT Section Properties													Effective Properties 50 ksi				
	Gross Properties																	
	Area (Full) (in ²)	Area (Notch) (in ²)	I _x (in ⁴)	S _x (in ³)	R _x (in)	I _y (in ⁴)	R _y (in)	Jx10 ³ (in ⁴)	C _w (in ⁶)	R _o (in)	X _o (in)	m (in)	β	A _e (Full) (in ²)	I _x ¹ (in ⁴)	S _x (in ³)	M _{xa} (lbs-in)	V _a (lbs)
600NT125-43	0.383	0.262	1.861	0.604	2.205	0.044	0.337	0.260	0.307	2.289	-0.513	0.335	0.950	0.159	1.745	0.403	12,060	1,380
600NT125-54	0.480	0.329	2.345	0.757	2.209	0.054	0.335	0.513	0.384	2.292	-0.508	0.332	0.951	0.243	2.300	0.593	17,760	2,730
600NT125-68	0.605	0.414	2.971	0.951	2.216	0.067	0.332	1.025	0.483	2.296	-0.503	0.329	0.952	0.370	2.971	0.859	25,730	5,350
800NT125-43	0.473	0.352	3.773	0.925	2.824	0.046	0.311	0.321	0.589	2.874	-0.436	0.292	0.977	0.162	3.402	0.553	16,550	1,030
800NT125-54	0.594	0.442	4.747	1.158	2.828	0.057	0.309	0.634	0.735	2.877	-0.432	0.289	0.977	0.248	4.617	0.824	24,680	2,040
800NT125-68	0.748	0.557	6.001	1.455	2.833	0.070	0.307	1.267	0.920	2.882	-0.427	0.286	0.978	0.381	6.001	1.217	36,430	4,090

¹Effective moment of inertia, I_x, is calculated at a stress level equal to 0.6 F_y (service load level).

Example Details

NotchTrak® Used For Wall Bridging^{1,2}

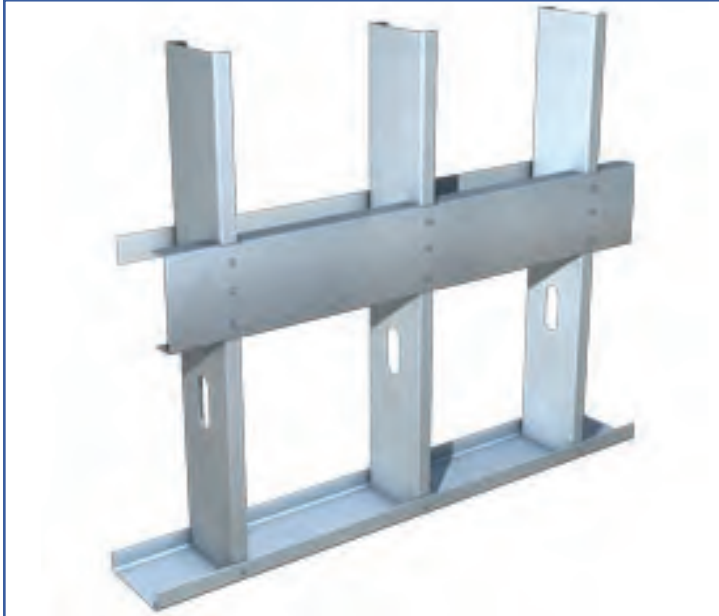

NotchTrak® Used For Wall Backing



¹ Use NotchTrak in conjunction with flat strap and blocking where applicable

² Design screw connection of track to stud for actual design load

****NotchTrak® allowable load tables continued on next page.**

Nomenclature

NotchTrak is manufactured in 12 ft. lengths. NotchTrak is designated by track depth in inches multiplied by 100, followed by type (NT), leg size, mil thickness and notch spacing.

Example:

600 NT 125 - 43 - 160c
(Inside Track Dimension) (NotchTrak) (Leg) (Thickness) (Notch Spacing)

* Special lengths available by request.

NotchTrak NT Allowable Loads

NotchTrak® NT, Recommended Allowable Load (lbs): Hanger													
Stud		16" o.c. stud spacing						24" o.c. stud spacing					
Thickness Mils (ga)	Yield Strength (ksi)	NT43		NT54		NT68		NT43		NT54		NT68	
		6" w/7 #12 Screws	8" w/10 #12 Screws	6" w/7 #12 Screws	8" w/10 #12 Screws	6" w/7 #12 Screws	8" w/10 #12 Screws	6" w/7 #12 Screws	8" w/10 #12 Screws	6" w/7 #12 Screws	8" w/10 #12 Screws	6" w/7 #12 Screws	8" w/10 #12 Screws
33 (20)	33	1,319	1,030	1,319	1,884	1,319	1,884	1,319	1,030	1,319	1,884	1,319	1,884
33 (20)	50	1,377	1,030	1,905	2,039	1,905	2,722	1,377	1,030	1,905	2,039	1,905	2,722
43 (18)	33	1,377	1,030	1,963	2,039	1,963	2,804	1,377	1,030	1,963	2,039	1,963	2,804
43 (18)	50	1,377	1,030	2,728	2,039	2,836	4,051	1,377	1,030	2,728	2,039	2,836	4,051
54 (16)	33	1,377	1,030	2,728	2,039	2,760	3,943	1,377	1,030	2,728	2,039	2,760	3,943
54 (16)	50	1,377	1,030	2,728	2,039	3,986	4,087	1,377	1,030	2,728	2,039	3,986	4,087
68 (14)	50	1,377	1,030	2,728	2,039	5,350	4,087	1,377	1,030	2,728	2,039	4,135	4,087
97 (12)	50	1,377	1,030	2,728	2,039	5,350	4,087	1,377	1,030	2,728	2,039	4,135	4,087
Max Allowable Member Load		1,377	1,030	2,728	2,039	5,350	4,087	1,377	1,030	2,728	2,039	4,135	4,087

NotchTrak® NT, Recommended Allowable Load (lbs): Axial							
Stud		16" & 24" o.c. stud spacing					
Thickness Mils (ga)	Yield Strength (ksi)	NT43		NT54		NT68	
		6" w/7 #12 Screws	8" w/10 #12 Screws	6" w/7 #12 Screws	8" w/10 #12 Screws	6" w/7 #12 Screws	8" w/10 #12 Screws
33 (20)	33	1,319	1,884	1,319	1,884	1,319	1,884
33 (20)	50	1,529	2,064	1,905	2,722	1,905	2,722
43 (18)	33	1,529	2,064	1,963	2,804	1,963	2,804
43 (18)	50	1,529	2,064	2,836	4,051	2,836	4,051
54 (16)	33	1,529	2,064	2,760	3,943	2,760	3,943
54 (16)	50	1,529	2,064	3,022	4,080	3,986	5,695
68 (14)	50	1,529	2,064	3,022	4,080	5,521	7,441
97 (12)	50	1,529	2,064	3,022	4,080	5,521	7,441
Maximum Allowable Member Load		1,529	2,064	3,022	4,080	5,521	7,441

NotchTrak® NT, Recommended Allowable Out of Plane Load (lbs): Lateral							
Stud		6" w/7 #12 Screws & 8" w/10 #12 Screws					
Thickness Mils (ga)	Yield Strength (ksi)	16" o.c. stud spacing			24" o.c. stud spacing		
		NT43	NT54	NT68	NT43	NT54	NT68
33 (20)	33	73	155	324	48	104	216
33 (20)	50	73	155	324	48	104	216
43 (18)	33	73	155	324	48	104	216
43 (18)	50	73	155	324	48	104	216
54 (16)	33	73	155	324	48	104	216
54 (16)	50	73	155	324	48	104	216
68 (14)	50	73	155	324	48	104	216
97 (12)	50	73	155	324	48	104	216
Max Allowable Member Load		73	155	324	48	104	216

Load Direction

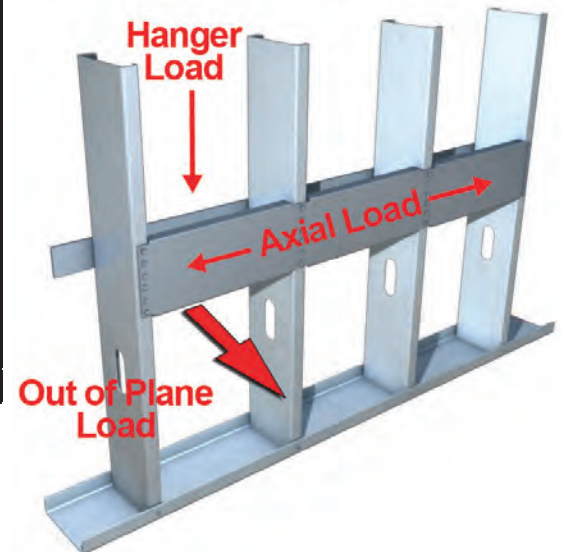

Notes:

- Table data based on 1.25" track leg, but other leg sizes are available to obtain higher capacities.
- NotchTrak NT resists weak axis buckling and torsional rotation of members.
- Meets OSHPD 2013 CBC Standard Backing Details for Cabinet and Grab Bar (Details ST5.00 and ST5.03)
- Meets OSHA & IBC load requirements.

BackIt®

Rigid Wall Backing

The Steel Network, Inc. 
 www.steelnetwork.com
 1-888-474-4876

Material Composition

ASTM A1003/A1003M Structural Grade 50 (340) Type H, ST50H (ST340H): 50ksi (340MPa) minimum yield strength, 65ksi (450MPa) minimum tensile strength, 43mil minimum thickness (18 gauge, 0.0451" design thickness) with ASTM A653/A653M G60 (Z180) hot dipped galvanized coating.

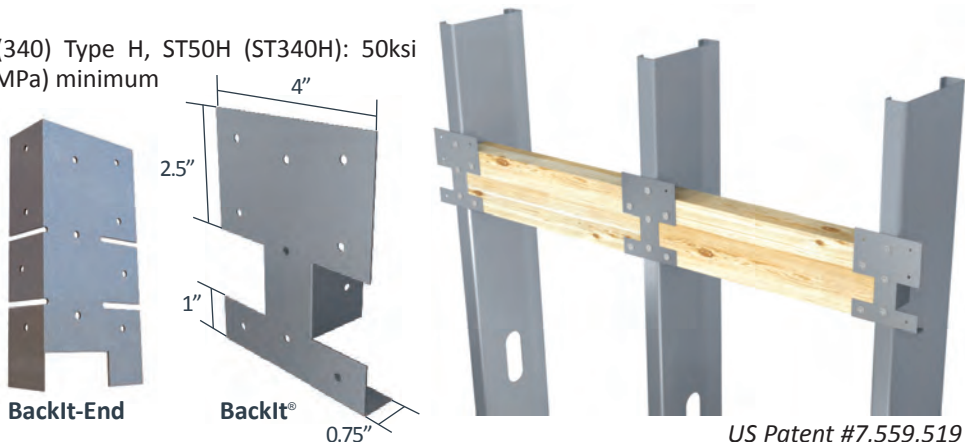

US Patent #7,559,519

BackIt Allowable Loads

BackIt®, Recommended Allowable Load (lbs) (in-lbs or in-lbs/rad): F2 & F3 & M1							
Stud		F2 Load Direction (lbs)		F3 Load Direction (lbs)		M1 Load Direction	
Thickness Mils (ga)	Yield Strength (ksi)	w/2 #12 screws	w/3 #12 screws	w/2 #12 screws	w/3 #12 screws	Moment	Stiffness
						w/3 #12 screws	up to 0.02 rad
18 (25)	33	--	155*	--	227	272	16,800
27 (22)	33	--	234	279	418	409	
30 (20dw)	33	--	258	322	483	451	
33 (20)	33	--	286	377	565	500	
33 (20)	50	275	391	544	817	722	
43 (18)	33	248	373	561	841	652	
43 (18)	50	359	391	810	1,215	942	
54 (16)	33	312	391	789	1,183	818	
54 (16), 68 (14) & 97 (12)	50	391	391	1,139	1,388	967	
Maximum Allowable Clip Load		391		1,388		967	

Notes:

- The recommended allowable loads and moments reported in this table are for the clip and attachment to the stud only. The attachment to the backing material must be designed by a design professional.

* Additional screws may be added to increase the allowable load. F2 value with (4) #12 screws is 207 lbs.

IBC (International Building Code) and OSHA (Occupational Safety and Health Administration) load requirements include the ability of wall backing to resist a minimum of 200 lbs of concentrated load, or 50 lbs per linear foot in any direction. BackIt satisfies the load requirements in vertical (F3) and horizontal (F2) directions. Extra testing has been done in the rotational (M1) direction. Product test reports are available upon request. Contact TSN Technical Support at (888) 474-4876 for more information.

Screw Patterns

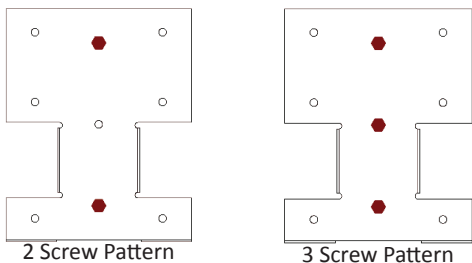

Nomenclature

BackIt is designed to be used with studs having flanges up to 1 5/8" wide*, and is designated BackIt®.

* Custom clips are available by request for use with studs having flanges greater than 1 5/8"

**Also Available by Request: End-of-Run BackIt® to finish walls with a flat angle

Load Direction

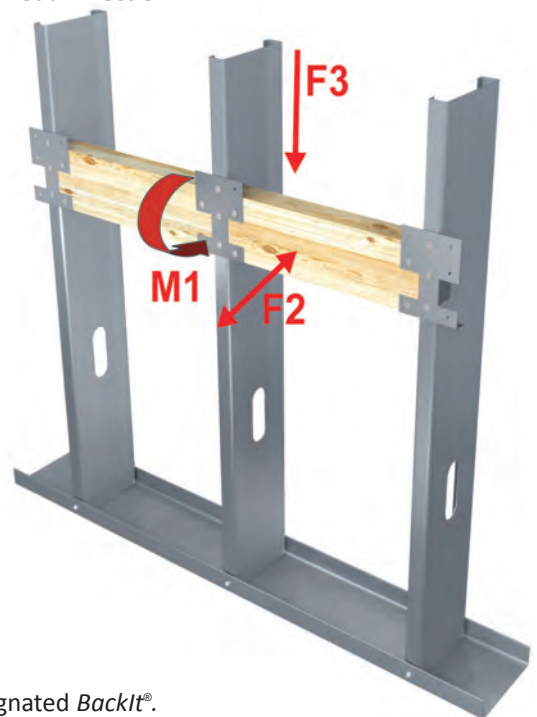

GripClip®

Column/Beam Connector

Material Composition

ASTM A1003 A1003/A1003M Structural Grade 33 (230) Type H, ST33H (ST230H): 33ksi (230MPa) minimum yield strength, 45ksi (310MPa) minimum tensile strength, 27mil minimum thickness (22 gauge, 0.0283" design thickness) with ASTM A653/A653M G60 (Z180) hot dipped galvanized coating.

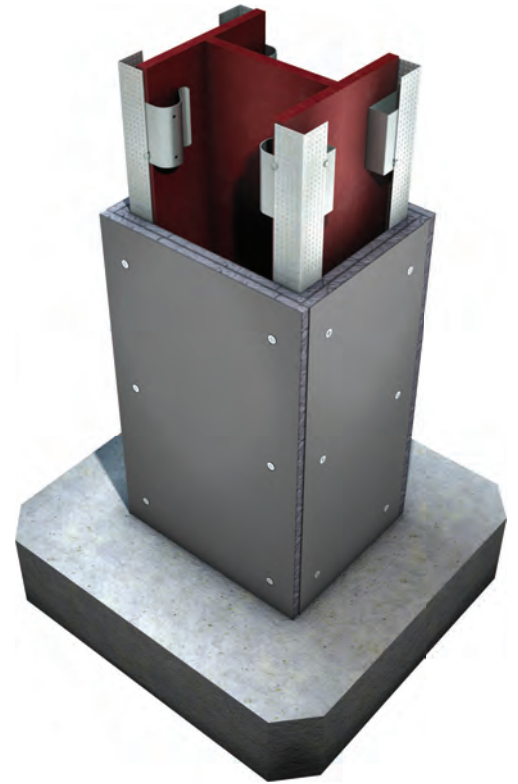
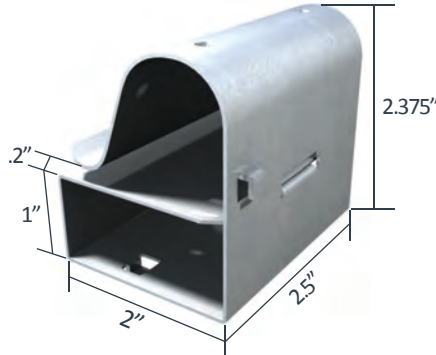

Patent # 8,132,383

Nomenclature

GripClip is made in one size and is designated *GripClip*®.

Example Details

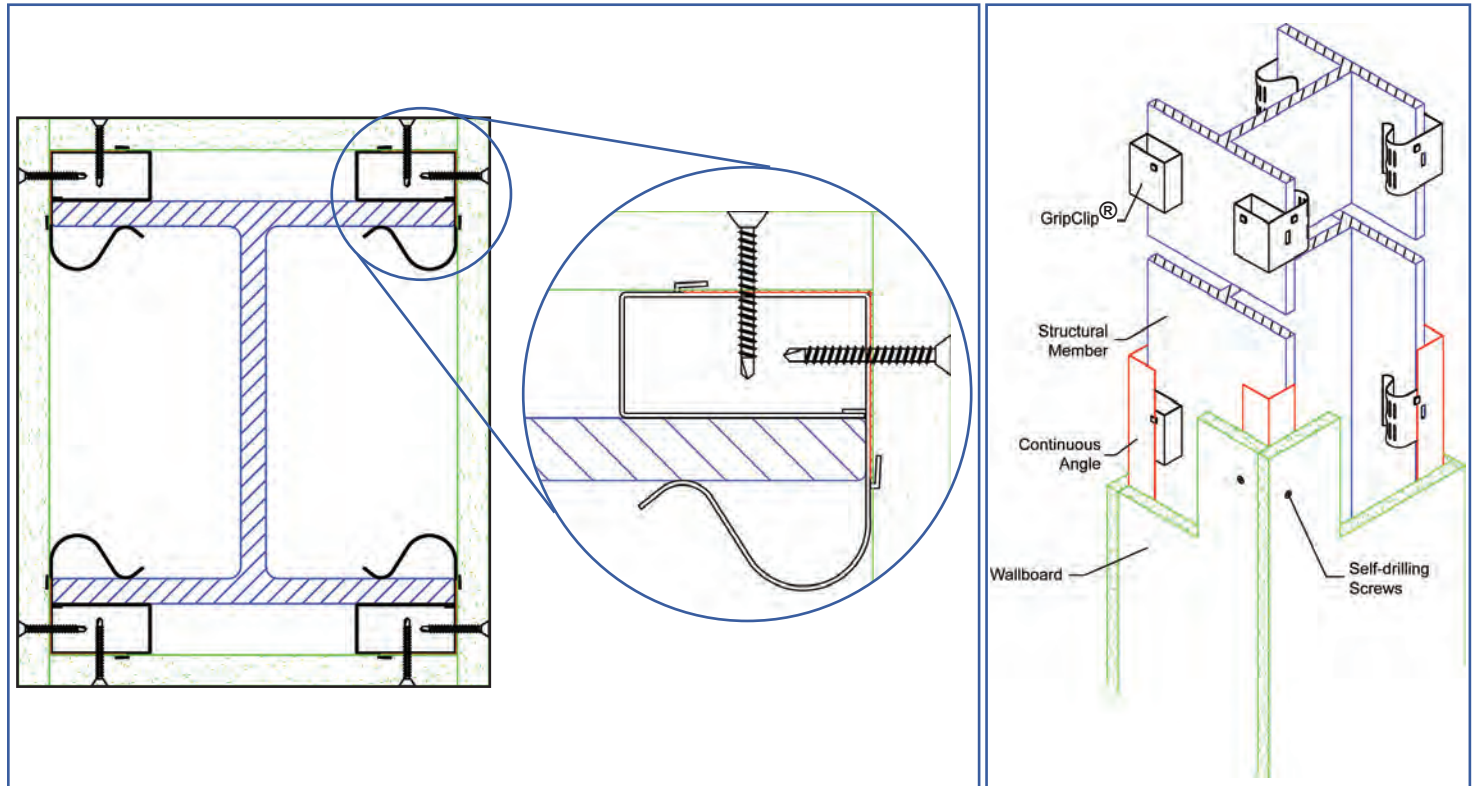

Common Clip Angle

Common Angle For All Applications

Material Composition

ASTM A1003/A1003M Structural Grade 50 (345) 50ksi (345MPa) minimum yield strength, 65ksi (450MPa) minimum tensile strength, with ASTM A653/A653M G90 (Z275) hot dipped galvanized coating. Available in 33mil minimum thickness (20 gauge, 0.0346" design thickness), 43mil minimum thickness (18 gauge, 0.0451" design thickness), 54mil minimum thickness (16 gauge, 0.0566" design thickness), 68mil minimum thickness (14 gauge, 0.0713" design thickness), 97mil minimum thickness (12 gauge, 0.1017" design thickness) or 118 mil minimum thickness (10 gauge, 0.1242" design thickness).

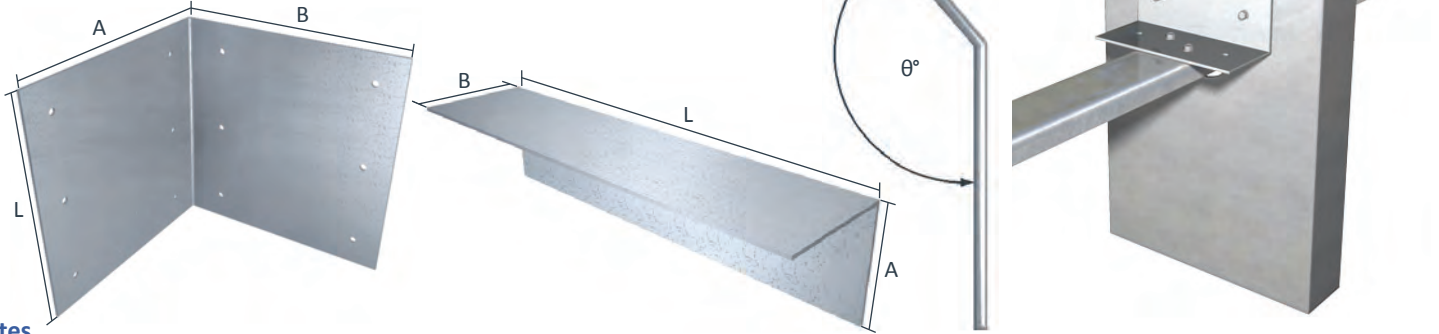

Notes

- The Steel Network is equipped to manufacture cold-formed steel connections of any size and shape. Some examples of common clip angle manufactured and stocked are shown below.
- Most common stocked angles come pre-punched for easier installation, although holes are not required.
- Contact TSN Sales for range of custom clip bend angles and for assistance designing custom products for special applications or requirements. Please allow reasonable time for production of all custom parts.
- Any thickness up to & including 10ga (118mil)
- Structural testing is available upon request.

Nomenclature

Clip angle can be manufactured to any specifications, however TSN stocks some more common sizes. Angle is classified with the letter "L" followed by (Leg A) x (Leg B) x length (inches), then mil thickness.

Example: Leg A = 3", Leg B = 3", Length = 5 1/2", 54 mil material
Designate: L3x3x5.5-54

* Special product drawings are required for all non-standard products.

Example Standard Common Clip Angle Details

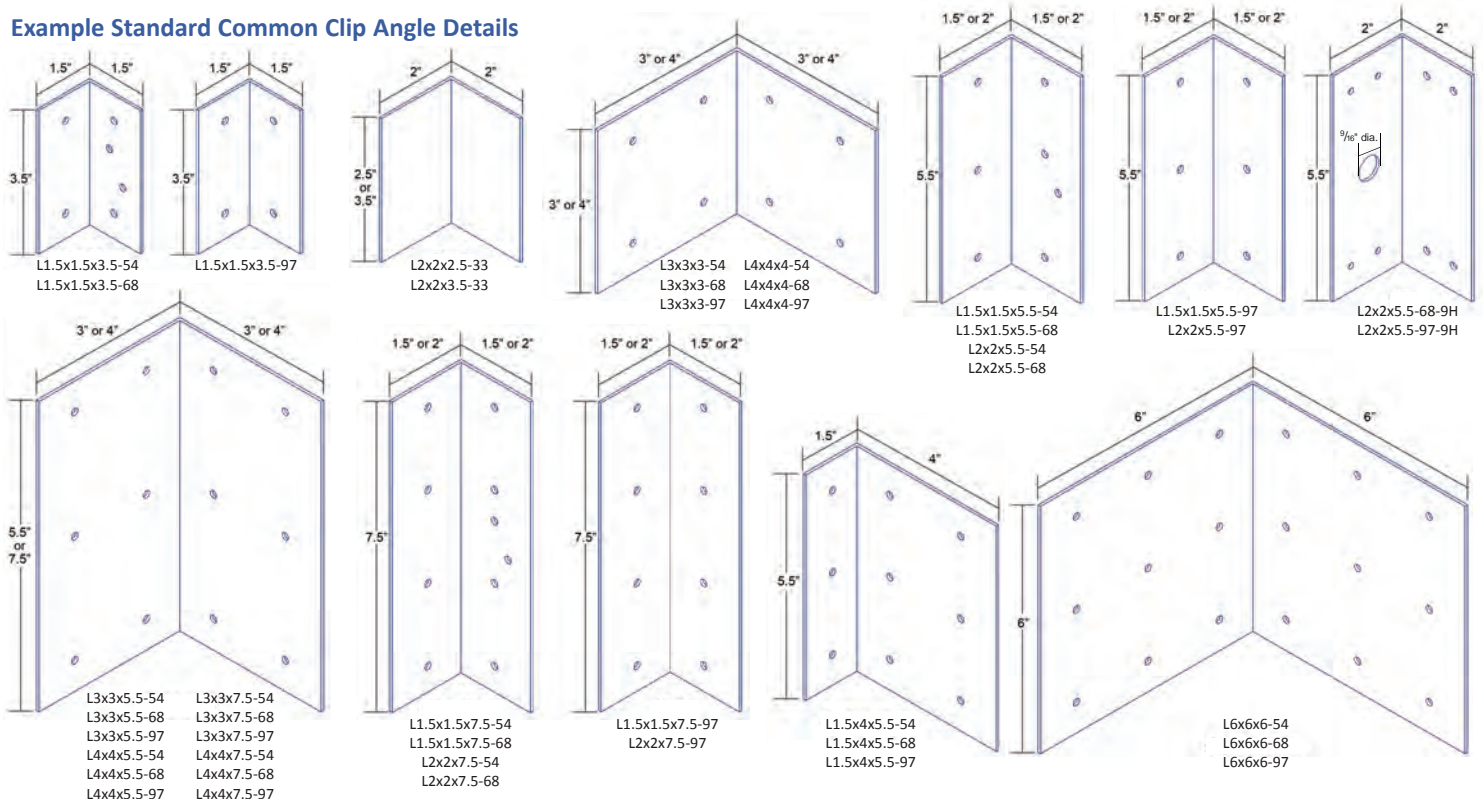

Custom Connectors

Specialized Products For All Applications

Material Composition

ASTM A1003/A1003M Structural Grade 50 (345) 50ksi (345MPa) minimum yield strength, 65ksi (450MPa) minimum tensile strength, with ASTM A653/A653M G90 (Z275) hot dipped galvanized coating. Available in 33mil minimum thickness (20 gauge, 0.0346" design thickness), 43mil minimum thickness (18 gauge, 0.0451" design thickness), 54mil minimum thickness (16 gauge, 0.0566" design thickness), 68mil minimum thickness (14 gauge, 0.0713" design thickness), 97mil minimum thickness (12 gauge, 0.1017" design thickness) or 118 mil minimum thickness (10 gauge, 0.1242" design thickness).

Notes

- The Steel Network is equipped to manufacture cold-formed steel connections of any size and shape. Some examples of custom products manufactured are shown and described below.
- Please allow reasonable time for production of all custom parts.
- Structural testing is available upon request.
- Contact TSN for assistance designing custom products for special applications or requirements.

Nomenclature

Contact TSN with product requirements

* Special product drawing is required for all non-standard products.

Example Details



Custom VertiClip® SLB

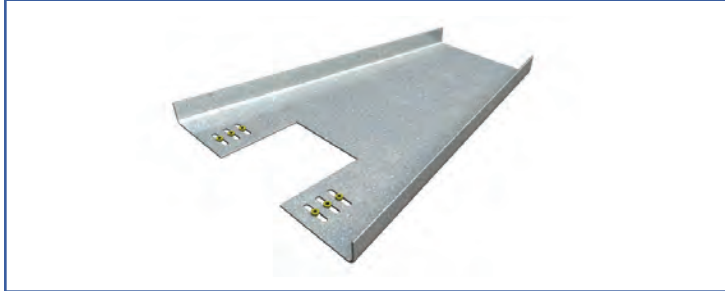

Unique condition brought to TSN by Specialty Engineer. TSN helped design a solution and test & fabricate clips.

Custom VertiClip® Splice (Notched)



Unique condition brought to TSN by Specialty Engineer. TSN helped design a solution and test & fabricate clips.

Custom VertiClip® Splice (Angled)



Unique condition brought to TSN by Specialty Engineer. TSN helped design a solution and test & fabricate clips.

Custom VertiClip® Splice



Connector for parallel wall studs. One stud rigidly attached to wall stud. The other stud accommodates vertical deflection of the primary structural frame.

Custom VertiClip® SLS (extra long)

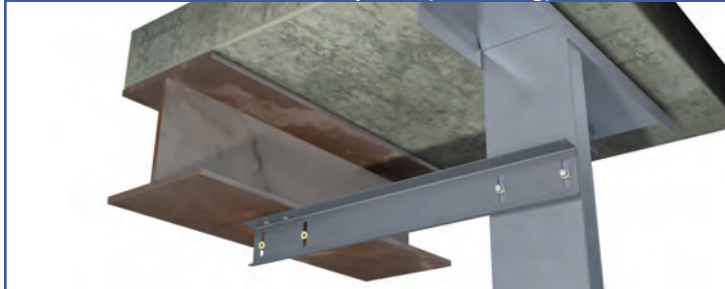

Retrofit situation where a stud does not run full height, creating a situation where a modified VertiClip SLS was lengthened to bridge a large gap from the structure of 26".

Custom VertiTrak® VTD (VertiClip® SLD with Elongated Slots)



VertiTrak VTD modified to accommodate 4" slots in VertiClip SLD provides an effective, efficient solution for large demising walls typically seen in retail stores and theaters.

Blast & Seismic Design

Load Tables

Background

Various specifications and design standards allow the use of nominal strength of material when calculating resistance values of components for special blast or seismic design. Beyond the use of nominal strength, some design codes allow the use of an increased nominal strength or an increased expected strength. The Steel Network has developed the following tables to present the LRFD design strength, nominal strength, and ultimate strength for each connector manufactured which can be used in special seismic and blast design and are compatible with the Static and Dynamic Strength Increase factors.

For additional information the full tech note, Strength Tables for Special Seismic and Blast Design of Cold Formed Steel Connections is available at www.steelnetwork.com/Site/TechnicalNotes

VertiClip® Series (lbs)				
Connector	Load Direction	LRFD Design Strength	Nominal Strength	Ultimate Strength
SL362	F1	397	441	721
	F2	1,696	1,885	2,680
SL400	F1	318	353	600
	F2	1,817	2,019	3,074
SL600	F1	588	653	1,068
	F2	2,691	2,990	4,251
SL800	F1	579	643	1,052
	F2	2,994	3,327	4,730
SL1000	F1	664	738	1,206
	F2	2,521	2,801	4,266
SL1200	F1	611	679	1,110
	F2	2,863	3,182	4,845
SLD150	F2	82	91	139
SLD250	F2	254	282	430
SLD362/400	F2	575	639	973
SLD600	F2	648	720	1,302
SLD800	F2	1,091	1,212	1,844
SLB362	F1	364	405	661
	F2	2,563	2,848	4,381
SLB600	F1	364	405	661
	F2	2,563	2,848	4,381
SLB800	F1	357	397	604
	F2	2,563	2,848	4,381
SLB1000	F2	2,266	2,517	4,112
SLB1200	F2	2,266	2,517	4,112
SLBxxx-10, -12	F2	2,266	2,517	4,112
SLB600-HD, (2) ¼" Screws	F1	374	416	679
	F2	1,901	2,112	3,216
SLB600-HD, (1) ½" Anchor	F1	388	431	704
	F2	1,606	1,785	2,718
SLS362/400-9, -12	F2	1,991	2,096	3,821
SLS600-12	F2	3,315	3,489	5,237
SLS600-15, -18, -20	F2	3,398	3,577	5,750
SLS600-24	F2	3,036	3,196	5,137
SLS800-12, -15, -18, -20	F2	2,909	3,062	4,922
SLT9.5	F1	546	575	991
	F2	822	865	1,492
SLT(L)	F1	784	825	1,422
	F2	1,116	1,175	2,026
Splice600	F2	2,282	2,402	3,861
	F3	3,888	4,092	6,578
Splice800	F2	2,282	2,402	3,861
	F3	3,639	4,044	6,158

MasterClip® Series (lbs)				
Connector (Application)	Load Direction	LRFD Design Strength	Nominal Strength	Ultimate Strength
VLB600 (Vertical Deflection)	F1	364	405	661
	F2	2,509	2,788	4,245
VLB600 (Rigid Connection)	F1	1,481	1,646	2,506
	F2	3,297	3,664	5,579
	F3	2,869	3,188	4,855

DriftClip® & DriftTrak® Series (lbs)					
Connector	Load Direction	Fastener Pattern	LRFD Design Strength	Nominal Strength	Ultimate Strength
DSL362	F2	1	1,467	1,630	2,317
		2	916	1,018	1,663
DSL600-12	F2	1	2,980	3,311	4,707
		2	2,788	3,098	4,405
DSL600-15	F2	1	3,045	3,383	4,811
DSL600-15 ¹	F2	2	3,045	3,383	5,008
DSL800	F2	1	186	207	317
		2	85	94	141
DSL1200	F2	1	286	317	481
		2	399	443	669
DSL1800	F2	1	318	354	578
		2	293	326	558
DSL362	F2	1	796	884	1,320
		2	397	441	720
DSL600	F2	1	1,242	1,380	2,254
		2	1,840	2,044	3,051
DSL800	F2	1	1,666	1,851	3,023
		2	1,666	1,851	4,122
DTSL	F2	8" Fastener Spacing - Pattern 1	1001	1,112	1,807
		8" Fastener Spacing - Pattern 2	770	856	1,303
		16" Fastener Spacing - Pattern 1	1,338	1,487	2,264
		16" Fastener Spacing - Pattern 2	774	860	1,309
DTSLB362/400, 600, 800	F2	8" Fastener Spacing - Patterns 1 & 2	1,292	1,435	2,186
		16" Fastener Spacing - Patterns 1 & 2	1,206	1,340	2,040
DTSLB-HD 362/400, 600, 800	F2	8" Fastener Spacing - Patterns 1 & 2	2,591	2,879	4,384
		16" Fastener Spacing - Patterns 1 & 2	1,640	1,822	2,775
DTLB600	F2	8" Fastener Spacing	1,292	1,435	2,186
			2,434	2,704	4,118
DTLB800	F2	8" Fastener Spacing	1,292	1,435	2,186
			2,434	2,704	4,118

Notes:

- ¹LRFD strength limited by fastener pattern 1.
- Strength values provided are those of the clip only (one clip). Attachment to stud framing and to structure must be evaluated independently.
- Nominal Strength is calculated as LRFD Strength divided by an average resistance factor of 0.9.
- Ultimate Strength is the average maximum load obtained from tests.
- When dynamic analysis is used for blast design, the Nominal Strength may be allowed to be increased by a Static Increase Factor (SIF) and a Dynamic Increase Factor (DIF).

Visit www.steelnetwork.com/Site/TechnicalNotes to view the full technical note on Blast and Seismic Design.

StiffClip® Series (lbs or in-lbs)					StiffClip® Series (lbs or in-lbs)				
Connector	Load Direction	LRFD Design Strength	Nominal Strength	Ultimate Strength	Connector	Load Direction	LRFD Design Strength	Nominal Strength	Ultimate Strength
AL362	F1	1,177	1,308	2,137	CL362/400-118	F1	2,267	2,519	4,122
	F2	2,493	2,770	4,219		F2	3,071	3,412	4,851
	F3	4,522	5,025	7,652		F3	1,842	2,047	3,349
AL600	F1	1,388	1,542	2,348		M1 (in-lbs)	2,888	3,209	5,251
	F2	3,493	3,882	5,911	CL362/400-118	F1	3,880	4,311	6,129
	F3	4,830	5,366	8,172		F2	7,090	7,878	11,201
AL800	F1	2,827	3,141	4,784		F3	3,611	4,012	6,565
	F2	4,022	4,469	6,806		M1 (in-lbs)	6,299	6,999	11,453
	F3	9,798	10,887	16,579	CL362/400-118H	F1	4,160	4,622	6,572
LB362	F1	1,481	1,646	2,506		F2	7,973	8,858	12,595
	F2	3,297	3,664	5,579		F3	9,150	10,167	14,455
	F3	4,256	4,729	7,202		M1 (in-lbs)	10,750	11,944	19,545
LB600	F1	1,481	1,646	2,506	CL600-68	F1	2,275	2,528	3,594
	F2	3,297	3,664	5,579		F2	4,020	4,467	6,351
	F3	3,080	3,423	5,212		F3	1,932	2,147	3,513
LB800	F1	1,993	2,214	3,617		M1 (in-lbs)	4,978	5,531	9,050
	F2	3,297	3,664	5,579	CL600-118	F1	4,131	4,590	7,147
	F3	6,188	6,875	10,470		F2	6,578	7,308	10,391
LB800-4" Offset	F1	1,993	2,214	3,617		F3	3,561	3,956	6,474
	F2	3,297	3,664	5,579		M1 (in-lbs)	9,126	10,140	16,592
	F3	2,496	2,773	4,223	CL600-118H	F1	6,659	7,399	10,520
LB1000	F1	1,465	1,627	2,658		F2	10,337	11,485	16,330
	F2	2,270	2,522	4,120		F3	9,620	10,689	15,197
	F3	2,872	3,191	4,859		M1 (in-lbs)	9,958	11,065	18,106
LB1000 - 4" Offset	F2	2,270	2,522	4,120	CL800-68	F1	2,298	2,553	3,630
	F3	2,506	2,784	4,240		F2	4,263	4,736	6,734
LB1200	F1	1,465	1,627	2,658		F3	1,724	1,916	3,135
	F2	2,270	2,522	4,120		M1 (in-lbs)	4,578	5,086	8,323
	F3	3,041	3,379	5,146	CL800-118	F1	5,375	5,972	8,491
LB600-HD, (2) ¼" Screws	F1	1,764	1,959	2,984		F2	10,265	11,406	16,217
	F2	1,810	2,011	3,062		F3	4,270	4,744	8,291
	F3	3,149	3,499	5,328		M1 (in-lbs)	13,170	14,634	23,946
HE(L)-43	F2	1,003	1,114	1,696	CL800-118H	F1	7,713	8,570	12,185
	F3	4,901	5,446	8,293		F2	13,251	14,723	20,933
HE(H)-68	F2	1,739	1,932	2,943		F3	11,925	13,250	18,839
	F3	8,880	9,867	15,026		M1 (in-lbs)	17,834	19,815	32,425
HE(S)-68	F2	1,739	1,932	2,943	TD	F3	15,722	17,469	19,127
	F3	4,753	5,281	8,043					
HS362	F2*	4,420	8,840	11,492					
	F3	1,773	1,970	3,000					
HS600	F2*	6,630	13,260	17,238					
	F3	2,943	3,270	4,980					
HS800	F2*	6,630	13,260	17,238					
	F3	3,885	4,317	6,574					

Notes:

- Strength values provided are those of the clip only (one clip). Attachment to stud framing and to structure must be evaluated independently.
- Nominal Strength is calculated as LRFD Strength divided by an average resistance factor of 0.9.
- Ultimate Strength is the average maximum load obtained from tests.
- When dynamic analysis is used for blast design, the Nominal Strength may be allowed to be increased by a Static Increase Factor (SIF) and a Dynamic Increase Factor (DIF).
- Clip connectors or load directions marked with an (*) have their LRFD, nominal, and ultimate strength values all calculated using AISI S100-12 provisions.

Building Codes & Fire Ratings

Building Code Reference

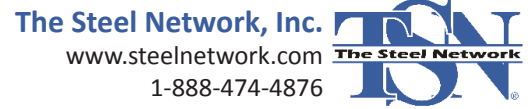

ICC-ES

The Steel Network assisted the ICC-ES in the development of AC261, "Acceptance Criteria for Connectors Used with Cold-Formed Steel Structural Members," which establishes test protocols and requirements for connections used in cold-formed steel assemblies. TSN provides structural test reports for each connector product which are in compliance with the listed criteria.

2006 IBC (Section 713.2), 2009 IBC (Section 714.2) and 2012 IBC (Section 715.2):

Installation: Fire-resistant joint systems shall be securely installed in or on the joint for its entire length so as not to dislodge, loosen or otherwise impair its ability to accommodate expected building movements and to resist the passage of fire and hot gases.

2006 IBC (Section 713.3), 2009 IBC (Section 714.3) and 2012 IBC (Section 715.3):

Fire test criteria: Fire-resistant joint systems shall be tested in accordance with the requirements of either ASTM E 1966 or UL 2079.



ICC-ES Evaluation Reports for select VertiClip®, DriftClip® & DriftTrak® products are available. Refer to ICC-ES ESR-2049 at www.icc-es.org or at www.steelnetwork.com



A New York MEA Acceptance for VertiClip SLD & VertiTrack® VTD is available. Refer to MEA-326-06-M.

Fire Rating Criteria

Full-height interior partitions are often required to be fire-rated. Fire-resistive joint systems require movement capabilities at head of wall. UL 2079 is a test standard for fire-resistive joint systems and includes requirements for the system's ability to allow building movement. Since the runner track or deflection channel in UL HW-D (Head of Wall-Dynamic) fire-resistive joint system assemblies provide closure to the assembly and must be fire tested for each assembly, the clip components of the assembly must only satisfy the criteria for cyclic movement. The Steel Network's VertiClip® SLD and DriftClip® DSLD series clips both satisfy the criteria for cyclic movement and are classified for use in all UL 2079 rated assemblies with a 1 or 2 hour ratings and up to 1-1/2" of deflection for SLD and 2" of deflection for DSLD. The Steel Network's VertiTrack® VTD, VTX and VT are also classified for use in certain UL HW-D fire-resistive joint system assemblies as listed below.

UL®-Classified Assemblies

VertiClip® SLD150, SLD250, SLD362, SLD400, SLD600 and SLD800 installed with standard ceiling runners or generic deflection channels are classified for use in all UL 2079 rated Head of Wall-Dynamic joint systems rated for 1 or 2 hours with maximum movement capabilities of 3/4" compression and 3/4" extension.

DriftClip® DSLD362/400, DSLD600 and DSLD800 installed with standard ceiling runners or generic deflection channels are classified for use in all UL 2079 rated Head of Wall-Dynamic joint systems rated for 1 or 2 hours with maximum movement capabilities of 1" compression and 1" extension.

VertiTrack VTD or VTX, Series 250, 362, 400, 600 and 800 consist of VertiClip SLD and SL clips pre-attached to a standard top track. VertiTrack VTD and VTX both allow maximum movement capabilities of 3/4" compression and 3/4" extension and are classified for use in the following UL HW-D joint system details:



- HW-D-0003, HW-D-0024, HW-D-0025, HW-D-0036, HW-D-0042, HW-D-0043, HW-D-0044, HW-D-0045, HW-D-0046, HW-D-0047, HW-D-0048, HW-D-0049, HW-D-0054, HW-D-0062, HW-D-0063, HW-D-0066, HW-D-0067, HW-D-0068, HW-D-0069, HW-D-0071, HW-D-0072, HW-D-0073, HW-D-0076, HW-D-0077, HW-D-0082, HW-D-0083, HW-D-0084, HW-D-0085, HW-D-0087, HW-D-0089, HW-D-0091, HW-D-0102, HW-D-0106, HW-D-0152, HW-D-0154, HW-D-0160, HW-D-0162, HW-D-0167, HW-D-0184, HW-D-0185, HW-D-0186, HW-D-0190, HW-D-0193, HW-D-0209, HW-D-0218, HW-D-0246, HW-D-0256, HW-D-0259, HW-D-0263, HW-D-0271, HW-D-0272, HW-D-0275, HW-D-0277, HW-D-0278, HW-D-0280, HW-D-0293, HW-D-0299, HW-D-0310, HW-D-0313, HW-D-0321, HW-D-0322, HW-D-0324, HW-D-0341, HW-D-0342*, HW-D-0353, HW-D-0356, HW-D-0357, HW-D-0358, HW-D-0363, HW-D-0365, HW-D-0368, HW-D-0370, HW-D-0371, HW-D-0401*, HW-D-0404, HW-D-0420, HW-D-0421, HW-D-0453, HW-D-0455, HW-D-0460, HW-D-0461, HW-D-0462, HW-D-0463, HW-D-0466, HW-D-0468, HW-D-0470, HW-D-0475, HW-D-0477, HW-D-0483, HW-D-0491, HW-D-0526, HW-D-0527, HW-D-0532, HW-D-0545, HW-D-0639, HW-D-0642*, HW-D-0644*, HW-D-0645*, HW-D-0646*, HW-D-0687, HW-D-0689, HW-D-0695, HW-D-0696

VertiTrack VT series 250VT, 362VT, 400VT, 600VT and 800VT with the suffix 250-33 is slotted deflection track that is an improvement on generic deflection channel. VertiTrack VT allows maximum movement capabilities of 3/4" compression and 3/4" extension and is classified for use in the following UL HW-D joint system details:

- HW-D-0043, HW-D-0044, HW-D-0054, HW-D-0088, HW-D-0099, HW-D-0154, HW-D-0184, HW-D-0194*, HW-D-0218, HW-D-0252, HW-D-0259, HW-D-0264, HW-D-0324, HW-D-0363, HW-D-0377, HW-D-0388, HW-D-0456, HW-D-0538, HW-D-0539, HW-D-0540, HW-D-0548*, HW-D-0606

The list is updated as UL classifies new assemblies. Please visit www.steelnetwork.com/FireRated and click on the UL link for a complete list of VertiTrack HW-D classified fire rated construction systems.

* Shaft wall assemblies

Terms, Conditions & Limited Warranty

For All Products Manufactured by The Steel Network, Inc.

Product Use

Products in this catalog are designed and manufactured for the specific purposes shown, and should not be used in other applications unless approved by a qualified design professional. All modifications to products or changes in installation procedures should be made by a qualified design professional. The performance of such modified products or altered installation procedures is the sole responsibility of the design professional or installation contractor. The installation contractor and/or qualified design professional are responsible for installing all products in accordance with relevant specifications and building codes.

Customers modifying products or installation procedures, or designing Custom products for fabrication by The Steel Network, Inc. ("TSN") shall, regardless of specific instructions to the user, indemnify, defend, and hold TSN harmless for any and all claimed loss or damage occasioned in whole or in part by Custom or modified products or installation procedures.

Loads published on TSN's website and current product catalogs are for the described specific applications of properly installed products. Modifications to TSN products, improper loading or installation procedures, or deviations from recommended applications will affect TSN products' load-carrying capacities. TSN products are fabricated from hot-dipped galvanized steel for corrosion protection but will corrode and lose load-carrying capacity if exposed to salt air, corrosive fire-retardant chemicals, fertilizers, or other substances that may adversely affect steel or its galvanized coating. The current editions of TSN's catalogs and load tables published on this website may reflect changes in the allowable loads and configurations of some of TSN's products. This information supersedes information in earlier catalogs or technical reports. All earlier catalogs or technical reports should be discarded and reference made exclusively to the versions available at <http://www.steelnetwork.com/Site/Catalogs>. TSN may correct any clerical or typographical errors. All sales are subject to TSN's standard terms and conditions of sale.

Limited Warranty

TSN warrants its products to be free from defects in material or workmanship at the time of shipment. TSN standard catalog products are warranted for adequacy of design when used in accordance with design limits in this catalog and properly specified and installed. TSN products shall not be substituted with non-TSN products if it is part of a system. Substitution of a TSN product will immediately void any warranty claim made by Purchaser. This warranty excludes uses not in compliance with specific applications and installation procedures set forth in this catalog. Warranty claims must be made by Purchaser in writing within ninety (90) days of receipt of the products.

All warranty obligations of TSN shall be limited, at the sole discretion of TSN, to repair or replace the defective product(s). These remedies shall constitute TSN's sole obligation and sole remedy of purchaser under this warranty. In no event will TSN be responsible for incidental, consequential, indirect, exemplary, special, consequential, or punitive damages, or other losses or damages however caused, including, but not limited to, installation costs, lost revenue or lost profits. TSN's liability for damages shall in no event exceed the applicable portion of the purchase price for defective product(s).

Product defects that arise from acts of God, accidents, misuse, misapplication, improper installation, storage damage, negligence, or modification to product(s) or its components are specifically excluded from this warranty. Product defects that arise from Purchaser providing incorrect information to TSN, including but not limited to incorrect specifications such as incorrect dimensions, designs and/or loads, are also specifically excluded from this warranty. TSN does not authorize any person or party to assume or create for it any other obligation or liability in connection with Products except as set forth herein.

This Warranty is expressly in lieu of all other warranties, expressed or implied, including any warranties of merchantability or fitness for a particular purpose, all such other warranties being hereby expressly excluded.

Patented Technology

BackIt®, BridgeBar®, BridgeClip®, BuckleBridge®, CircleTrak®, DriftClip®, DriftCorner®, DriftTrak®, GripClip®, 600JAM®, 800JAM®, JamStud®, MidWall™, MasterClip®, NotchTrak®, PrimeWall®, 600SG®, 800SG®, SigmaStud®, SigmaTrak®, Step-Bushing Technology™, StiffClip®, StiffWall®, ThermaFast®, TightStrap®, VertiClip®, and VertiTrack® are trademarked products, and are patented or patent-pending technologies of TSN. Numerous TSN design configurations are patented and/or patent pending and are protected under US and International patent laws. Patent numbers include: #4,970,410; #4,970,411; #4,970,412; #4,970,413; #5,079,710; #5,467,566; #5,904,023; #5,906,080; #6,612,087; #6,701,689; #6,892,504; #7,104,024; #7,503,150; #7,559,519; #7,596,921; #7,634,889; #7,788,878; #7,832,162; #7,836,657; #8,132,383; #8,181,419; #8,205,402; #8,387,321 and #8,683,770.

Contact Information

North Carolina

(Headquarters)
 2012-A T W Alexander Drive
 P.O. Box 13887
 Durham, NC 27709
 Phone: (919) 845-1025
 Fax: (888) 474-4877

Texas

600 Lemens Avenue
 Suite 120
 Hutto, TX 78634
 Phone: (512) 642-9603
 Fax: (512) 857-1663

Nevada

4460 Arville Street
 Suite #5
 Las Vegas, NV 89103
 Phone: (702) 643-4330
 Fax: (702) 643-4331

Web Site: www.steelnetwork.com
E-mail: support@steelnetwork.com
Toll Free Nationwide Phone
(888) 474-4876



