

StiffClip® CL

Floor Tie

Material Composition

68mil Clip: ASTM A1003/A1003M Structural Grade 50 (340) Type H, ST50H (ST340H): 50ksi (340MPa) minimum yield strength, 65ksi (450MPa) minimum tensile strength, 68mil minimum thickness (14 gauge, 0.0713" design thickness) with ASTM A653/A653M G90 (Z275) hot dipped galvanized coating.

118mil Clip: ASTM A1003/A1003M Structural Grade 50 (340) Type H, ST50H (ST340H): 50ksi (340MPa) minimum yield strength, 65ksi (450MPa) minimum tensile strength, 118mil minimum thickness (10 gauge, 0.1242" design thickness) with ASTM A653/A653M G90 (Z275) hot dipped galvanized coating.

"H" Plate: ½" steel, ASTM A36, 36ksi min yield, 58-80ksi min tensile, with ASTM B633 Type II Yellow Zinc Coating, or Paint, or Equivalent.

The attachment of StiffClip to the primary structure may be made with PAFs, screw/bolt anchors or weld and is dependent upon the base material (steel or concrete) and the design configuration.

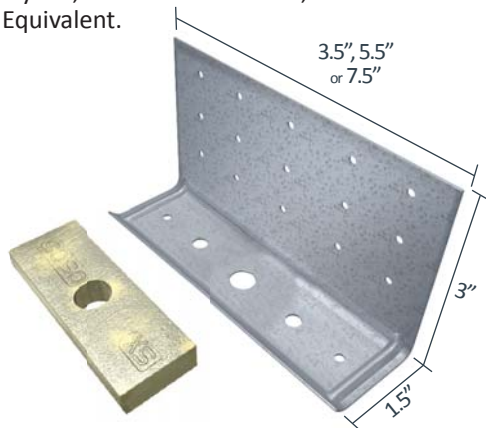
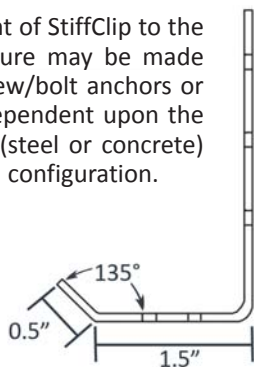

CL (H) Plate



US Patent #7,533,508

StiffClip CL Allowable Loads

StiffClip® CL362/400, Recommended Allowable Load (lbs and inches): F1, F2, F3, M1 & Stiffness																
Stud		CL362/400-68					CL362/400-118					CL362/400-118 (H)				
Thickness Mils (ga)	Yield Strength (ksi)	4 #12 Screws, Pattern 1					4 #12 Screws, Pattern 1					9 #12 Screws, Pattern 2				
		F1 (lbs)	F2 (lbs)	F3 (lbs)	M1 (in-lbs)	Stiffness (in-lbs/rad)	F1 (lbs)	F2 (lbs)	F3 (lbs)	M1 (in-lbs)	Stiffness (in-lbs/rad)	F1 (lbs)	F2 (lbs)	F3 (lbs)	M1 (in-lbs)	Stiffness (in-lbs/rad)
33 (20)	33	191	535	754	1,108	108,054	191	535	754	1,108	297,793	286	980	1,696	1,653	457,277
33 (20)	50	275	773	1,089	1,601		275	773	1,089	1,601		413	1,415	2,450	2,388	
43 (18)	33	248	796	1,122	1,649		248	796	1,122	1,649		373	1,458	2,524	2,460	
43 (18)	50	359	1,150	1,151	1,804		359	1,150	1,620	2,383		538	2,107	3,646	3,554	
54 (16)	33	312	1,120	1,151	1,804		312	1,120	1,577	2,319		468	2,050	3,549	3,459	
54 (16)	50	450	1,617	1,151	1,804		450	1,617	2,225	3,350		676	2,961	5,126	4,996	
68 (14)	50	567	1,917	1,151	1,804		567	2,287	2,225	3,936		851	4,187	5,713	6,716	
97 (12)	50	809	1,917	1,151	1,804		809	2,411	2,225	3,936		1,214	4,415	5,713	6,716	
118 (10)	50	856	1,917	1,151	1,804	856	2,411	2,225	3,936	1,284	4,415	5,713	6,716			
Max Allowable Clip Load		1,416	1,917	1,151	1,804		2,423	4,107	2,225	3,936		2,598	4,978	5,713	6,716	

StiffClip® CL600, Recommended Allowable Load (lbs and inches): F1, F2, F3, M1 & Stiffness																
Stud		CL600-68					CL600-118					CL600-118 (H)				
Thickness Mils (ga)	Yield Strength (ksi)	6 #12 Screws, Pattern 3					6 #12 Screws, Pattern 3					10 #12 Screws, Pattern 4				
		F1 (lbs)	F2 (lbs)	F3 (lbs)	M1 (in-lbs)	Stiffness (in-lbs/rad)	F1 (lbs)	F2 (lbs)	F3 (lbs)	M1 (in-lbs)	Stiffness (in-lbs/rad)	F1 (lbs)	F2 (lbs)	F3 (lbs)	M1 (in-lbs)	Stiffness (in-lbs/rad)
33 (20)	33	286	874	1,067	1,713	160,215	286	874	1,130	1,713	354,427	381	1,481	1,884	3,140	525,127
33 (20)	50	413	1,263	1,067	2,435		413	1,263	1,633	2,475		550	2,139	2,722	4,537	
43 (18)	33	373	1,301	1,067	2,435		373	1,301	1,682	2,549		497	2,204	2,804	4,673	
43 (18)	50	538	1,880	1,067	2,435		538	1,880	2,225	3,683		718	3,184	4,051	6,755	
54 (16)	33	468	1,830	1,067	2,435		468	1,830	2,225	3,585		624	3,099	3,943	6,571	
54 (16)	50	676	2,510	1,067	2,435		676	2,642	2,225	5,177		901	4,476	5,695	7,306	
68 (14)	50	851	2,510	1,067	2,435		851	3,736	2,225	5,702		1,134	6,329	6,007	7,306	
97 (12)	50	1,214	2,510	1,067	2,435		1,214	3,939	2,225	5,702		1,618	6,455	6,007	7,306	
118 (10)	50	1,284	2,510	1,067	2,435	1,284	3,939	2,225	5,702	1,712	6,455	6,007	7,306			
Max Allowable Clip Load		1,421	2,510	1,067	2,435		2,580	4,107	2,225	5,702		4,158	6,455	6,007	7,306	

****StiffClip CL Allowable Load tables and important notes continued on next page.**

StiffClip® CL800, Recommended Allowable Load (lbs and inches): F1, F2, F3, M1 & Stiffness																
Stud		CL800-68					CL800-118					CL800-118 (H)				
Thickness Mils (ga)	Yield Strength (ksi)	6 #12 Screws, Pattern 5					6 #12 Screws, Pattern 5					10 #12 Screws, Pattern 6				
		F1 (lbs)	F2 (lbs)	F3 (lbs)	M1 (in-lbs)	Stiffness (in-lbs/rad)	F1 (lbs)	F2 (lbs)	F3 (lbs)	M1 (in-lbs)	Stiffness (in-lbs/rad)	F1 (lbs)	F2 (lbs)	F3 (lbs)	M1 (in-lbs)	Stiffness (in-lbs/rad)
33 (20)	33	286	976	1,077	2,479	190,670	286	976	1,130	2,479	548,677	381	1,664	1,884	4,710	696,515
33 (20)	50	413	1,410	1,077	2,860		413	1,410	1,633	3,582		550	2,404	2,722	6,805	
43 (18)	33	373	1,452	1,077	2,860		373	1,452	1,682	3,689		497	2,476	2,804	7,010	
43 (18)	50	538	2,098	1,077	2,860		538	2,098	2,431	5,330		718	3,577	4,051	10,128	
54 (16)	33	468	2,042	1,077	2,860		468	2,042	2,366	5,188		624	3,482	3,943	9,858	
54 (16)	50	676	2,662	1,077	2,860		676	2,950	2,666	7,493		901	5,029	5,695	11,143	
68 (14)	50	851	2,662	1,077	2,860		851	4,171	2,666	8,229		1,134	7,110	7,446	11,143	
97 (12)	50	1,214	2,662	1,077	2,860		1,214	4,398	2,666	8,229		1,618	7,497	7,446	11,143	
118 (10)	50	1,284	2,662	1,077	2,860		1,284	4,398	2,666	8,229		1,712	7,497	7,446	11,143	
Max Allowable Clip Load		1,435	2,662	1,077	2,860		3,356	6,410	2,666	8,229		4,816	8,274	7,446	11,143	

Notes:

- StiffClip CL resists vertical, horizontal, and torsional loads.
- Allowable load tables incorporate eccentric loading of fasteners. Values with welded connection may increase.
- Fasten within 3/4" from the angle heel (centerline of the 1 1/2" leg), using pre-drilled holes.
- Center hole is 0.563" in diameter for 1/2" anchor. Middle guide holes are 0.313" in diameter. Outer guide holes and guide holes in 3" leg are 0.141" in diameter.
- Guide holes are in place for fastener installation efficiency. All guide holes may not require fasteners. Fastener amount determined by the designer. Screw fasteners should be symmetrically placed in guide holes. Refer to screw pattern diagrams below for placement.
- Loads listed reflect force in a single direction. When multiple loads react on the connection, it is the responsibility of the designer to check the interaction of forces.
- Allowable loads have not been increased for wind, seismic, or other factors.
- Torsional effects are considered on screw group for F2 & F3 allowable loads. It is assumed that half of the torsional moment is taken by the connection to the structure and half is taken by the connection to the stud.
- M1 loads are reported as Max. Load divided by a Factor of Safety. M1 loads maybe limited by the Serviceability Load calculated as Clip Stiffness times the Serviceability Limit in radians.
- Stiffness is the Allowable Clip Moment divided by the clip rotation measured at Half the Max Allowable Clip Moment.

Load Direction

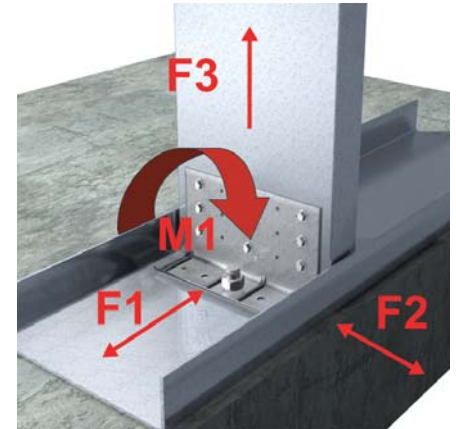

Screw Patterns

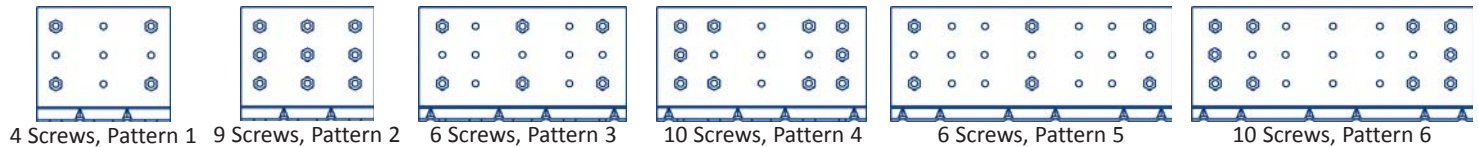

Nomenclature

To specify StiffClip CL on drawings, multiply stud depth by 100, followed by the appropriate material thickness, based on strength required (see load tables). The StiffClip CL118(H) utilizes a plate in the 1 1/2" leg (shown on page 1).

Example: 6" stud, uplift load of 650lbs

Designate: StiffClip® CL600-68

Anchor Bolt Design

The following equation for tension force in the anchor is derived using the assumed bearing stress distribution shown in the figure to the right. This assumed stress distribution provides a conservative anchor force approximation.

$$T = \frac{M}{(2/3)(d_{clip}/2)} = \frac{3M}{d_{clip}}$$

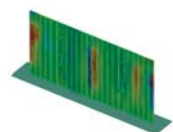
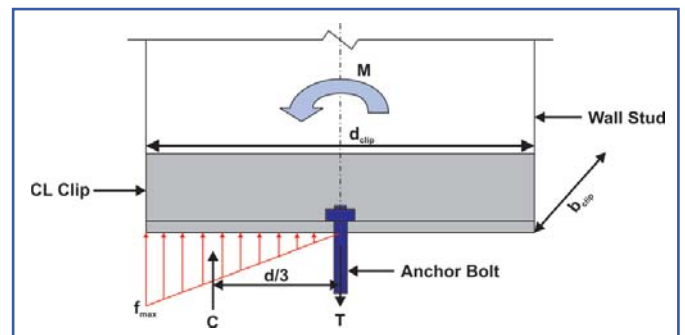

StiffClip CL Series
Blast and Seismic Design data
www.steelnetwork.com

** For more information or to review a copy of this report, please visit our website at <http://www.steelnetwork.com/Site/TechnicalData>