

# StiffClip® HC

Hip Connector

### Material Composition

ASTM A1003/A1003M Structural Grade 50 (340) Type H, ST50H (ST340H): 50ksi (340MPa) minimum yield strength, 65ksi (450MPa) minimum tensile strength, with ASTM A653/A653M G90 (Z275) hot dipped galvanized coating.

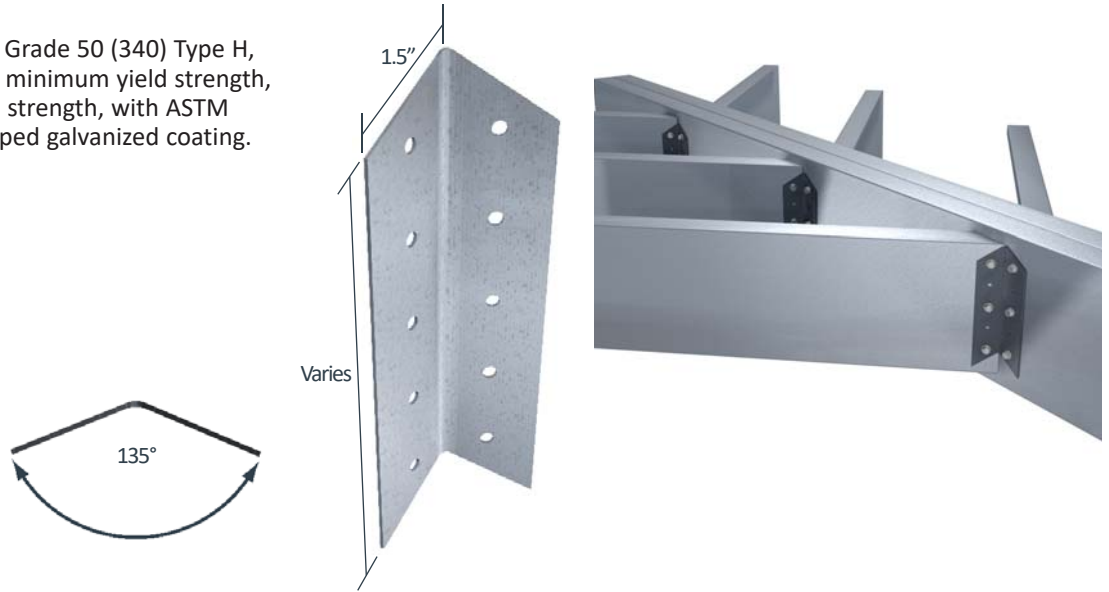

### StiffClip HC Allowable Loads

StiffClip® HC Recommended Allowable Load for a Single Clip (lbs): F3									
Joist		HC362/400-43	HC362/400-68	HC600-43	HC600-68	HC800-43	HC800-68	HC1000-68	
Thickness Mils (ga)	Yield Strength (ksi)	w/2 #12 screws	w/2 #12 screws	w/4 # 12 Screws	w/4 # 12 Screws	w/5 # 12 Screws	w/5 # 12 Screws	w/4 # 12 Screws	w/6 # 12 Screws
33 (20)	33	337	337	722	722	910	910	N/A	N/A
33 (20)	50	487	487	1,043	1,043	1,315	1,315	N/A	N/A
43 (18)	33	502	502	1,074	1,074	1,354	1,354	1,102	1,646
43 (18)	50	725	725	1,552	1,552	1,957	1,957	1,592	2,378
54 (16)	33	706	706	1,510	1,510	1,904	1,904	1,550	2,315
54 (16)	50	1,019	1,019	2,158	2,181	2,751	2,751	2,238	3,343
68 (14)	50	1,020	1,441	2,158	3,084	2,753	3,889	3,164	4,727
97 (12)	50	1,020	1,520	2,158	3,252	2,753	4,101	3,337	4,779
Max Allowable Clip Load		1,606	2,302	2,158	3,639	3,960	4,488	4,779	

Joist		HC1200-68		HC1400-68		HC1600-68	
Thickness Mils (ga)	Yield Strength (ksi)	w/6 # 12 Screws	w/8 # 12 Screws	w/5 # 12 Screws	w/9 # 12 Screws	w/6 # 12 Screws	w/10 # 12 Screws
54 (16)	33	2,342	3,111	1,956	3,509	2,346	3,908
54 (16)	50	3,383	4,493	2,825	4,560	3,389	4,560
68 (14)	50	4,560	4,560	3,994	4,560	4,560	4,560
97 (12)	50	4,560	4,560	4,211	4,560	4,560	4,560
Max Allowable Clip Load		4,560		4,560		4,560	

### Notes:

- Design loads consider loads on the clip only.
- Number of fasteners used is based on fastener manufacturer's allowable load data.
- Allowable loads have not been increased for wind, seismic, or other factors.
- All guide holes may not require fasteners. Fastener amount determined by designer.
- Torsional effects are considered on screw groups for F3 allowable loads. It is assumed that half of the torsional moment is taken by the connection to the structure and half is taken by the connection to the stud.

### Nomenclature

StiffClip HC is designated by multiplying joist depth by 100, then listing material thickness.

**Example:** 6" stud depth, 68mil steel thickness

**Designate:** StiffClip® HC600-68

\*\*Standard angle bend is 135°. Other angle shapes are available.

### Load Direction

