

# DriftClip® DSLB

Bypass Slab



## Material Composition

ASTM A1003/A1003M Structural Grade 50 (340) Type H, ST50H (ST340H): 50ksi (340MPa) minimum yield strength, 65ksi (450MPa) minimum tensile strength, 97mil minimum thickness (12 gauge, 0.1017" design thickness) with ASTM A653/A653M G90 (Z275) hot dipped galvanized coating.

The attachment of DriftClip DSLB to the primary structure may be made with PAFs, screws, or bolt anchors depending on the base material (steel or concrete) and the design configuration. The step bushings used for attachment to structure are designed for use with 1/4" maximum diameter fasteners. Designing this connection is the responsibility of the Structural Engineer of Record, and a minimum of two fasteners must be used.

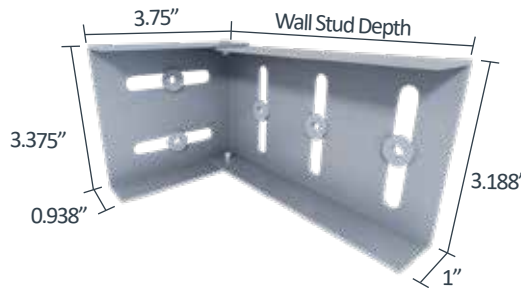

US Patent #6,612,087

## DriftClip DSLB Allowable Loads

Rigid Connection: F1, F2, & F3 Load Directions						
Screw Patterns with #12 Screws	Fastener Pattern 1			Fastener Pattern 2		
	DSLB362	DSLB600 and DSLB800		DSLB362	DSLB600 and DSLB800	
	2 Screws	2 Screws	3 Screws	2 Screws	2 Screws	3 Screws
33mil (20ga), 33ksi stud	376	376	564	377	377	565
33mil (20ga), 50ksi stud	544	544	816	544	544	572
43mil (18ga), 33ksi stud	560	560	840	561	561	572
43mil (18ga), 50ksi stud	810	810	917	572	572	572
54mil (16ga), 33ksi stud	788	788	917	572	572	572
54mil (16ga), 50ksi stud	917	917	917	572	572	572
68mil (14ga), 50ksi stud	917	917	917	572	572	572
97mil (12ga), 50ksi stud	917	917	917	572	572	572
<b>Max Allowable Clip Load</b>	<b>917</b>			<b>572</b>		

### Table Notes:

- Design loads are for attachment of DriftClip DSLB to stud only.
- Allowable loads have not been increased for wind, seismic, or other factors.
- DriftClip DSLB allows up to 2" of vertical deflection (1" up and 1" down), and 2" of lateral drift (1" left and 1" right) in plane. Deflection requirements greater than 2" of lateral drift are available.
- #12 screws are provided for each step bushing attachment to studs. Load requirements do not always require the use of a third screw.
- Attachment of structure to be engineered by others. As a design reference for the structure attachment, reference AISI S100 or screw manufacturers published data for allowable loads for screw fasteners of 1/4"-20 size with various plate thicknesses.
- One row of bridging is recommended at a maximum distance of 18" from DriftClip to resist torsional effects.
- For LRFD strengths contact TSN technical services.

### Nomenclature

DriftClip DSLB is classified by multiplying stud depth by 100.\*

**Example:** 6" stud depth

**Designate:** DriftClip® DSLB600

\* Parts with the designation "-CA" on the end of the part name includes a special bushing available to allow connection to the side of the concrete slab using two 1/4" concrete screw anchors.

\*\* If more than 2" lateral drift is required, contact TSN engineering.

## Allowable Screw Pullout

Section Thickness	Pullout 1/4" - 20 Screws*
0.0566"	261 lbs
0.0713"	328 lbs
0.1017"	468 lbs
1/8"	514 lbs
3/16"	770 lbs
1/4"	1,027 lbs
5/16"	1,284 lbs

- Limited by the allowable F2 loads shown in the table on the left
- 0.0566", 0.0713", and 0.1017" thick sections assumed to have ultimate tensile strength equal to 65 ksi.
- 1/8", 3/16", 1/4", and 5/16" thick sections assumed to have ultimate tensile strength equal to 58 ksi.
- Allowable screw pullout strengths calculated in accordance with AISI S100.

### Load Direction

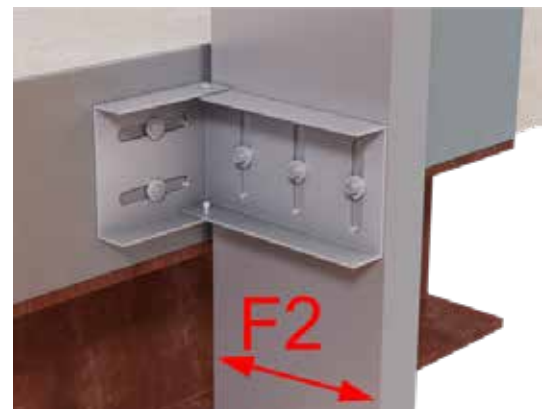

**Fastener Patterns**

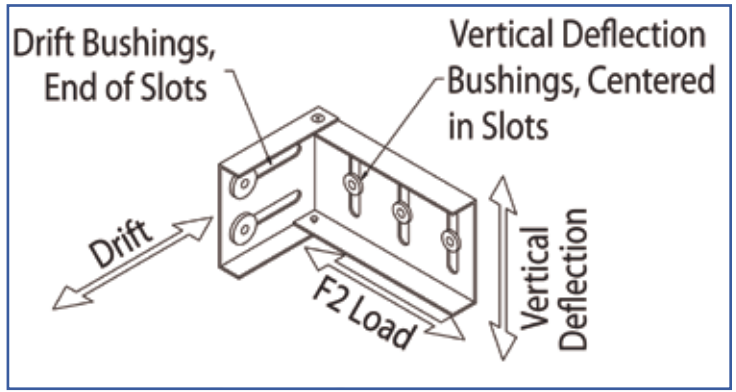
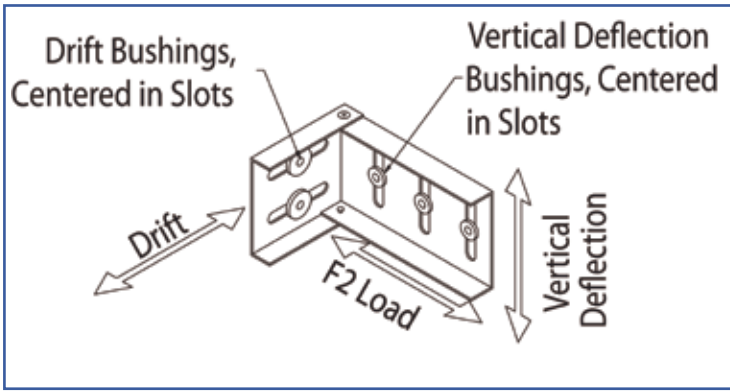

**Fastener Pattern 1** replicates a condition of out-of-plane wind or seismic force with no vertical live load deflection or in-plane drift.

**Fastener Pattern 2** replicates a condition of out-of-plane wind or seismic force with or without full vertical live load deflection and full in-plane drift.



DriftClip DSLB362/400,  
 DSLB600 & DSLB800  
 ICC-ESR-2049  
 www.icc-es.org

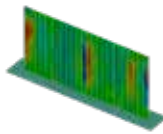

DriftClip DSLB Series  
 Blast and Seismic Design Data  
 www.steelnetwork.com

**\*\* For more information or to review a copy of each of these reports, please visit our website at <http://www.steelnetwork.com/light-steel-framing-design-resources>**