

VertiClip® SLF

Bypass Top of Slab

Material Composition

ASTM A1003/A1003M Structural Grade 50 (340) Type H, ST50H (ST340H): 50ksi (340 MPa) minimum yield strength, 65ksi (450 MPa) minimum tensile strength, 68mil minimum thickness (14 gauge, 0.0713" design thickness) with ASTM A653/653M G90 (Z275) hot dipped galvanized coating.

The attachment of VertiClip SLF to the primary structure may be made with PAFs, screw/bolt anchors or weld and is dependent upon the base material (steel or concrete) and the design configuration.

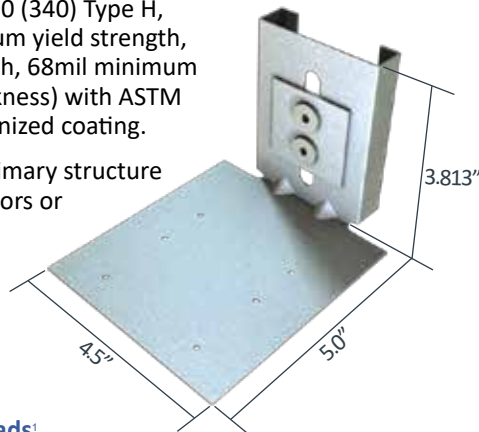

US Patent # 8,511,032

VertiClip SLF Allowable (Unfactored) Loads¹

VertiClip® SLF, Recommended Allowable Load (lbs): F2	
Screw Patterns with #12 Screws	F2 - Load Direction w/2 #12 screws
43mil (18ga), 33ksi Stud	281
43mil (18ga), 50ksi Stud	326
54mil (16ga), 33ksi Stud	401
54mil (16ga), 50ksi Stud	465
68mil (14ga), 50ksi Stud	632
97mil (12ga), 50ksi Stud	632
Maximum Allowable Clip Load	632

Load Direction



Notes:

1. VertiClip SLF is designed to support horizontal loads, and should not be used in axial load-bearing walls.
2. Allowable loads have not been increased for wind, seismic, or other factors.
3. #12 screws are provided with each step bushing for attachment to the stud web.
4. Total vertical deflection of up to 1-1/2" (3/4" up and 3/4" down).
5. Align rows of wall bridging so that one row of bridging falls within 12" from VertiClip SLF OR use one flat strap brace on outer flange of studs to resist torsional effects.
6. Stud web crippling should be checked. Use 3-1/2" bearing length and use the "Interior One Flange Reaction, Condition 2, scenario for web crippling calculations. If justified, using the "End One Flange Reaction, Condition 1, scenario is acceptable.
7. For LRFD strengths contact TSN technical services.

Nomenclature

VertiClip SLF is available in one size for all stud depths with 1 5/8" flanges and is designated *VertiClip® SLF162*

* *VertiClip SLF for use with 2" stud flanges can be made as a custom part.*

Example Details



VertiClip SLF used with TSN's BridgeBar® & BridgeClip® installed within 12" from the clip.



VertiClip SLF used with one flat strap brace on the outer flange of studs to resist torsional effects.