

- Authorities Having Jurisdiction should be consulted in all cases as to the particular requirements covering the installation and use of tested products and materials.
- Authorities Having Jurisdiction should be consulted before construction.
- Fire resistance assemblies and products have been investigated for compliance with applicable requirements. Compliance test reports are available upon request. The published information cannot always address every construction nuance encountered in the field.
- When field issues arise, it is recommended to contact TSN technical service staff.

Fire Resistance Ratings – ASTM E119 (UL 263)

Design No. **GC001**

Rating – 1 Hr

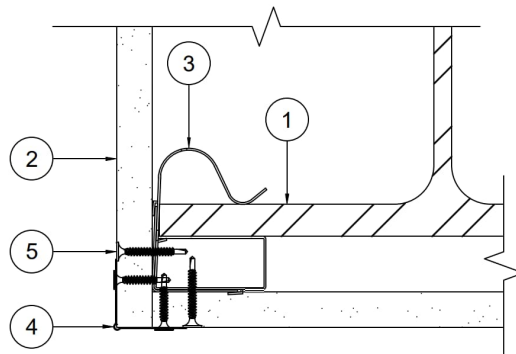

**CORNER DETAIL OF WALLBOARD
 SUPPORT SYSTEM WITHOUT STEEL COVERS**

1. **Steel Column** – Min. size of W-shaped steel column which appears in the AISC Steel Construction Manual to be W10x49.
2. **Gypsum Board** – Any nominal 5/8” thick Core Type X gypsum board applied in single layer as noted in above illustration.
3. **Framing Members** – TSN GripClip® spaced 4’ 0” o.c. vertically and 1-1/4” from top and bottom of column. L1-1/2” x 1-1/2” – 33mil steel support angles shall be clipped into GripClip tabs. Splices in angle to occur over clips.
4. **Corner Bead** – No. 28 MSG galvanized steel, 1-1/4” legs to be attached to the wallboard with No. 6 by 1” screws spaced 12” o.c. max.
5. **Screws** – For attaching single layer of wallboard to steel angles to be No. 6 x 1-1/4” Phillips head self-drilling, self tapping double lead screws spaced 24” o.c.
6. **Finishing System** – (Not Shown) – Joint compound applied over corner beads to a thickness of 1/16”.