

QUALITY LIGHT STEEL FRAMING CONNECTIONS AND MEMBERS

# LIGHT STEEL FRAMING CONNECTIONS

INTERIOR • EXTERIOR • VERTICAL DEFLECTION • DRIFT



STEELNETWORK.COM  
1.888.474.4876

# Light Steel Framing Connections

## Table of Contents

General Product Information.....	2
Building Load Paths.....	3
Movement-Allowing Connectors/Step Bushing Technology®.....	4
<b>Vertical Deflection: Head Of Wall Connectors</b>	
VertiTrack® VTD (Interior).....	5-6
VertiTrack® VTX (Exterior).....	7-8
VertiClip® SLD (Interior).....	9-10
VertiClip® SL (Exterior).....	11-12
VertiClip® SLD w/ 3" Slots (Interior).....	13
VertiClip® SL w/ 3" Slots (Exterior).....	14
<b>Vertical Deflection: Bypass Connectors</b>	
VertiClip® SLS (Bypass Structure).....	15-16
VertiClip® SLB (Bypass Slab).....	17-18
VertiClip® SLB-HD (Seismic Bypass Slab).....	19
VertiClip® SLF (Bypass Slab - Panels).....	20
VertiClip® SLT (Structure/Slab Bypass).....	21-22
<b>Hybrid Vertical Deflection &amp; Rigid Connectors</b>	
MasterClip® VLB (Bypass Slab).....	23-24
<b>Drift and Vertical Deflection Connectors</b>	
DriftClip® DSLB (Bypass Slab).....	25-26
DriftClip® DSLS (Bypass Structure).....	27-28
DriftClip® DSLD (Interior Head of Wall).....	29-30
DriftClip® DSL (Exterior Head of Wall).....	31-32
DriftTrak® DT w/ DTSL (Exterior Head of Wall).....	33-34
DriftTrak® DT w/ DTSLB (Exterior Bypass).....	35-36
DriftTrak® DT w/ DTSLB-HD (Bypass Slab).....	37-38
DriftTrak® DT w/ DTLB (Exterior Bypass).....	39-40
DriftTrak® DT w/ DTLB-HD (Bypass Slab).....	41-42
DriftTrak® DTH w/ DTSLB-HD (Slab Integrated Bypass).....	43-44
DriftTrak® DTH w/ DTLB-HD (Slab Integrated Bypass).....	45-46
DriftTrak® PTS w/ DTSLB-PTS (Slab Integrated Bypass - Post Tensioned Concrete Slabs).....	47-48
DriftTrak® PTS w/ DTLB-PTS (Slab Integrated Bypass - Post Tensioned Concrete Slabs).....	49-50
<b>Wall Bridging Connectors</b>	
Wall Bridging (Background).....	52
Curtain Wall Bridging Reference Chart.....	53-56
Wall Bridging Anchorage.....	57
BridgeClip® (Secures Channel to Stud).....	58
BridgeBar® (Bridging Channel).....	59
BuckleBridge® (Bridging System).....	60
<b>Rigid Wall Connectors</b>	
StiffClip® LB (Spandrel Bypass).....	61-62
StiffClip® LB-HD (Seismic Spandrel Bypass).....	63
VertiClip® Splice (Multi-Stud Clip).....	64
StiffClip® CL (Tie-Down).....	65-68
MidWall™ (Partial Wall Framing).....	69-70
StiffClip® TD (Tie-Down).....	71-74
StiffClip® PLC (Panel Lift Clip).....	75-76
StiffClip® HE (Header Clip).....	77-78
StiffClip® HS (Jamb Stud Header and Sill Connector).....	79
<b>Rigid Roof &amp; Truss Connectors</b>	
StiffClip® HC (Hip Connector).....	80
StiffClip® RT (Roof Tie).....	81-82
StiffClip® WC (Web Connector).....	83-84
StiffClip® PL (Truss Connector).....	85
<b>Floor Connectors</b>	
StiffClip® JH (Joist Hanger).....	86
StiffClip® JC (Joist Clip).....	87
StiffClip® FS (Floor Strap).....	88
<b>All-Purpose Rigid Connectors &amp; Specialty Products</b>	
StiffClip® AL (Multi-Purpose).....	89-90
StiffClip® LS (Spandrel/Multi-Purpose).....	91
CircleTrak® (Curved Wall Track).....	92
NotchTrak® NT (Wall Backing/Bridging).....	93-94
BackIt® (Wall Backing).....	95
GripClip® (Column/Beam Connector).....	96
Common Clip Angle.....	97
Custom Connectors.....	98
<b>Special Design Requirements</b>	
Blast & Seismic Design Load Tables.....	99-102
Building Codes & Fire Ratings.....	103

# General Product Information

## Introduction

The Steel Network provides solutions for all standard light steel framing configurations. Substantial effort has been made by the industry to standardize construction practices to ensure the positive connections of light steel framing components. Toward this end, TSN products have undergone extensive field and laboratory testing to achieve complete solutions for both designers and installers.

- Attachment of connections to the primary structure should be engineered by a design professional. Listed allowable loads are based on tests with full attachment to primary structure through all guide holes where applicable.
- Prying action on the attachment to the structure should be considered where eccentricity exists between the fastener and the load.
- Test reports are available through The Steel Network, Inc. Contact TSN at (888) 474-4876 for more information.
- The Steel Network, Inc. offers all products and services through local authorized distributors.
- Products are manufactured from recycled steel.
- The installation contractor is responsible for installing products in accordance with the instructions listed in this catalog and included with the shipped product, in addition to any relevant specifications and building codes. Install connectors prior to loading.
- Custom products are available upon request. Prior approval must be obtained and the order shall be submitted with a signed engineered drawing.
- Allowable loads and material data listed in this catalog supersede all information in all earlier publications.
- Self-drilling screws should be installed perpendicular to the work surface. #8 and #10 self-drilling screws should be installed with a screw gun limited to no more than 2,500 rpm. #12 self-drilling screws should be installed with a screw gun limited to no more than 1,800 rpm.
- The screw gun must also feature a torque limiting nose piece to avoid over-driving the screw. Over-driving can damage the fastener by stripping the threads or shearing the fastener head and may cause failure even when not visually detected.
- Allowable loads have not been increased for wind, seismic, or other factors.
- Loads are determined using "Allowable Stress Design" (ASD) method. When LRFD (Load and Resistance Factor Design) is utilized, contact TSN for appropriate resistance values.
- Products are tested according to the guidelines listed in the AISI S100 Specification for the Design of Cold Formed Steel Structures, Section K, and ICC Criteria AC261, where applicable.
- Allowable loads are based on the lesser of: (a) Average test ultimate load divided by the appropriate factor of safety, (b) Load producing deflection value of 0.125" for vertical deflection products and 0.1875" or drift products, or (c) Fastener/screw allowable load between the clip & stud.
- Allowable loads are the result of static testing by either independent testing facilities or in-house testing and calculations.
- Allowable loads are the maximum forces resisted in one direction only. When multiple loads effect a connection: Designer of record is responsible for checking the interaction of multiple loads acting on a connection.
- Screw connection allowable loads are based on AISI-S100 design specification, Sec. J4, and are limited by these allowable loads: 717 lbs for #12 Shear, 548 lbs for #10 Shear, 400 lbs for #8 Shear, 494 lbs for #12 Pullout, 435 lbs for #10 Pullout, 375 lbs for #8 Pullout.
- Where screw torsion is considered, it is assumed that half of the torsional moment is taken by the connection to the structure and half is taken by the connection to the stud, unless stated otherwise.



# SteelSmart System 8

With 2021 IBC & ASCE 7-16

The industry's #1 tool for the design of Connections, Members, Fasteners & Details

**COMPONENT DESIGN MODULES:**

- Curtain Wall
- Load Bearing Wall
- X-Brace Shear Wall
- Floor Framing
- Roof Framing & Trusses
- Moment Resisting Short Wall

**ORDER ONLINE**  
[www.steelSMARTsystem.com](http://www.steelSMARTsystem.com)

# Building Load Paths

## Introduction



### Background

There are two types of light steel framing connections, fixed and movement-allowing. Fixed connections of framing members are found in many types of assemblies, including axial-load-bearing walls, curtain walls, trusses, roofs, and floors. As light steel framing (LSF) assemblies are only as strong as their weakest component, The Steel Network has developed products to provide designers and installers with tested, certified, and traceable materials for light steel framing assemblies.

Tracing a consistent load and movement path from the roof to the foundation is much simpler through use of The Steel Network's connectors. TSN products are engineered to provide the most efficient load transfer path for the designer while adding economic value for the contractor.

When considering safety and liability, connections should not be the weakest part of the assembly. Use of generic material raises questions about performance. Is the steel material traceable? Is the material sufficiently galvanized? Has the material been structurally load tested? These questions should not go unanswered in today's construction practice. The Steel Network provides mill certified and tested steel, galvanized with coating meeting or exceeding industry standards. TSN products have undergone extensive field and laboratory testing to achieve complete solutions for both designers and installers, enabling them to trace the most efficient load and movement paths through the structure. When it comes to connections and members, TSN is setting the industry standard.

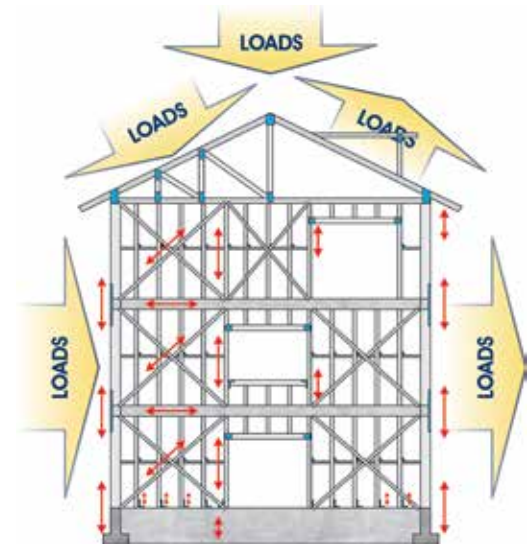

### Load Directions

Connection loads have been determined through structural testing based on guidelines set forth by the AISI Specification. A diagram of load directions for each clip is located with the respective product load tables. Load direction nomenclature is consistent throughout this catalog. The diagrams at right illustrate examples of load directions used in this catalog.

**F1** = Lateral (In the plane of the wall), lbs

**F2** = Horizontal Load (Out of the plane of the wall), lbs

**F3** = Vertical Load (or Uplift), lbs

**M1** = Moment-Carrying (or Rotational), in-lbs

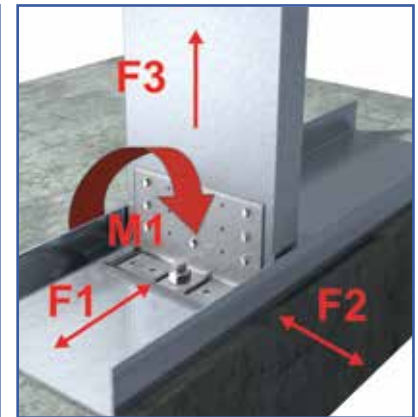
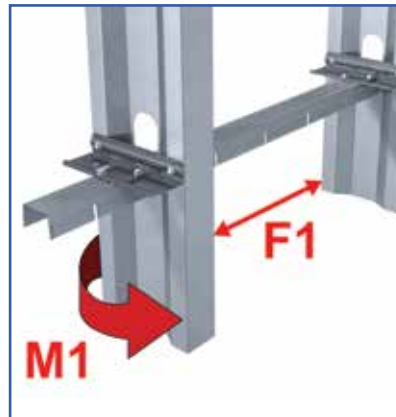

In addition, connectors are available to resist axial tension and compression in a flat plane.

### Industry Improvements

The Steel Network's series of connectors utilizes tested, mechanical configurations to resist many different types of load (gravity, in-plane, out-of-plane, moment-carrying, axial tension and compression in a flat plane). Each is available in a wide range of sizes and applications to meet all standard construction needs. Additionally, custom clips may be designed and produced for specific applications.

The Steel Network delivers a comprehensive improvement to the industry by:

- Providing simple, labor-saving solutions for all steel framing attachments to primary frames.
- Placing pre-drilled guide holes for quick and accurate fastener placement.
- Producing connections tested under AISI guidelines.
- Manufacturing from ASTM A1003 steel with hot-dipped galvanized G90 coating guaranteeing longterm durability and performance.
- Eliminating use of untested, untraceable, steel for connections.

### Stiffened Plate Elements

Most TSN connection products are manufactured with stiffeners, as bending forces are present when loads are transferred from the framing member to the structure. Stiffeners increase the capacity of flat elements to resist bending, thus maximizing material efficiency.



# Movement-Allowing Connectors

## Introduction

### Primary Structural Deflection

All structures deflect vertically. To prevent non-axial-load-bearing studs from carrying the weight of the structure and to protect finishes, vertical deflection connections should be incorporated at the earliest possible moment of project design. The load-carrying capacity of a steel stud in bending is reduced significantly when adding an axial force propagated by the bending of a primary beam or slab. VertiClip® products were developed to prevent the crushing effect on non-axial-load-bearing wall studs. Non-axial-load-bearing wall studs include exterior curtain wall and interior wall assemblies. When project conditions dictate, lateral drift and vertical deflection may be accommodated through utilization of TSN's DriftClip® and DriftTrak® lines of connectors.

Finished walls frequently experience cracking, buckling, or crushing due to improper isolation of building movement. The movement of the primary building structure is largely accounted for in horizontal member live loading. In addition to live loads, wind, seismic forces, moisture content in materials, and temperature cycles all contribute to movement. The incorporation of vertical deflection connections during the working drawing phase will eliminate the liability of failures and added costs associated with wall system installation.

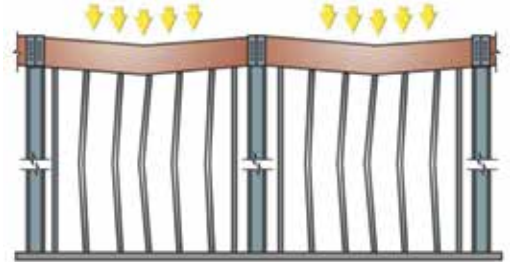

### Specifying Deflection Distances

Deflection distances are determined from movement of the primary frame, roof, and floor slab. Designers of non-axial-load-bearing framing typically allow for a minimum of 1/2" (13mm) of vertical deflection. When specifying vertical deflection distances, consider the following example -- the deflection distance may be derived using a column spacing of 20 feet on center and a maximum deflection of L/480, thereby resulting in a vertical deflection value equal to .5". Deflection distances may range from 0.125" in very heavy rigid structures to 6" in lightweight open frames.

## Step Bushing Technology®

### Innovation

#### Shear Transfer

Non-axial-load-bearing walls are not designed to carry the structure, but horizontal loads from wind and seismic forces are transferred from the exterior finishes through wall framing to the primary structure. VertiClip and DriftClip effectively transfer the shear load from the stud to the primary member by connecting to the stud web.

The image on the right illustrates the horizontal load path. The load transitions into shear at the VertiClip to stud web attachment. VertiClip prevents the track flange from bending and stiffens the stud web.

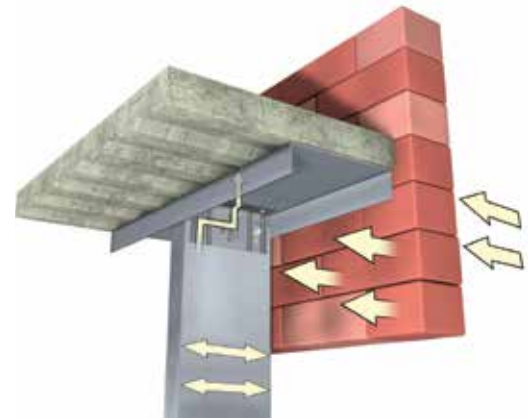

#### Step Bushing Technology®

Step Bushing Technology provides a solid and simple solution for accommodating vertical deflections in the primary structural components of a building. Step bushings are pre-installed at the center of elongated slots in the connectors to allow for this vertical movement. A VertiClip or DriftClip attaches mechanically to the stud web through the Step Bushings with self-drilling screws provided with each clips.

The Step Bushing allows horizontal loads to transfer from the stud web into the structure through a positive, mechanical attachment, while simultaneously allowing friction-free vertical movement. TSN's solutions replace friction-held configurations and flange gripping devices, further reducing liability concerns.

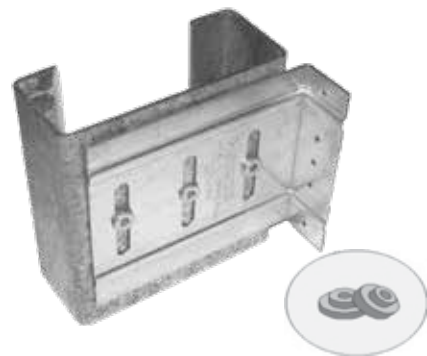

VertiClip SLB showing Step Bushings, which are pre-installed at the center of each slot and placed in position at the factory for quality assurance and ease of installation.



Step Bushings transfer the shear load at the stud web through connector into the primary structure.

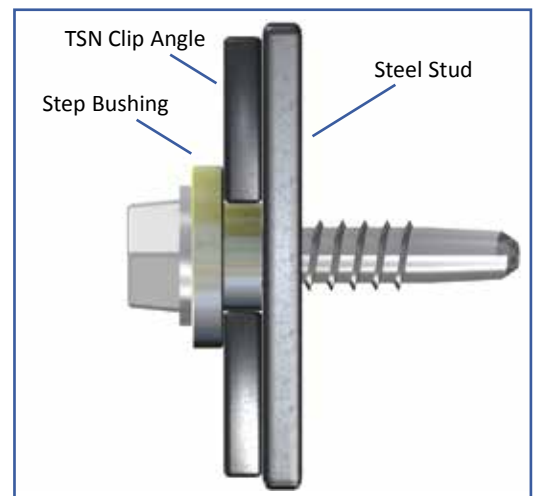

Step Bushings are seated inside slots of the VertiClips. Since Step Bushings are slightly thicker than the steel material, they provide a positive mechanical attachment to the stud web and allow for deflection movement.

# VertiTrack® VTD

Interior Head of Wall

### Material Composition

**Clip Material:** ASTM A1003/A1003M Structural Grade 50 (340) Type H, ST50H (ST340H): 50ksi (340MPa) minimum yield strength, 65ksi (450MPa) minimum tensile strength, 33mil minimum thickness (20 gauge, 0.0346" design thickness) with ASTM A653/A653M G60 (Z180) hot dipped galvanized coating.

**Track Material:** ASTM A1003/A1003M Structural Grade 33 (230) Type H, ST33H (ST230H): 33ksi (230MPa) minimum yield strength, 45ksi (310MPa) minimum tensile strength, 33mil minimum thickness (20 gauge, 0.0346" design thickness) with ASTM A653/A653M G60 (Z180) hot dipped galvanized coating.

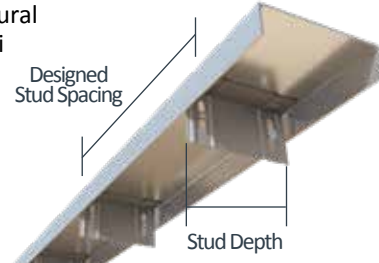

\*Track leg length = 1.5".



US Patents #5,467,566 & #5,906,080

The attachment of VertiTrack VTD to the primary structure may be made with PAFs or screw/bolt anchors and is dependent upon the base material (steel or concrete) and the design configuration.

### VertiTrack VTD Allowable (Unfactored) Loads<sup>1</sup>

VertiTrack® VTD, Recommended Allowable Load (lbs): F2 (VertiClip® SLD Loads)				
	F2 - Deflection Connection			
	VTD250	VTD362/400	VTD600	VTD800
Screw Patterns with #8 Screws	w/2 #8 screws	w/2 #8 screws	w/2 #8 screws	w/2 #8 screws
18mil (25ga), 33ksi Stud	132	132	132	132
27mil (22ga), 33ksi Stud	159	242	242	242
30mil (20ga-Drywall), 33ksi Stud	159	322	322	322
33mil (20ga-Structural), 33ksi Stud	159	328	328	328
33mil (20ga), 50ksi Stud	159	359	405	474
43mil (18ga), 33ksi Stud	159	359	405	488
43mil (18ga), 50ksi Stud	159	359	405	664
54mil (16ga), 33ksi Stud	159	359	405	664
54mil (16ga), 50ksi Stud	159	359	405	664
<b>Maximum Allowable Clip Load</b>	<b>159</b>	<b>359</b>	<b>405</b>	<b>682</b>

### Load Direction



### Notes:

1. VertiTrack VTD loads are the same as VertiClip SLD.
2. VertiTrack VTD is assembled with the VertiClip SLD pre-attached at 16" o.c. or 24" o.c.
3. VertiTrack VTD is designed to support horizontal loads, and should not be used in axial load-bearing walls.
4. Allowable loads have not been increased for wind, seismic, or other factors.
5. Strengthening ribs are present in 3-5/8" and 6" sizes.
6. #8 screws are provided with each step bushing for attachment to the stud web.
7. Fasten through each Verticlip SLD to structure.
8. Fasten within 3/4" of the angle heel (centerline of the 1-1/2" leg) to minimize eccentric load transfer.
9. Total vertical deflection of up to 1-1/2" (3/4" up and 3/4" down). Deflection requirements greater than 3/4" (up and down) are available. Custom spacing is also available.
10. For LRFD strengths contact TSN technical services.

**Nomenclature**

VertiTrack VTD is manufactured in 12 ft. lengths. VertiTrack is designated by type (VTD), followed by stud depth in inches multiplied by 100 and the stud spacing.

**Example:** 6" deep stud, 16" on center

**Designate:** VertiTrack® VTD600-16



UL®-Classified Head of Wall Assemblies

HW-D-0003, HW-D-0024, HW-D-0025, HW-D-0036, HW-D-0042, HW-D-0043, HW-D-0044, HW-D-0045, HW-D-0046, HW-D-0047, HW-D-0048, HW-D-0049, HW-D-0054, HW-D-0062, HW-D-0063, HW-D-0066, HW-D-0067, HW-D-0068, HW-D-0069, HW-D-0071, HW-D-0072, HW-D-0073, HW-D-0076, HW-D-0077, HW-D-0082, HW-D-0083, HW-D-0084, HW-D-0085, HW-D-0087, HW-D-0089, HW-D-0091, HW-D-0102, HW-D-0106, HW-D-0152, HW-D-0154, HW-D-0160, HW-D-0162, HW-D-0167, HW-D-0184, HW-D-0185, HW-D-0186, HW-D-0190, HW-D-0193, HW-D-0209, HW-D-0218, HW-D-0246, HW-D-0256, HW-D-0259, HW-D-0263, HW-D-0271, HW-D-0272, HW-D-0275, HW-D-0277, HW-D-0278, HW-D-0280, HW-D-0293, HW-D-0299, HW-D-0310, HW-D-0313, HW-D-0321, HW-D-0322, HW-D-0324, HW-D-0341, HW-D-0342, HW-D-0353, HW-D-0356, HW-D-0357, HW-D-0358, HW-D-0363, HW-D-0365, HW-D-0368, HW-D-0370, HW-D-0371, HW-D-0401, HW-D-0404, HW-D-0420, HW-D-0421, HW-D-0453, HW-D-0455, HW-D-0460, HW-D-0461, HW-D-0462, HW-D-0463, HW-D-0466, HW-D-0468, HW-D-0470, HW-D-0475, HW-D-0477, HW-D-0483, HW-D-0491, HW-D-0526, HW-D-0527, HW-D-0532, HW-D-0545, HW-D-0639, HW-D-0642, HW-D-0644, HW-D-0645, HW-D-0646, HW-D-0687, HW-D-0689, HW-D-0695, HW-D-0696



VertiClip SLD600  
ICC-ESR-2049  
[www.icc-es.org](http://www.icc-es.org)



Meets criteria for New York MEA 326-06-M

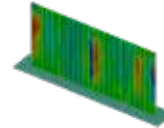

VertiClip SLD Series  
Blast and Seismic Design Data  
[www.steelnetwork.com](http://www.steelnetwork.com)

**\*\* For more information or to review a copy of each of these reports, please visit our website at <http://www.steelnetwork.com/light-steel-framing-design-resources>**

# VertiTrack® VTX

Exterior Head of Wall

### Material Composition

**Clip Material:** ASTM A1003/A1003M Structural Grade 50 (340) Type H, ST50H (ST340H): 50ksi (340MPa) minimum yield strength, 65ksi (450MPa) minimum tensile strength, 68mil minimum thickness (14 gauge, 0.0713" design thickness) with ASTM A653/A653M G90 (Z275) hot dipped galvanized coating.

**Track Material:** ASTM A1003/A1003M Structural Grade 33 (230) Type H, ST33H (ST230H): 33ksi (230MPa) minimum yield strength, 45ksi (310MPa) minimum tensile strength, 43mil minimum thickness (18 gauge, 0.0451" design thickness) with ASTM A653/A653M G60 (Z180) hot dipped galvanized coating.

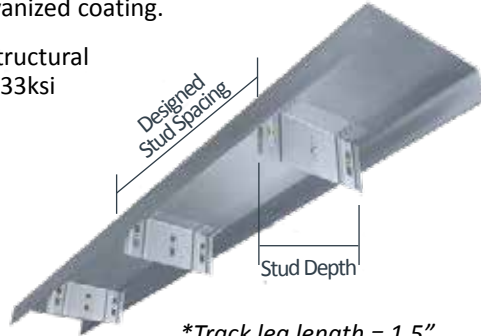

\*Track leg length = 1.5".



US Patents #5,467,566 & #5,906,080

The attachment of VertiTrack VTX to the primary structure may be made with PAFs, screw/bolt anchors or weld and is dependent upon the base material (steel or concrete) and the design configuration.

### VertiTrack VTX Allowable (Unfactored) Loads<sup>1</sup>

VertiTrack® VTX, Recommended Allowable Load (lbs): F1 & F2 (VertiClip® SL Loads)												
Screw Patterns with #12 Screws	F1 Load Direction						F2 Load Direction					
	VTX362	VTX400	VTX600		VTX800		VTX362	VTX400	VTX600		VTX800	
	w/2 #12 screws	w/2 #12 screws	w/2 #12 screws	w/3 #12 screws	w/2 #12 screws	w/3 #12 screws	w/2 #12 screws	w/2 #12 screws	w/2 #12 screws	w/3 #12 screws	w/2 #12 screws	w/3 #12 screws
33mil (20ga), 33ksi Stud	190	190	190	285	190	285	376	376	376	564	376	564
33mil (20ga), 50ksi Stud	248	199	276	368	276	362	544	544	544	816	544	816
43mil (18ga), 33ksi Stud	248	199	248	368	248	362	560	560	560	840	560	840
43mil (18ga), 50ksi Stud	248	199	358	368	358	362	787	810	810	1,215	810	1,215
54mil (16ga), 33ksi Stud	248	199	312	368	312	362	787	788	788	1,182	788	1,182
54mil (16ga), 50ksi Stud	248	199	368	368	362	362	787	1,136	1,138	1,680	1,138	1,707
68mil (14ga), 50ksi Stud	248	199	368	368	362	362	787	1,136	1,434	1,680	1,434	1,870
97mil (12ga), 50ksi Stud	248	199	368	368	362	362	787	1,136	1,434	1,680	1,434	1,870
<b>Max Allowable Clip Load</b>	<b>248</b>	<b>199</b>	<b>368</b>		<b>362</b>		<b>787</b>	<b>1,136</b>	<b>1,680</b>		<b>1,870</b>	

### Notes:

1. VertiTrack VTX loads are the same as VertiClip SL.
2. VertiTrack VTX is assembled with the VertiClip SL pre-attached at 16" o.c. or 24" o.c.
3. VertiTrack VTX is designed to support horizontal loads, and should not be used in axial load-bearing walls.
4. Allowable loads have not been increased for wind, seismic, or other factors.
5. Strengthening ribs are present in 3-5/8" and 6" sizes.
6. #12 screws are provided with each step bushing for attachment to the stud web.
7. Fasten through each Verticlip SL to structure.
8. Fasten within 3/4" of the angle heel (centerline of the 1-1/2" leg) to minimize eccentric load transfer.
9. Total vertical deflection of up to 1-1/2" (3/4" up and 3/4" down). Deflection requirements greater than 3/4" (up and down) are available. Custom spacing is also available.
10. Allowable load tables incorporate eccentric loading of fasteners. Values with welded connection may increase.
11. For LRFD strengths contact TSN technical services.

### Load Direction

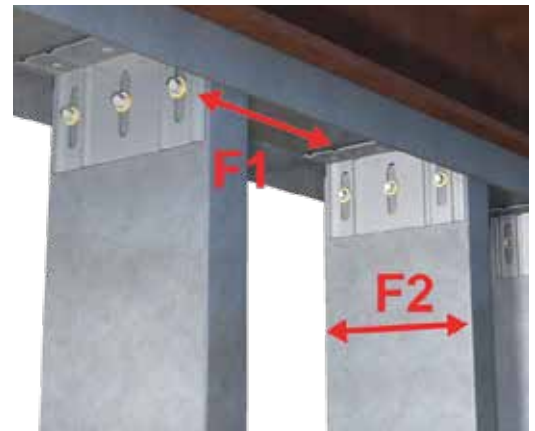

**Nomenclature**

VertiTrack VTX is manufactured in 12 ft. lengths. VertiTrack is designated by type (VTX), followed by stud depth in inches multiplied by 100 and the stud spacing.

**Example:** 6" deep stud, 16" on center

**Designate:** VertiTrack® VTX600-16



UL®-Classified Head of Wall Assemblies

HW-D-0003, HW-D-0024, HW-D-0025, HW-D-0036, HW-D-0042, HW-D-0043, HW-D-0044, HW-D-0045, HW-D-0046, HW-D-0047, HW-D-0048, HW-D-0049, HW-D-0054, HW-D-0062, HW-D-0063, HW-D-0066, HW-D-0067, HW-D-0068, HW-D-0069, HW-D-0071, HW-D-0072, HW-D-0073, HW-D-0076, HW-D-0077, HW-D-0082, HW-D-0083, HW-D-0084, HW-D-0085, HW-D-0087, HW-D-0089, HW-D-0091, HW-D-0102, HW-D-0106, HW-D-0152, HW-D-0154, HW-D-0160, HW-D-0162, HW-D-0167, HW-D-0184, HW-D-0185, HW-D-0186, HW-D-0190, HW-D-0193, HW-D-0209, HW-D-0218, HW-D-0246, HW-D-0256, HW-D-0259, HW-D-0263, HW-D-0271, HW-D-0272, HW-D-0275, HW-D-0277, HW-D-0278, HW-D-0280, HW-D-0293, HW-D-0299, HW-D-0310, HW-D-0313, HW-D-0321, HW-D-0322, HW-D-0324, HW-D-0341, HW-D-0342, HW-D-0353, HW-D-0356, HW-D-0357, HW-D-0358, HW-D-0363, HW-D-0365, HW-D-0368, HW-D-0370, HW-D-0371, HW-D-0401, HW-D-0404, HW-D-0420, HW-D-0421, HW-D-0453, HW-D-0455, HW-D-0460, HW-D-0461, HW-D-0462, HW-D-0463, HW-D-0466, HW-D-0468, HW-D-0470, HW-D-0475, HW-D-0477, HW-D-0483, HW-D-0491, HW-D-0526, HW-D-0527, HW-D-0532, HW-D-0545, HW-D-0639, HW-D-0642, HW-D-0644, HW-D-0645, HW-D-0646, HW-D-0687, HW-D-0689, HW-D-0695, HW-D-0696



VertiClip SL362, SL600 & SL800  
 ICC-ESR-2049  
[www.icc-es.org](http://www.icc-es.org)

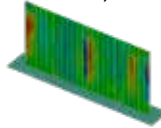

VertiClip SL Series  
 Blast and Seismic Design Data  
[www.steelnetwork.com](http://www.steelnetwork.com)

\* For more information or to review a copy of each of these reports, please visit our website at <http://www.steelnetwork.com/light-steel-framing-design-resources>

# VertiClip® SLD

Interior Head of Wall

### Material Composition

ASTM A1003/A1003M Structural Grade 50 (340) Type H, ST50H (ST340H): 50ksi (340MPa) minimum yield strength, 65ksi (450MPa) minimum tensile strength, 33mil minimum thickness (20 gauge, 0.0346" design thickness) with ASTM A653/A653M G60 (Z180) hot dipped galvanized coating.

The attachment of VertiClip SLD to the primary structure may be made with PAFs or screw/bolt anchors and is dependent upon the base material (steel or concrete) and the design configuration.

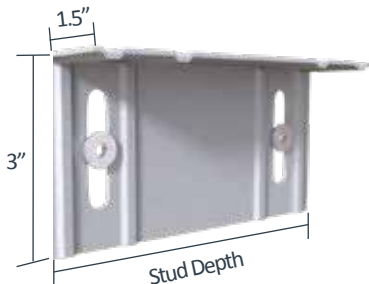

US Patents #5,467,566 & #5,906,080

### VertiClip SLD Allowable (Unfactored) Loads<sup>1</sup>

VertiClip® SLD, Recommended Allowable Load (lbs): F2					
Screw Patterns with #8 Screws	F2 - Deflection Connection				
	SLD150	SLD250	SLD362/400	SLD600	SLD800
	w/1 #8 screw	w/2 #8 screws	w/2 #8 screws	w/2 #8 screws	w/2 #8 screws
18mil (25ga), 33ksi Stud	51	132	132	132	132
27mil (22ga), 33ksi Stud	51	159	242	242	242
30mil (20ga-Drywall), 33ksi Stud	51	159	322	322	322
33mil (20ga-Structural), 33ksi Stud	51	159	328	328	328
33mil (20ga), 50ksi Stud	51	159	359	405	474
43mil (18ga), 33ksi Stud	51	159	359	405	488
43mil (18ga), 50ksi Stud	51	159	359	405	664
54mil (16ga), 33ksi Stud	51	159	359	405	664
54mil (16ga), 50ksi Stud	51	159	359	405	664
<b>Maximum Allowable Clip Load</b>	<b>51</b>	<b>159</b>	<b>359</b>	<b>405</b>	<b>682</b>

### Load Direction



### Notes:

1. VertiClip SLD is designed to support horizontal loads, and should not be used in axial load-bearing walls.
2. Allowable loads have not been increased for wind, seismic, or other factors.
3. Strengthening ribs are present in 3-5/8" and 6" sizes.
4. #8 screws are provided with each step bushing for attachment to the stud web.
5. Guide holes for attachment to structure are 0.141" diameter for SLD362/400 and SLD600. Guideholes are not standard for other clip sizes.
6. Fasten within 3/4" of the angle heel (centerline of the 1-1/2" leg) to minimize eccentric load transfer.
7. Total vertical deflection of up to 1-1/2" (3/4" up and 3/4" down). Deflection requirements greater than 3/4" (up and down) are available
8. For LRFD strengths contact TSN technical services.

### Nomenclature

VertiClip SLD is designated by type (SLD), followed by stud depth in inches multiplied by 100.

**Example:** 6" stud  
**Designate:** VertiClip® SLD600

### Shaft Wall

VertiClip SLD may be used in shaft wall assemblies to provide a positive attachment at the top of wall. Sizes include VertiClip SLD150, SLD250, and SLD362 for 2.5", 4", and 6" shaft wall stud depths.



UL2079 & UL®-Classified  
WR Grace shaft wall  
assembly HW-D-0401.



When to Use VertiClip SLD and VertiClip SL

		When to Use VertiClip® SLD and VertiClip® SL																	
Wind Pressure		20 psf				25 psf				30 psf				40 psf					
Deflection Limit		L/360		L/600		L/360		L/600		L/360		L/600		L/360		L/600			
Stud Spacing		16" o.c.	24" o.c.	16" o.c.	24" o.c.	16" o.c.	24" o.c.	16" o.c.	24" o.c.	16" o.c.	24" o.c.	16" o.c.	24" o.c.	12" o.c.	16" o.c.	12" o.c.	16" o.c.		
362/400 Stud Depth	Wall Height (ft)	9'	SLD	SLD	SLD	SL	SLD	SLD	SLD	SL	SLD	SLD	SL	SL*	SLD	SLD	SL	SL	
		10'	SLD	SLD	SL	SL	SLD	SL	SL	SL*	SLD	SL	SL	SL*	SLD	SL	SL	SL*	
		12'	SL	SL*	SL*	SL*	SL	SL*	SL*	SL*	SL*	SL*	SL*	SL*	SL*	SL*	SL*	SL*	SL*
		15'	SL*	SL*	SL*	SL*	SL*	SL*	SL*	SL*	SL*	SL*	SL*	SL*	SL*	SL*	SL*	SL*	SL*
600 Stud Depth	Wall Height (ft)	9'	SLD	SLD	SLD	SLD	SLD	SLD	SLD	SLD	SLD	SLD	SLD	SLD	SLD	SLD	SLD	SLD	
		10'	SLD	SLD	SLD	SLD	SLD	SLD	SLD	SLD	SLD	SLD	SLD	SLD	SLD	SLD	SLD	SLD	
		12'	SLD	SLD	SLD	SLD	SLD	SLD	SLD	SLD	SLD	SLD	SLD	SLD	SLD	SLD	SLD	SLD	
		15'	SLD	SLD	SL	SL	SLD	SL	SL	SLD	SL	SL	SLD	SL	SL*	SLD	SL	SL	SL*
		18'	SL	SL	SL	SL*	SL	SL	SL*	SL*	SL	SL*	SL*	SL*	SL*	SL	SL*	SL*	SL*
		21'	SL	SL*	SL*	SL*	SL*	SL*	SL*	SL*	SL*	SL*	SL*	SL*	SL*	SL*	SL*	SL*	SL*
800 Stud Depth	Wall Height (ft)	9'	SLD	SLD	SLD	SLD	SLD	SLD	SLD	SLD	SLD	SLD	SLD	SLD	SLD	SLD	SLD	SLD	
		10'	SLD	SLD	SLD	SLD	SLD	SLD	SLD	SLD	SLD	SLD	SLD	SLD	SLD	SLD	SLD	SLD	
		12'	SLD	SLD	SLD	SLD	SLD	SLD	SLD	SLD	SLD	SLD	SLD	SLD	SLD	SLD	SLD	SLD	
		15'	SLD	SLD	SLD	SLD	SLD	SLD	SLD	SLD	SLD	SL	SLD	SL	SLD	SLD	SLD	SL	
		18'	SLD	SLD	SLD	SL	SLD	SL	SL	SL	SLD	SL	SL	SL	SLD	SL	SL	SL	
		21'	SLD	SL	SL	SL*	SL	SL	SL	SL*	SL	SL	SL*	SL*	SL	SL	SL*	SL*	
		24'	SL	SL	SL*	SL*	SL	SL*	SL*	SL*	SL	SL*	SL*	SL*	SL	SL*	SL*	SL*	

Table Notes:

- SLD considered for use on 43 mil or thinner sections
- A load factor of 0.7 is used for deflection determination
- SL\* means a single standard stud will not work. A wider flange wall stud (2" or 2.5" flange) is needed
- All connections can be made with use of 2 screws



UL2079 & UL®-Classified  
WR Grace shaft wall  
assembly HW-D-0401.

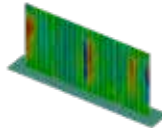

VertiClip SLD Series  
Blast and Seismic Design Data  
www.steelnetwork.com



VertiClip SLD600  
ICC-ESR-2049  
www.icc-es.org



Meets criteria for New  
York MEA 326-06-M

\*\* For more information or to review a copy of each of these reports, please visit our website at <http://www.steelnetwork.com/light-steel-framing-design-resources>

# VertiClip® SL

Exterior Head of Wall

### Material Composition

ASTM A1003/A1003M Structural Grade 50 (340) Type H, ST50H (ST340H): 50ksi (340MPa) minimum yield strength, 65ksi (450MPa) minimum tensile strength, 68mil minimum thickness (14 gauge, 0.0713" design thickness) with ASTM A653/A653M G90 (Z275) hot dipped galvanized coating.

The attachment of VertiClip SL to the primary structure may be made with PAFs, screw/bolt anchors or weld and is dependent upon the base material (steel or concrete) and the design configuration.

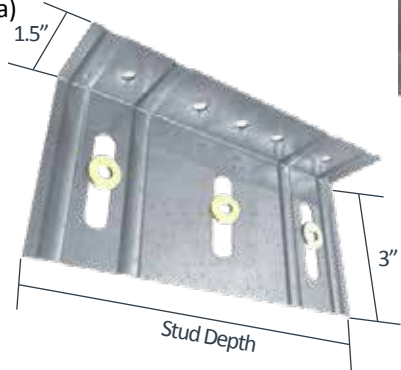

US Patents #5,467,566 & #5,906,080

### VertiClip SL Allowable (Unfactored) Loads\*

VertiClip® SL, Recommended Allowable Load (lbs): F1										
Screw Patterns with #12 Screws	F1- Load Direction									
	SL362	SL400	SL600		SL800		SL1000		SL1200	
	w/2 #12 screws	w/2 #12 screws	w/2 #12 screws	w/3 #12 screws	w/2 #12 screws	w/3 #12 screws	w/2 #12 screws	w/3 #12 screws	w/2 #12 screws	w/3 #12 screws
33mil (20ga), 33ksi Stud	190	190	190	285	190	285	190	285	190	285
33mil (20ga), 50ksi Stud	248	199	276	368	276	362	276	414	276	382
43mil (18ga), 33ksi Stud	248	199	248	368	248	362	248	372	248	372
43mil (18ga), 50ksi Stud	248	199	358	368	358	362	358	415	358	382
54mil (16ga), 33ksi Stud	248	199	312	368	312	362	312	415	312	382
54mil (16ga), 50ksi Stud	248	199	368	368	362	362	415	415	382	382
68mil (14ga), 50ksi Stud	248	199	368	368	362	362	415	415	382	382
97mil (12ga), 50ksi Stud	248	199	368	368	362	362	415	415	382	382
<b>Maximum Allowable Clip Load</b>	<b>248</b>	<b>199</b>	<b>368</b>		<b>362</b>		<b>415</b>		<b>382</b>	

VertiClip® SL, Recommended Allowable Load (lbs): F2										
Screw Patterns with #12 Screws	F2- Load Direction									
	SL362	SL400	SL600		SL800		SL1000		SL1200	
	w/2 #12 screws	w/2 #12 screws	w/2 #12 screws	w/3 #12 screws	w/2 #12 screws	w/3 #12 screws	w/2 #12 screws	w/3 #12 screws	w/2 #12 screws	w/3 #12 screws
33mil (20ga), 33ksi Stud	376	376	376	564	376	564	376	564	376	564
33mil (20ga), 50ksi Stud	544	544	544	816	544	816	544	816	544	816
43mil (18ga), 33ksi Stud	560	560	560	840	560	840	560	840	560	840
43mil (18ga), 50ksi Stud	790	810	810	1,215	810	1,215	810	1,215	810	1,215
54mil (16ga), 33ksi Stud	790	788	788	1,182	788	1,182	788	1,182	788	1,182
54mil (16ga), 50ksi Stud	790	1,136	1,138	1,680	1,138	1,707	1,138	1,577	1,138	1,707
68mil (14ga), 50ksi Stud	790	1,136	1,434	1,680	1,434	1,870	1,434	1,577	1,434	1,791
97mil (12ga), 50ksi Stud	790	1,136	1,434	1,680	1,434	1,870	1,434	1,577	1,434	1,791
<b>Maximum Allowable Clip Load</b>	<b>790</b>	<b>1,136</b>	<b>1,680</b>		<b>1,870</b>		<b>1,577</b>		<b>1,791</b>	

### Notes:

1. VertiClip SL is designed to support horizontal loads, and should not be used in axial load-bearing walls.
2. Allowable loads have not been increased for wind, seismic, or other factors.
3. Strengthening ribs are present in 3-5/8" and 6" sizes.
4. #12 screws are provided with each step bushing for attachment to the stud web.
5. Guide holes for attachment to structure are 0.141" diameter for SL362/400 and SL600. Guideholes are not standard for other clip sizes.
6. Fasten within 3/4" of the angle heel (centerline of the 1-1/2" leg) to minimize eccentric load transfer.
7. Total vertical deflection of up to 1-1/2" (3/4" up and 3/4" down). Deflection requirements greater than 3/4" (up and down) are available.
8. Allowable load tables incorporate eccentric loading of fasteners. Values with welded connection may increase.
9. For LRFD strengths contact TSN technical services.

### Load Direction

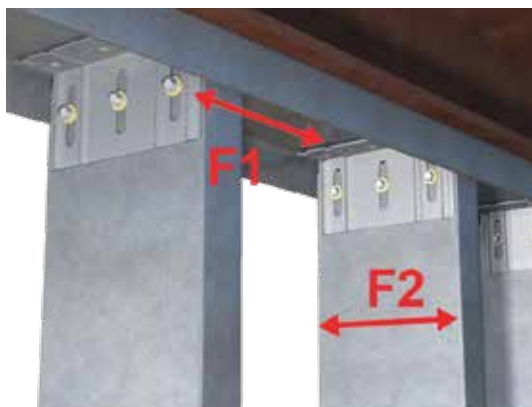

### Nomenclature

VertiClip SL is designated by type (SL), followed by stud depth in inches multiplied by 100.

**Example:** 6" stud

**Designate:** VertiClip® SL600



VertiClip SL362, SL600 & SL800  
ICC-ESR-2049  
[www.icc-es.org](http://www.icc-es.org)

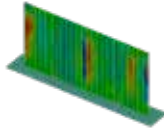

VertiClip SL Series  
Blast and Seismic Design Data  
[www.steelnetwork.com](http://www.steelnetwork.com)

**\*\* For more information or to review a copy of each of these reports, please visit our website at <http://www.steelnetwork.com/light-steel-framing-design-resources>**

# VertiClip® SLD w/ 3" Slots

Interior Head of Wall

The Steel Network, Inc.

www.steelnetwork.com

1-888-474-4876



## Material Composition

ASTM A1003/A1003M Structural Grade 50 (340) Type H, ST50H (ST340H): 50ksi (340MPa) minimum yield strength, 65ksi (450MPa) minimum tensile strength, 33mil minimum thickness (20 gauge, 0.0346" design thickness) with ASTM A653/A653M G60 (Z180) hot dipped galvanized coating.

The attachment of VertiClip SLD w/ 3" slots to the primary structure may be made with PAFs or screw/bolt anchors and is dependent up the base material (steel or concrete) and the design configuration.

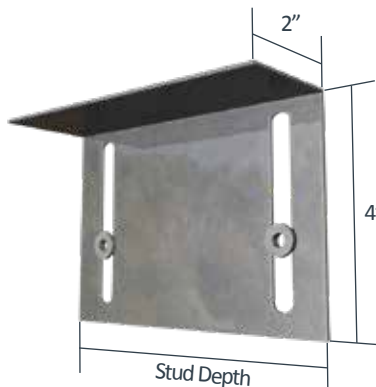

US Patents #5,467,566 & #5,906,080

## VertiClip SLD w/ 3" Deflection Allowable (Unfactored) Loads<sup>1</sup>

VertiClip® SLD w/ 3" Deflection, Recommended Allowable Load (lbs): F2			
	F2 -Load Direction		
	SLD362, s3lg,b2d	SLD600, s3lg,b2d	SLD800, s3lg,b2d
Screw Patterns with #8 Screws	w/ 2 #8 Screws	w/ 2 #8 Screws	w/ 2 #8 Screws
18mil (25ga), 33ksi Stud	132	132	132
27mil (22ga), 33ksi Stud	185	242	242
30mil (20ga-Drywall), 33ksi Stud	185	242	251
33mil (20ga-Structural), 33ksi Stud	185	242	251
33mil (20ga), 50ksi Stud	185	242	251
43mil (18ga), 33ksi Stud	185	242	251
43mil (18ga), 50ksi Stud	185	242	251
54mil (16ga), 33ksi Stud	185	242	251
54mil (16ga), 50ksi Stud	185	242	251
<b>Maximum Allowable Clip Load</b>	<b>185</b>	<b>242</b>	<b>251</b>

## Notes:

1. VertiClip SLD s3lg, b2d is designed to support horizontal loads, and should not be used in axial load-bearing walls.
2. Allowable loads have not been increased for wind, seismic, or other factors.
3. Meets IBC criteria for light steel framing. Factor of Safety calculated according to ICC-ES AC261 and Chapter K of AISI S100.
4. Tests performed with with bushings centered in the 3" slots.
5. The standard bushing placement is 2" from the top of the slot an allows the structure to settle ½" prior to typical service.
6. Total vertical deflection of up to 3" (2" up and 1" down).
7. #8 screws are provided with each step bushing for attachment to the stud web.
8. Fasten within ¼" of the angle heel (centerline of the 1 ½" leg) to minimize eccentric load transfer.
9. For LRFD strengths contact TSN technical services.

## Load Direction



## Nomenclature

VertiClip SLD with 3" deflection is is designated by type (SLD), followed by stud depth in inches multiplied by 100, slot length (s "length in inches" lg), and bushing placement (b "distance from top slot in inches" d).

**Example:** 6" deep stud, 3" slot, bushings 2" down from top of slot

**Designate:** VertiClip® SLD600,s3lg,b2d

# VertiClip® SL w/ 3" Slots

Exterior Head of Wall

The Steel Network, Inc.

www.steelnetwork.com

1-888-474-4876



### Material Composition

ASTM A1003/A1003M Structural Grade 50 (340) Type H, ST50H (ST340H): 50ksi (340MPa) minimum yield strength, 65ksi (450MPa) minimum tensile strength, 68mil minimum thickness (14 gauge, 0.0713" design thickness) with ASTM A653/A653M G90 (Z275) hot dipped galvanized coating.

The attachment of VertiClip SL w/ 3" slots to the primary structure may be made with PAFs, screw/bolt anchors or weld and is dependent up the base material (steel or concrete) and the design configuration.

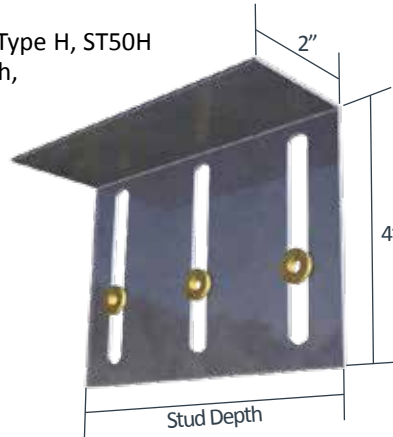

US Patents #5,467,566 & #5,906,080

### VertiClip SL w/ 3" Deflection Allowable (Unfactored) Loads<sup>1</sup>

VertiClip® SL w/ 3" Deflection, Recommended Allowable Load (lbs): F1 & F2							
	F1 Load Direction			F2 Load Direction			
	SL600, s3lg,b2d		SL362, s3lg,b2d	SL600, s3lg,b2d		SL800, s3lg,b2d	
Screw Patterns with #12 Screws	w/2 #12 Screws	w/3 #12 Screws	w/2 #12 Screws	w/2 #12 Screws	w/3 #12 Screws	w/2 #12 Screws	w/3 #12 Screws
33mil (20ga), 33ksi Stud	190	277	376	376	564	376	564
33mil (20ga), 50ksi Stud	276	277	544	544	816	544	816
43mil (18ga), 33ksi Stud	248	277	560	560	840	560	840
43mil (18ga), 50ksi Stud	277	277	617	810	1,215	810	1,215
54mil (16ga), 33ksi Stud	277	277	617	788	1,182	788	1,182
54mil (16ga), 50ksi Stud	277	277	617	1,138	1,571	1,138	1,707
68mil (14ga), 50ksi Stud	277	277	617	1,434	1,571	1,434	1,915
97mil (12ga), 50ksi Stud	277	277	617	1,434	1,571	1,434	1,915
<b>Max Allowable Clip Load</b>	<b>277</b>		<b>617</b>	<b>1,571</b>		<b>1,915</b>	

### Notes:

1. VertiClip SL s3lg, b2d is designed to support horizontal loads, and should not be used in axial load-bearing walls.
2. Allowable loads have not been increased for wind, seismic, or other factors.
3. Meets IBC criteria for light steel framing. Factor of Safety calculated according to ICC-ES AC261 and Chapter K of AISI S100.
4. Tests performed with with bushings centered in the 3" slots.
5. The standard bushing placement is 2" from the top of the slot an allows the structure to settle ½" prior to typical service.
6. Total vertical deflection of up to 3" (2" up and 1" down).
7. #12 screws are provided with each step bushing for attachment to the stud web.
8. Fasten within ¼" of the angle heel (centerline of the 1 ½" leg) to minimize eccentric load transfer.
9. For LRFD strengths contact TSN technical services.

### Load Direction



### Nomenclature

VertiClip SL with 3" deflection is is designated by type (SL), followed by stud depth in inches multiplied by 100, slot length (s "length in inches" lg), and bushing placement (b "distance from top slot in inches" d).

**Example:** 6" deep stud, 3" slot, bushings 2" down from top of slot

**Designate:** VertiClip® SL600,s3lg,b2d

# VertiClip® SLS

Bypass Structure

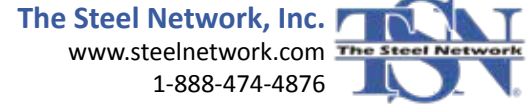

### Material Composition

ASTM A1003/A1003M Structural Grade 50 (340) Type H, ST50H (ST340H): 50ksi (340 MPa) minimum yield strength, 65ksi (450 MPa) minimum tensile strength, 68mil minimum thickness (14 gauge, 0.0713" design thickness) with ASTM A653/A653M G90 (Z275) hot dipped galvanized coating.

The attachment of VertiClip SLS to the primary structure may be made with PAFs, screw/bolt anchors or weld and is dependent upon the base material (steel or concrete) and the design configuration.



US Patents #5,467,566 & #5,906,080

### VertiClip SLS Allowable (Unfactored) Loads<sup>1</sup>

VertiClip® SLS, Recommended Allowable Load (lbs): F1											
Screw Patterns with #12 Screws	SLS362/400-9, -12	SLS600-12		SLS600-15, -18, -20		SLS600-24		SLS800-12		SLS800-15, 18, -20	
	w/2 #12 screws	w/2 #12 screws	w/3 #12 screws	w/2 #12 screws	w/3 #12 screws	w/2 #12 screws	w/3 #12 screws	w/2 #12 screws	w/3 #12 screws	w/2 #12 screws	w/3 #12 screws
33mil (20ga), 33ksi Stud	95	95	95	95	95	95	95	95	95	95	95
33mil (20ga), 50ksi Stud	124	138	138	130	130	100	100	138	138	125	125
43mil (18ga), 33ksi Stud	124	124	124	124	124	100	100	124	124	124	124
43mil (18ga), 50ksi Stud	124	164	165	130	130	100	100	141	141	125	125
54mil (16ga), 33ksi Stud	124	156	156	130	130	100	100	141	141	125	125
54mil (16ga), 50ksi Stud	124	164	164	130	130	100	100	141	141	125	125
68mil (14ga), 50ksi Stud	124	164	164	130	130	100	100	141	141	125	125
97mil (12ga), 50ksi Stud	124	164	164	130	130	100	100	141	141	125	125
<b>Max Allowable Clip Load</b>	<b>124</b>	<b>164</b>		<b>130</b>		<b>100</b>		<b>141</b>		<b>125</b>	

VertiClip® SLS, Recommended Allowable Load (lbs): F2											
Screw Patterns with #12 Screws	SLS362/400-9, -12	SLS600-12		SLS600-15, -18, -20		SLS600-24		SLS800-12		SLS800-15, 18, -20	
	w/2 #12 screws	w/2 #12 screws	w/3 #12 screws	w/2 #12 screws	w/3 #12 screws	w/2 #12 screws	w/3 #12 screws	w/2 #12 screws	w/3 #12 screws	w/2 #12 screws	w/3 #12 screws
33mil (20ga), 33ksi Stud	376	376	564	376	564	376	564	376	564	376	564
33mil (20ga), 50ksi Stud	544	544	816	544	816	544	816	544	816	544	816
43mil (18ga), 33ksi Stud	560	560	840	560	840	560	840	560	840	560	840
43mil (18ga), 50ksi Stud	810	810	1,215	810	1,215	810	1,215	810	1,215	810	1,215
54mil (16ga), 33ksi Stud	788	788	1,182	788	1,182	788	1,182	788	1,182	788	1,182
54mil (16ga), 50ksi Stud	1,138	1,138	1,707	1,138	1,707	1,138	1,707	1,138	1,707	1,138	1,707
68mil (14ga), 50ksi Stud	1,245	1,434	2,070	1,434	2,122	1,434	1,896	1,434	1,816	1,434	1,816
97mil (12ga), 50ksi Stud	1,245	1,434	2,070	1,434	2,122	1,434	1,896	1,434	1,816	1,434	1,816
<b>Max Allowable Clip Load</b>	<b>1,245</b>	<b>2,070</b>		<b>2,122</b>		<b>1,896</b>		<b>1,816</b>		<b>1,816</b>	

### Notes:

1. VertiClip SLS is designed to support horizontal loads, and should not be used in axial load-bearing walls.
2. Allowable loads have not been increased for wind, seismic, or other factors.
3. Return lip added for clips longer than 20".
4. #12 screws are provided with each step bushing for attachment to the stud web.
5. Minimum 3" of SLS required for attachment to steel structure and minimum 5-1/2" for attachment to concrete structure.
6. Fasten within 3/4" of the angle heel (centerline of the 1-1/2" leg) to minimize eccentric load transfer.
7. Total vertical deflection of up to 1-1/2" (3/4" up and 3/4" down). Deflection requirements greater than 3/4" (up and down) are available.
8. Allowable load tables incorporate eccentric loading of fasteners. Values with welded connection may increase.
9. For LRFD strengths contact TSN technical services.

### Load Direction



**Nomenclature**

VertiClip SLS is designated by stud depth and clip length required. Clip length includes a minimum of 3" for steel (5.5" for concrete) of clip material for attachment to structure added to stud depth, plus the distance of the stud from the structure.

**Example:** 6" stud, 6" tolerance, 3" to structure

**Designate:** VertiClip® SLS600-15

\* Use of strengthening ribs and return bends varies with each clip.

**Example Details**



Return lip added for clips longer than 20" (up to 36")



VertiClip SLS at jamb (studs facing each other).



VertiClip SLS600-12  
 ICC-ESR-2049  
 www.icc-es.org

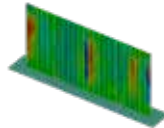

VertiClip SLS Series  
 Blast and Seismic Design Data  
 www.steelnetwork.com

\*\* For more information or to review a copy of each of these reports, please visit our website at <http://www.steelnetwork.com/light-steel-framing-design-resources>

# VertiClip® SLB

Bypass Slab



## Material Composition

ASTM A1003/A1003M Structural Grade 50 (340) Type H, ST50H (ST340H): 50ksi (340MPa) minimum yield strength, 65ksi (450MPa) minimum tensile strength, 68mil minimum thickness (14 gauge, 0.0713" design thickness) with ASTM A653/A653M G90 (Z275) hot dipped galvanized coating.

The attachment of VertiClip SLB to the primary structure may be made with PAFs, screw/bolt anchors or weld and is dependent upon the base material (steel or concrete) and the design configuration.

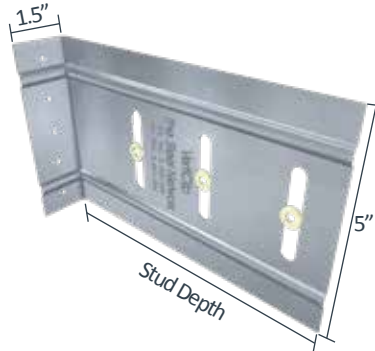

US Patents #5,467,566 & #5,906,080

## VertiClip SLB Allowable (Unfactored) Loads<sup>1</sup>

VertiClip® SLB, Recommended Allowable Load (lbs): F1 & F2										
Screw Patterns with #12 Screws	F1 Load Direction					F2 Load Direction				
	SLB250 & SLB362/400		SLB600		SLB800	SLB250 & SLB362/400		SLB600 & SLB800		SLBxxx-10, SLBxxx-12, SLB1000 & SLB1200
	w/2 #12 Screws	w/2 #12 Screws	w/3 #12 Screws	w/2 #12 Screws	w/3 #12 Screws	w/2 #12 Screws	w/2 #12 Screws	w/3 #12 Screws	w/2 #12 Screws	w/3 #12 Screws
33mil (20ga), 33ksi Stud	95	95	95	95	95	376	376	564	376	564
33mil (20ga), 50ksi Stud	138	138	138	118	118	544	544	816	544	816
43mil (18ga), 33ksi Stud	124	124	124	118	118	560	560	840	560	840
43mil (18ga), 50ksi Stud	179	179	179	118	118	810	810	1,215	810	933
54mil (16ga), 33ksi Stud	156	156	156	118	118	788	788	1,182	788	933
54mil (16ga), 50ksi Stud	225	225	225	118	118	1,138	1,138	1,600	933	933
68mil (14ga), 50ksi Stud	226	226	226	118	118	1,434	1,434	1,600	933	933
97mil (12ga), 50ksi Stud	226	226	226	118	118	1,434	1,434	1,600	933	933
<b>Max Allowable Clip Load</b>	<b>226</b>	<b>226</b>	<b>226</b>	<b>118</b>	<b>118</b>	<b>1,600</b>	<b>1,600</b>	<b>1,600</b>	<b>933</b>	<b>933</b>

## Notes:

1. VertiClip SLB is designed to support horizontal loads, and should not be used in axial load-bearing walls.
2. Allowable loads have not been increased for wind, seismic, or other factors.
3. Use of strengthening ribs and return bends vary with each clip.
4. #12 screws are provided with each step bushing for attachment to the stud web. Load requirements do not always justify the use of a third screw.
5. Guide holes for attachment to structure are 0.172" diameter for SLB250, SLB362/400, SLBxxx-10, SLBxxx-12, SLB1000, and SLB1200. Guideholes are 0.141" diameter for SLB600 and SLB800.
6. Fasten within 3/4" of the angle heel (centerline of the 1-1/2" leg) to minimize eccentric load transfer.
7. Total vertical deflection of up to 2" (1" up and 1" down). Deflection requirements greater than 1" (up and down) are available.
8. Allowable load tables incorporate eccentric loading of fasteners. Values with welded connection may increase.
9. Fasteners attaching clip to structure should be installed symmetrically around the center line of the clip. The allowable load of the clip may be reduced if fasteners are not installed symmetrically.
10. Three slots are standard in 6" and higher web depths to accommodate construction tolerances. Use of a third screw and bushing is dependent upon load configuration. 250 and 362/400 sizes have only two slots and two screws.
11. For LRFD strengths contact TSN technical services.

## Load Direction



### Nomenclature

VertiClip SLB is designated by multiplying stud depth by 100.

**Example:** 6" stud.

**Designate:** VertiClip® SLB600

\* Use of strengthening ribs and return bends varies with each clip.

\*\* The VertiClip SLB600-10 and 600-12 accommodate an even greater construction tolerance of studs from structure.

The VertiClip SLB600-10 is 10" in depth and the VertiClip SLB600-12 is 12" in depth with slot spacings designed for a 6" stud

### Example Details



Standard offset of a stud from the heel of a clip should not exceed 1.0". Step bushings and screws may be installed in the middle and outer slots of SLB600 or 800 to accommodate greater building tolerances. Note that this may affect the F1 and F2 allowable load capacity and may require a row of bridging at a maximum distance of 12" of the connection to resist stud torsional effects. Call TSN Tech Support for test data and recommendations.

The VertiClip SLB600-10 and 600-12 accommodate an even greater construction tolerance of studs from structure and are now standard products. The VertiClip SLB600-10 is 10" in depth with slot spacing designed for a 6" stud, and the VertiClip SLB600-12 is 12" in depth with slot spacing designed for a 6" stud.



VertiClip SLB600  
ICC-ESR-2049  
www.icc-es.org

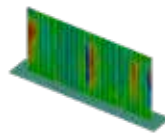

VertiClip SLB Series  
Blast and Seismic Design Data  
www.steelnetwork.com

\*\* For more information or to review a copy of each of these reports, please visit our website at <http://www.steelnetwork.com/light-steel-framing-design-resources>

# VertiClip® SLB-HD

Bypass Slab for Seismic Conditions

The Steel Network, Inc.

www.steelnetwork.com

1-888-474-4876



### Material Composition

ASTM A1003/A1003M Structural Grade 50 (340) Type H, ST50H (ST340H): 50ksi (340 MPa) minimum yield strength, 65ksi minimum tensile strength, 68mil minimum thickness (14 gauge, 0.0713" design thickness) with ASTM A653/653M G90 (Z275) hot dipped galvanized coating.

The attachment of VertiClip SLB-HD to the primary structure may be made with screw/bolt anchors or weld and is dependent up the base material (steel or concrete) and the design configuration.

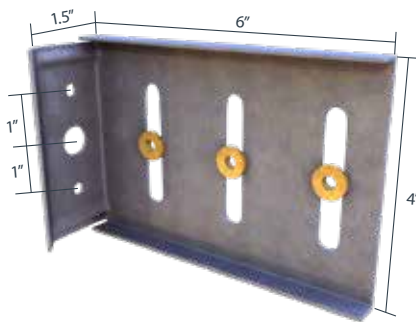

### VertiClip SLB-HD Allowable (Unfactored) Loads\*

US Patent # 5,906,080

VertiClip® SLB-HD, Recommended Allowable Load (lbs): F1 & F2						
Screw Patterns with #12 Screws	F1 - Load Direction		F2 - Load Direction with (2) 1/4" Concrete Anchors		F2 - Load Direction with (1) 1/2" Concrete Anchor	
	w/2 #12 Screws	w/3 #12 Screws	w/2 #12 Screws	w/3 #12 Screws	w/2 #12 Screws	w/3 #12 Screws
33mil (20ga), 33ksi Stud	95	95	376	564	376	564
43mil (18ga), 33ksi Stud	124	124	560	840	560	840
54mil (16ga), 33ksi Stud	156	156	788	1,182	788	1,003
54mil (16ga), 50ksi Stud	225	225	1,138	1,187	1,003	1,003
68mil (14ga), 50ksi Stud	234	234	1,187	1,187	1,003	1,003
97mil (12ga), 50ksi Stud	234	234	1,187	1,187	1,003	1,003
<b>Maximum Allowable Clip Load</b>	<b>234</b>	<b>234</b>	<b>1,187</b>		<b>1,003</b>	

### Notes:

1. VertiClip SLB600-HD is designed to support horizontal loads, and should not be used in axial load-bearing walls.
2. Allowable loads have not been increased for wind, seismic, or other factors.
3. #12 screws are provided with each step bushing for attachment to the stud web. Load requirements do not always justify the use of a third screw.
4. Guide holes for attachment to structure are 0.375" diameter for (2) 1/4" concrete screws, and 0.625" diameter for (1) 1/2" concrete anchor.
5. Fasten within 3/4" of the angle heel (centerline of the 1-1/2" leg) to minimize eccentric load transfer.
6. Total vertical deflection of up to 2" (1" up and 1" down).
7. Loads listed reflect force in a single direction. When multiple loads act on the connection, it is the responsibility of the designer to check the interaction of the forces.
8. The recommended allowable load is for the clip and attachment to the stud only. The design professional must design the attachment to the primary structure.
9. For LRFD strengths contact TSN technical services.

### Load Direction

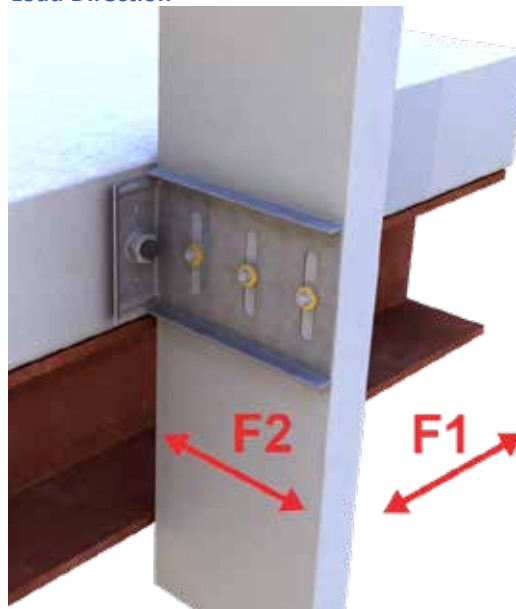

### Nomenclature

VertiClip SLB-HD is designed to be used with 6" studs and is designated VertiClip® SLB600-HD

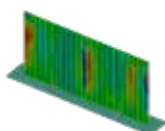

VertiClip SLB-HD Series  
Blast and Seismic Design Data  
www.steelnetwork.com

\*\* For more information or to review a copy of this report, please visit our website at <http://www.steelnetwork.com/light-steel-framing-design-resources>

# VertiClip® SLF

*Bypass Top of Slab*

## Material Composition

ASTM A1003/A1003M Structural Grade 50 (340) Type H, ST50H (ST340H): 50ksi (340 MPa) minimum yield strength, 65ksi (450 MPa) minimum tensile strength, 68mil minimum thickness (14 gauge, 0.0713" design thickness) with ASTM A653/653M G90 (Z275) hot dipped galvanized coating.

The attachment of VertiClip SLF to the primary structure may be made with PAFs, screw/bolt anchors or weld and is dependent upon the base material (steel or concrete) and the design configuration.

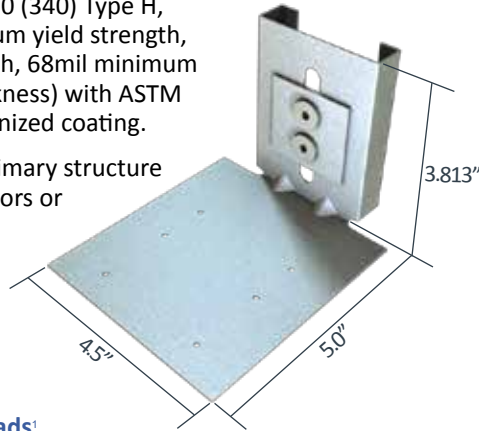

US Patent # 8,511,032

## VertiClip SLF Allowable (Unfactored) Loads<sup>1</sup>

VertiClip® SLF, Recommended Allowable Load (lbs): F2	
Screw Patterns with #12 Screws	F2 - Load Direction w/2 #12 screws
43mil (18ga), 33ksi Stud	281
43mil (18ga), 50ksi Stud	326
54mil (16ga), 33ksi Stud	401
54mil (16ga), 50ksi Stud	465
68mil (14ga), 50ksi Stud	632
97mil (12ga), 50ksi Stud	632
<b>Maximum Allowable Clip Load</b>	<b>632</b>

## Load Direction



## Notes:

1. VertiClip SLF is designed to support horizontal loads, and should not be used in axial load-bearing walls.
2. Allowable loads have not been increased for wind, seismic, or other factors.
3. #12 screws are provided with each step bushing for attachment to the stud web.
4. Total vertical deflection of up to 1-1/2" (3/4" up and 3/4" down).
5. Align rows of wall bridging so that one row of bridging falls within 12" from VertiClip SLF OR use one flat strap brace on outer flange of studs to resist torsional effects.
6. Stud web crippling should be checked. Use 3-1/2" bearing length and use the "Interior One Flange Reaction, Condition 2, scenario for web crippling calculations. If justified, using the "End One Flange Reaction, Condition 1, scenario is acceptable.
7. For LRFD strengths contact TSN technical services.

## Nomenclature

VertiClip SLF is available in one size for all stud depths with 1 5/8" flanges and is designated *VertiClip® SLF162*

\* *VertiClip SLF for use with 2" stud flanges can be made as a custom part.*

## Example Details



VertiClip SLF used with TSN's BridgeBar® & BridgeClip® installed within 12" from the clip.



VertiClip SLF used with one flat strap brace on the outer flange of studs to resist torsional effects.

# VertiClip® SLT

Structure/Slab Bypass



### Material Composition

ASTM A1003/A1003M Structural Grade 50 (340) Type H, ST50H (ST340H): 50ksi (340MPa) minimum yield strength, 65ksi (450MPa) minimum tensile strength, 97mil minimum thickness (12 gauge, 0.1017" design thickness) with ASTM A653/A653M G90 (Z275) hot dipped galvanized coating.

The attachment of VertiClip SLT to the primary structure may be made with PAFs, screw/bolt anchors or weld and is dependent up the base material (steel or concrete) and the design configuration.

### VertiClip® SLT(S)

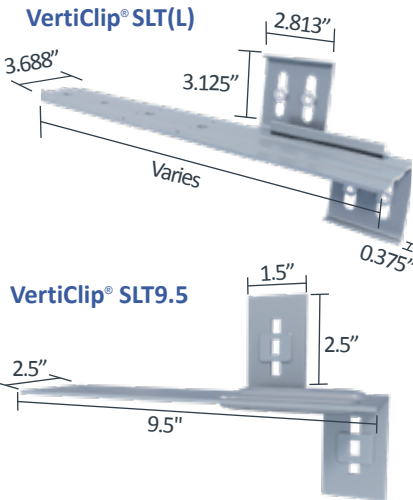
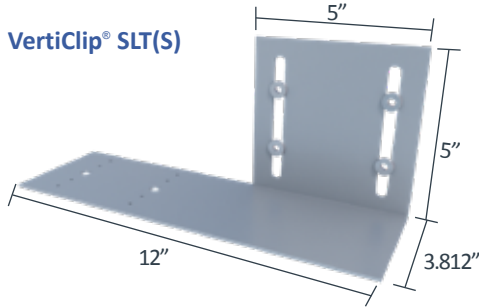

US Patents #5,467,566 & #5,906,080

### VertiClip SLT Allowable (Unfactored) Loads

VertiClip® SLT & SLT(L), Recommended Allowable Load (lbs): F1 & F2										
	F1 Load Direction			F2 Load Direction						
	SLT9.5	SLT(L)12, SLT(L)15 & SLT(L)18		SLT-9.5	SLT(L)-12		SLT(L)-15		SLT(L)-18	
Screw Patterns with #12 Screws	w/2 #12 screws	w/2 #12 screws	w/4 #12 screws	w/2 #12 screws	w/2 #12 screws	w/4 #12 screws	w/2 #12 screws	w/4 #12 screws	w/2 #12 screws	w/4 #12 screws
33mil (20ga), 33ksi Stud	190	190	380	376	376	752	376	744	376	700
33mil (20ga), 50ksi Stud	276	276	452	510	544	903	544	744	544	700
43mil (18ga), 33ksi Stud	248	248	452	510	560	903	560	744	560	700
43mil (18ga), 50ksi Stud	341	358	452	510	810	903	744	744	700	700
54mil (16ga), 33ksi Stud	312	312	452	510	788	903	744	744	700	700
54mil (16ga), 50ksi Stud	341	450	452	510	903	903	744	744	700	700
68mil (14ga), 50ksi Stud	341	452	452	510	903	903	744	744	700	700
97mil (12ga), 50ksi Stud	341	452	452	510	903	903	744	744	700	700
<b>Max Allowable Clip Load</b>	<b>341</b>	<b>452</b>	<b>510</b>	<b>903</b>	<b>744</b>	<b>700</b>	<b>744</b>	<b>700</b>	<b>700</b>	<b>700</b>

VertiClip® SLT(S), Recommended Allowable Load (lbs): F1 & F2				
Thickness Mils (ga)	F1 Load Direction		F2 Load Direction	
	Back Fasteners	Front Fasteners	Back Fasteners	Front Fasteners
	w/4 #12 screws	w/4 #12 screws	w/4 #12 screws	w/4 #12 screws
33mil (20ga), 33ksi Stud	190	190	379	379
33mil (20ga), 50ksi Stud	276	276	548	548
43mil (18ga), 33ksi Stud	248	248	564	564
43mil (18ga), 50ksi Stud	330	282	816	816
54mil (16ga), 33ksi Stud	312	282	794	794
54mil (16ga), 50ksi Stud	330	282	890	917
68mil (14ga), 50ksi Stud	330	282	890	917
97mil (12ga), 50ksi Stud	330	282	890	917
<b>Max Allowable Clip Load</b>	<b>330</b>	<b>282</b>	<b>890</b>	<b>917</b>

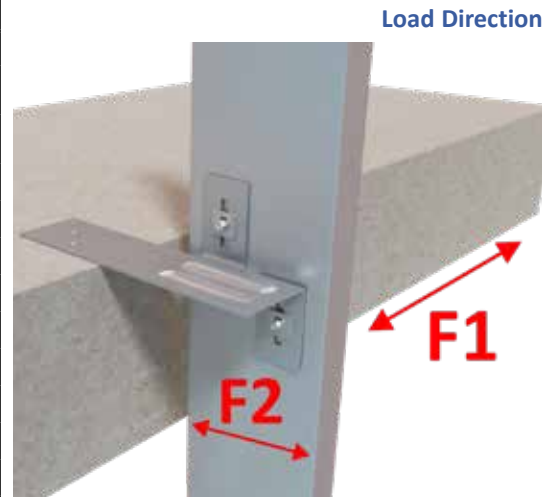

**\*\*Important notes for VertiClip SLT Allowable Load tables continued on next page.**

**Table Notes:**

1. VertiClip SLT is designed to support horizontal loads, and should not be used in axial load-bearing walls.
2. Allowable loads have not been increased for wind, seismic, or other factors.
3. #12 screws are provided with each step bushing for attachment to the stud web.
4. VertiClip SLT9.5 and SLT(S) allow up to 2" of vertical deflection (1" up and 1" down).
5. VertiClip SLT(L) allows up to 1-7/8" of vertical deflection (15/16" up and 15/16" down).
6. VertiClip SLT(S) Recommended Allowable Loads are based on (4) #12 screws at the stud attachment and either front or rear fastener attachment to the structure, respectively.
7. Torsional effects are considered on the screw group for F2 Allowable Loads. All torsion is attributed to the screws, none is attributed to the clip connection to the structure.
8. For attachment of VertiClip SLT to structure, it is recommended that fasteners to steel have a 1/2" minimum edge distance and that fasteners to concrete have a 2-1/4" minimum edge distance.
9. For LRFD strengths contact TSN technical services.

**Nomenclature**

VertiClip SLT9.5 is available in a length of 9 1/2". VertiClip SLT(S) is available in a length of 12". VertiClip SLT(L) is available in lengths of 12", 15", and 18". Determine length by adding stud + offset + 3" for steel (5.5" for concrete) and selecting the next largest size.

**Example:** 6" stud, 4" offset + 3"  
**Designate:** VertiClip® SLT(L)15

**Example Details**



**VertiClip SLT9.5 attached to the underside of wide flange beam.**

**VertiClip SLT(S) Fastener Patterns**

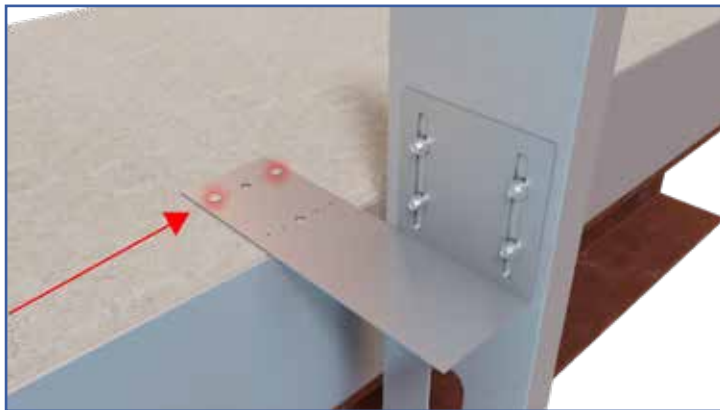

**Back Fasteners Attachment to Structure**

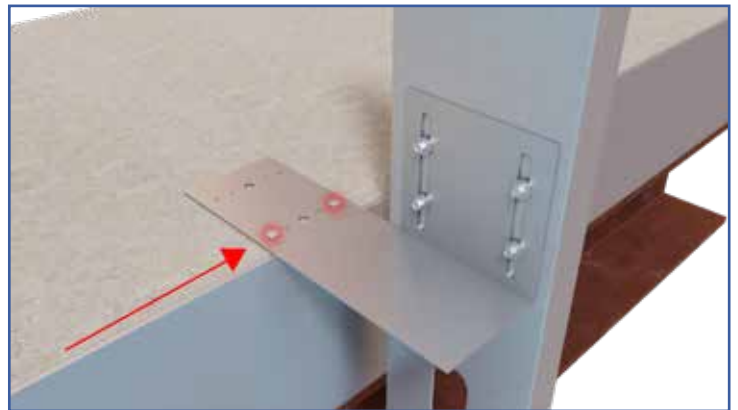

**Front Fasteners Attachment to Structure**



VertiClip SLT 9.5 & SLT(L)-18  
 ICC-ESR-2049  
 www.icc-es.org

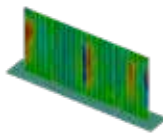

VertiClip SLT Series  
 Blast and Seismic Design Data  
 www.steelnetwork.com

\*\* For more information or to review a copy of each of these reports, please visit our website at <http://www.steelnetwork.com/light-steel-framing-design-resources>

# MasterClip® VLB

Bypass Slab

The Steel Network, Inc.

www.steelnetwork.com

1-888-474-4876



## Material Composition

ASTM A1003/A1003M Structural Grade 50 (340) Type H, ST50H (ST340H): 50ksi (340MPa) minimum yield strength, 65ksi (450MPa) minimum tensile strength, 68mil minimum thickness (14 gauge, 0.0713" design thickness) with ASTM A653/A653M G90 (Z275) hot dipped galvanized coating.

The attachment of MasterClip VLB to the primary structure may be made with PAFs, screw/bolt anchors or weld and is dependent up the base material (steel or concrete) and the design configuration.

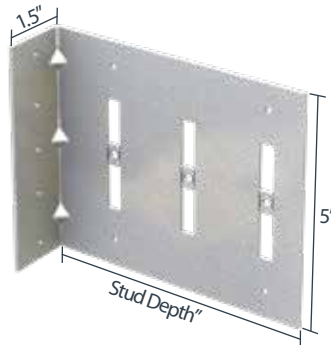

US Patents #8,181,419, #8,683,770 & #10,132,341

## MasterClip VLB Allowable Loads

Rigid Connection: F1, F2, & F3 Load Directions															
Screw Patterns with #12 Screws	F1 - Load Direction						F2 - Load Direction			F3 - Load Direction					
	VLB600			VLB800			VLB600 / VLB800			VLB600		VLB800			
	2 Screws	3 Screws	4 Screws	2 Screws	3 Screws	4 Screws	2 Screws	3 Screws	4 Screws	2 Screws	3 Screws	4 Screws	3 Screws	4 Screws	
33mil (20ga), 33ksi stud	95	190	95	182	376	444	752	250	363	502	310	440			
33mil (20ga), 50ksi stud	138	276	138	182	544	642	1,088	362	525	726	449	636			
43mil (18ga), 33ksi stud	124	248	124	182	560	661	1,120	372	540	748	462	655			
43mil (18ga), 50ksi stud	179	358	179	182	810	956	1,620	539	782	1,081	668	948			
54mil (16ga), 33ksi stud	156	312	156	182	788	930	1,576	524	760	1,052	650	922			
54mil (16ga), 50ksi stud	225	450	182	182	1,138	1,343	1,811	757	1,098	1,519	939	1,269			
68mil (14ga), 50ksi stud	284	536	182	182	1,434	1,692	1,811	954	1,384	1,792	1,183	1,269			
97mil (12ga), 50ksi stud	405	536	182	182	1,434	1,692	1,811	954	1,384	1,792	1,183	1,269			
<b>Max Allowable Clip Load</b>	<b>536</b>			<b>182</b>			<b>1,811</b>			<b>1,792</b>		<b>1,269</b>			

Vertical Deflection: F1 & F2 Load Directions						
Screw Patterns with #12 Screws	F1 - Load Direction				F2 - Load Direction	
	VLB600		VLB800		VLB600 & VLB800	
	2 Screws	3 Screws	2 Screws	3 Screws	2 Screws	3 Screws
33mil (20ga), 33ksi stud	95	95	376	564		
33mil (20ga), 50ksi stud	138	107	544	816		
43mil (18ga), 33ksi stud	124	107	560	840		
43mil (18ga), 50ksi stud	179	107	810	1,215		
54mil (16ga), 33ksi stud	156	107	788	1,182		
54mil (16ga), 50ksi stud	225	107	1,138	1,567		
68mil (14ga), 50ksi stud	259	107	1,434	1,567		
97mil (12ga), 50ksi stud	259	107	1,434	1,567		
<b>Max Allowable Clip Load</b>	<b>259</b>		<b>107</b>		<b>1,567</b>	

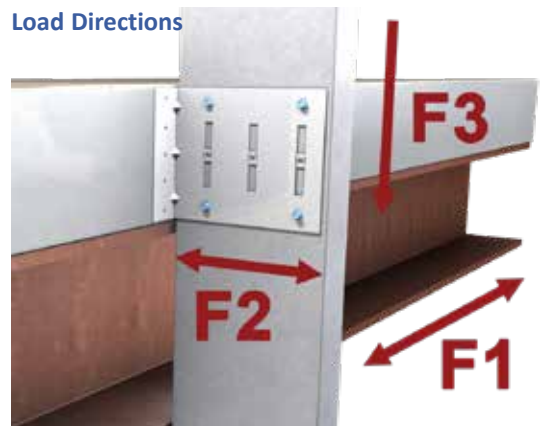

**\*\*Important notes for MasterClip VLB Allowable Load tables continued on next page.**

## Vertical Deflection Screw Patterns

## Rigid Connection Screw Patterns

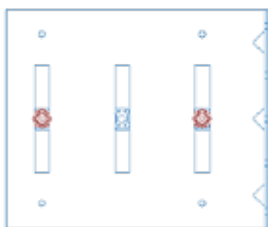

**Pattern 1**  
2 Screws

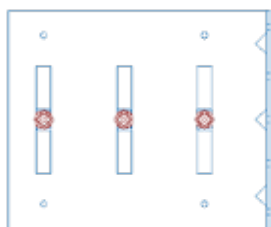

**Pattern 2**  
3 Screws

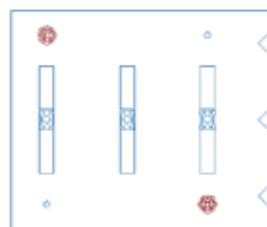

**Pattern 3**  
2 Screws

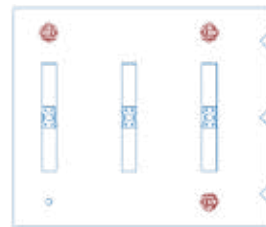

**Pattern 4**  
3 Screws

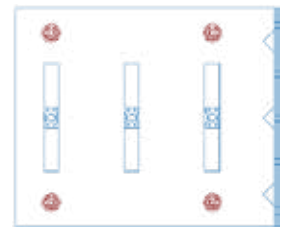

**Pattern 5**  
4 Screws

**Notes:**

1. MasterClip VLB resists in plane of wall (F1), horizontal (F2), and vertical (F3) loads when used as a rigid connector.
2. MasterClip VLB resists in plane of wall (F1) and horizontal (F2) loads when used as a deflection connector.
3. Allowable loads have not been increased for wind, seismic, or other factors.
4. Design loads consider loads on the clip and #12 screw fasteners to the stud web.
5. Three #12 screws are provided with each connector (based on number of integrated breakaway step bushings). Load requirements don't always require the use of all screws provided.
6. Three slots are standard in 6" and higher web depths to accommodate construction tolerances. Use of a 3rd screw and bushing is dependent upon load requirements.
7. Total vertical deflection up to 2" (1" up and 1" down).
8. Guide holes in the 1-1/2" leg measure 0.141" in diameter.
9. Fasten within 3/4" of the angle heel (centerline of the 1-1/2" leg) to minimize eccentric load transfer.
10. Fasteners attaching clips to structure should be installed symmetrically around the center line of the clip. The allowable load of the clip may be reduced if fasteners are not installed symmetrically.
11. Allowable load tables incorporate eccentric loading of fasteners. Values with a welded connection may increase.
12. Torsional effects are considered on the screw group for F3 allowable loads. It is assumed that half of the torsional moment is taken by the connection to the structure and half is taken by the screw connection to the stud.
13. Loads listed reflect force in a single direction. When multiple loads react on the connection, it is the responsibility of the designer to check the interaction of forces.
14. For LRFD strengths contact TSN technical services.

**Nomenclature**

MasterClip VLB is designated by type (VLB), followed by stud depth in inches multiplied by 100.

**Example:** 6" stud.

**Designate:** MasterClip® VLB600

**Example Details**

The attachment of MasterClip to the primary structure may be made with PAFs, screw/bolt anchors or welds and is dependent upon the base material (steel, concrete or CMU) and the design configuration.



MasterClip® VLB used for Vertical Deflection



MasterClip® VLB used as a Rigid Connection

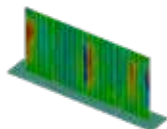

MasterClip VLB Series  
Blast and Seismic Design Data  
[www.steelnetwork.com](http://www.steelnetwork.com)

\*\* For more information or to review a copy of this report, please visit our website at <http://www.steelnetwork.com/light-steel-framing-design-resources>

# DriftClip® DSLB

Bypass Slab



## Material Composition

ASTM A1003/A1003M Structural Grade 50 (340) Type H, ST50H (ST340H): 50ksi (340MPa) minimum yield strength, 65ksi (450MPa) minimum tensile strength, 97mil minimum thickness (12 gauge, 0.1017" design thickness) with ASTM A653/A653M G90 (Z275) hot dipped galvanized coating.

The attachment of DriftClip DSLB to the primary structure may be made with PAFs, screws, or bolt anchors depending on the base material (steel or concrete) and the design configuration. The step bushings used for attachment to structure are designed for use with 1/4" maximum diameter fasteners. Designing this connection is the responsibility of the Structural Engineer of Record, and a minimum of two fasteners must be used.

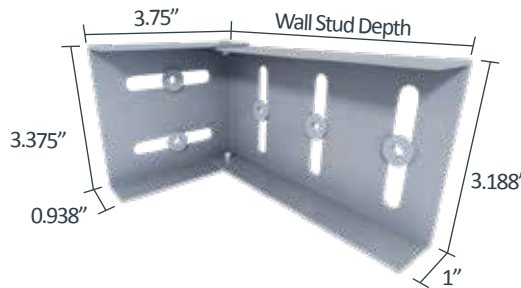

US Patent #6,612,087

## DriftClip DSLB Allowable Loads

Rigid Connection: F1, F2, & F3 Load Directions						
Screw Patterns with #12 Screws	Fastener Pattern 1			Fastener Pattern 2		
	DSLB362	DSLB600 and DSLB800		DSLB362	DSLB600 and DSLB800	
	2 Screws	2 Screws	3 Screws	2 Screws	2 Screws	3 Screws
33mil (20ga), 33ksi stud	376	376	564	377	377	565
33mil (20ga), 50ksi stud	544	544	816	544	544	572
43mil (18ga), 33ksi stud	560	560	840	561	561	572
43mil (18ga), 50ksi stud	810	810	917	572	572	572
54mil (16ga), 33ksi stud	788	788	917	572	572	572
54mil (16ga), 50ksi stud	917	917	917	572	572	572
68mil (14ga), 50ksi stud	917	917	917	572	572	572
97mil (12ga), 50ksi stud	917	917	917	572	572	572
<b>Max Allowable Clip Load</b>	<b>917</b>			<b>572</b>		

### Table Notes:

- Design loads are for attachment of DriftClip DSLB to stud only.
- Allowable loads have not been increased for wind, seismic, or other factors.
- DriftClip DSLB allows up to 2" of vertical deflection (1" up and 1" down), and 2" of lateral drift (1" left and 1" right) in plane. Deflection requirements greater than 2" of lateral drift are available.
- #12 screws are provided for each step bushing attachment to studs. Load requirements do not always require the use of a third screw.
- Attachment of structure to be engineered by others. As a design reference for the structure attachment, reference AISI S100 or screw manufacturers published data for allowable loads for screw fasteners of 1/4"-20 size with various plate thicknesses.
- One row of bridging is recommended at a maximum distance of 18" from DriftClip to resist torsional effects.
- For LRFD strengths contact TSN technical services.

### Nomenclature

DriftClip DSLB is classified by multiplying stud depth by 100.\*

**Example:** 6" stud depth

**Designate:** DriftClip® DSLB600

\* Parts with the designation "-CA" on the end of the part name includes a special bushing available to allow connection to the side of the concrete slab using two 1/4" concrete screw anchors.

\*\* If more than 2" lateral drift is required, contact TSN engineering.

## Allowable Screw Pullout

Section Thickness	Pullout 1/4" - 20 Screws*
0.0566"	261 lbs
0.0713"	328 lbs
0.1017"	468 lbs
1/8"	514 lbs
3/16"	770 lbs
1/4"	1,027 lbs
5/16"	1,284 lbs

- Limited by the allowable F2 loads shown in the table on the left
- 0.0566", 0.0713", and 0.1017" thick sections assumed to have ultimate tensile strength equal to 65 ksi.
- 1/8", 3/16", 1/4", and 5/16" thick sections assumed to have ultimate tensile strength equal to 58 ksi.
- Allowable screw pullout strengths calculated in accordance with AISI S100.

## Load Direction

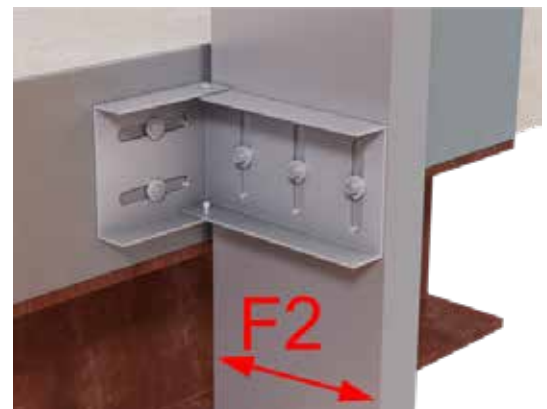

**Fastener Patterns**

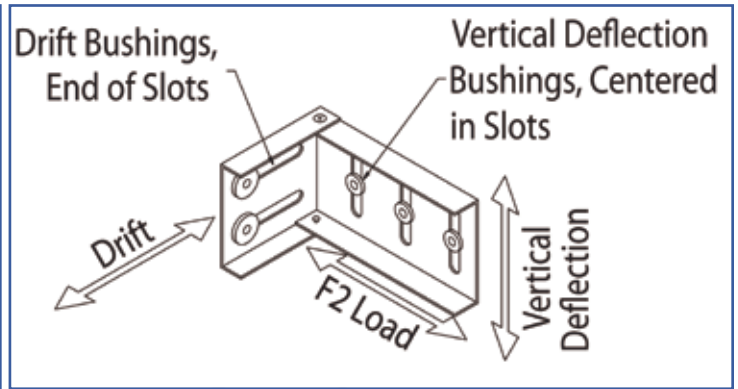
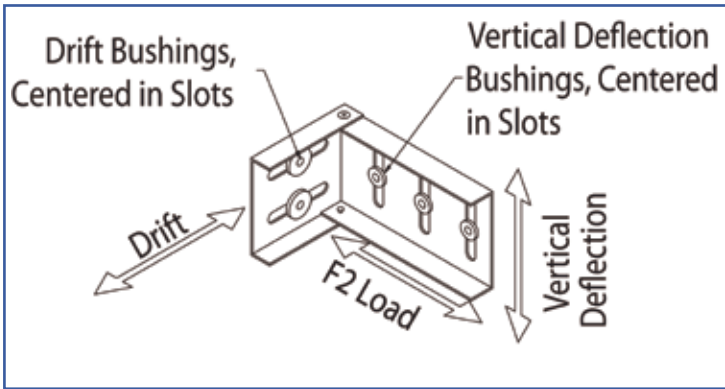

**Fastener Pattern 1** replicates a condition of out-of-plane wind or seismic force with no vertical live load deflection or in-plane drift.

**Fastener Pattern 2** replicates a condition of out-of-plane wind or seismic force with or without full vertical live load deflection and full in-plane drift.



DriftClip DSLB362/400,  
 DSLB600 & DSLB800  
 ICC-ESR-2049  
 www.icc-es.org

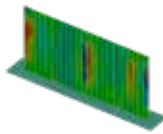

DriftClip DSLB Series  
 Blast and Seismic Design Data  
 www.steelnetwork.com

**\*\* For more information or to review a copy of each of these reports, please visit our website at <http://www.steelnetwork.com/light-steel-framing-design-resources>**

# DriftClip® DSLS

Bypass Structure

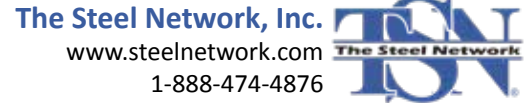

### Material Composition

ASTM A1003/A1003M Structural Grade 50 (340) Type H, ST50H (ST340H): 50ksi (340MPa) minimum yield strength, 65ksi (450MPa) minimum tensile strength, 97mil minimum thickness (12 gauge, 0.1017" design thickness) with ASTM A653/A653M G90 (Z275) hot dipped galvanized coating.

The attachment of DriftClip DSLS to the primary structure may be made with PAFs, screws, or bolt anchors depending on the base material (steel or concrete) and the design configuration. The step bushings used for attachment to structure are designed for use with ¼" maximum diameter fasteners. Designing this connection is the responsibility of the Structural Engineer of Record, and a minimum of two fasteners must be used. A minimum of 3.5" of DSLS is required for attachment to steel structure and a minimum of 6" is required for attachment to concrete structure.

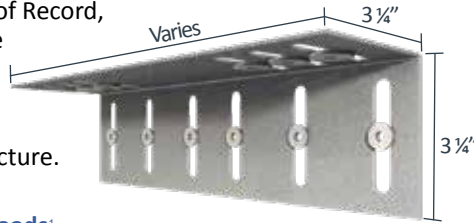

US Patent #6,612,087

### DriftClip DSLS Allowable (Unfactored) Loads<sup>1</sup>

F2 Load Direction - Fastener Pattern 1								
Screw Patterns with #12 Screws	DSLS362/400-9	DSLS362/400-12	DSLS600-10		DSLS600-12		DSLS600-15	
	w/2 Screws	w/2 Screws	w/2 Screws	w/3 #12 Screws	w/2 Screws	w/3 Screws	w/2 Screws	w/3 Screws
33mil (20ga), 33ksi Stud	376	376	376	564	376	564	376	564
33mil (20ga), 50ksi Stud	544	544	544	816	544	816	544	816
43mil (18ga), 33ksi Stud	560	560	560	840	560	840	560	840
43mil (18ga), 50ksi Stud	810	810	810	1,204	810	1,215	810	1,215
54mil (16ga), 33ksi Stud	788	788	788	1,182	788	1,182	788	1,182
54mil (16ga), 50ksi Stud	961	1,138	1,138	1,204	1,138	1,707	1,138	1,707
68mil (14ga), 50ksi Stud	961	1,237	1,204	1,204	1,434	1,862	1,434	1,903
97mil (12ga), 50ksi Stud	961	1,237	1,204	1,204	1,434	1,862	1,434	1,903
<b>Max Allowable Clip Load</b>	<b>961</b>	<b>1,237</b>	<b>1,204</b>		<b>1,862</b>		<b>1,903</b>	

DriftClip® DSLS, Recommended Allowable Load (lbs): F2 - Fastener Pattern 1								
Screw Patterns with #12 Screws	DSLS600-20		DSLS800-12		DSLS800-15		DSLS800-20	
	w/2 Screws	w/3 Screws	w/2 #12 Screws	w/3 Screws	w/2 Screws	w/3 Screws	w/2 Screws	w/3 Screws
33mil (20ga), 33ksi Stud	376	564	376	564	376	564	376	564
33mil (20ga), 50ksi Stud	544	816	544	816	544	816	544	816
43mil (18ga), 33ksi Stud	560	840	560	840	560	840	560	840
43mil (18ga), 50ksi Stud	810	1,215	810	1,164	810	1,215	810	1,215
54mil (16ga), 33ksi Stud	788	1,182	788	1,164	788	1,182	788	1,182
54mil (16ga), 50ksi Stud	1,138	1,707	1,138	1,164	1,138	1,707	1,138	1,707
68mil (14ga), 50ksi Stud	1,434	2,151	1,164	1,164	1,434	1,894	1,434	1,822
97mil (12ga), 50ksi Stud	1,434	2,151	1,164	1,164	1,434	1,894	1,434	1,822
<b>Max Allowable Clip Load</b>	<b>2,151</b>		<b>1,164</b>		<b>1,894</b>		<b>1,822</b>	

DriftClip® DSLS, Recommended Allowable Load (lbs): F2 - Fastener Pattern 2								
Screw Patterns with #12 Screws	DSLS362/400-9	DSLS362/400-12	DSLS600-10		DSLS600-12		DSLS600-15	
	w/2 Screws	w/2 Screws	w/2 Screws	w/3 Screws	w/2 Screws	w/3 Screws	w/2 Screws	w/3 Screws
33mil (20ga), 33ksi Stud	376	376	376	564	376	564	376	564
33mil (20ga), 50ksi Stud	544	544	544	816	544	816	544	816
43mil (18ga), 33ksi Stud	560	560	560	840	560	840	560	840
43mil (18ga), 50ksi Stud	810	810	810	1,018	810	1,215	810	1,215
54mil (16ga), 33ksi Stud	788	788	788	1,018	788	1,182	788	1,182
54mil (16ga), 50ksi Stud	943	1,078	1,018	1,018	1,138	1,707	1,138	1,707
68mil (14ga), 50ksi Stud	943	1,078	1,018	1,018	1,434	1,742	1,434	1,903
97mil (12ga), 50ksi Stud	943	1,078	1,018	1,018	1,434	1,742	1,434	1,903
<b>Max Allowable Clip Load</b>	<b>943</b>	<b>1,078</b>	<b>1,018</b>		<b>1,742</b>		<b>1,903</b>	

**\*\*DriftClip DSLS Allowable Load tables and important notes continued on next page.**

DriftClip® DSLS, Recommended Allowable Load (lbs): F2 - Fastener Pattern 2								
Screw Patterns with #12 Screws	DSLS600-20		DSLS800-12		DSLS800-15		DSLS800-20	
	w/2 Screws	w/3 Screws	w/2 Screws	w/3 Screws	w/2 Screws	w/3 Screws	w/2 Screws	w/3 Screws
33mil (20ga), 33ksi Stud	376	564	376	564	376	564	376	564
33mil (20ga), 50ksi Stud	544	816	544	816	544	816	544	816
43mil (18ga), 33ksi Stud	560	840	560	840	560	840	560	840
43mil (18ga), 50ksi Stud	810	1,215	810	1,158	810	1,198	810	1,215
54mil (16ga), 33ksi Stud	788	1,182	788	1,158	788	1,182	788	1,182
54mil (16ga), 50ksi Stud	1,138	1,663	1,138	1,158	1,138	1,198	1,138	1,246
68mil (14ga), 50ksi Stud	1,434	1,663	1,158	1,158	1,198	1,198	1,246	1,246
97mil (12ga), 50ksi Stud	1,434	1,663	1,158	1,158	1,198	1,198	1,246	1,246
<b>Max Allowable Clip Load</b>	<b>1,663</b>		<b>1,158</b>		<b>1,198</b>		<b>1,246</b>	

**Notes:**

1. Design loads are for attachment of DriftClip DSLS to stud only.
2. Allowable loads have not been increased for wind, seismic, or other factors.
3. DriftClip DSLS allows up to 2" of vertical deflection (1" up and 1" down), and 2" of lateral drift (1" left and 1" right) in plane. Deflection requirements greater than 2" of lateral drift are available.
4. #12 screws are provided for each step bushing attachment to studs. Load requirements do not always require the use of a third screw.
5. Attachment of structure to be engineered by others. As a design reference for the structure attachment, reference AISI S100 or screw manufacturers published data for allowable loads for screw fasteners of 1/4"-20 size with various plate thicknesses.
6. One row of bridging is recommended at a maximum distance of 18" from DriftClip to resist torsional effects.
7. Return lip added for clips longer than 20".
8. For LRFD strengths contact TSN technical services.

**Load Direction**



**Nomenclature**

DriftClip DSLS is classified by multiplying stud depth by 100, followed by length.

**Example:** 6" stud depth, 15" length

**Designate:** DriftClip® DSLS600-15

\* If more than 2" lateral drift is required, contact TSN engineering.

**Fastener Patterns**

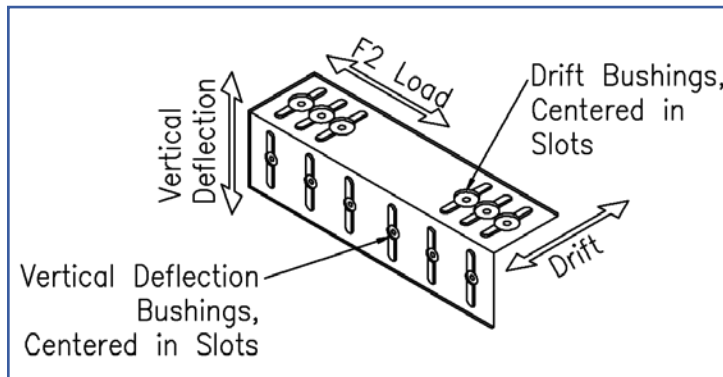

**Fastener Pattern 1** replicates a condition of out-of-plane wind or seismic force with no vertical live load deflection or in-plane drift.

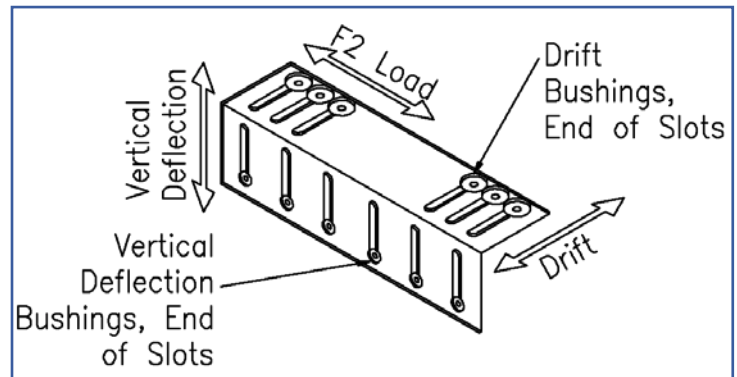

**Fastener Pattern 2** replicates a condition of out-of-plane wind or seismic force with full vertical live load deflection and full in-plane drift.

ICC  
ES  
DriftClip DSLS600-12 &  
DSLS600-15  
ICC-ESR-2049  
www.icc-es.org

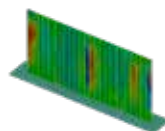

DriftClip DSLS Series  
Blast and Seismic Design Data  
www.steelnetwork.com

\*\* For more information or to review a copy of each of these reports, please visit our website at <http://www.steelnetwork.com/light-steel-framing-design-resources>

# DriftClip® DSLD

Interior Head of Wall

### Material Composition

ASTM A1003/A1003M Structural Grade 50 (340) Type H, ST50H (ST340H): 50ksi (340MPa) minimum yield strength, 65ksi (450MPa) minimum tensile strength, 33mil minimum thickness (20 gauge, 0.0346" design thickness) with ASTM A653/A653M G60 (Z180) hot dipped galvanized coating.

The attachment of DriftClip DSLD to the primary structure utilizes step bushings designed for #8 (0.164") screws. Designing this connection is the responsibility of the Structural Engineer of Record, and a minimum of two fasteners must be used.

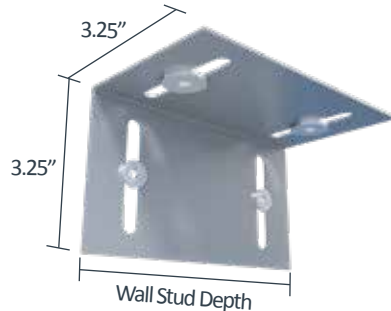

US Patent #6,612,087

### DriftClip DSLD Allowable (Unfactored) Loads<sup>1</sup>

DriftClip® DSLD, Recommended Allowable Load (lbs): F2							
Stud		Fastener Pattern 1			Fastener Pattern 2		
Thickness Mils (ga)	Yield Strength (ksi)	DSLDD362 w/2 #8 Screws	DSLDD600 w/2 #8 Screws	DSLDD800 w/2 #8 Screws	DSLDD362 w/2 #8 Screws	DSLDD600 w/2 #8 Screws	DSLDD800 w/2 #8 Screws
18 (25)	33	70	132	132	27	107	132
27 (22)	33	70	178	199	27	107	183
33 (20)	33	70	178	199	27	107	183
33 (20)	50	70	178	199	27	107	183
43 (18)	33	70	178	199	27	107	183
43 (18)	50	70	178	199	27	107	183
54 (16)	33	70	178	199	27	107	183
54 (16)	50	70	178	199	27	107	183
<b>Maximum Allowable Clip Load</b>		<b>70</b>	<b>178</b>	<b>199</b>	<b>27</b>	<b>107</b>	<b>183</b>

### Notes:

1. Design loads are for attachment of DriftClip DSLD to stud only.
2. Allowable loads have not been increased for wind, seismic, or other factors.
3. DriftClip DSLD allows up to 2" of vertical deflection (1" up and 1" down), and 2" of lateral drift (1" left and 1" right) in plane. Deflection requirements greater than 2" of lateral drift are available.
4. #8 screws are provided for each step bushing attachment to studs.
5. Attachment of structure to be engineered by others.
6. For LRFD strengths contact TSN technical services.

### Nomenclature

DriftClip DSLD is classified by multiplying stud depth by 100.

**Example:** 6" stud depth

**Designate:** DriftClip® DSLD600

### Load Direction

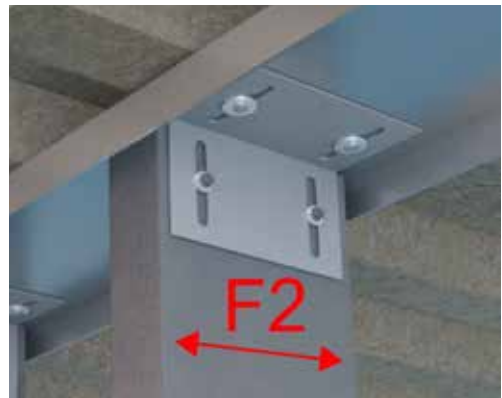

**Fastener Patterns**

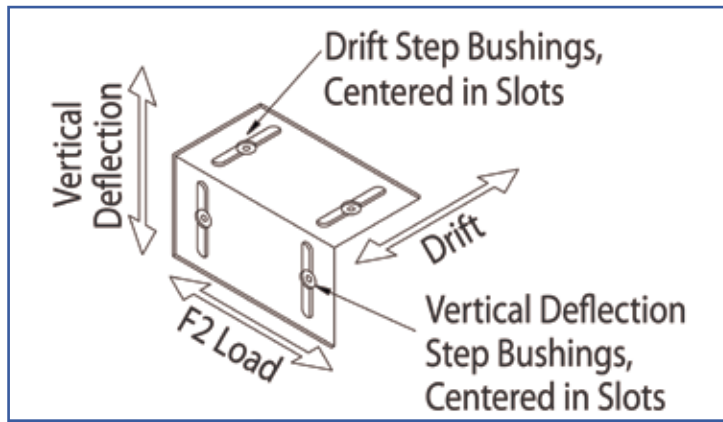

**Fastener Pattern 1** replicates a condition of out-of-plane wind or seismic force with no vertical live load deflection or in-plane drift.

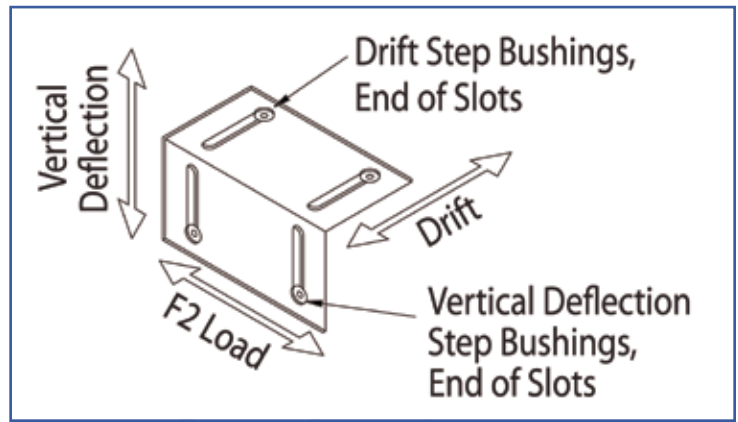

**Fastener Pattern 2** replicates a condition of out-of-plane wind or seismic force with full vertical live load deflection and full in-plane drift.



UL2079 Head of Wall Assemblies



DriftClip DSLD362/400, DSLS600 & DSLD800  
ICC-ESR-2049  
www.icc-es.org

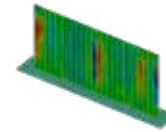

DriftClip DSLD Series  
Blast and Seismic Design Data  
www.steelnetwork.com

\*\* For more information or to review a copy of each of these reports, please visit our website at <http://www.steelnetwork.com/light-steel-framing-design-resources>

# DriftClip® DSL

Exterior Head of Wall

## Material Composition

ASTM A1003/A1003M Structural Grade 50 (340) Type H, ST50H (ST340H): 50ksi (340MPa) minimum yield strength, 65ksi (450MPa) minimum tensile strength, 97mil minimum thickness (12 gauge, 0.1017" design thickness) with ASTM A653/A653M G90 (Z275) hot dipped galvanized coating.

The attachment of DriftClip DSL to the primary structure may be made with PAFs, screws, or bolt anchors depending on the base material (steel or concrete) and the design configuration. The step bushings used for attachment to structure are designed for use with ¼" maximum diameter fasteners. Designing this connection is the responsibility of the Structural Engineer of Record, and a minimum of two fasteners must be used.

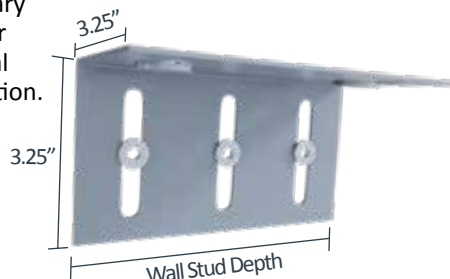

US Patent #6,612,087

## DriftClip DSL Allowable (Unfactored) Loads<sup>1</sup>

DriftClip® DSL, Recommended Allowable Load (lbs): F2												
Stud		Fastener Pattern 1					Fastener Pattern 2					
Thickness Mils (ga)	Yield Strength (ksi)	DSL362 w/2 #12 Screws	DSL600 w/2 #12 Screws	DSL600 w/3 #12 Screws	DSL800 w/2 #12 Screws	DSL800 w/3 #12 Screws	DSL362 w/2 #12 Screws	DSL600 w/2 #12 Screws	DSL600 w/3 #12 Screws	DSL800 w/2 #12 Screws	DSL800 w/3 #12 Screws	
33 (20)	33	357	376	56	376	564	129	376	418	376	564	
33 (20)	50	357	544	776	544	816	129	418	418	544	816	
43 (18)	33	357	560	776	560	840	129	418	418	560	840	
43 (18)	50	357	776	776	810	1,041	129	418	418	810	1,041	
54 (16)	33	357	776	776	788	1,041	129	418	418	788	1,041	
54 (16)	50	357	776	776	1,041	1,041	129	418	418	1,041	1,041	
68 (14)	50	357	776	776	1,041	1,041	129	418	418	1,041	1,041	
97 (12)	50	357	776	776	1,041	1,041	129	418	418	1,041	1,041	
<b>Max Allowable Clip Load</b>		<b>357</b>	<b>776</b>		<b>1,041</b>		<b>129</b>	<b>418</b>		<b>1,041</b>		

### Notes:

- Design loads are for attachment of DriftClip DSL to stud only.
- Allowable loads have not been increased for wind, seismic, or other factors.
- DriftClip DSL allows up to 2" of vertical deflection (1" up and 1" down), and 2" of lateral drift (1" left and 1" right) in plane. Deflection requirements greater than 2" of lateral drift are available.
- #12 screws are provided for each step bushing attachment to studs. Load requirements do not always require the use of a third screw.
- Attachment of structure to be engineered by others. As a design reference for the structure attachment, reference AISI S100 or screw manufacturers published data for allowable loads for screw fasteners of 1/4"-20 size with various plate thicknesses.
- One row of bridging is recommended at a maximum distance of 18" from DriftClip to resist torsional effects.
- For LRFD strengths contact TSN technical services.

### Load Direction



### Nomenclature

DriftClip DSL is classified by multiplying stud depth by 100.\*

**Example:** 6" stud depth

**Designate:** DriftClip® DSL600

\* Parts with the designation "-CA" on the end of the part name includes a special bushing available to allow connection to the side of the concrete slab using two ¼" concrete screw anchors

\*\* If more than 2" lateral drift is required, contact TSN engineering.

**Fastener Patterns**

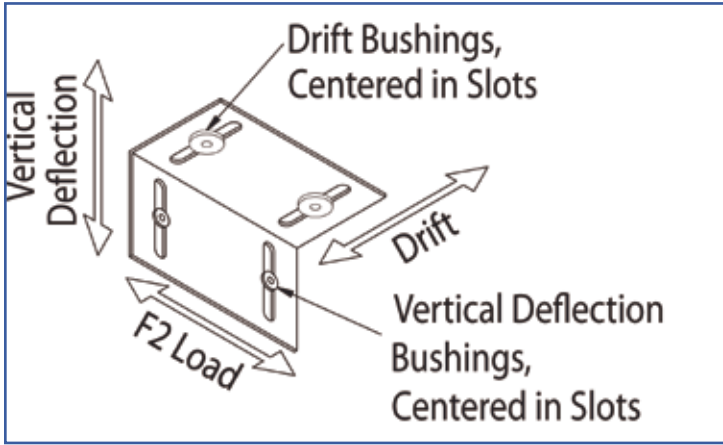

**Fastener Pattern 1** replicates a condition of out-of-plane wind or seismic force with no vertical live load deflection or in-plane drift.

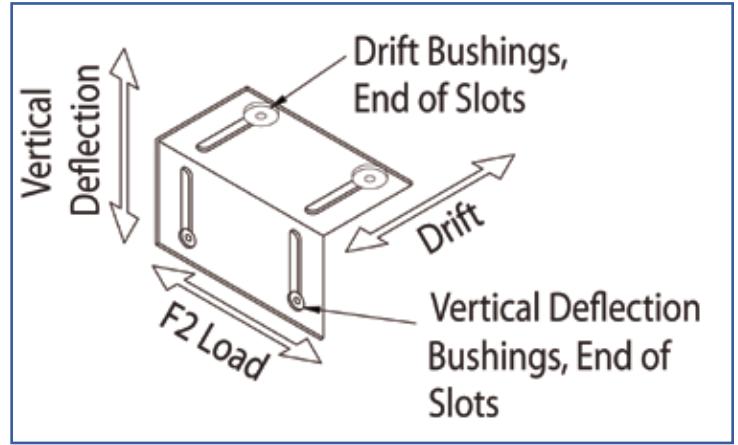

**Fastener Pattern 2** replicates a condition of out-of-plane wind or seismic force with full vertical live load deflection and full in-plane drift.



DriftClip DSL362/400,  
DSL600 & DSL800  
ICC-ESR-2049  
www.icc-es.org

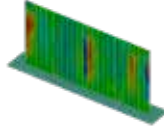

DriftClip DSL Series  
Blast and Seismic Design Data  
www.steelnetwork.com

**\*\* For more information or to review a copy of each of these reports, please visit our website at <http://www.steelnetwork.com/light-steel-framing-design-resources>**

# DriftTrak® DT w/DTSL

Exterior Head of Wall

The Steel Network, Inc.

www.steelnetwork.com

1-888-474-4876



## Material Composition

**DTSL Clip Material:** ASTM A1003/A1003M Structural Grade 50 (340) Type H, ST50H (ST340H): 50ksi (340MPa) minimum yield strength, 65ksi (450MPa) minimum tensile strength, 68mil minimum thickness (14 gauge, 0.0713" design thickness) with ASTM A653/A653M G90 (Z275) hot dipped galvanized coating.

**Track Material:** ASTM A1003/A1003M Structural Grade 50 (340) Type H, ST50H (ST340H): 50ksi (340MPa) minimum yield strength, 65ksi (450MPa) minimum tensile strength, 97mil minimum thickness (12 gauge, 0.1017" design thickness) with ASTM A653/A653M G60 (Z180) hot dipped galvanized coating.



US Patent #7,503,150

## DriftTrak DT w/ DTSL Allowable (Unfactored) Loads

DriftTrak® DT w/ DTSL, Recommended Allowable Load (lbs): F2

Stud		8" Fastener Spacing in Track to Structure (or welded on both sides)		16" Fastener Spacing in Track to Structure (or welded on both sides)	
		Fastener Pattern 1	Fastener Pattern 2	Fastener Pattern 1	Fastener Pattern 2
Thickness Mils (ga)	Yield Strength (ksi)	w/2 #12 Screws	w/2 #12 Screws	w/2 #12 Screws	w/2 #12 Screws
33 (20)	33	376	376	376	449
33 (20)	50	544	482	544	449
43 (18)	33	560	482	560	449
43 (18)	50	625	482	625	449
54 (16)	33	625	482	625	449
54 (16)	50	625	482	625	449
68 (14)	50	625	482	625	449
97 (12)	50	625	482	625	449
<b>Maximum Allowable Clip Load</b>		<b>625</b>	<b>482</b>	<b>625</b>	<b>449</b>

## Notes:

- Design loads are for attachment of DriftTrak DT w/ DTSL to stud only.
- Allowable loads have not been increased for wind, seismic, or other factors.
- Clips are manufactured to fit into DriftTrak DT. DriftTrak DT w/ DTSL allows up to 2" of vertical deflection (1" up and 1" down), and free lateral movement of the structure.
- #12 screws are provided for each step bushing attachment to studs.
- Attachment of structure to be engineered by others.
- One row of bridging is recommended at a maximum distance of 18" from DriftTrak DT w/ DTSL to resist torsional effects.
- DriftTrak DT w/ DTSL does not provide wall closure. A top track will be required for closure of the wall assembly.
- Allow a minimum of 7/8" from the structure to the top of the stud to allow for the attachment of the DriftTrak DT inside the standard track.
- For LRFD strengths contact TSN technical services.

## Nomenclature

DriftTrak® DT w/ DTSL is available in one size for all stud depths over 3 5/8".

**Example:** 6" stud depth

**Designate:** DriftTrak® DT w/ DTSL

DriftTrak DT is available in 10' and 12' lengths, and is designated: DriftTrak® DT-10' or DT-12'

\*\* A top track is required for closure of the wall assembly.

\*\*\* Clips and track sold separately.

## Load Direction



**Fastener Patterns**

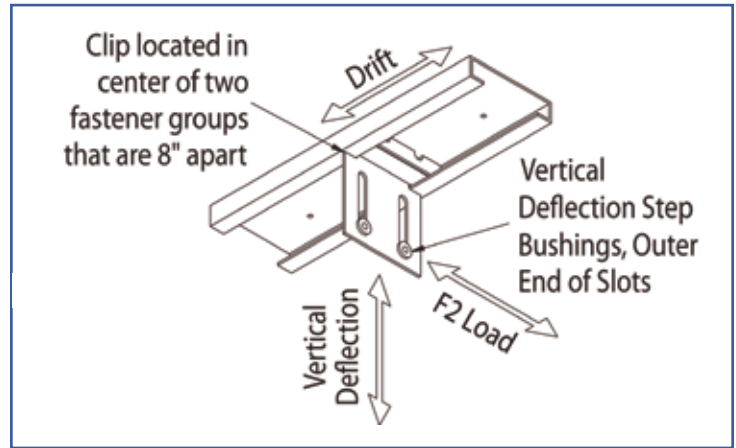
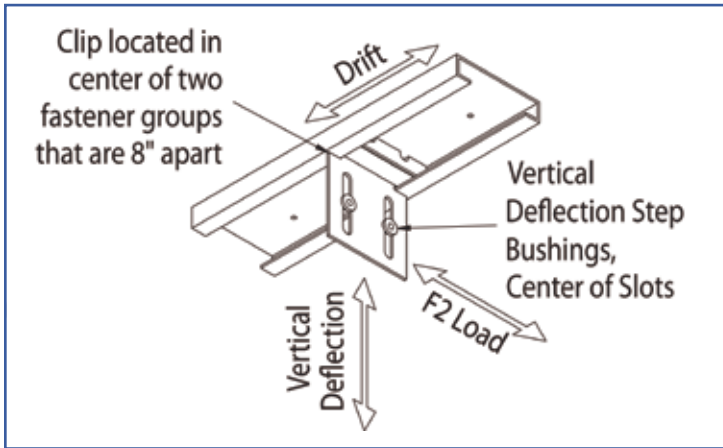

**Fastener Pattern 1** replicates a condition of out-of-plane wind or seismic force with no vertical live load deflection and full in-plane drift.

**Fastener Pattern 2** replicates a condition of out-of-plane wind or seismic force with full vertical live load deflection and full in-plane drift.



DriftTrak DT w/DTSL  
ICC-ESR-2049  
www.icc-es.org

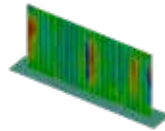

DriftTrak DT w/ DTSL Series  
Blast and Seismic Design Data  
www.steelnetwork.com

\*\* For more information or to review a copy of each of these reports, please visit our website at <http://www.steelnetwork.com/light-steel-framing-design-resources>

# DriftTrak® DT w/DTSLB

Bypass Slab

The Steel Network, Inc.

www.steelnetwork.com

1-888-474-4876



## Material Composition

**DTSLB Clip Material:** ASTM A1003/A1003M Structural Grade 50 (340) Type H, ST50H (ST340H): 50ksi (340MPa) minimum yield strength, 65ksi (450MPa) minimum tensile strength, 68mil minimum thickness (14 gauge, 0.0713" design thickness) with ASTM A653/A653M G90 (Z275) hot dipped galvanized coating.

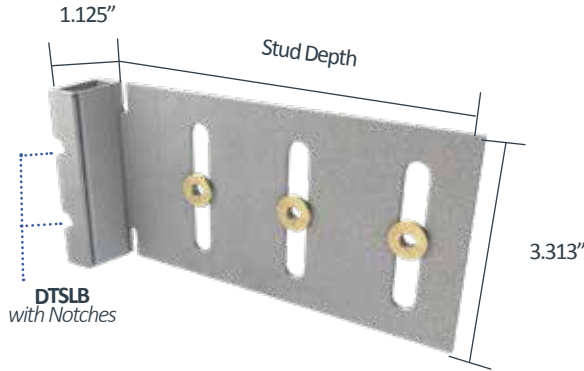

US Patent #7,503,150

## DriftTrak DT w/DTSLB Allowable (Unfactored) Loads<sup>1</sup>

DriftTrak® DT w/ DTSLB, Recommended Allowable Load (lbs): F2					
Stud		DTSLB			
		8" Fastener Spacing in Track to Structure <i>(or welded on each side)</i>		16" Fastener Spacing in Track to Structure <i>(or welded on each side)</i>	
Thickness Mils (ga)	Yield Strength (ksi)	w/2 #12 Screws	w/3 #12 Screws	w/2 #12 Screws	w/3 #12 Screws
33 (20)	33	376	564	376	564
33 (20)	50	544	808	544	753
43 (18)	33	560	808	560	753
43 (18)	50	808	808	753	753
54 (16)	33	788	808	753	753
54 (16)	50	808	808	753	753
68 (14)	50	808	808	753	753
97 (12)	50	808	808	753	753
<b>Maximum Allowable Clip Load</b>		<b>808</b>		<b>753</b>	

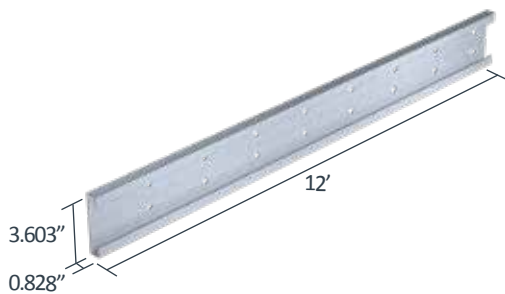

## Notes:

- Design loads are for attachment of DriftTrak DT w/ DTSLB to stud only.
- Allowable loads have not been increased for wind, seismic, or other factors.
- Clips are manufactured to fit into DriftTrak DT. DriftTrak DT w/ DTSLB allows up to 2" of vertical deflection (1" up and 1" down), and free lateral movement of the structure.
- #12 screws are provided for each step bushing attachment to studs. Load requirements don't always justify use of a third screw.
- Attachment to structure at 8" or 16" spacing to be engineered by others.
- One row of bridging is recommended at a maximum distance of 18" from DriftTrak DT w/ DTSLB to resist torsional effects.
- Notches are standard in DTSLB clips. For greater F2 load capacities, use DTSLB-HD clips without notches. Refer to allowable load tables.
- Allow a minimum of 7/8" from the structure to the inside flange of the bypassing stud to allow for track attachment.
- Total offset of stud from the edge of slab should not exceed 2" for DriftTrak DT w/ DTSLB362/400 or DTSLB600 clips.
- Total offset of stud from the edge of slab should not exceed 3-1/4" for DriftTrak DT w/ DTSLB800 clips.
- Total offset is measured from the edge of slab to the inside face of the stud.
- For LRFD strengths contact TSN technical services.

## Load Direction



**Nomenclature**

DriftTrak DT w/ DTSLB is specified by designating the track section and the clip size by multiplying the stud depth by 100.

**Example:** Track fastened at 8" or 16", 6" stud depth, with an outward load (F2) of 1,000 lbs

**Designate:** DriftTrak® DT w/ DTSLB600

**Fastener Patterns**

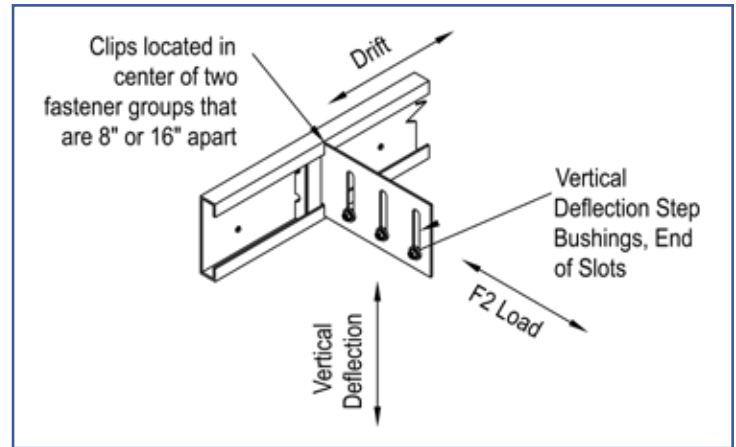
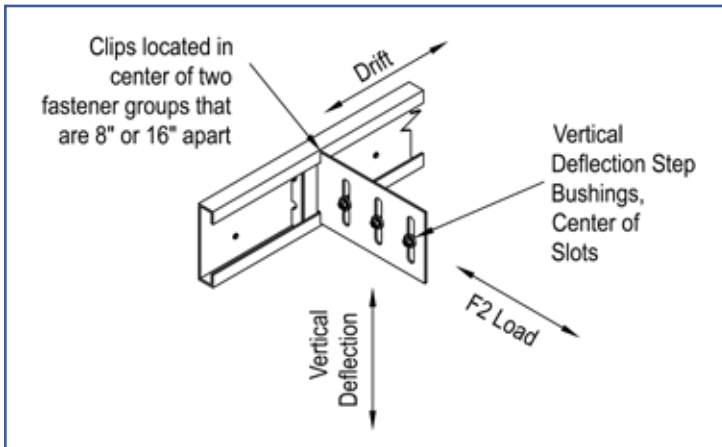

**Fastener Pattern 1** replicates a condition of out-of-plane wind or seismic force with no vertical live load deflection and full in-plane drift.

**Fastener Pattern 2** replicates a condition of out-of-plane wind or seismic force with full vertical live load deflection and full in-plane drift.

**Locking of Lateral Movement After Panel Installation**

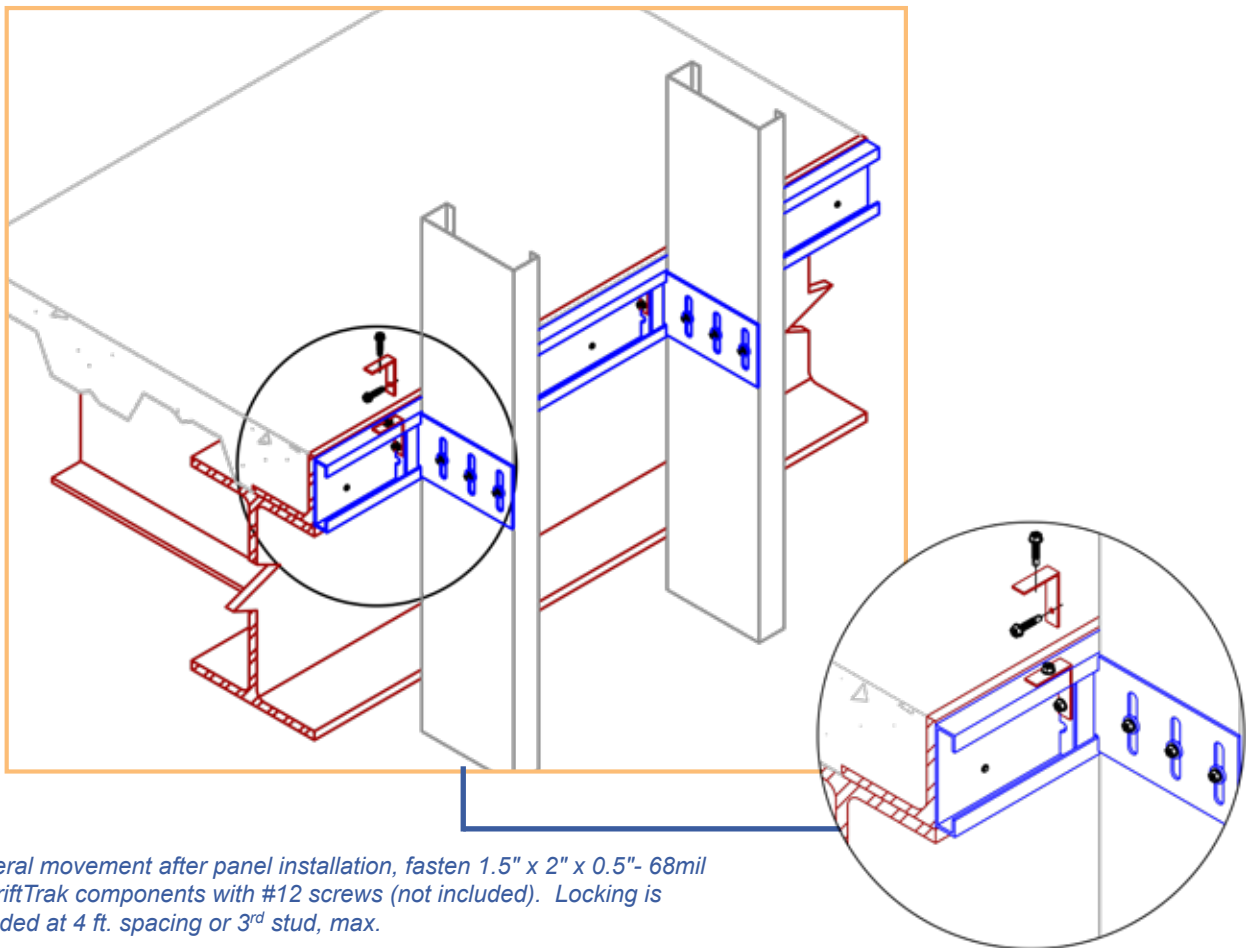

To lock lateral movement after panel installation, fasten 1.5" x 2" x 0.5"- 68mil angle to DriftTrak components with #12 screws (not included). Locking is recommended at 4 ft. spacing or 3<sup>rd</sup> stud, max.



DriftTrak DT w/ DTSLB362/400,  
DTSLB600 & DTSLB800  
ICC-ESR-2049  
www.icc-es.org

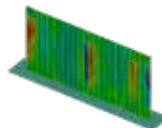

DriftTrak DT w/ DTSLB Series  
Blast and Seismic Design Data  
www.steelnetwork.com

\*\* For more information or to review a copy of each of these reports, please visit our website at <http://www.steelnetwork.com/light-steel-framing-design-resources>

# DriftTrak® DT w/DTSLB-HD

Bypass Slab

## Material Composition

**DTSLB-HD Clip and Track Material:** ASTM A1003/A1003M Structural Grade 50 (340) Type H, ST50H (ST340H): 50ksi (340MPa) minimum yield strength, 65ksi (450MPa) minimum tensile strength, 97mil minimum thickness (12 gauge, 0.1017" design thickness) with ASTM A653/A653M G60 (Z180) hot dipped galvanized coating.



US Patent #7,503,150

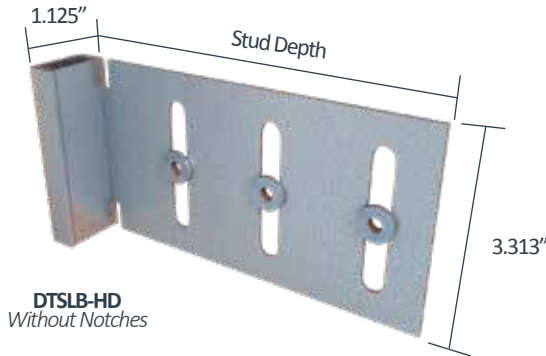

DTSLB-HD  
Without Notches

Coordinate location of clips and studs with locations of anchors.

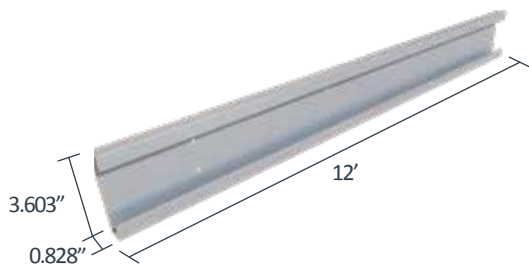

## DriftTrak DT w/ DTSLB-HD Allowable (Unfactored) Loads<sup>1</sup>

DriftTrak® DT w/ DTSLB-HD, Recommended Allowable Load (lbs): F2					
Stud		DTSLB-HD			
		8" Fastener Spacing in Track to Structure (or welded on each side)		16" Fastener Spacing in Track to Structure (or welded on each side)	
Thickness Mils (ga)	Yield Strength (ksi)	w/2 #12 Screws	w/3 #12 Screws	w/2 #12 Screws	w/3 #12 Screws
33 (20)	33	376	564	376	564
33 (20)	50	544	816	544	816
43 (18)	33	560	840	560	840
43 (18)	50	810	1,215	753	953
54 (16)	33	788	1,182	753	953
54 (16)	50	1,138	1,618	753	953
68 (14)	50	1,434	1,618	753	953
97 (12)	50	1,434	1,618	753	953
<b>Maximum Allowable Clip Load</b>		<b>1,618</b>		<b>953</b>	

### Notes:

- Design loads are for attachment of DriftTrak DT w/ DTSLB-HD to stud only.
- Allowable loads have not been increased for wind, seismic, or other factors.
- Clips are manufactured to fit into DriftTrak DT. DriftTrak DT w/ DTSLB-HD allows up to 2" of vertical deflection (1" up and 1" down), and free lateral movement of the structure.
- #12 screws are provided for each step bushing attachment to studs. Load requirements don't always justify use of a third screw.
- Attachment to structure at 8" or 16" spacing to be engineered by others.
- One row of bridging is recommended at a maximum distance of 18" from DriftTrak DT w/ DTSLB-HD to resist torsional effects.
- Allow a minimum of 7/8" from the structure to the inside flange of the bypassing stud to allow for track attachment.
- Total offset of stud from the edge of slab should not exceed 2" for DriftTrak DT w/ DTSLB362/400-HD or DTSLB600-HD clips.
- Total offset of stud from the edge of slab should not exceed 3-1/4" for DriftTrak DT w/ DTSLB800-HD clips.
- Total offset is measured from the edge of slab to the inside face of the stud.
- For LRFD strengths contact TSN technical services.

### Load Direction

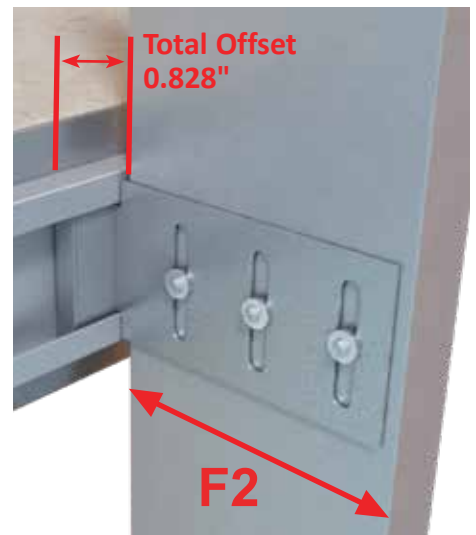

**Nomenclature**

DriftTrak DT w/ DTSLB-HD is specified by designating the track section and the clip size by multiplying the stud depth by 100.

**Example:** Track fastened at 8" or 16", 6" stud depth, with an outward load (F2) of 1,000 lbs

**Designate:** DriftTrak® DTSLB600

**Fastener Patterns**

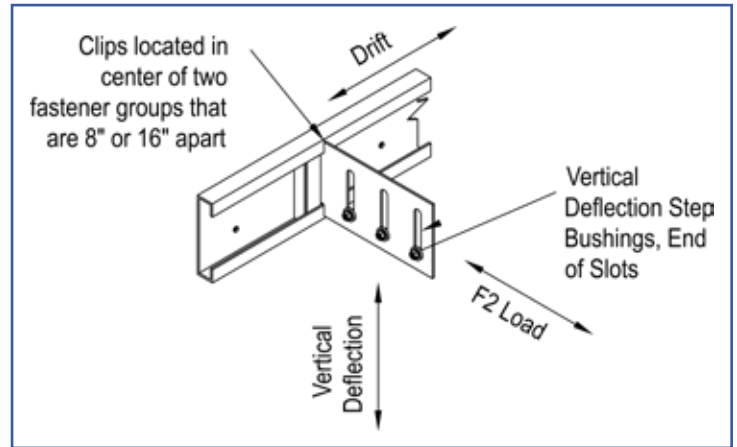
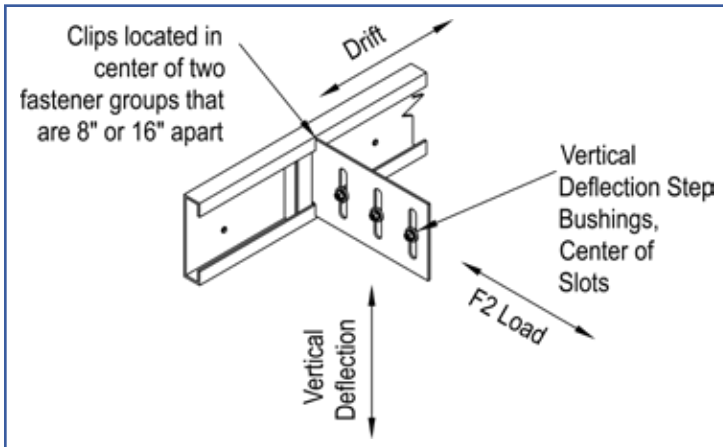

**Fastener Pattern 1** replicates a condition of out-of-plane wind or seismic force with no vertical live load deflection and full in-plane drift.

**Fastener Pattern 2** replicates a condition of out-of-plane wind or seismic force with full vertical live load deflection and full in-plane drift.

**Locking of Lateral Movement After Panel Installation**

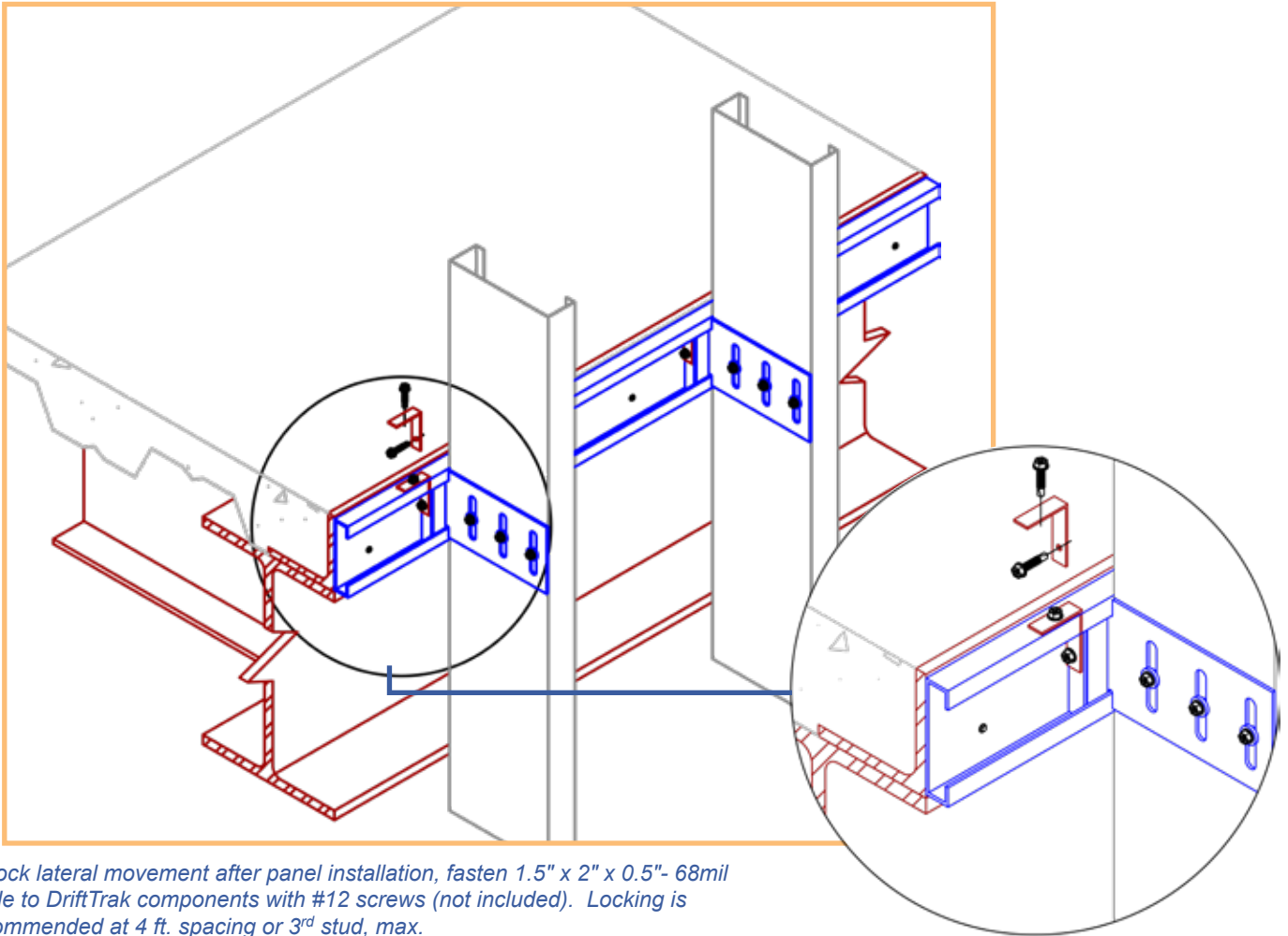

To lock lateral movement after panel installation, fasten 1.5" x 2" x 0.5" - 68mil angle to DriftTrak components with #12 screws (not included). Locking is recommended at 4 ft. spacing or 3<sup>rd</sup> stud, max.



DriftTrak DT w/ DTSLB-HD362/400,  
DTSLB600 & DTSLB800  
ICC-ESR-2049  
www.icc-es.org

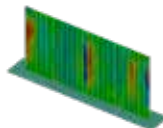

DriftTrak DT w/ DTSLB-HD Series  
Blast and Seismic Design Data  
www.steelnetwork.com

\*\* For more information or to review a copy of each of these reports, please visit our website at <http://www.steelnetwork.com/light-steel-framing-design-resources>

# DriftTrak® DT w/DTLB

Bypass Slab

The Steel Network, Inc.

www.steelnetwork.com

1-888-474-4876



## Material Composition

**Clip Material:** ASTM A1003/A1003M Structural Grade 50 (340) Type H, ST50H (ST340H): 50ksi (340MPa) minimum yield strength, 65ksi (450MPa) minimum tensile strength, 97mil minimum thickness (12 gauge, 0.1017" design thickness) with ASTM A653/A653M G90 (Z275) hot dipped galvanized coating.

**Track Material:** ASTM A1003/A1003M Structural Grade 50 (340) Type H, ST50H (ST340H): 50ksi (340MPa) minimum yield strength, 65ksi (450MPa) minimum tensile strength, 97mil minimum thickness (12 gauge, 0.1017" design thickness) with ASTM A653/A653M G60 (Z180) hot dipped galvanized coating.

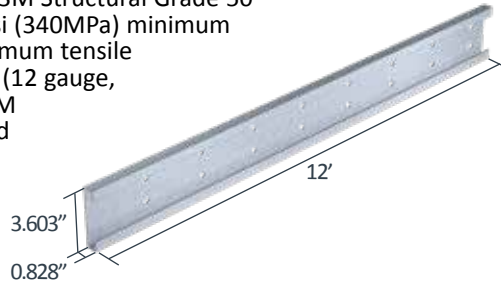
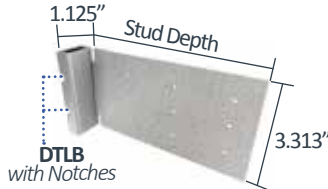

US Patent #7,503,150

## DriftTrak DT w/ DTLB Allowable (Unfactored) Loads

DriftTrak® DT w/ DTLB, Recommended Allowable Load (lbs): F2 & F3														
Screw Patterns with #12 Screws	F2 Load Direction						F3 Load Direction							
	DTLB362/400 Max Offset = 1"		DTLB600 & DTLB800 Max. Offset = 1" for DTLB600 Max. Offset = 1" for DTLB800 w/ 8" Studs Max. Offset = 3" for DTLB800 w/ 6" Studs				DTLB362/400 Max. Offset = 1"		DTLB600 Max. Offset = 1" for DTLB800 w/ 8" Studs Max. Offset = 3" for DTLB800 w/ 6" Studs			DTLB800 Max. Offset = 1" for DTLB800 w/ 8" Studs Max. Offset = 3" for DTLB800 w/ 6" Studs		
	4 Screws	6 Screws	4 Screws	6 Screws	9 Screws	4 Screws	6 Screws	4 Screws	6 Screws	9 Screws	4 Screws	6 Screws	9 Screws	
33mil (20ga), 33ksi stud	752	1,009	752	1,128	1,197	228	309	258	309	433	226	264	375	
33mil (20ga), 50ksi stud	1,009	1,009	1,088	1,197	1,197	330	448	373	447	627	327	382	543	
43mil (18ga), 33ksi stud	1,009	1,009	1,120	1,197	1,197	340	461	384	460	645	337	393	559	
43mil (18ga), 50ksi stud	1,009	1,009	1,197	1,197	1,197	492	667	555	666	933	487	568	809	
54mil (16ga), 33ksi stud	1,009	1,009	1,197	1,197	1,197	478	649	540	648	908	474	553	787	
54mil (16ga), 50ksi stud	1,009	1,009	1,197	1,197	1,197	691	937	780	936	1,312	685	799	1,136	
68mil (14ga), 50ksi stud	1,009	1,009	1,197	1,197	1,197	870	1,163	982	1,179	1,653	863	1,006	1,272	
97mil (12ga), 50ksi stud	1,009	1,009	1,197	1,197	1,197	870	1,163	982	1,179	1,653	863	1,006	1,272	
<b>Max Allowable Clip Load</b>	<b>1,009</b>		<b>1,197</b>			<b>1,163</b>		<b>1,750</b>			<b>1,272</b>			

### Notes:

- Design loads are for attachment of DriftTrak DT w/ DTLB to stud only.
- Allowable loads have not been increased for wind, seismic, or other factors.
- Clips are manufactured to fit into DriftTrak DT. DriftTrak DT w/ DTLB provides a rigid connection to the stud while allowing free lateral movement of the structure.
- Torsional effects are considered on screw group for F3 allowable loads. It is assumed that all of the torsional moment is taken by the connection to the stud.
- Loads listed reflect force in a single direction. When multiple loads act on the connection, it is the responsibility of the designer to check the interaction of forces.
- Attachment to structure at 8" spacing to be engineered by others.
- One row of bridging is recommended at a maximum distance of 18" from DriftTrak DT w/ DTLB if no other stud lateral restraint is present.
- Notches are standard in DTLB clips. For greater F2 load capacities, use DTLB-HD clips without notches. Refer to allowable load tables.
- Allow a minimum of 7/8" from the structure to the inside flange of the bypassing stud to allow for track attachment.
- Maximum total offset of stud from the edge of slab should not exceed 1" for DriftTrak DT w/ DTLB362/400 or DTLB600 clips.
- Maximum total offset of stud from the edge of slab should not exceed 1" for DriftTrak DT w/ DTLB800 clips with 8" studs and 3" for DriftTrak DT w/ DTLB800 clips with 6" studs.
- Maximum total offset is measured as track flange plus the gap from the open face of the track to the inside face of the stud.
- For LRFD strengths contact TSN technical services.

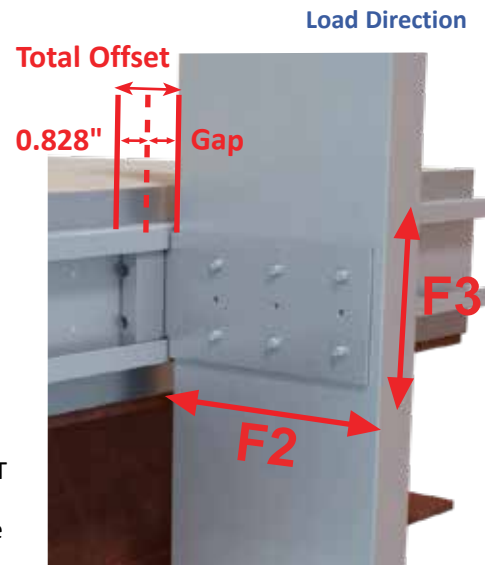

**Nomenclature**

DriftTrak DT w/ DTLB is specified by designating the track section and the clip size by multiplying the stud depth by 100.

**Example:** Track fastened at 8", 6" stud depth, with an outward load (F2) of 1,000 lbs and a gravity load (F3) of 400 lbs

**Designate:** DriftTrak® DT w/ DTLB600

**DTLB362 Fastener Patterns**

**DTLB600 and DTLB800 Fastener Patterns**



4 Hole Fastener Pattern

6 Hole Fastener Pattern

4 Hole Fastener Pattern

6 Hole Fastener Pattern

9 Hole Fastener Pattern

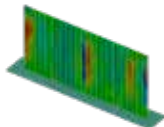
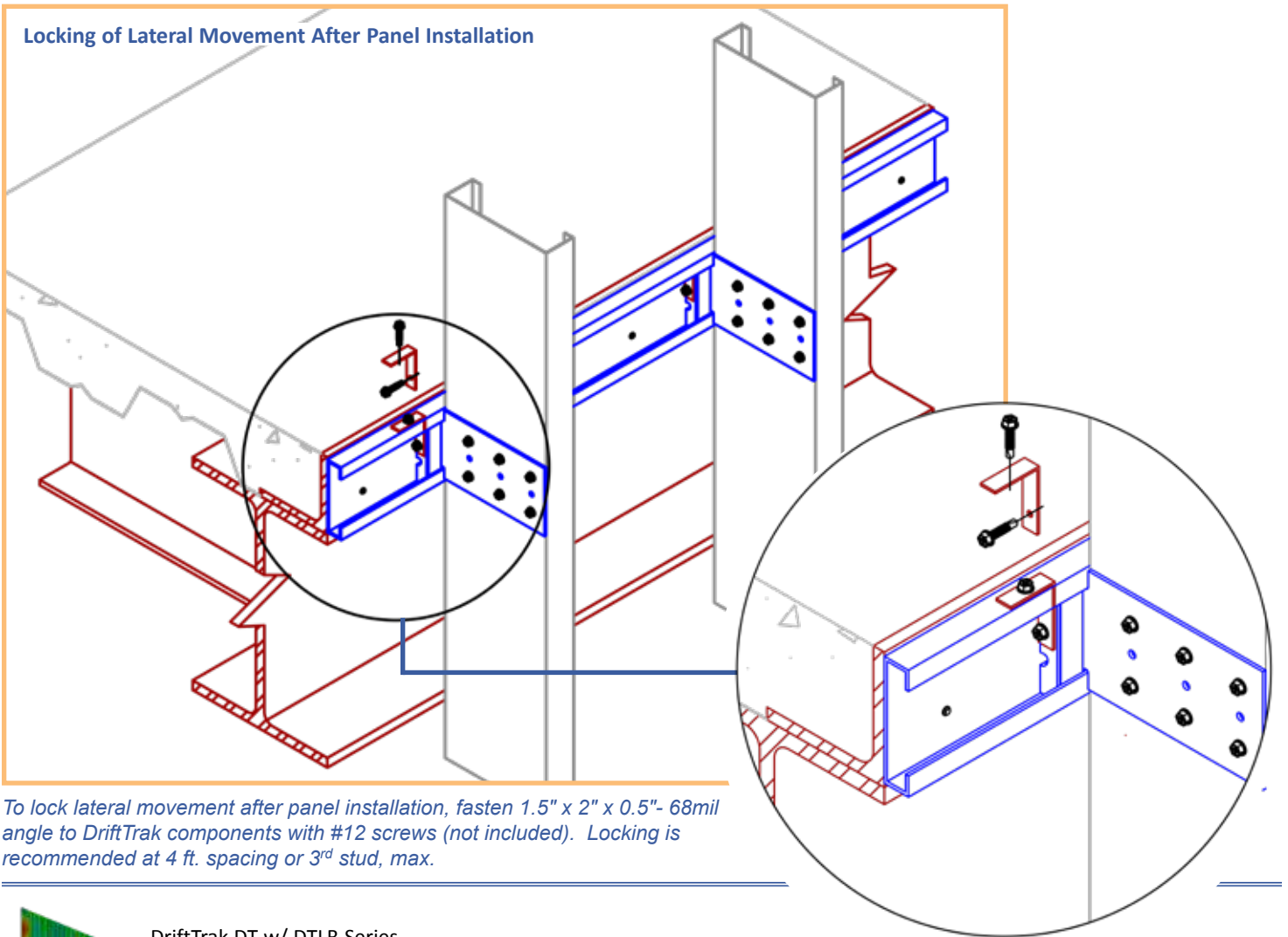

DriftTrak DT w/ DTLB Series  
Blast and Seismic Design Data  
www.steelnetwork.com

\*\* For more information or to review a copy of this report, please visit our website at <http://www.steelnetwork.com/light-steel-framing-design-resources>

# DriftTrak® DT w/DTLB-HD

Bypass Slab

The Steel Network, Inc.

www.steelnetwork.com

1-888-474-4876



## Material Composition

**Clip Material:** ASTM A1003/A1003M Structural Grade 50 (340) Type H, ST50H (ST340H): 50ksi (340MPa) minimum yield strength, 65ksi (450MPa) minimum tensile strength, 97mil minimum thickness (12 gauge, 0.1017" design thickness) with ASTM A653/A653M G90 (Z275) hot dipped galvanized coating.

**Track Material:** ASTM A1003/A1003M Structural Grade 50 (340) Type H, ST50H (ST340H): 50ksi (340MPa) minimum yield strength, 65ksi (450MPa) minimum tensile strength, 97mil minimum thickness (12 gauge, 0.1017" design thickness) with ASTM A653/A653M G60 (Z180) hot dipped galvanized coating.

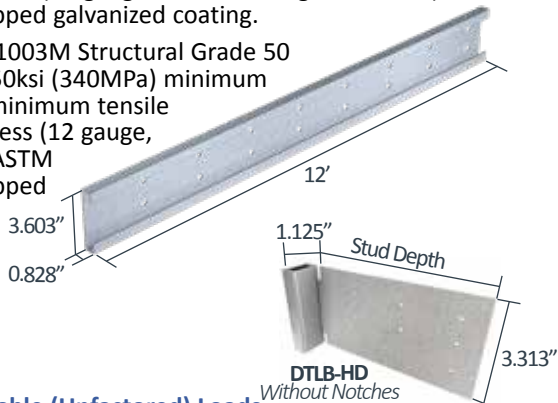

Coordinate location of clips and studs with locations of anchors.



US Patent #7,503,150

## DriftTrak DT w/ DTLB-HD Allowable (Unfactored) Loads

DriftTrak® DT w/ DTLB-HD, Recommended Allowable Load (lbs): F2 & F3													
Screw Patterns with #12 Screws	F2 Load Direction						F3 Load Direction						
	DTLB362/400-HD Max. Offset = 1" for DTLB362/400-HD		DTLB600-HD or DTLB800-HD Max. Offset = 1" for DTLB600-HD Max. Offset = 1" for DTLB800-HD w/ 8" Studs Max. Offset = 3" for DTLB800-HD w/ 6" Studs			DTLB362/400-HD Max. Offset = 1" for DTLB362/400-HD		DTLB600-HD Max. Offset = 1" for DTLB600-HD			DTLB800-HD Max. Offset = 1" for DTLB800-HD w/ 8" Studs Max. Offset = 3" for DTLB800-HD w/ 6" Studs		
	4 Screws	6 Screws	4 Screws	6 Screws	9 Screws	4 Screws	6 Screws	4 Screws	6 Screws	9 Screws	4 Screws	6 Screws	9 Screws
33mil (20ga), 33ksi stud	752	1,128	752	1,128	1,692	228	309	258	309	433	226	264	375
33mil (20ga), 50ksi stud	1,088	1,316	1,088	1,632	1,749	330	448	373	447	627	327	382	543
43mil (18ga), 33ksi stud	1,120	1,316	1,120	1,680	1,749	340	461	384	460	645	337	393	559
43mil (18ga), 50ksi stud	1,316	1,316	1,620	1,749	1,749	492	667	555	666	933	487	568	809
54mil (16ga), 33ksi stud	1,316	1,316	1,576	1,749	1,749	478	649	540	648	908	474	553	787
54mil (16ga), 50ksi stud	1,316	1,316	1,749	1,749	1,749	691	937	780	936	1,312	685	799	1,136
68mil (14ga), 50ksi stud	1,316	1,316	1,749	1,749	1,749	870	1,163	982	1,179	1,653	863	1,006	1,272
97mil (12ga), 50ksi stud	1,316	1,316	1,749	1,749	1,749	870	1,163	982	1,179	1,653	863	1,006	1,272
<b>Max Allowable Clip Load</b>	<b>1,316</b>		<b>1,749</b>			<b>1,163</b>		<b>1,750</b>			<b>1,272</b>		

## Notes:

- Design loads are for attachment of DriftTrak DT w/ DTLB-HD to stud only.
- Allowable loads have not been increased for wind, seismic, or other factors.
- Clips are manufactured to fit into DriftTrak DT. DriftTrak DT w/ DTLB-HD provides a rigid connection to the stud while allowing free lateral movement of the structure.
- Torsional effects are considered on screw group for F3 allowable loads. It is assumed that all of the torsional moment is taken by the connection to the stud.
- Loads listed reflect force in a single direction. When multiple loads act on the connection, it is the responsibility of the designer to check the interaction of forces.
- Attachment to structure at 8" spacing to be engineered by others.
- One row of bridging is recommended at a maximum distance of 18" from DriftTrak DT w/ DTLB-HD if no other stud lateral restraint is present.
- Allow a minimum of 7/8" from the structure to the inside flange of the bypassing stud to allow for track attachment.
- Maximum total offset of stud from the edge of slab should not exceed 1" for DriftTrak DT w/ DTLB362/400-HD or DTLB600-HD clips.
- Maximum total offset of stud from the edge of slab should not exceed 1" for DriftTrak DT w/ DTLB800-HD clips with 8" studs and 3" for DriftTrak DT w/ DTLB800-HD clips with 6" studs.
- Maximum total offset is measured as track flange plus the gap from the open face of the track to the inside face of the stud.
- For LRFD strengths contact TSN technical services.

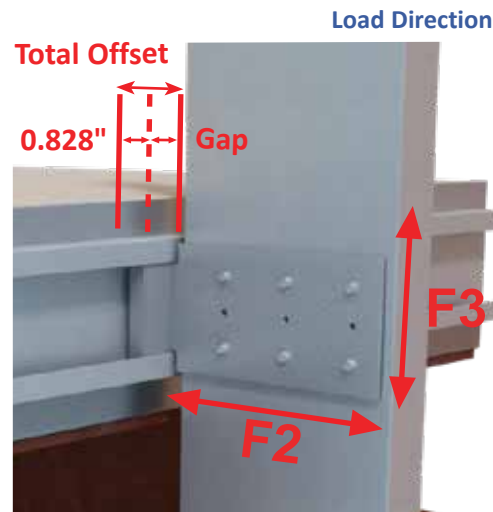

**Nomenclature**

DriftTrak DT w/ DTLB600-HD is classified by multiplying stud depth by 100, followed by "HD," based on F2 strength required. Refer to load tables.

**Example:** Track fastened at 8", 6" stud depth, with an outward load (F2) of 1,000 lbs and a gravity load (F3) of 400 lbs

**Designate:** DriftTrak DT w/ DTLB600-HD

**DTLB362-HD Fastener Patterns**

**DTLB600-HD and DTLB800-HD Fastener Patterns**



4 Hole Fastener Pattern

6 Hole Fastener Pattern

4 Hole Fastener Pattern

6 Hole Fastener Pattern

9 Hole Fastener Pattern

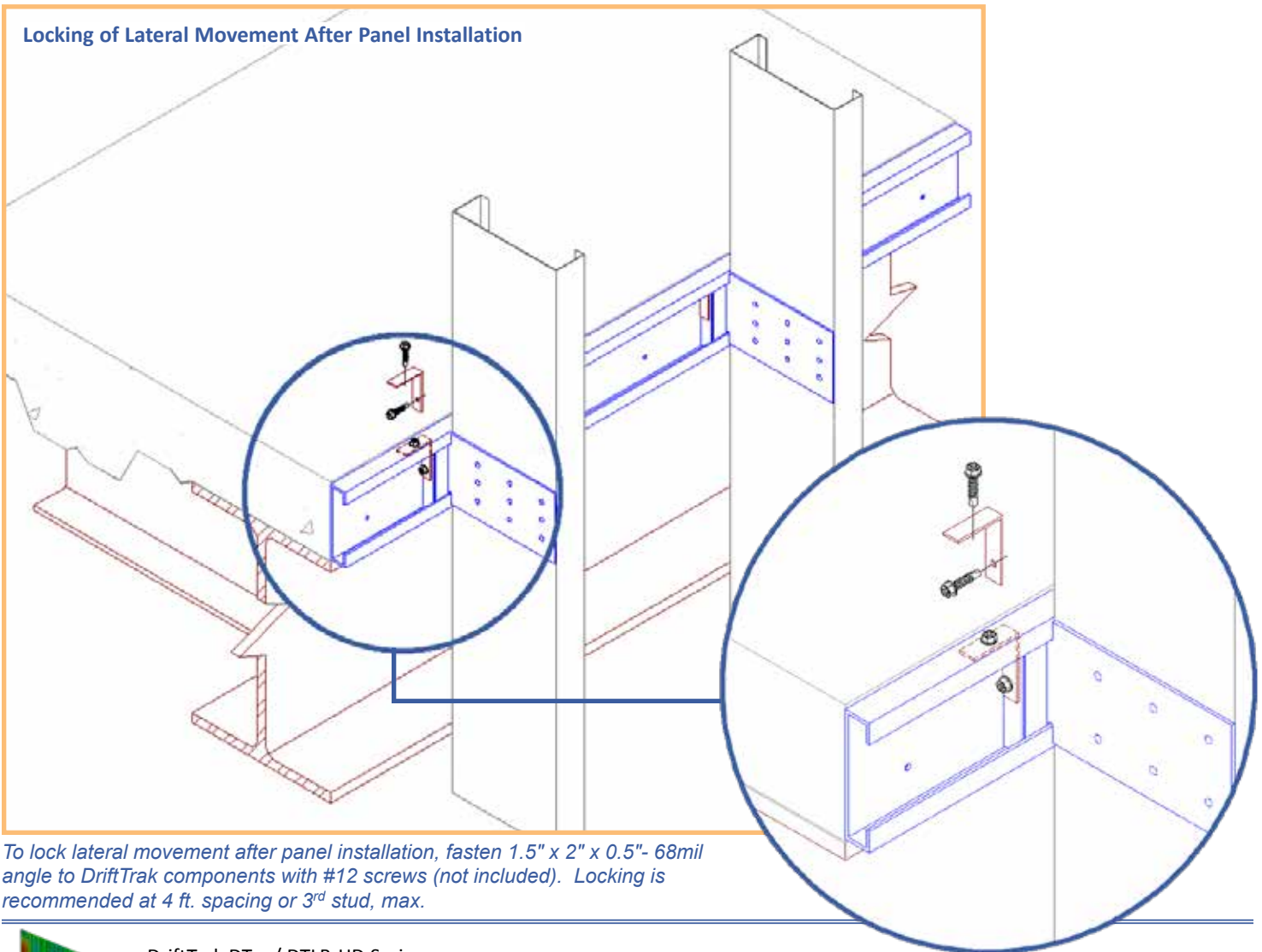

To lock lateral movement after panel installation, fasten 1.5" x 2" x 0.5"- 68mil angle to DriftTrak components with #12 screws (not included). Locking is recommended at 4 ft. spacing or 3<sup>rd</sup> stud, max.

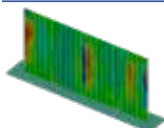

DriftTrak DT w/ DTLB-HD Series  
Blast and Seismic Design Data  
[www.steelnetwork.com](http://www.steelnetwork.com)

\*\* For more information or to review a copy of this report, please visit our website at <http://www.steelnetwork.com/light-steel-framing-design-resources>

# DriftTrak® DTH w/ DTSLB-HD

Slab Integrated Bypass



### Description

DriftTrak® DTH (Headed Stud) w/ DTSLB-HD saves the time and expense of installing DriftTrak after the concrete slab has been poured, by integrating it directly into the slab before pouring. The headed studs come preinstalled to the DriftTrak DTH and function as the attachment to the post-tensioned slab instead of welding to the pour stop angle or use of PAF's or anchors. Once concrete is poured, the DriftTrak DTH is ready to support exterior steel framing using DTSLB-HD bypass clips to accommodate vertical deflection and lateral drift requirements.



US Patent #7,503,150 & Patent Pending

### Material Composition

**Track Material:** ASTM A1003/A1003M Structural Grade 50 (340) Type H, ST50H (ST340H): 50ksi (340MPa) minimum yield strength, 65ksi (450MPa) minimum tensile strength, 97mil minimum thickness (12 gauge, 0.1017" design thickness) with ASTM A653/A653M G60 (Z180) hot dipped galvanized coating.

**Headed Stud Material:** ASTM A29/A108, Grades 1010 through 1020 or equivalent, 45ksi (310MPa) minimum yield strength, 55ksi (380MPa) minimum tensile strength, 3/8" diam. x 3 1/8" length with 3/4" head diameter.

**Clip Material:** ASTM A1003/A1003M Structural Grade 50 (340) Type H, ST50H (ST340H): 50ksi (340MPa) minimum yield strength, 65ksi (450MPa) minimum tensile strength, 97mil minimum thickness (12 gauge, 0.1017" design thickness) with ASTM A653/A653M G90 (Z275) hot dipped galvanized coating.

### DriftTrak DTH w/ DTSLB-HD Allowable Loads

DriftTrak® DTH w/ DTSLB-HD, Recommended Allowable Load (lbs): F2			
Screw Patterns with #12 Screws	F2 Load Direction		
	DTSLB362/400-HD <i>Max. Offset = 1-1/4" for DTSLB362/400-HD</i>	DTSLB600-HD & DTSLB800-HD <i>Max. Offset = 1-1/4" for DTSLB600-HD Max. Offset = 2-1/2" for DTSLB800-HD</i>	
	2 Screws	2 Screws	3 Screws
33mil (20ga), 33ksi stud	376	376	564
33mil (20ga), 50ksi stud	544	544	816
43mil (18ga), 33ksi stud	560	560	840
43mil (18ga), 50ksi stud	810	810	1,215
54mil (16ga), 33ksi stud	788	788	1,182
54mil (16ga), 50ksi stud	1,138	1,138	1,657
68mil (14ga), 50ksi stud	1,434	1,434	1,657
97mil (12ga), 50ksi stud	1,434	1,434	1,657
<b>Max Allowable Clip Load</b>	<b>1,657</b>		

### Load Direction



### Notes:

- Design loads are for attachment of DriftTrak DTH w/ DTSLB-HD to stud and stud weld to track only.
- Allowable loads have not been increased for wind, seismic, or other factors.
- Clips are manufactured to fit into DriftTrak DTH. DriftTrak DTH w/ DTSLB-HD allows up to 2" of vertical deflection (1" up and 1" down), and free lateral movement of the structure.
- #12 screws are provided for each step bushing attachment to studs. Load requirements don't always justify use of a third screw.
- Maximum tension on a single anchor should not exceed 1,600 lbs ASD. In tension, the strength of the anchor itself should be considered. The weld does not need to be considered in tension as the load table and 1,600 lbs ASD maximum tension value are inclusive of the strength of the welds.
- Designers must check headed stud tension anchorage capacity into concrete per ACI 318 based on the actual headed stud edge distance an concrete compressive strength. For more information, call TSN Technical Support.
- One row of bridging is recommended at a maximum distance of 18" from DriftTrak DTH w/ DTSLB-HD to resist torsional effects.
- Standard offset of stud from the open face of the track should not exceed 1-1/4" for DriftTrak DTH w/ DTSLB362/400-HD or DTSLB600-HD clips.
- Standard offset of stud from the open face of the track should not exceed 2-1/2" for DriftTrak DTH w/ DTSLB800-HD clips.
- Offset is measured from the open face of the track to the inside face of the stud.
- For LRFD strengths contact TSN technical services.

**Nomenclature**

DriftTrak DTH is manufactured in 10' or 12' lengths, with headed studs in a single centered row (See DriftTrak® DTH: Dimensions, Layout, and Stud Spacing figure. To specify DriftTrak DTH for a vertical deflection specify DriftTrak DTH and the clip size by multiplying the stud depth by 100.

**Example:** Headed stud track, 6" stud depth, with an outward load (F2) of 1,000 lbs  
**Designate:** DriftTrak DTH w/ DTSLB600-HD

**DriftTrak® DTH: Dimensions, Layout and Stud Spacing**

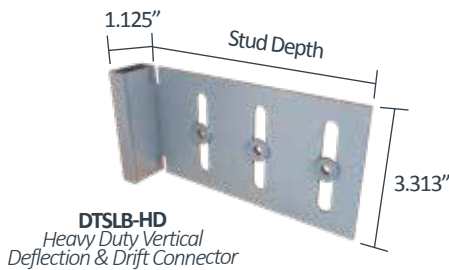
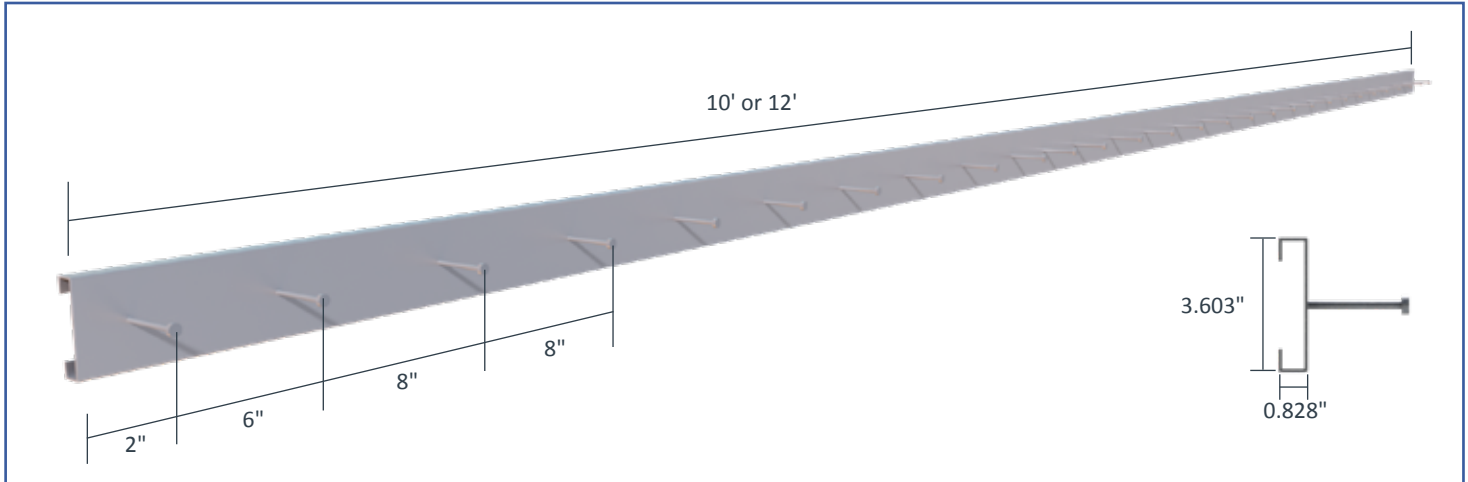

**Fastener Patterns**

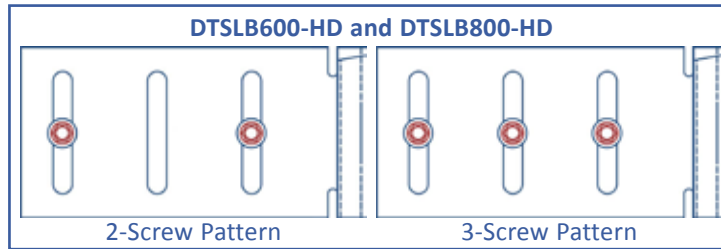
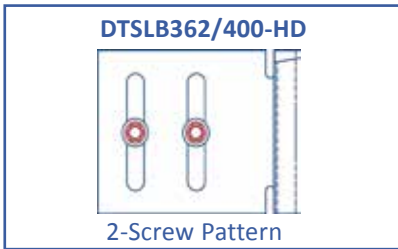

**Example Details**

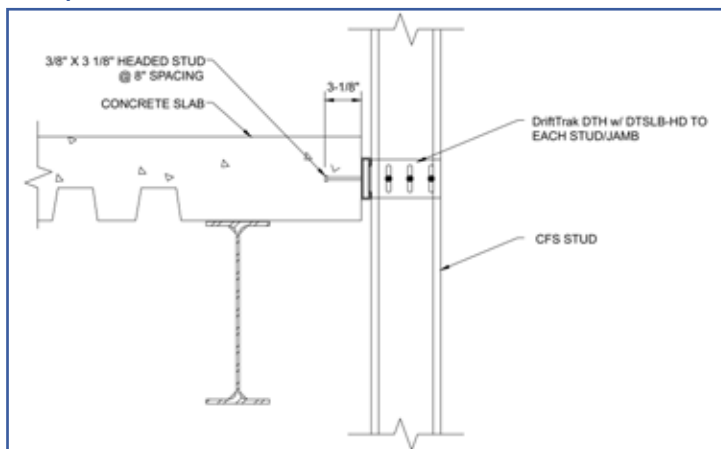

**DriftTrak® DTH w/ DTSLB-HD  
 Attachment to Slab on Metal Deck**

# DriftTrak® DTH w/ DTLB-HD

Slab Integrated Bypass



### Description

DriftTrak® DTH (Headed Stud) w/ DTLB-HD saves the time and expense of installing DriftTrak after the concrete slab has been poured, by integrating it directly into the slab before pouring. The headed studs come preinstalled to the DriftTrak DTH and function as the attachment to the post-tensioned slab instead of welding to the pour stop angle or use of PAF's or anchors. Once concrete is poured, the DriftTrak DTH is ready to support exterior steel framing to accommodate vertical deflection and lateral drift requirements using DTLB-HD bypass clips to provide a rigid attachment and accommodate lateral drift requirements.



US Patent #7,503,150 & Patent Pending

### Material Composition

**Track Material:** ASTM A1003/A1003M Structural Grade 50 (340) Type H, ST50H (ST340H): 50ksi (340MPa) minimum yield strength, 65ksi (450MPa) minimum tensile strength, 97mil minimum thickness (12 gauge, 0.1017" design thickness) with ASTM A653/A653M G60 (Z180) hot dipped galvanized coating.

**Headed Stud Material:** ASTM A29/A108, Grades 1010 through 1020 or equivalent, 45ksi (310MPa) minimum yield strength, 55ksi (380MPa) minimum tensile strength, 3/8" diam. x 3 3/8" length with 3/4" head diameter.

**Clip Material:** ASTM A1003/A1003M Structural Grade 50 (340) Type H, ST50H (ST340H): 50ksi (340MPa) minimum yield strength, 65ksi (450MPa) minimum tensile strength, 97mil minimum thickness (12 gauge, 0.1017" design thickness) with ASTM A653/A653M G90 (Z275) hot dipped galvanized coating.

### DriftTrak Headed Stud Allowable Loads

DriftTrak® Headed Studs with DTLB-HD, Recommended Allowable Load (lbs): F2 & F3													
	F2 Load Direction					F3 Load Direction							
	DTLB362/400-HD <i>Max. Offset = 1" for DTLB362/400-HD</i>		DTLB600-HD or DTLB800-HD <i>Max. Offset = 1" for DTLB600-HD Max. Offset = 1" for DTLB800-HD</i>			DTLB362/400-HD <i>Max. Offset = 1" for DTLB362/400-HD</i>		DTLB600-HD <i>Max. Offset = 1" for DTLB600-HD</i>			DTLB800-HD <i>Max. Offset = 1" for DTLB800-HD</i>		
Screw Patterns with #12 Screws	4 Screws	6 Screws	4 Screws	6 Screws	9 Screws	4 Screws	6 Screws	4 Screws	6 Screws	9 Screws	4 Screws	6 Screws	9 Screws
33mil (20ga), 33ksi stud	752	1,128	752	1,128	1,657	228	309	258	309	433	226	264	375
33mil (20ga), 50ksi stud	1,088	1,632	1,088	1,632	1,657	330	448	373	447	627	327	382	543
43mil (18ga), 33ksi stud	1,120	1,657	1,120	1,657	1,657	340	461	384	460	645	337	393	559
43mil (18ga), 50ksi stud	1,620	1,657	1,620	1,657	1,657	492	667	555	666	933	487	568	809
54mil (16ga), 33ksi stud	1,576	1,657	1,576	1,657	1,657	478	649	540	648	908	474	553	787
54mil (16ga), 50ksi stud	1,657	1,657	1,657	1,657	1,657	691	937	780	936	1,312	685	799	1,136
68mil (14ga), 50ksi stud	1,657	1,657	1,657	1,657	1,657	870	1,163	1,065	1,278	1,791	863	1,006	1,272
97mil (12ga), 50ksi stud	1,657	1,657	1,657	1,657	1,657	870	1,163	1,065	1,278	1,791	863	1,006	1,272
<b>Max Allowable Clip Load</b>	<b>1,657</b>		<b>1,657</b>			<b>1,163</b>		<b>1,908</b>			<b>1,272</b>		

### Notes:

- Design loads are for attachment of DriftTrak DTH w/ DTLB-HD to stud only.
- Allowable loads have not been increased for wind, seismic, or other factors.
- Clips are manufactured to fit into DriftTrak DTH. DriftTrak DTH w/ DTLB-HD provides a rigid connection to the stud while allowing free lateral movement of the structure.
- Torsional effects are considered on screw group for F3 allowable loads. It is assumed that all of the torsional moment is taken by the connection to the stud.
- Loads listed reflect force in a single direction. When multiple loads act on the connection, it is the responsibility of the designer to check the interaction of forces.
- Maximum tension on a single anchor should not exceed 1,600 lbs ASD. In tension, the strength of the anchor itself should be considered. The weld does not need to be considered in tension as the load table and 1,600 lbs ASD maximum tension value are inclusive of the strength of the welds.
- Designers must check headed stud tension anchorage capacity into concrete per ACI 318 based on the actual headed stud edge distance and concrete compressive strength. For more information, call TSN Technical Support.
- One row of bridging is recommended at a maximum distance of 18" from DriftTrak DTH w/ DTLB-HD if no other stud lateral restraint is present.
- Standard offset of stud from the open face of the track should not exceed 1" for DriftTrak DTH w/ DTLB362/400-HD, DTLB600-HD, or DTLB800-HD clips.
- Offset is measured from the open face of the track to the inside face of the stud.
- For LRFD strengths contact TSN technical services.

### Load Direction

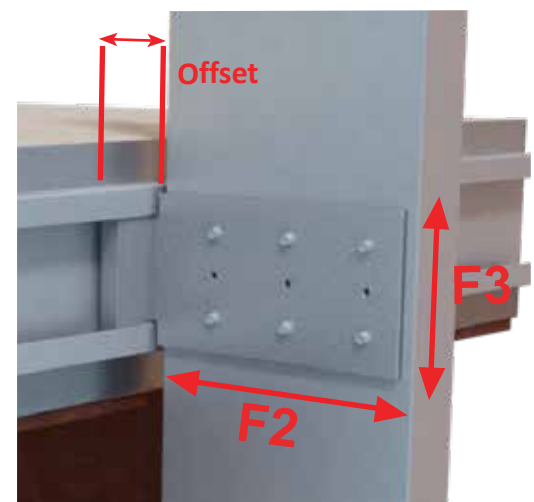

**Nomenclature**

DriftTrak DTH is manufactured in 10' or 12' lengths, with headed studs in a single centered row (See DriftTrak® DTH: Dimensions, Layout, and Stud Spacing figure. To specify DriftTrak DTH for rigid connections specify DriftTrak DTH and the clip size by multiplying the stud depth by 100.

**Example:** Track fastened at 8", 6" stud depth, with an outward load (F2) of 1,000 lbs and a gravity load (F3) of 400 lbs  
**Designate:** DriftTrak DT w/ DTLB600-HD

**DriftTrak® DTH: Dimensions, Layout and Stud Spacing**

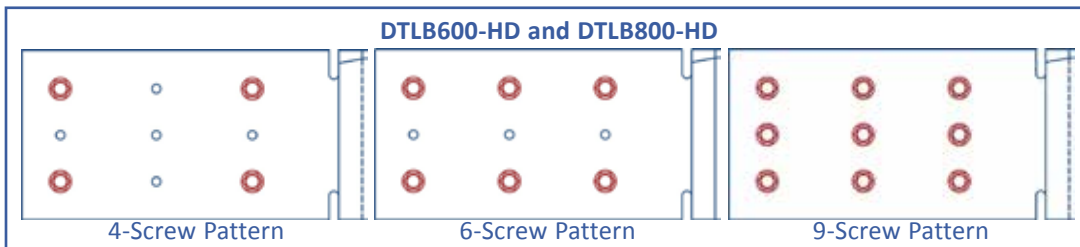
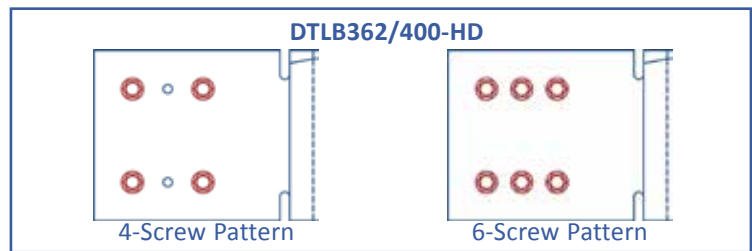
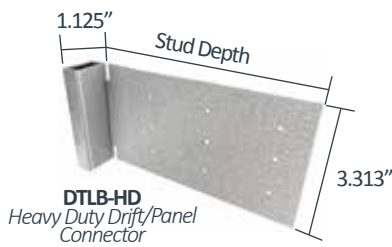
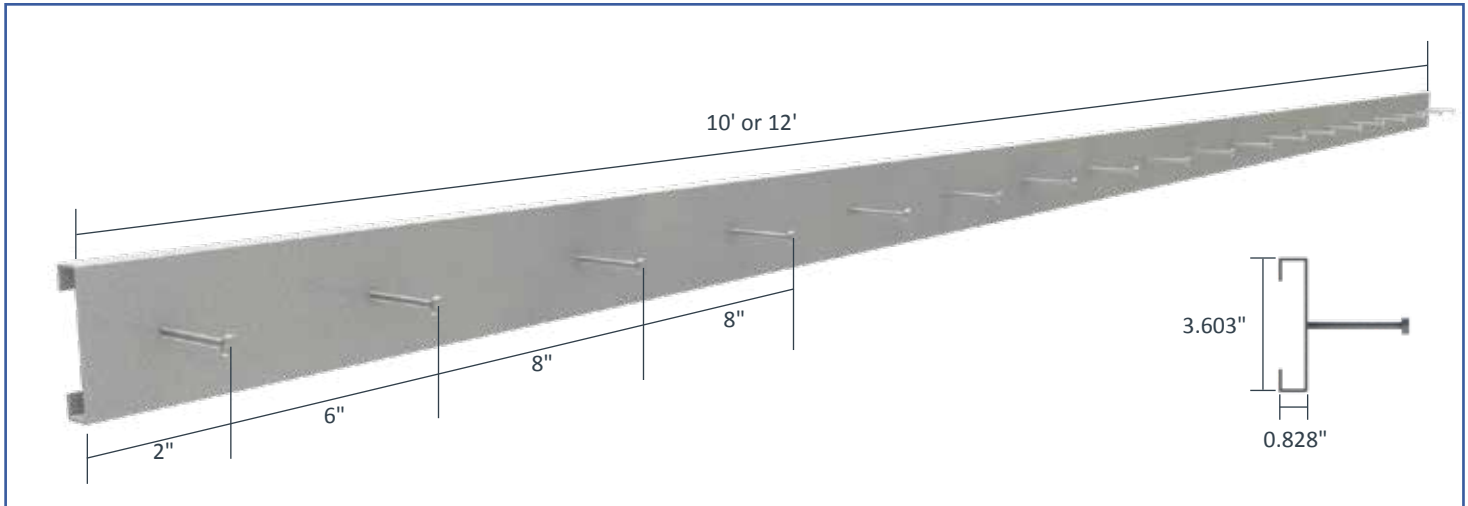

**Example Details**

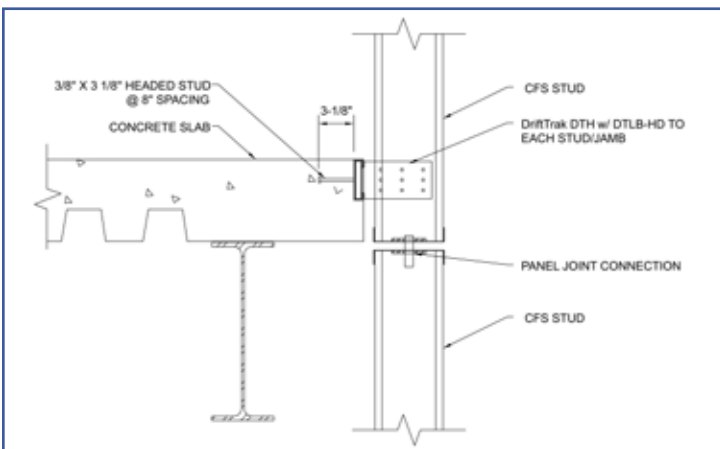

**DriftTrak® DTH w/ DTLB-HD  
 Top Attachment - Slab Insert**

# DriftTrak® PTS w/ DTSLB-PTS

Slab Integrated Bypass - Post Tensioned Concrete Slabs

The Steel Network, Inc.   
www.steelnetwork.com  
1-888-474-4876

## Description

DriftTrak® PTS saves the time and expense of installing DriftTrak after the Post-Tensioned Concrete Slab (PTS) has been poured by integrating it directly into the slab before pouring. The headed studs come preinstalled to the DriftTrak PTS and function as the embedded anchorage to the post-tensioned slab instead of anchoring to a steel edge angle or post-installing concrete anchors. The DriftTrak PTS is sized to fit above or below the high-strength tendon reinforcing at edges of slabs. Once concrete is poured, the DriftTrak PTS is ready to support exterior steel framing using DTSLB-PTS bypass clips to accommodate vertical deflection and lateral drift requirements.



US Patent #7,503,150 & Patent Pending

## Material Composition

**Track Material:** ASTM A1003/A1003M Structural Grade 50 (340) Type H, ST50H (ST340H): 50ksi (340MPa) minimum yield strength, 65ksi (450MPa) minimum tensile strength, 97mil minimum thickness (12 gauge, 0.1017" design thickness) with ASTM A653/A653M G60 (Z180) hot dipped galvanized coating.

**Headed Stud Material:** ASTM A29/A108, Grades 1010 through 1020 or equivalent, 49ksi (340MPa) minimum yield strength, 61ksi (420MPa) minimum tensile strength, 3/8" diam. x 3 1/8" length with 3/4" head diameter.

**DTSLB-PTS Clip Material:** ASTM A1003/A1003M Structural Grade 50 (340) Type H, ST50H (ST340H): 50ksi (340MPa) minimum yield strength, 65ksi (450MPa) minimum tensile strength, 97mil minimum thickness (12 gauge, 0.1017" design thickness) with ASTM A653/A653M G90 (Z275) hot dipped galvanized coating.

## DriftTrak PTS & DTSLB-PTS Connector Nomenclature

DriftTrak® PTS is manufactured in 10' or 12' lengths, with headed studs welded in a single row (see drawing below). DTSLB-PTS clip connectors are inserted and rotated into place inside the DriftTrak PTS to better facilitate panel installation while accommodating vertical deflection and lateral drift requirements in floor slab bypass conditions. Connectors are sold separately, and paired with DriftTrak PTS to support 6" and 8" stud framing. The connectors are classified by multiplying the stud depth by 100, followed by "PTS", then "-L" for a Left version or "-R" for a Right version.

**Example:** Vertical Deflection required, left version required for installation with 6" stud  
**Designate:** DriftTrak® PTS w/ DTSLB600-PTS-L

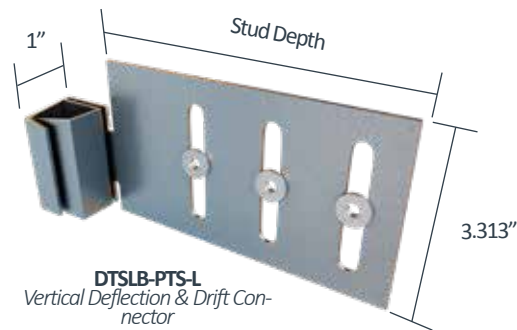

\* Clip shown is left version of DTSLB-PTS.  
Right side version is available for order as standard parts.  
\*\* Clips and track sold separately.

## DriftTrak® PTS: Dimensions, Layout and Stud Spacing

Standard PTS-10ft includes (8) pre-drilled installation guideholes  
Standard PTS-12ft includes (10) pre-drilled installation guideholes

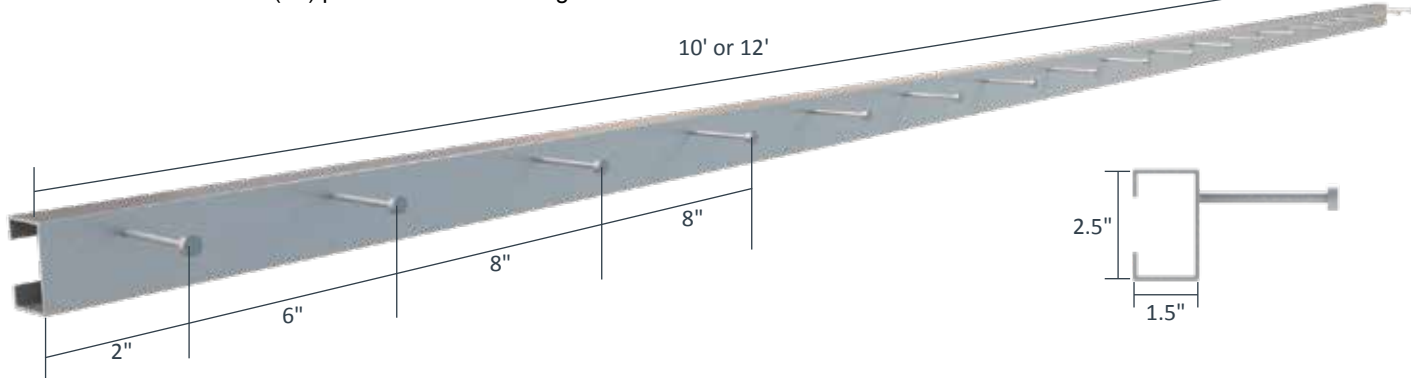

**DriftTrak® PTS w/ DTSLB-PTS Allowable Loads**

Screw Patterns with #12 Screws	F2 Load Direction			
	DTSLB600-PTS & DTSLB800-PTS Max. Offset = 1-7/8" for DTSLB600-PTS Max. Offset = 2-1/2" for DTSLB800-PTS			
	Bottom of Slab		Top of Slab	
	2 Screws	3 Screws	2 Screws	3 Screws
33mil (20ga), 33ksi stud	376	564	376	564
33mil (20ga), 50ksi stud	544	816	544	816
43mil (18ga), 33ksi stud	560	840	560	840
43mil (18ga), 50ksi stud	810	1,080	810	1,215
54mil (16ga), 33ksi stud	788	1,080	788	1,182
54mil (16ga), 50ksi stud	1,080	1,080	1,138	1,595
68mil (14ga), 50ksi stud	1,080	1,080	1,434	1,595
97mil (12ga), 50ksi stud	1,080	1,080	1,434	1,595
<b>Max Allowable Clip Load</b>	<b>1,080</b>		<b>1,595</b>	

**Load Direction**

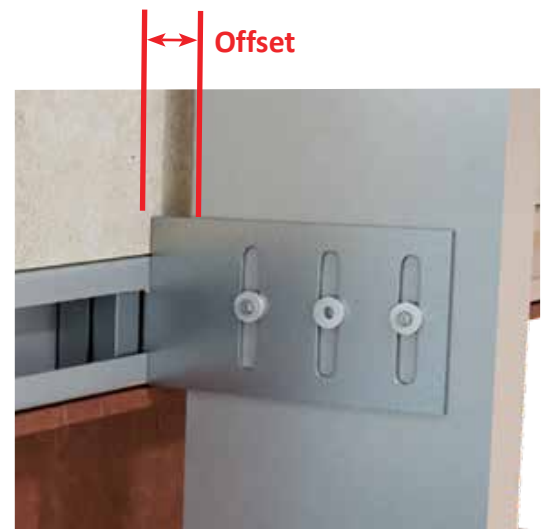

**Notes:**

1. Design loads are for attachment of DriftTrak PTS w/ DTSLB-PTS to stud and stud weld to track only.
2. Allowable loads have not been increased for wind, seismic, or other factors.
3. Clips are manufactured to fit into DriftTrak PTS. DriftTrak PTS w/ DTSLB-PTS allows up to 2" of vertical deflection (1" up and 1" down), and free lateral movement of the structure.
4. #12 screws are provided for each step bushing attachment to studs. Load requirements don't always justify use of a third screw.
5. Maximum tension on a single anchor should not exceed 1,600 lbs ASD. In tension, the strength of the anchor itself should be considered. The weld does not need to be considered in tension as the load table and 1,600 lbs ASD maximum tension value are inclusive of the strength of the welds.
6. Designers must check headed stud tension anchorage capacity into concrete per ACI 318 based on the actual headed stud edge distance an concrete compressive strength. For more information, call TSN Technical Support.
7. One row of bridging is recommended at a maximum distance of 18" from DriftTrak PTS w/ DTSLB-PTS to resist torsional effects.
8. Standard offset of stud from the open face of the track should not exceed 1-7/8" for DriftTrak PTS w/ DTSLB600-PTS clips.
9. Standard offset of stud from the open face of the track should not exceed 2-1/2" for DriftTrak PTS w/ DTSLB800-PTS clips.
10. Offset is measured from the open face of the track to the inside face of the stud.
11. For LRFD strengths contact TSN technical services.

**Fastener Patterns**

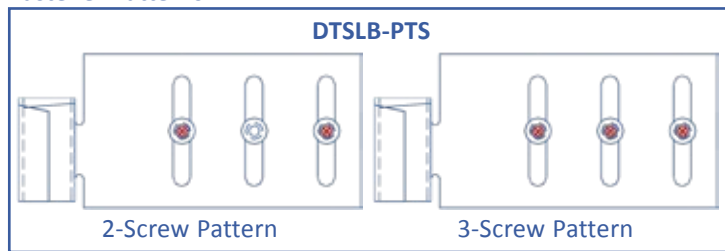

**Example Details**

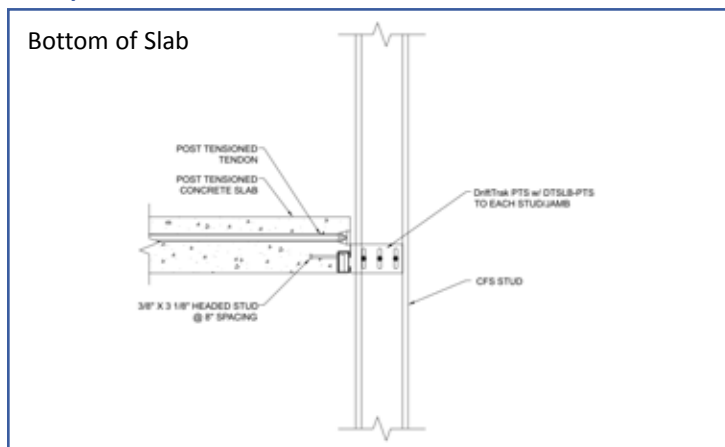

**DriftTrak® PTS w/ DTSLB-PTS:  
Attachment to Post-Tensioned Concrete Slab**

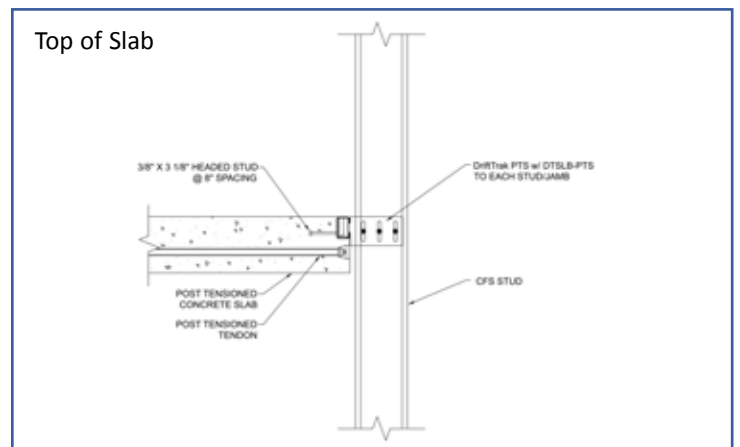

**DriftTrak® PTS w/ DTSLB-PTS:  
Attachment to Post-Tensioned Concrete Slab**

# DriftTrak® PTS w/ DTLB-PTS

Slab Integrated Bypass - Post Tensioned Concrete Slabs

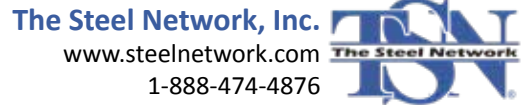

## Description

DriftTrak® PTS saves the time and expense of installing DriftTrak after the Post-Tensioned Concrete Slab (PTS) has been poured by integrating it directly into the slab before pouring. The headed studs come preinstalled to the DriftTrak PTS and function as the embedded anchorage to the post-tensioned slab instead of anchoring to a steel edge angle or post-installing concrete anchors. The DriftTrak PTS is sized to fit above or below the high-strength tendon reinforcing at edges of slabs. Once concrete is poured, the DriftTrak PTS is ready to support exterior steel framing using DTLB-PTS bypass clips to accommodate vertical deflection, accommodate lateral drift requirements, and provide a rigid attachment to the floor slab.



US Patent #7,503,150 & Patent Pending

## Material Composition

**Track Material:** ASTM A1003/A1003M Structural Grade 50 (340) Type H, ST50H (ST340H): 50ksi (340MPa) minimum yield strength, 65ksi (450MPa) minimum tensile strength, 97mil minimum thickness (12 gauge, 0.1017" design thickness) with ASTM A653/A653M G60 (Z180) hot dipped galvanized coating.

**Headed Stud Material:** ASTM A29/A108, Grades 1010 through 1020 or equivalent, 49ksi (340MPa) minimum yield strength, 61ksi (420MPa) minimum tensile strength, 3/8" diam. x 3 1/8" length with 3/4" head diameter.

**DTLB-PTS Clip Material:** ASTM A1003/A1003M Structural Grade 50 (340) Type H, ST50H (ST340H): 50ksi (340MPa) minimum yield strength, 65ksi (450MPa) minimum tensile strength, 97mil minimum thickness (12 gauge, 0.1017" design thickness) with ASTM A653/A653M G90 (Z275) hot dipped galvanized coating.

## DriftTrak PTS & DTLB-PTS Connector Nomenclature

DriftTrak® PTS is manufactured in 10' or 12' lengths, with headed studs welded in a single row (see drawing below). DTLB-PTS clip connectors are inserted and rotated into place inside the DriftTrak PTS to better facilitate panel installation while accommodating vertical deflection, accommodating lateral drift requirements, and providing a rigid attachment to the floor slab in bypass conditions. Connectors are sold separately, and paired with DriftTrak PTS to support 6" and 8" stud framing. The connectors are classified by multiplying the stud depth by 100, followed by "PTS", then "-L" for a Left version or "-R" for a Right version.

**Example:** Rigid connection required, left version required for installation with 6" stud

**Designate:** DriftTrak® PTS w/ DTLB600-PTS-L

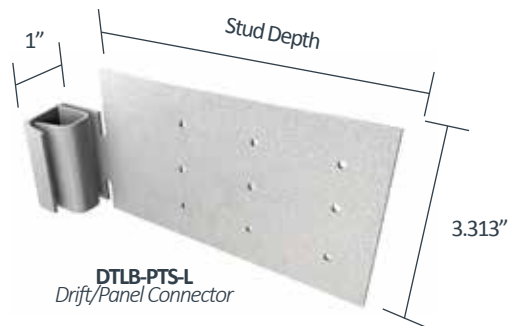

\* Clip shown is left version of DTLB-PTS.

Right side version is available for order as standard parts.

\*\* Clips and track sold separately.

## DriftTrak® PTS: Dimensions, Layout and Stud Spacing

Standard PTS-10ft includes (8) pre-drilled installation guideholes  
 Standard PTS-12ft includes (10) pre-drilled installation guideholes

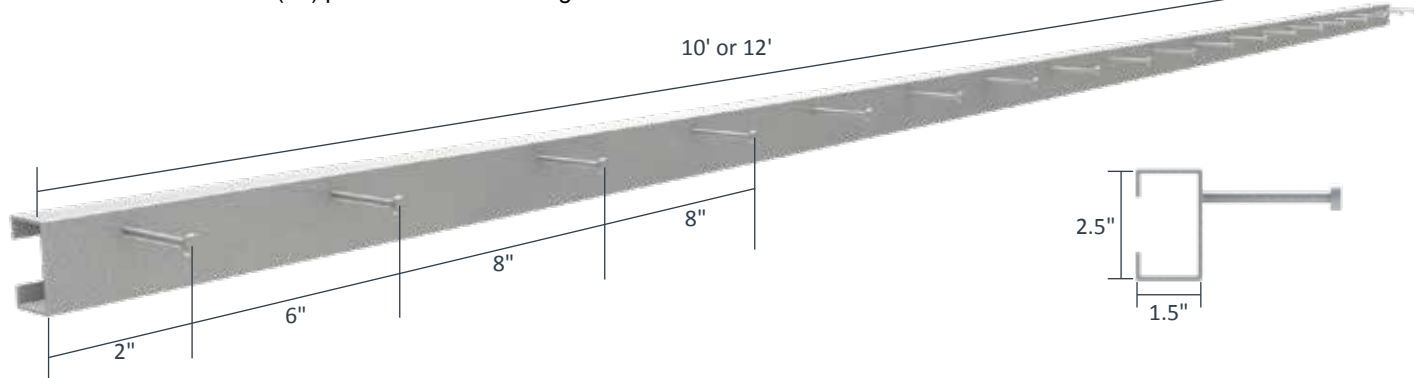

**DriftTrak® PTS w/ DTLB-PTS Allowable Loads**

Screw Patterns with #12 Screws	F2 Direction											
	Bottom of Slab Installation						Top of Slab Installation					
	DTLB600-PTS <i>Max. Offset = 1-7/8"</i>			DTLB800-PTS <i>Max. Offset = 2-1/2"</i>			DTLB600-PTS <i>Max. Offset = 1-7/8"</i>			DTLB800-PTS <i>Max. Offset = 2-1/2"</i>		
	4 Screws	6 Screws	9 Screws	4 Screws	6 Screws	9 Screws	4 Screws	6 Screws	9 Screws	4 Screws	6 Screws	9 Screws
33mil (20ga), 33ksi stud	665	956	1,136	700	1,017	1,110	665	956	1,354	700	1,017	1,326
33mil (20ga), 50ksi stud	963	1,136	1,136	1,013	1,110	1,110	963	1,354	1,354	1,013	1,326	1,326
43mil (18ga), 33ksi stud	991	1,136	1,136	1,043	1,110	1,110	991	1,354	1,354	1,043	1,326	1,326
43mil (18ga), 50ksi stud	1,136	1,136	1,136	1,110	1,110	1,110	1,354	1,354	1,354	1,326	1,326	1,326
54mil (16ga), 33ksi stud	1,136	1,136	1,136	1,110	1,110	1,110	1,354	1,354	1,354	1,326	1,326	1,326
54mil (16ga), 50ksi stud	1,136	1,136	1,136	1,110	1,110	1,110	1,354	1,354	1,354	1,326	1,326	1,326
68mil (14ga), 50ksi stud	1,136	1,136	1,136	1,110	1,110	1,110	1,354	1,354	1,354	1,326	1,326	1,326
97mil (12ga), 50ksi stud	1,136	1,136	1,136	1,110	1,110	1,110	1,354	1,354	1,354	1,326	1,326	1,326
<b>Max Allowable Clip Load</b>	<b>1,136</b>			<b>1,110</b>			<b>1,354</b>			<b>1,326</b>		

Screw Patterns with #12 Screws	F3 Direction					
	Bottom and Top of Slab Installation					
	DTLB600-PTS <i>Max. Offset = 1-7/8"</i>			DTLB800-PTS <i>Max. Offset = 2-1/2"</i>		
	4 Screws	6 Screws	9 Screws	4 Screws	6 Screws	9 Screws
33mil (20ga), 33ksi stud	202	243	331	210	243	345
33mil (20ga), 50ksi stud	293	351	479	303	352	500
43mil (18ga), 33ksi stud	301	362	493	312	362	514
43mil (18ga), 50ksi stud	436	523	713	452	523	744
54mil (16ga), 33ksi stud	424	509	693	439	509	724
54mil (16ga), 50ksi stud	613	735	1,001	635	735	1,000
68mil (14ga), 50ksi stud	772	926	1,064	800	927	1,000
97mil (12ga), 50ksi stud	772	926	1,064	800	927	1,000
<b>Max Allowable Clip Load</b>	<b>1,064</b>			<b>1,000</b>		

Load Direction

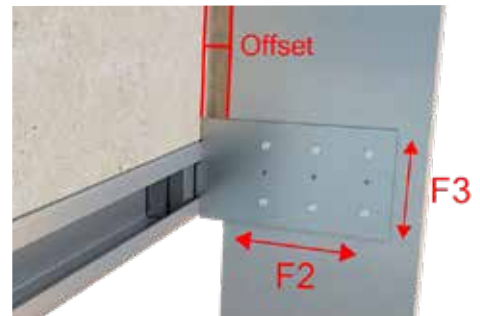

Fastener Patterns

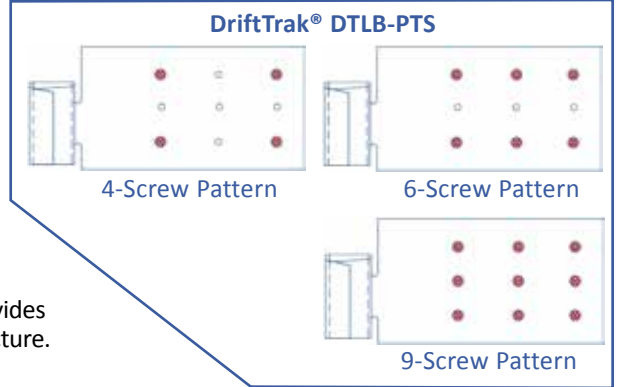

**Notes:**

- Design loads are for attachment of DriftTrak PTS w/ DTLB-PTS to stud and stud weld to track only.
- Allowable loads have not been increased for wind, seismic, or other factors.
- Clips are manufactured to fit into DriftTrak PTS. DriftTrak PTS w/ DTLB-PTS provides a rigid connection to the stud while allowing free lateral movement of the structure.
- Torsional effects are considered on screw group for F3 allowable loads. It is assumed that all of the torsional moment is taken by the connection to the stud.
- Loads listed reflect force in a single direction. When multiple loads act on the connection, it is the responsibility of the designer to check the interaction of forces.
- Maximum tension on a single anchor should not exceed 1,600 lbs ASD. In tension, the strength of the anchor itself should be considered. The weld does not need to be considered in tension as the load table and 1,600 lbs ASD maximum tension value are inclusive of the strength of the welds.
- Designers must check headed stud tension anchorage capacity into concrete per ACI 318 based on the actual headed stud edge distance an concrete compressive strength. For more information, call TSN Technical Support.
- One row of bridging is recommended at a maximum distance of 18" from DriftTrak PTS w/ DTLB-PTS if no other stud lateral restraint is present.
- Standard offset of stud from the open face of the track should not exceed 1-7/8" for DriftTrak PTS w/ DTLB600-PTS clips.
- Standard offset of stud from the open face of the track should not exceed 2-1/2" for DriftTrak PTS w/ DTLB800-PTS clips.
- Offset is measured from the open face of the track to the inside face of the stud.
- For LRFD strengths contact TSN technical services.

**Example Details**

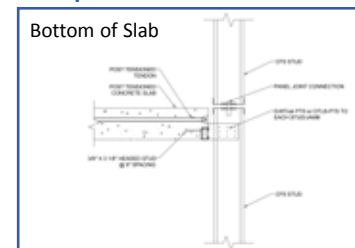

**DriftTrak® DTLB-PTS with Headed Studs: Attachment to Post-Tensioned Concrete Slab**

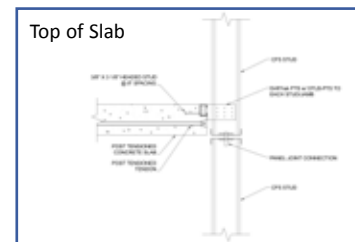

**DriftTrak® DTLB-PTS with Headed Studs: Attachment to Post-Tensioned Concrete Slab**

# BRIDGING THE GAP Between Quality & Speed

with **TSN's** Bridging Connections & Members

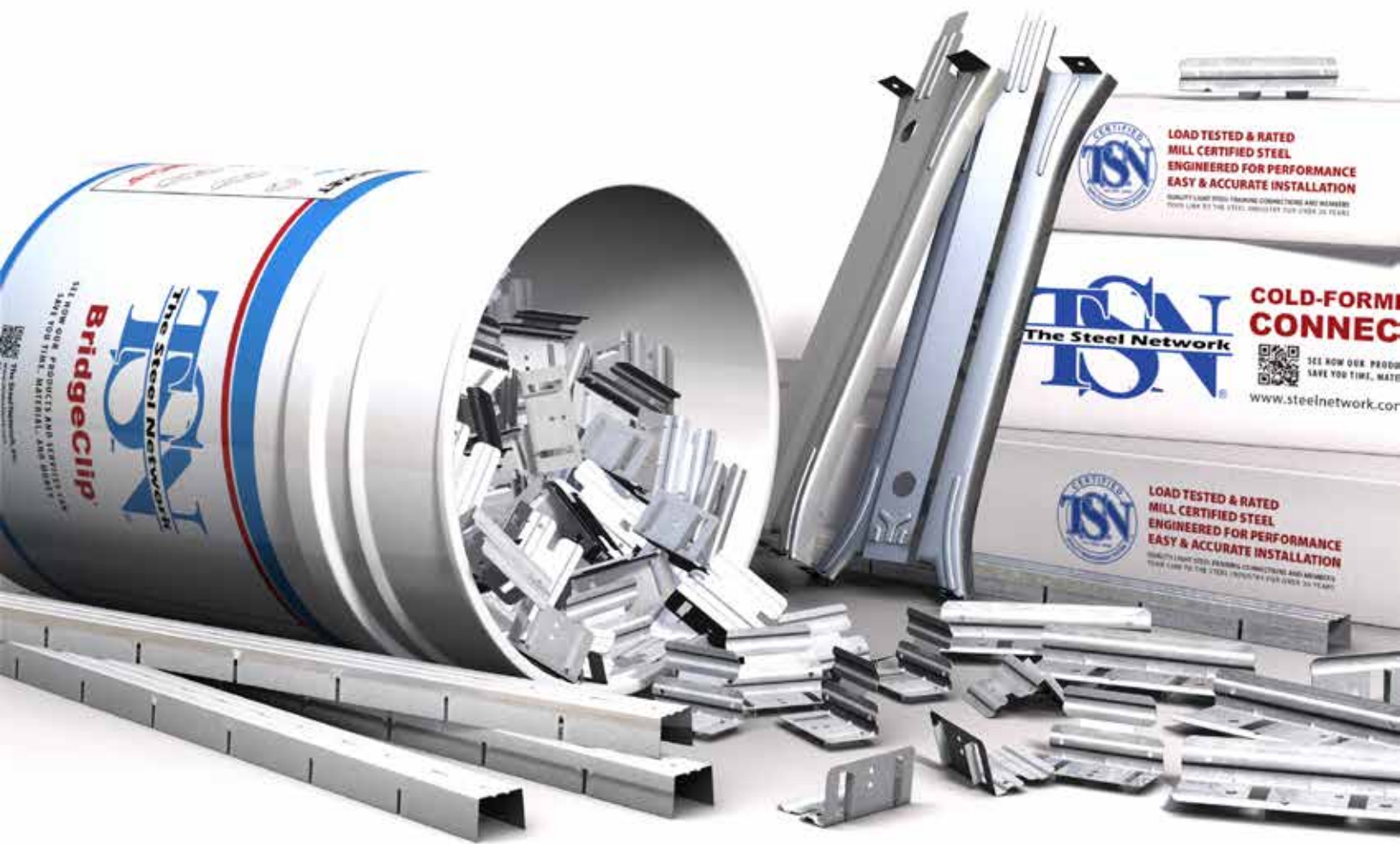

Just one of TSN's complete line of quality,  
**load tested & rated light steel framing  
connections & members.**

Quick Installation · Long Term Performance · It's What's Inside That Counts



(888) 474-4876

[www.steelnetwork.com](http://www.steelnetwork.com)

Manufacturing Quality Connections & Members for Over 20 Years



© 2016 The Steel Network, Inc. All rights reserved. BridgeClip®, BridgeBar® and BuckleBridge® are a registered trademarks of The Steel Network, Inc.

# Wall Bridging

## Background

### Bridging Background

Bridging for load bearing and curtain wall studs is needed to resist the following forces:

- 1 - Weak axis buckling induced by axial compression load.
- 2 - Torsion induced by wind load.

As axial compression and lateral wind loads are applied, wall studs react with weak axis buckling and torsional rotation. To offset these forces, a form of bridging is incorporated into the wall system. Bridging loads accumulate over the run of the wall, requiring transfer of lateral forces in bridging at columns or to the floor slab into the structural load path to the foundation.

AISI S100 (Specification) and AISI S240 (Standard For Structural Framing) provide the load and stiffness requirements for bracing members due to the effects of axial compression load and wind load as given in the table below. Contact TSN Technical Support if further information is needed regarding wall bridging design.

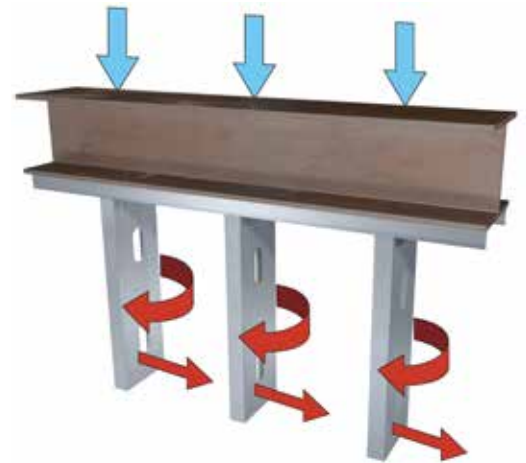

### Bridging Requirements

	AISI S240 (Standard For Structural Framing)	AISI Specification (S100)
<b>Stud Axial Compression</b>	<p><b>Load Capacity:</b> Bracing Load <math>P_{\text{Brace}}^* = 0.02 \times \text{Stud Compression Load } (P_{\text{Stud}}) \times \# \text{ of studs braced.}</math></p>	<p><b>Load Capacity:</b> Bracing Load <math>P_{\text{Brace}}^* = 0.01 \times \text{Stud Allowable Compression } (P_{a\_stud}) \times \# \text{ of studs braced.}</math></p> <p><b>Stiffness Capacity:</b> Lateral Stiffness <math>\beta_{\text{Brace}} = 4 \times \text{Stud Nominal Axial Strength} / \text{Unbraced Length}</math> (for one row of bridging). Lateral Stiffness <math>\beta_{\text{Brace}} = 6 \times \text{Stud Nominal Axial Strength} / \text{Unbraced Length}</math> (for two rows of bridging).</p>
<b>Wind</b>	<p><b>Load Capacity:</b> Twist Load <math>P_L = 1.5 \times \text{Wind Load} \times \text{Bridging Spacing} \times \text{Stud Spacing} \times m(\text{Shear Center Distance}) / \text{Stud Depth.}</math> Twist Moment <math>M_1 = P_L \times \text{Stud Depth.}</math></p>	

\* Bracing forces accumulate over the run of the wall until anchored.

Bridging Load Bearing Studs Against Torsion By Wind

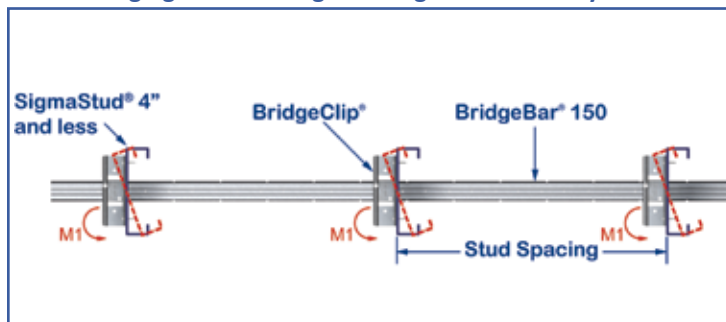

Bridging Load Bearing Studs Against Weak Axis Buckling

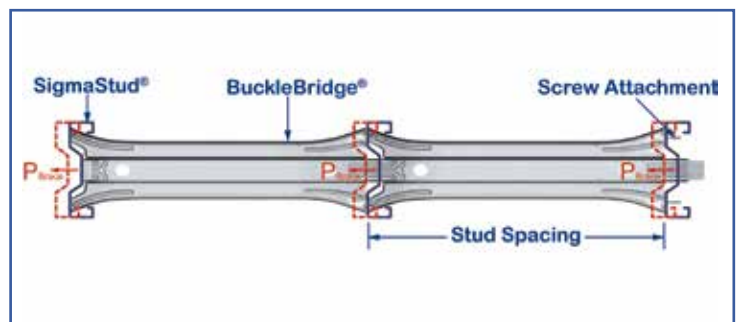
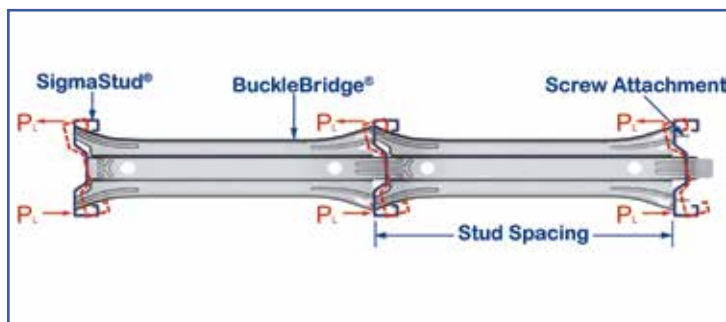
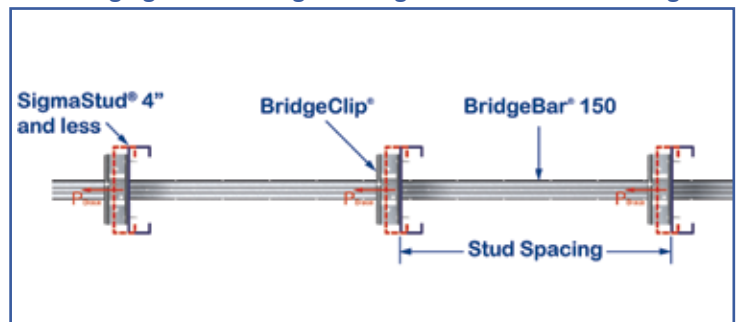

# Curtain Wall Bridging Chart

Quick Reference

The Steel Network, Inc.

www.steelnetwork.com

1-888-474-4876



**Bridging Clip Chart: Design Wind Pressure, Stud Spacing and Maximum Bridging Spacing**

Section	10 psf				20 psf							
	24" o.c.				16" o.c.				24" o.c.			
	5'	6'	7'	8'	5'	6'	7'	8'	5'	6'	7'	8'
600S162-33, 33 ksi	BC-33, 1	BC-33, 1	BC-33, 1	N/A	BC-33, 1	BC-33, 1	N/A	N/A	BC-33, 1	BC-33, 1	N/A	N/A
600S162-43, 33 ksi	BC-33, 1	BC-33, 1	BC-33, 1	BC-33, 1	BC-33, 1	BC-33, 1	BC-33, 1	N/A	BC-33, 1	BC-33, 1	N/A	N/A
600S162-54, 50 ksi	BC-33, 1	BC-33, 1	BC-33, 1	BC-33, 1	BC-33, 1	BC-33, 1	BC-33, 1	N/A	BC-33, 1	BC-33, 1	BC-33, 1	N/A
600S162-68, 50 ksi	BC-33, 1	BC-33, 1	BC-33, 1	BC-33, 1	BC-33, 1	BC-33, 1	BC-33, 1	BC-33, 1	BC-33, 1	BC-33, 1	BC-33, 1	N/A
600S162-97, 50 ksi	BC-33, 1	BC-33, 1	BC-33, 1	BC-33, 1	BC-33, 1	BC-33, 1	BC-33, 1	BC-33, 1	BC-33, 1	BC-33, 1	BC-33, 1	BC-33, 1
600S200-33, 33 ksi	BC-33, 1	BC-33, 1	BC-33, 1	BC-33, 1	BC-33, 1	BC-33, 1	BC-33, 1	N/A	BC-33, 1	BC-33, 3	N/A	N/A
600S200-43, 33 ksi	BC-33, 1	BC-33, 1	BC-33, 1	BC-33, 1	BC-33, 1	BC-33, 1	BC-33, 1	BC-33, 1	BC-33, 1	BC-33, 1	BC-33, 1	N/A
600S200-54, 50 ksi	BC-33, 1	BC-33, 1	BC-33, 1	BC-33, 1	BC-33, 1	BC-33, 1	BC-33, 1	BC-33, 1	BC-33, 1	BC-33, 1	BC-33, 1	BC-33, 1
600S200-68, 50 ksi	BC-33, 1	BC-33, 1	BC-33, 1	BC-33, 1	BC-33, 1	BC-33, 1	BC-33, 1	BC-33, 1	BC-33, 1	BC-33, 1	BC-33, 1	BC-33, 1
600S200-97, 50 ksi	BC-33, 1	BC-33, 1	BC-33, 1	BC-33, 1	BC-33, 1	BC-33, 1	BC-33, 1	BC-33, 1	BC-33, 1	BC-33, 1	BC-33, 1	BC-33, 1
800S162-33, 33 ksi	BC-33, 1	BC-33, 1	BC-33, 1	BC-33, 1	BC-33, 1	BC-33, 1	BC-33, 1	N/A	BC-33, 1	BC-33, 1	BC-43, 1	N/A
800S162-43, 33 ksi	BC-33, 1	BC-33, 1	BC-33, 1	BC-33, 1	BC-33, 1	BC-33, 1	BC-33, 1	BC-33, 1	BC-33, 1	BC-33, 1	BC-33, 1	N/A
800S162-54, 50 ksi	BC-33, 1	BC-33, 1	BC-33, 1	BC-33, 1	BC-33, 1	BC-33, 1	BC-33, 1	BC-33, 1	BC-33, 1	BC-33, 1	BC-33, 1	N/A
800S162-68, 50 ksi	BC800	BC800	BC800	BC800	BC800	BC800	BC800	BC800	BC800	BC800	BC800	BC800
800S162-97, 50 ksi	BC800	BC800	BC800	BC800	BC800	BC800	BC800	BC800	BC800	BC800	BC800	BC800
800S200-33, 33 ksi	BC-33, 1	BC-33, 1	BC-33, 1	BC-33, 1	BC-33, 1	BC-33, 1	BC-33, 1	BC-43, 1	BC-43, 1	BC-43, 1	BC-33, 3	N/A
800S200-43, 33 ksi	BC-33, 1	BC-33, 1	BC-33, 1	BC-33, 1	BC-33, 1	BC-33, 1	BC-33, 1	BC-33, 1	BC-33, 1	BC-33, 1	BC-43, 1	BC-33, 3
800S200-54, 50 ksi	BC-33, 1	BC-33, 1	BC-33, 1	BC-33, 1	BC-33, 1	BC-33, 1	BC-33, 1	BC-33, 1	BC-33, 1	BC-33, 1	BC-33, 1	BC-43, 1
800S200-68, 50 ksi	BC800	BC800	BC800	BC800	BC800	BC800	BC800	BC800	BC800	BC800	BC800	BC800
800S200-97, 50 ksi	BC800	BC800	BC800	BC800	BC800	BC800	BC800	BC800	BC800	BC800	BC800	BC800

**Bridging Clip Chart: Design Wind Pressure, Stud Spacing and Maximum Bridging Spacing (continued)**

Section	25 psf							
	16" o.c.				24" o.c.			
	5'	6'	7'	8'	5'	6'	7'	8'
600S162-33, 33 ksi	BC-33, 1	BC-33, 1	N/A	N/A	BC-33, 1	N/A	N/A	N/A
600S162-43, 33 ksi	BC-33, 1	BC-33, 1	BC-33, 1	N/A	BC-33, 1	BC-33, 1	N/A	N/A
600S162-54, 50 ksi	BC-33, 1	BC-33, 1	BC-33, 1	N/A	BC-33, 1	BC-33, 1	N/A	N/A
600S162-68, 50 ksi	BC-33, 1	BC-33, 1	BC-33, 1	N/A	BC-33, 1	BC-33, 1	BC-33, 1	N/A
600S162-97, 50 ksi	BC-33, 1	BC-33, 1	BC-33, 1	BC-33, 1	BC-33, 1	BC-33, 1	BC-33, 1	N/A
600S200-33, 33 ksi	BC-33, 1	BC-33, 1	BC-33, 1	N/A	BC-33, 3	N/A	N/A	N/A
600S200-43, 33 ksi	BC-33, 1	BC-33, 1	BC-33, 1	BC-33, 1	BC-33, 1	BC-33, 1	N/A	N/A
600S200-54, 50 ksi	BC-33, 1	BC-33, 1	BC-33, 1	BC-33, 1	BC-33, 1	BC-33, 1	BC-33, 3	N/A
600S200-68, 50 ksi	BC-33, 1	BC-33, 1	BC-33, 1	BC-33, 1	BC-33, 1	BC-33, 1	BC-33, 1	N/A
600S200-97, 50 ksi	BC-33, 1	BC-33, 1	BC-33, 1	BC-33, 1	BC-33, 1	BC-33, 1	BC-33, 1	BC-33, 1
800S162-33, 33 ksi	BC-33, 1	BC-33, 1	BC-33, 1	N/A	BC-33, 1	BC-43, 1	N/A	N/A
800S162-43, 33 ksi	BC-33, 1	BC-33, 1	BC-33, 1	N/A	BC-33, 1	BC-33, 1	N/A	N/A
800S162-54, 50 ksi	BC-33, 1	BC-33, 1	BC-33, 1	BC-33, 1	BC-33, 1	BC-33, 1	BC-33, 1	N/A
800S162-68, 50 ksi	BC800	BC800	BC800	BC800	BC800	BC800	BC800	N/A
800S162-97, 50 ksi	BC800	BC800	BC800	BC800	BC800	BC800	BC800	BC800
800S200-33, 33 ksi	BC-33, 1	BC-43, 1	BC-43, 1	BC-33, 3	BC-43, 1	BC-33, 3	N/A	N/A
800S200-43, 33 ksi	BC-33, 1	BC-33, 1	BC-33, 1	BC-43, 1	BC-43, 1	BC-43, 1	BC-33, 3	N/A
800S200-54, 50 ksi	BC-33, 1	BC-33, 1	BC-33, 1	BC-33, 1	BC-33, 1	BC-43, 1	BC-43, 1	BC-33, 3
800S200-68, 50 ksi	BC800	BC800	BC800	BC800	BC800	BC800	BC800	BC800
800S200-97, 50 ksi	BC800	BC800	BC800	BC800	BC800	BC800	BC800	BC800

**\*\*Important table notes on page 66.**

Bridging Clip Chart: Design Wind Pressure, Stud Spacing and Maximum Bridging Spacing												
Section	30 psf								40 psf			
	16" o.c.				24" o.c.				16" o.c.			
	5'	6'	7'	8'	5'	6'	7'	8'	5'	6'	7'	8'
600S162-33, 33 ksi	BC-33, 1	BC-33, 1	N/A	N/A	BC-33, 1	N/A	N/A	N/A	BC-33, 1	N/A	N/A	N/A
600S162-43, 33 ksi	BC-33, 1	BC-33, 1	N/A	N/A	BC-33, 1	N/A	N/A	N/A	BC-33, 1	BC-33, 1	N/A	N/A
600S162-54, 50 ksi	BC-33, 1	BC-33, 1	BC-33, 1	N/A	BC-33, 1	BC-33, 1	N/A	N/A	BC-33, 1	BC-33, 1	N/A	N/A
600S162-68, 50 ksi	BC-33, 1	BC-33, 1	BC-33, 1	N/A	BC-33, 1	BC-33, 1	N/A	N/A	BC-33, 1	BC-33, 1	BC-33, 1	N/A
600S162-97, 50 ksi	BC-33, 1	BC-33, 1	BC-33, 1	BC-33, 1	BC-33, 1	BC-33, 1	N/A	N/A	BC-33, 1	BC-33, 1	BC-33, 1	N/A
600S200-33, 33 ksi	BC-33, 1	BC-33, 3	N/A	N/A	BC-43, 3	N/A	N/A	N/A	BC-33, 3	N/A	N/A	N/A
600S200-43, 33 ksi	BC-33, 1	BC-33, 1	BC-33, 1	N/A	BC-33, 1	N/A	N/A	N/A	BC-33, 1	BC-43, 1	N/A	N/A
600S200-54, 50 ksi	BC-33, 1	BC-33, 1	BC-33, 1	BC-33, 1	BC-33, 1	BC-43, 1	N/A	N/A	BC-33, 1	BC-33, 1	BC-43, 1	N/A
600S200-68, 50 ksi	BC-33, 1	BC-33, 1	BC-33, 1	BC-33, 1	BC-33, 1	BC-33, 1	N/A	N/A	BC-33, 1	BC-33, 1	BC-33, 1	N/A
600S200-97, 50 ksi	BC-33, 1	BC-33, 1	BC-33, 1	BC-33, 1	BC-33, 1	BC-33, 1	N/A	N/A	BC-33, 1	BC-33, 1	BC-33, 1	N/A
800S162-33, 33 ksi	BC-33, 1	BC-33, 1	N/A	N/A	BC-43, 1	N/A	N/A	N/A	BC-43, 1	N/A	N/A	N/A
800S162-43, 33 ksi	BC-33, 1	BC-33, 1	BC-33, 1	N/A	BC-33, 1	BC-43, 1	N/A	N/A	BC-33, 1	BC-33, 1	N/A	N/A
800S162-54, 50 ksi	BC-33, 1	BC-33, 1	BC-33, 1	N/A	BC-33, 1	BC-33, 1	N/A	N/A	BC-33, 1	BC-33, 1	BC-33, 1	N/A
800S162-68, 50 ksi	BC800	BC800	BC800	BC800	BC800	BC800	BC800	N/A	BC800	BC800	BC800	N/A
800S162-97, 50 ksi	BC800	BC800	BC800	BC800	BC800	BC800	BC800	BC800	BC800	BC800	BC800	BC800
800S200-33, 33 ksi	BC-43, 1	BC-43, 1	BC-33, 3	N/A	BC-33, 3	N/A	N/A	N/A	BC-33, 3	BC-33, 3	N/A	N/A
800S200-43, 33 ksi	BC-33, 1	BC-33, 1	BC-43, 1	BC-33, 3	BC-43, 1	BC-33, 3	BC-43, 3	N/A	BC-43, 1	BC-33, 3	BC-33, 3	N/A
800S200-54, 50 ksi	BC-33, 1	BC-33, 1	BC-33, 1	BC-43, 1	BC-43, 1	BC-43, 1	BC-33, 3	N/A	BC-33, 1	BC-43, 1	BC-43, 1	BC-33, 3
800S200-68, 50 ksi	BC800	BC800	BC800	BC800	BC800	BC800	BC800	N/A	BC800	BC800	BC800	BC800
800S200-97, 50 ksi	BC800	BC800	BC800	BC800	BC800	BC800	BC800	N/A	BC800	BC800	BC800	BC800

Bridging Clip Chart: Design Wind Pressure, Stud Spacing and Maximum Bridging Spacing (continued)								
Section	50 psf							
	24" o.c.				16" o.c.			
	5'	6'	7'	8'	5'	6'	7'	7'
600S162-33, 33 ksi	N/A	N/A	N/A	N/A	N/A	N/A	N/A	N/A
600S162-43, 33 ksi	BC-33, 1	N/A	N/A	N/A	BC-33, 1	N/A	N/A	N/A
600S162-54, 50 ksi	BC-33, 1	N/A	N/A	N/A	BC-33, 1	BC-33, 1	N/A	N/A
600S162-68, 50 ksi	BC-33, 1	N/A	N/A	N/A	BC-33, 1	BC-33, 1	N/A	N/A
600S162-97, 50 ksi	BC-33, 1	N/A	N/A	N/A	BC-33, 1	BC-33, 1	N/A	N/A
600S200-33, 33 ksi	N/A	N/A	N/A	N/A	N/A	N/A	N/A	N/A
600S200-43, 33 ksi	N/A	N/A	N/A	N/A	BC-43, 1	N/A	N/A	N/A
600S200-54, 50 ksi	N/A	N/A	N/A	N/A	BC-33, 3	N/A	N/A	N/A
600S200-68, 50 ksi	N/A	N/A	N/A	N/A	BC-33, 1	N/A	N/A	N/A
600S200-97, 50 ksi	BC-33, 1	N/A	N/A	N/A	BC-33, 1	N/A	N/A	N/A
800S162-33, 33 ksi	N/A	N/A	N/A	N/A	N/A	N/A	N/A	N/A
800S162-43, 33 ksi	BC-43, 1	N/A	N/A	N/A	BC-43, 1	BC-43, 1	N/A	N/A
800S162-54, 50 ksi	BC-33, 1	BC-43, 1	N/A	N/A	BC-33, 1	BC-33, 1	N/A	N/A
800S162-68, 50 ksi	BC800	BC800	N/A	N/A	BC800	BC800	BC800	N/A
800S162-97, 50 ksi	BC800	BC800	BC800	N/A	BC800	BC800	BC800	N/A
800S200-33, 33 ksi	N/A	N/A	N/A	N/A	N/A	N/A	N/A	N/A
800S200-43, 33 ksi	BC-43, 3	N/A	N/A	N/A	BC-33, 3	BC-43, 3	N/A	N/A
800S200-54, 50 ksi	BC-33, 3	N/A	N/A	N/A	BC-43, 1	BC-33, 3	N/A	N/A
800S200-68, 50 ksi	BC800	N/A	N/A	N/A	BC800	BC800	N/A	N/A
800S200-97, 50 ksi	BC800	N/A	N/A	N/A	BC800	BC800	N/A	N/A

**\*\*Important table notes on page 66.**

# Curtain Wall Bridging Chart

Quick Reference



BuckleBridge® Bridging Chart: Design Wind Pressure and Maximum Bridging Spacing																				
Section	20 psf				25 psf				30 psf				40 psf				50 psf			
	5'	6'	7'	8'	5'	6'	7'	8'	5'	6'	7'	8'	5'	6'	7'	8'	5'	6'	7'	8'
600S162-33, 33 ksi	BKB	BKB	N/A	N/A	BKB	BKB	N/A	N/A	BKB	BKB	N/A	N/A	BKB	N/A	N/A	N/A	N/A	N/A	N/A	N/A
600S162-43, 33 ksi	BKB	BKB	BKB	N/A	BKB	BKB	N/A	N/A	BKB	BKB	N/A	N/A	BKB	BKB	N/A	N/A	BKB	N/A	N/A	N/A
600S162-54, 50 ksi	BKB	BKB	BKB	N/A	BKB	BKB	BKB	N/A	BKB	BKB	BKB	N/A	BKB	BKB	N/A	N/A	BKB	BKB	N/A	N/A
600S162-68, 50 ksi	BKB	BKB	BKB	BKB	BKB	BKB	BKB	N/A	BKB	BKB	BKB	N/A	BKB	BKB	BKB	N/A	BKB	BKB	N/A	N/A
600S162-97, 50 ksi	BKB	BKB	BKB	BKB	BKB	BKB	BKB	BKB	BKB	BKB	BKB	BKB	BKB	BKB	BKB	N/A	BKB	BKB	BKB	N/A
600S200-33, 33 ksi	BKB	BKB	BKB	N/A	BKB	BKB	BKB	N/A	BKB	BKB	N/A	N/A	BKB	N/A	N/A	N/A	N/A	N/A	N/A	N/A
600S200-43, 33 ksi	BKB	BKB	BKB	BKB	BKB	BKB	BKB	N/A	BKB	BKB	BKB	N/A	BKB	BKB	N/A	N/A	BKB	BKB	N/A	N/A
600S200-54, 50 ksi	BKB	BKB	BKB	BKB	BKB	BKB	BKB	BKB	BKB	BKB	BKB	BKB	BKB	BKB	BKB	N/A	BKB	BKB	BKB	N/A
600S200-68, 50 ksi	BKB	BKB	BKB	BKB	BKB	BKB	BKB	BKB	BKB	BKB	BKB	BKB	BKB	BKB	BKB	BKB	BKB	BKB	BKB	N/A
600S200-97, 50 ksi	BKB	BKB	BKB	BKB	BKB	BKB	BKB	BKB	BKB	BKB	BKB	BKB	BKB	BKB	BKB	BKB	BKB	BKB	BKB	BKB
800S162-33, 33 ksi	BKB	BKB	BKB	N/A	BKB	BKB	N/A	N/A	BKB	BKB	N/A	N/A	BKB	N/A	N/A	N/A	N/A	N/A	N/A	N/A
800S162-43, 33 ksi	BKB	BKB	BKB	N/A	BKB	BKB	BKB	N/A	BKB	BKB	BKB	N/A	BKB	BKB	N/A	N/A	BKB	BKB	N/A	N/A
800S162-54, 50 ksi	BKB	BKB	BKB	BKB	BKB	BKB	BKB	BKB	BKB	BKB	BKB	N/A	BKB	BKB	BKB	N/A	BKB	BKB	N/A	N/A
800S162-68, 50 ksi	BKB	BKB	BKB	BKB	BKB	BKB	BKB	BKB	BKB	BKB	BKB	BKB	BKB	BKB	BKB	N/A	BKB	BKB	BKB	N/A
800S162-97, 50 ksi	BKB	BKB	BKB	BKB	BKB	BKB	BKB	BKB	BKB	BKB	BKB	BKB	BKB	BKB	BKB	BKB	BKB	BKB	BKB	N/A
800S200-33, 33 ksi	BKB	BKB	BKB	BKB	BKB	BKB	BKB	N/A	BKB	BKB	BKB	N/A	BKB	BKB	N/A	N/A	N/A	N/A	N/A	N/A
800S200-43, 33 ksi	BKB	BKB	BKB	BKB	BKB	BKB	BKB	BKB	BKB	BKB	BKB	BKB	BKB	BKB	BKB	N/A	BKB	BKB	BKB	N/A
800S200-54, 50 ksi	BKB	BKB	BKB	BKB	BKB	BKB	BKB	BKB	BKB	BKB	BKB	BKB	BKB	BKB	BKB	BKB	BKB	BKB	BKB	N/A
800S200-68, 50 ksi	BKB	BKB	BKB	BKB	BKB	BKB	BKB	BKB	BKB	BKB	BKB	BKB	BKB	BKB	BKB	BKB	BKB	BKB	BKB	BKB
800S200-97, 50 ksi	BKB	BKB	BKB	BKB	BKB	BKB	BKB	BKB	BKB	BKB	BKB	BKB	BKB	BKB	BKB	BKB	BKB	BKB	BKB	BKB

**\*\*Important table notes on next page.**

**Notes:**

1. Listed wind pressures represent calculated design wind pressure (0.6W based on 2021 IBC).
2. Allowable pressures are limited by published test data allowable torsional moments for bridging elements.
3. Torsional moment acting on bridging elements is calculated as:  
 **$M = 1.5 \times \text{Wind Pressure} \times \text{Bridging Spacing} \times \text{Stud Spacing} \times m$  (distance from stud web to shear center).**
4. Wall height is assumed twice the bridging spacing.
5. BuckleBridge® stud spacing is fixed at 16".
6. 20 psf and higher wind pressures have been multiplied by 0.7 for deflection determination, in accordance with footnote "f" of IBC table 1604.3. The 10 psf pressure has not been reduced for deflection checks.
7. Stud design is limited by its flexural strength calculated with torsional bracing assumed at the bridging spacing and  $k\phi = 0$  and deflection limit of  $L/360$ .
8. 'N/A' indicates stud and/or bridging cannot be designed. Reduced stud spacing or bridging spacing is required.

**Nomenclature:**

- BC-33, 1** - BridgeClip® BC-33 with (1) #10 screw fastener into bridging member.  
**BC-33, 3** - BridgeClip® BC-33 with (1) #10 screw fastener into bridging member and (2) #10 screw fasteners into the web of the stud.  
**BC-43, 1** - BridgeClip® BC-43 with (1) #10 screw fastener into bridging member.  
**BC-43, 3** - BridgeClip® BC-43 with (1) #10 screw fastener into bridging member and (2) #10 screw fasteners into the web of the stud.  
**BC600** - BridgeClip® BC600 with (2) #10 screw fasteners into bridging member and (2) #10 screw fasteners into the web of the stud.  
**BC800** - BridgeClip® BC800 with (2) #10 screw fasteners into bridging member and (2) #10 screw fasteners into the web of the stud.  
**BKB** - BuckleBridge® with (1) #10 screw on alternate sides of the BuckleBridge at 3rd stud (48" o.c.). Use (2) #10 screws at end of wall run.

# Wall Bridging Anchorage

Quick Reference

The Steel Network, Inc.

[www.steelnetwork.com](http://www.steelnetwork.com)

1-888-474-4876



## Anchorage of Lateral Bracing (Bridging) Forces

**Load Bearing Wall Bridging Row Anchored to Jamb Stud or End Column - Track Bracing Utilizing BridgeBar® 150 with BC600/BC800**

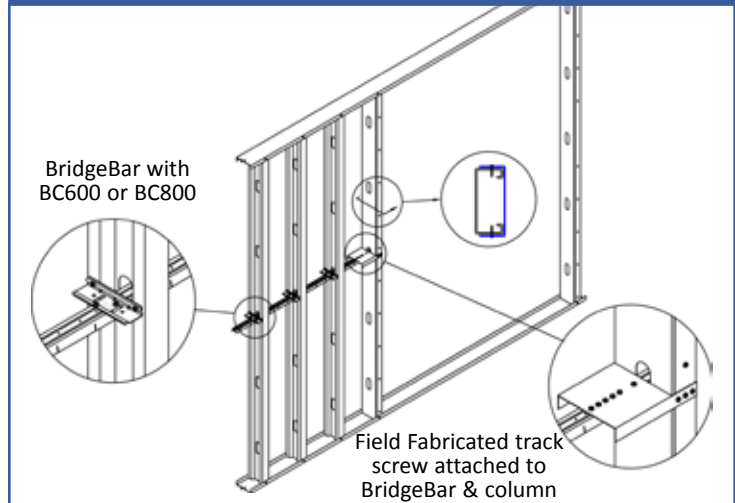

**Load Bearing Wall Bridging Row Anchored to Jamb Stud or End Column - Track Bracing Utilizing BuckleBridge®**

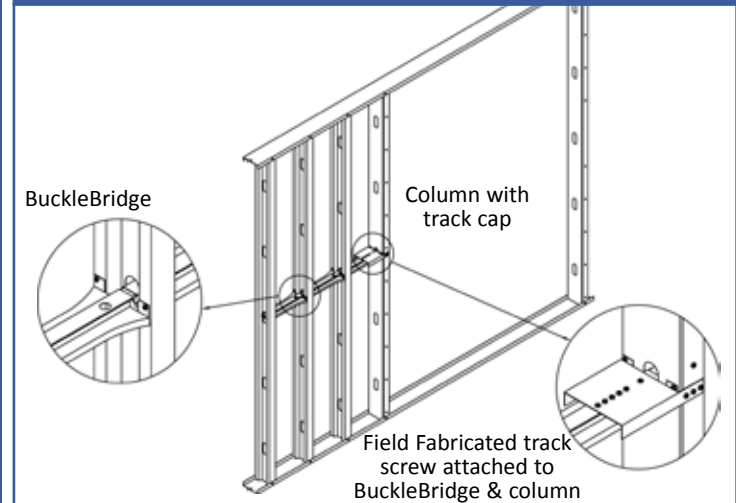

**Load Bearing Wall Bridging Row Anchored to Floor System Through Cross Bracing - Utilizing BuckleBridge**

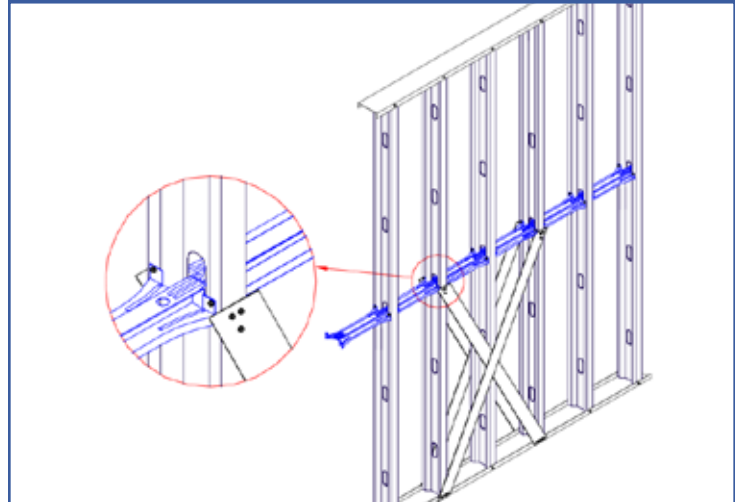

**Load Bearing Wall Bridging Row Anchored to Floor System Through Cross Bracing - Utilizing BridgeBar 150 with BC600/BC800**

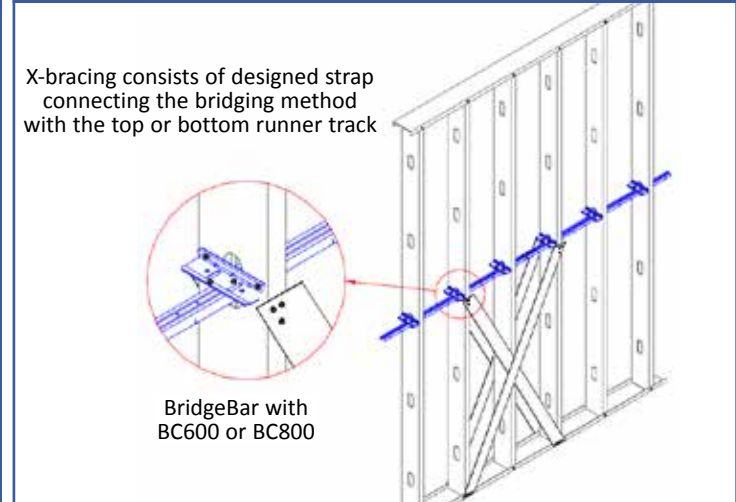

**Load Bearing Wall Bridging Row Anchored to Jamb Stud or End Column - Flat Strap Bracing w/ Blocking**

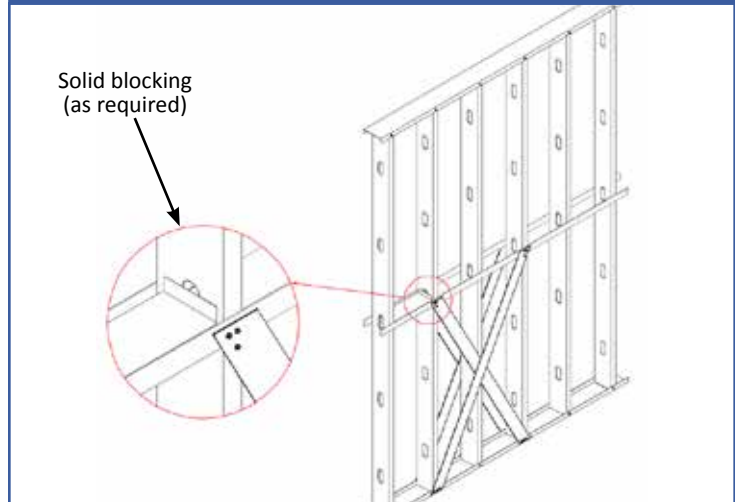

**Load Bearing Wall Bridging Row Anchored to Jamb Stud or End Column - Flat Strap Bracing w/ Blocking**

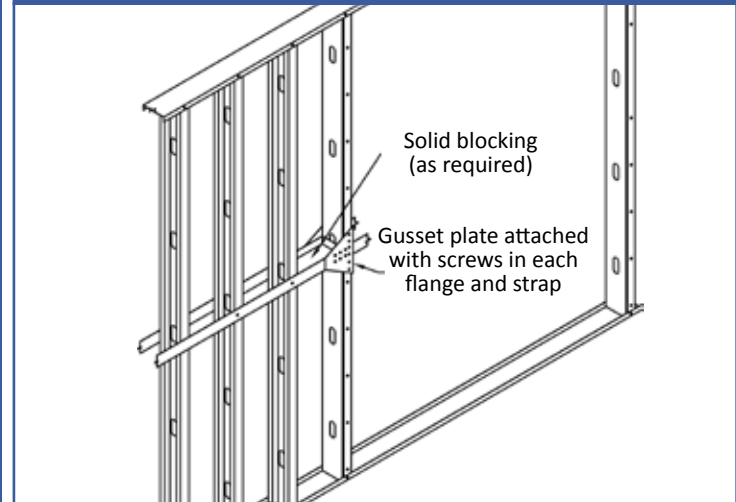

# BridgeClip®

Secures Channel to Stud

### Material Composition

**BC-33:** ASTM A1003/A1003M Structural Grade 50 (340) Type H, ST50H (ST340H): 50ksi (340MPa) minimum yield strength, 65ksi (450MPa) minimum tensile strength, 33mil minimum thickness (20 gauge, 0.0346" design thickness) with ASTM A653/A653M G90 (Z275) hot dipped galvanized coating.

**BC-43, BC600 & BC800:** ASTM A1003/A1003M Structural Grade 50 (340) Type H, ST50H (ST340H): 50ksi (340MPa) minimum yield strength, 65ksi (450MPa) minimum tensile strength, 43mil minimum thickness (18 gauge, 0.0451" design thickness) with ASTM A653/A653M G90 (Z275) hot dipped galvanized coating.

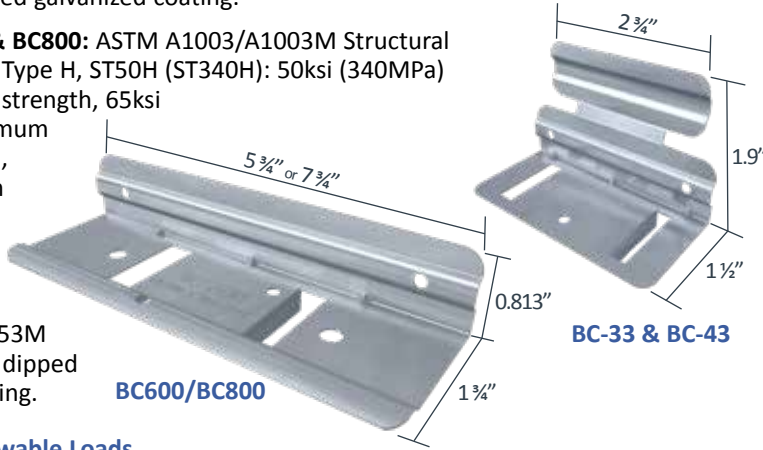

### BridgeClip Allowable Loads

BridgeClip	Stud Depth	Stud Thickness (mils) (ga)	Axially Loaded Stud, Allowable Brace Strength F1 (lbs)	Laterally Loaded Stud, Allowable Torsional Moment M1 (in.lbs)
BC-33, 1	3.625/4	33 (20)	75	132
		43 (18)		143
		54 (16)		156
BC-43, 1	3.625/4	33 (20)	112	168
		43 (18)		179
		54 (16)		192
BC-33, 3	3.625/4	33 (20)	360	192
		43 (18)		221
		54 (16)		252
BC-43, 3	3.625/4	33 (20)	433	240
		43 (18)		297
		54 (16)		360
BC-33, 1	6	33 (20)	75	192
		43 (18)		252
		54 (16)		264
		68 (14)		307
BC-43, 1	6	33 (20)	112	396
		43 (18)		240
		54 (16)		372
		68 (14)		324
BC-33, 3	6	33 (20)	360	468
		43 (18)		228
		54 (16)		254
		68 (14)		288
BC-43, 3	6	33 (20)	433	324
		43 (18)		408
		54 (16)		480
		68 (14)		324
BC600	6	33 (20)	360	684
		43 (18)		792
		54 (16)		864
		68 (14)		887
BC-33, 1	8	33 (20)	75	936
		43 (18)		144
		54 (16)		178
BC-43, 1	8	33 (20)	112	216
		43 (18)		192
		54 (16)		232
BC-33, 3	8	33 (20)	360	276
		43 (18)		240
		54 (16)		280
BC-43, 3	8	33 (20)	433	324
		43 (18)		288
		54 (16)		339
BC800	8	33 (20)	360	396
		43 (18)		756
		54 (16)		790
		68 (14)		828
		97 (12)		851
				900

Load Direction

US Patent #5,904,023

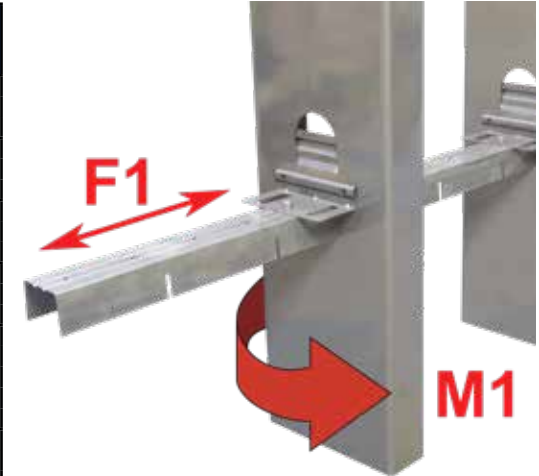

### Table Notes:

- Listed ASD allowable loads are based on ultimate test data divided by a factor of safety.
- Listed ASD allowable loads are limited by screw shear or pullout at stud web.

Table Nomenclature	Clip	Qty # 10 Screws into Bridging	Qty # 10 Screws into Stud
BC-33, 1	BC-33	1	0
BC-33, 3	BC-33	1	2
BC-43, 1	BC-43	1	0
BC-43, 3	BC-43	1	2
BC600	BC600	2	2
BC800	BC800	2	2

### Nomenclature

BridgeClip is designated by the type BC.

# BridgeBar®

Bridging Channel

### Material Composition

**BB75:** ASTM A1003/A1003M Structural Grade 33 (230) Type H, ST33H (ST230H): 33ksi (230MPa) minimum yield strength, 45ksi (310MPa) minimum tensile strength, 28mil minimum thickness (22 gauge, 0.0295" design thickness) with ASTM A653/A653M G60 (Z180) hot dipped galvanized coating.

**BB150:** ASTM A1003/A1003M Structural Grade 50 (340) Type H, ST50H (ST340H): 50ksi (340MPa) minimum yield strength, 65ksi (450MPa) minimum tensile strength, 33mil minimum thickness (20 gauge, 0.0346" design thickness) with ASTM A653/A653M G90 (Z275) hot dipped galvanized coating.

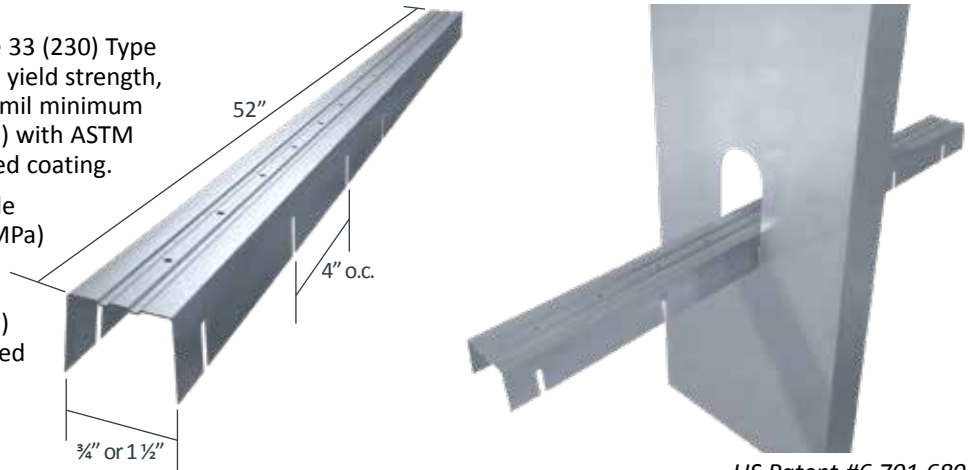

US Patent #6,701,689

### Material Analysis

Section	Minimum Thickness (in)	Design Thickness (in)	Yield Strength (ksi)	Effective Section Properties <sup>(1)</sup>						Effective Section Properties and Allowable Loads <sup>(2), (3), (4)</sup>							
				Area		S <sub>x</sub>		I <sub>y</sub>		S <sub>xe</sub>	M <sub>a</sub> (X-axis)	12" o.c.		16" o.c.		24" o.c.	
				(in <sup>2</sup> )	(in <sup>4</sup> )	(in <sup>3</sup> )	(in)	(in <sup>4</sup> )	(in)			(in <sup>3</sup> )	(in-kips (ft-lb))	(in <sup>2</sup> )	(lbs)	(in <sup>2</sup> )	(lbs)
BB75	0.0280	0.0295	33	0.031	0.0021	0.006	0.261	0.0002	0.073	0.006	0.11 (9.3)	N/A	N/A	N/A	N/A	N/A	N/A
BB150	0.0329	0.0346	50	0.068	0.0174	0.023	0.506	0.0007	0.104	0.023	0.69 (57.9)	0.079	1,459	0.081	1,172	0.081	566

### Notes:

- Use BridgeClip® for a quick & easy method of securing BridgeBar to stud when required
- Resists compressive loads through the plane of the wall
- Use through 3/4" and 1 1/2" stud punchouts.

<sup>1</sup> Gross section properties are calculated based on the minimum dimensions of the cross section.

<sup>2</sup> Effective section properties and allowable loads for BridgeBar are calculated based on AISI S100-2016 Specification.

<sup>3</sup> Effective section modulus (S<sub>xe</sub>) is calculated based on the minimum dimensions of the cross section.

<sup>4</sup> Effective area (A<sub>e</sub>) and allowable axial load (P<sub>a</sub>) are calculated based on the average dimensions of the cross section.

### Securing Bar to Stud

When loads require attachment of BridgeBar to stud, consider the screw shear allowables below for connection of BridgeClip to stud and BridgeBar.

Section	Design Thickness (in)	Yield Strength (ksi)	Allowable Shear/Screw	
			#8 Screw (lbs)	#10 Screw (lbs)
BB150	0.0346	50	237	255

### Nomenclature

BridgeBar is available in 3/4" and 1 1/2" widths. Designations are BB75 and BB150.

**Example:** Stud with 3/4" knockout  
**Designate:** BB75

### Cross Sections

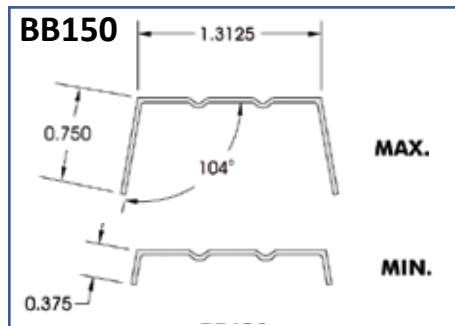
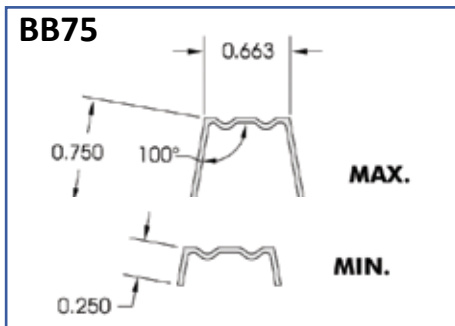

### Load Direction

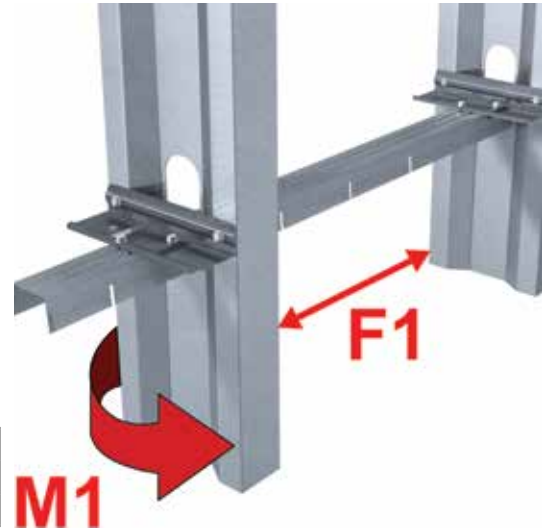

### Lap Joint

BridgeBar's 52" length allows for a 4" overlap at joints. Simply fit one end over the other and line up the guide holes for quick & easy placement of screw(s). Joint locations maintain stud spacing as designed through length of the wall system.



# BuckleBridge®

Bridging System

The Steel Network, Inc.

www.steelnetwork.com

1-888-474-4876



### Material Composition

ASTM A1003/A1003M Structural Grade 50 (340) Type H, ST50H (ST340H): 50ksi (340MPa) minimum yield strength, 65ksi (450MPa) minimum tensile strength, 33mil minimum thickness (20 gauge, 0.0346" design thickness) with ASTM A653/A653M G90 (Z275) hot dipped galvanized coating.

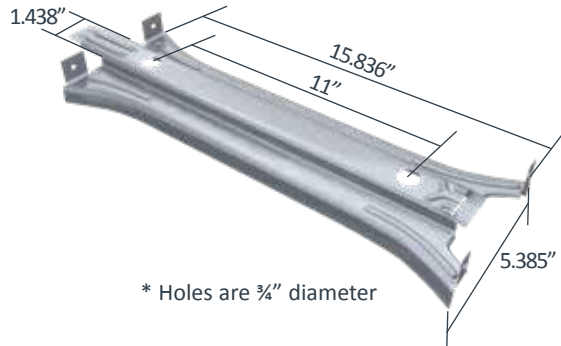

US Patents #7,596,921, #7,836,657 & #8,205,402

Load Direction

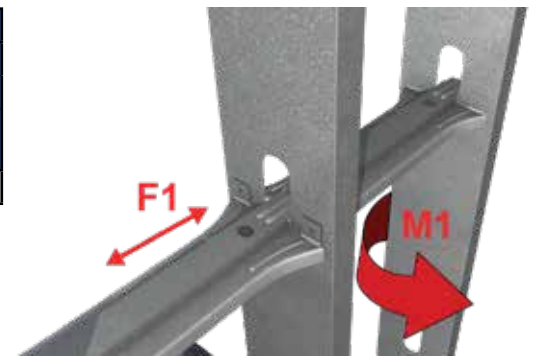

### BuckleBridge Allowable Loads

BuckleBridge® Allowable Loads						
Studs 16" o.c.	Axially Loaded Studs				Laterally Loaded Studs	
	Compression Brace		Tension Brace		6" Studs	8" Studs
	F1 (lbs)	Stiffness (lbs/in)	F1 (lbs)	Stiffness (lbs/in)	M1 (in-lb)	M1 (in-lb)
	2,400	31,000	440	2,560	1,290	967

### Nomenclature

BuckleBridge comes in one size and is designated *BuckleBridge*®. It is used with 16" o.c. member spacing.

### Example Details



When using BuckleBridge in curtain walls with standard "cee" studs, one screw is only needed every 3rd stud.\*



BuckleBridge used in load bearing walls with TSN's SigmaStud



BuckleBridge works just as easily with back-to-back studs.

### Notes:

- Resists weak axis buckling and torsional rotation of members.
  - Spaces studs automatically at 16" o.c. Suitable for 6" & 8" walls.
  - Elongated tabs in one end of BuckleBridge lock into a slot at the other end through the stud knockout.
- \* Use (1) #10 screw on alternate sides of the BuckleBridge at 3rd stud (48" o.c.) Use (2) #10 screws at end of wall run.

# StiffClip® LB

Spandrel Wall Bypass



### Material Composition

ASTM A1003/A1003M Structural Grade 50 (340) Type H, ST50H (ST340H): 50ksi (340MPa) minimum yield strength, 65ksi (450MPa) minimum tensile strength, 68mil minimum thickness (14 gauge, 0.0713" design thickness) with ASTM A653/A653M G90 (Z275) hot dipped galvanized coating.

The attachment of StiffClip LB to the primary structure may be made with PAFs, screw/bolt anchors or weld and is dependent upon the base material (steel or concrete) and the design configuration.

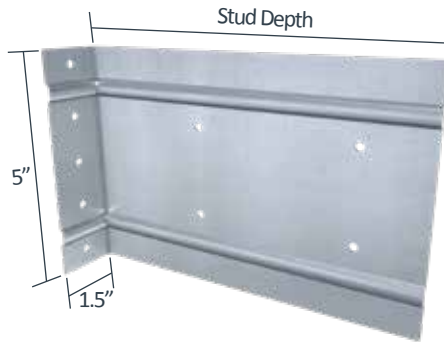

### StiffClip LB Allowable Loads

StiffClip® LB, Recommended Allowable Load (lbs):													
Screw Patterns with #12 Screws	F1 Load Direction												
	LB362			LB600			LB800 (Standard 2" Offset)			LB1000 (Standard 2" Offset) LB1200 (Standard 2" Offset)		LB1000 (4" Offset)	
	Pattern 1: 2 Screws	Pattern 2: 3 Screws	Pattern 3: 4 Screws	Pattern 1: 2 Screws	Pattern 2: 3 Screws	Pattern 3: 4 Screws	Pattern 1: 2 Screws	Pattern 2: 3 Screws	Pattern 3: 4 Screws	Pattern 9: 2 Screws	Pattern 10: 3 Screws	Pattern 11: 4 Screws	Pattern 12: 4 Screws
33mil (20ga), 33ksi Stud	376	190	190	95	190	190	95	190	190	95	190	190	190
33mil (20ga), 50ksi Stud	544	276	276	138	276	276	138	276	276	138	276	276	276
43mil (18ga), 33ksi Stud	560	248	248	124	248	248	124	248	248	124	248	248	248
43mil (18ga), 50ksi Stud	810	358	358	179	358	358	179	322	322	179	358	358	358
54mil (16ga), 33ksi Stud	788	312	312	156	312	312	156	312	312	156	312	312	312
54mil (16ga), 50ksi Stud	1,138	450	450	225	450	450	225	322	322	225	450	450	450
68mil (14ga), 50ksi Stud	1,434	568	568	284	568	568	284	322	322	284	532	532	532
97mil (12ga), 50ksi Stud	1,434	741	741	405	768	768	322	322	322	405	532	532	532
<b>Maximum Allowable Clip Load</b>	<b>741</b>			<b>768</b>			<b>322</b>			<b>532</b>		<b>532</b>	

StiffClip® LB, Recommended Allowable Load (lbs):						
Screw Patterns with #12 Screws	F2 Load Direction					
	LB362, LB600, and LB800			LB1000 (Standard 2" & 4" Offset)   LB1200 (Standard 2" Offset)		
	Pattern 1: 2 Screws	Pattern 2: 3 Screws	Pattern 3: 4 Screws	Pattern 9: 2 Screws	Pattern 10: 3 Screws	Pattern 11: 4 Screws
33mil (20ga), 33ksi Stud	376	411	752	376	549	752
33mil (20ga), 50ksi Stud	544	594	1,088	544	794	1,062
43mil (18ga), 33ksi Stud	560	612	1,120	560	818	1,062
43mil (18ga), 50ksi Stud	810	885	1,620	810	1,062	1,062
54mil (16ga), 33ksi Stud	788	860	1,576	788	1,062	1,062
54mil (16ga), 50ksi Stud	1,138	1,243	1,954	1,062	1,062	1,062
68mil (14ga), 50ksi Stud	1,434	1,566	1,954	1,062	1,062	1,062
97mil (12ga), 50ksi Stud	1,434	1,566	1,954	1,062	1,062	1,062
<b>Maximum Allowable Clip Load</b>	<b>1,954</b>			<b>1,062</b>		

StiffClip® LB, Recommended Allowable Load (lbs):											
Screw Patterns with #12 Screws	F3 Load Direction										
	LB362			LB600			LB800 (Standard 2" Offset)				
	Pattern 1: 2 Screws	Pattern 2: 3 Screws	Pattern 3: 4 Screws	Pattern 1: 2 Screws	Pattern 2: 3 Screws	Pattern 3: 4 Screws	Pattern 1: 2 Screws	Pattern 2: 3 Screws	Pattern 3: 4 Screws	Pattern 4: 6 Screws	Pattern 5: 10 Screws
33mil (20ga), 33ksi Stud	235	340	468	216	301	431	186	248	371	534	793
33mil (20ga), 50ksi Stud	340	492	677	313	435	623	269	359	537	772	1,148
43mil (18ga), 33ksi Stud	350	507	697	322	448	641	277	370	553	795	1,182
43mil (18ga), 50ksi Stud	506	733	1,008	466	648	927	401	535	800	1,150	1,709
54mil (16ga), 33ksi Stud	493	713	981	453	630	902	390	520	778	1,119	1,663
54mil (16ga), 50ksi Stud	711	1,030	1,417	654	910	1,303	563	751	1,123	1,616	2,401
68mil (14ga), 50ksi Stud	896	1,298	1,785	825	1,147	1,642	710	946	1,416	2,036	3,026
97mil (12ga), 50ksi Stud	896	1,298	1,785	825	1,147	1,642	710	946	1,416	2,036	3,026
<b>Maximum Allowable Clip Load</b>	<b>2,662</b>			<b>1,923</b>			<b>1,895</b>		<b>3,870</b>		

\*\*StiffClip LB Allowable Load tables and important notes continued on next page.

### Nomenclature

StiffClip LB is available for various stud depths. To specify, multiply stud depth by 100.

**Example:** 6" stud depth  
**Designate:** StiffClip® LB600

StiffClip® LB, Recommended Allowable Load (lbs):												
Screw Patterns with #12 Screws	F3 Load Direction											
	LB800 (4" Offset)			LB1000 (Standard 2" Offset)			LB1000 (4" Offset)			LB1200 (STANDARD 2" OFFSET)		
	Pattern 6: 4 Screws	Pattern 7: 6 Screws	Pattern 8: 8 Screws	Pattern 1: 2 Screws	Pattern 2: 3 Screws	Pattern 3: 4 Screws	Pattern 12: 4 Screws	Pattern 13: 6 Screws	Pattern 14: 10 Screws	Pattern 9: 2 Screws	Pattern 10: 3 Screws	Pattern 11: 4 Screws
33mil (20ga), 33ksi Stud	259	331	417	216	301	431	290	410	602	211	291	421
33mil (20ga), 50ksi Stud	375	479	604	313	435	623	419	593	870	305	422	609
43mil (18ga), 33ksi Stud	386	493	622	322	448	641	431	610	896	314	434	627
43mil (18ga), 50ksi Stud	559	713	899	466	648	927	624	883	1,192	454	628	907
54mil (16ga), 33ksi Stud	544	693	875	453	630	902	607	859	1,192	441	611	883
54mil (16ga), 50ksi Stud	785	1,001	1,263	654	910	1,303	876	1,192	1,192	637	882	1,275
68mil (14ga), 50ksi Stud	989	1,262	1,561	825	1,147	1,642	1,104	1,192	1,192	803	1,111	1,606
97mil (12ga), 50ksi Stud	989	1,262	1,561	825	1,147	1,642	1,104	1,192	1,192	803	1,111	1,606
<b>Maximum Allowable Clip Load</b>	<b>1,561</b>			<b>1,923</b>			<b>1,192</b>			<b>1,902</b>		

**Load Table Notes:**

1. Design loads are for attachment of StiffClip LB to stud only. Load tables reflect in plane of wall loads (F1), horizontal loads (F2) and vertical loads (F3).
2. Design loads consider loads on the clip and #12 screw fasteners to the stud web.
3. Loads listed reflect force in a single direction. When multiple loads react on the connection, it is the responsibility of the designer to check the interaction of forces.
4. Torsional effects are considered on screw group for F3 allowable loads. It is assumed that half of the torsional moment is taken by the connection to the structure and half is taken by the connection to the stud.
5. Attachment to structure engineered by others.
6. Allowable loads have not been increased for wind, seismic, or other factors.
7. Allowable load tables incorporate eccentric loading of fasteners. Values with a welded connection may increase.
8. Fasten within 3/4" from the angle heel (centerline of the 1-1/2" leg) to minimize eccentric load transfer.
9. Strengthening ribs are present in 3-5/8", 6", and 8" clip sizes. 10" and 12" clip sizes contain 1/2" return lips on the top and bottom of the leg attaching to the stud for increased stiffness.
10. For LRFD strengths contact TSN technical services.

**Load Direction**

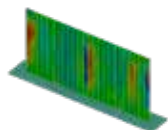
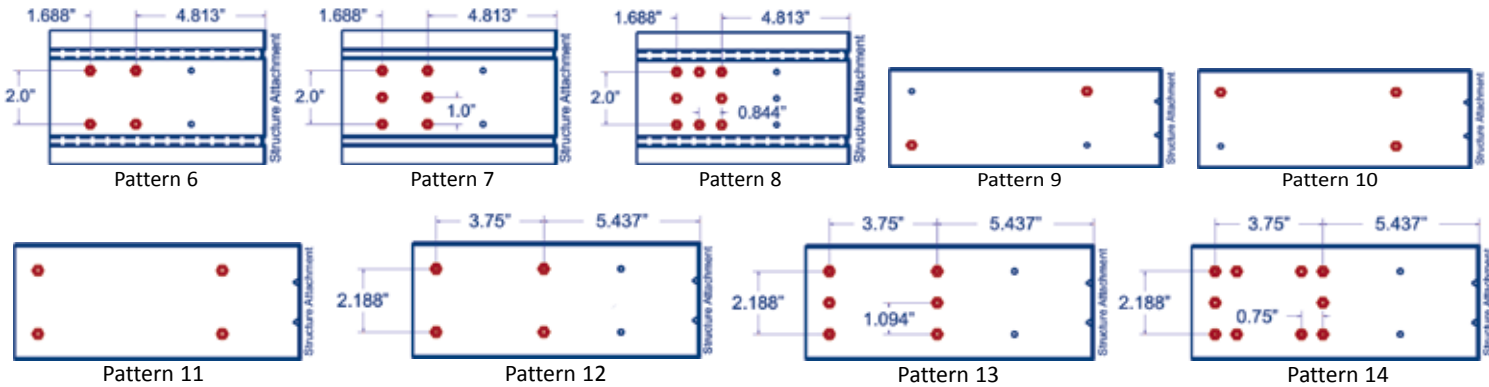
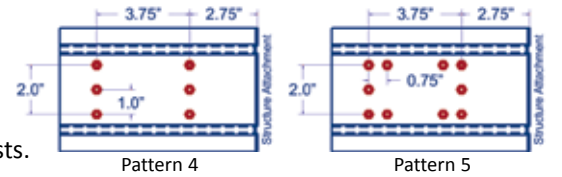
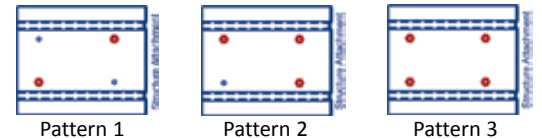
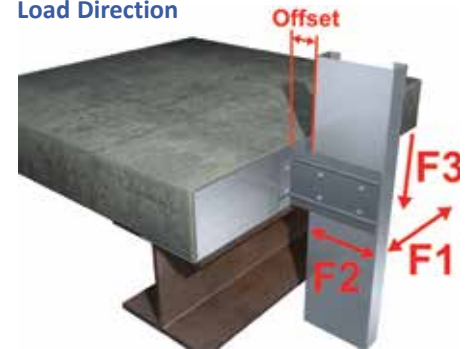

StiffClip LB Series  
Blast and Seismic Design Data  
www.steelnetwork.com

\*\* For more information or to review a copy of this report, please visit our website at <http://www.steelnetwork.com/light-steel-framing-design-resources>

# StiffClip® LB-HD

Spandrel Wall Bypass for Seismic Conditions

### Material Composition

ASTM A1003/A1003M Structural Grade 50 (340) Type H, ST50H (ST340H): 50ksi (340 MPa) minimum yield strength, 65ksi minimum tensile strength, 68mil minimum thickness (14 gauge, 0.0713" design thickness) with ASTM A653/653M G90 (Z275) hot dipped galvanized coating.

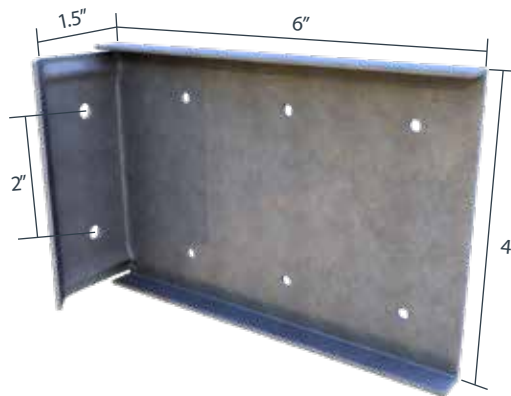

### StiffClip LB-HD Allowable Loads

StiffClip® LB-HD, Recommended Allowable Load (lbs): F1, F2 & F3									
Screw Patterns with #12 Screws	F1 Load Direction			F2 Load Direction			F3 Load Direction		
	LB600-HD			LB600-HD			LB600-HD		
	3 Screws	4 Screws	6 Screws	3 Screws	4 Screws	6 Screws	3 Screws	4 Screws	6 Screws
33mil (20ga), 33ksi Stud	190	190	190	522	752	1,128	317	449	598
33mil (20ga), 50ksi Stud	276	276	276	755	1,088	1,130	459	650	865
43mil (18ga), 33ksi Stud	248	248	248	777	1,120	1,130	472	669	891
43mil (18ga), 50ksi Stud	358	358	358	1,124	1,130	1,130	683	967	1,289
54mil (16ga), 33ksi Stud	312	312	312	1,094	1,130	1,130	664	941	1,254
54mil (16ga), 50ksi Stud	450	450	450	1,130	1,130	1,130	959	1,359	1,810
68mil (14ga), 50ksi Stud	568	568	568	1,130	1,130	1,130	1,209	1,712	1,966
97mil (12ga), 50ksi Stud	810	810	810	1,130	1,130	1,130	1,209	1,712	1,966
<b>Maximum Allowable Clip Load</b>	<b>857</b>			<b>1,130</b>			<b>1,966</b>		

### Load Table Notes:

- Design loads are for attachment of StiffClip LB-HD to stud only. Load tables reflect in plane of wall loads (F1), horizontal loads (F2) and vertical loads (F3).
- Design loads consider loads on the clip and #12 screw fasteners to the stud web.
- Loads listed reflect force in a single direction. When multiple loads react on the connection, it is the responsibility of the designer to check the interaction of forces.
- Torsional effects are considered on screw group for F3 allowable loads. It is assumed that half of the torsional moment is taken by the connection to the structure and half is taken by the connection to the stud.
- Attachment to structure engineered by others.
- Allowable loads have not been increased for wind, seismic, or other factors.
- Guideholes for stud connection are 0.172" diameter for #12 screws. Guideholes for structure connection are 3/8" diameter for (2) 1/4" diameter anchors.
- Fasten within 3/4" from the angle heel (centerline of the 1-1/2" leg) to minimize eccentric load transfer.
- For LRFD strengths contact TSN technical services.

### Load Direction

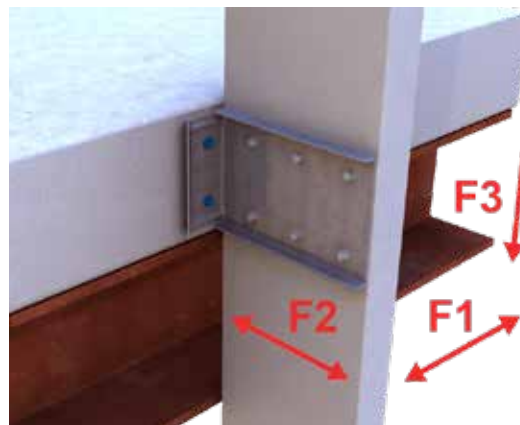

### Nomenclature

StiffClip LB-HD is designed to be used with 6" studs and is designated *StiffClip® LB600-HD*

### Screw Patterns

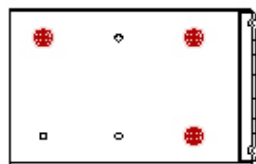

3 Screw Pattern

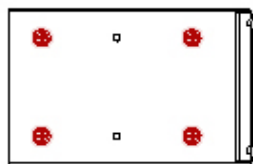

4 Screw Pattern

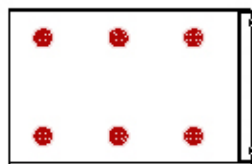

6 Screw Pattern

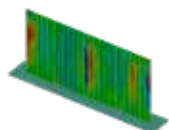

StiffClip LB-HD Series  
Blast and Seismic Design Data  
www.steelnetwork.com

\*\* For more information or to review a copy of this report, please visit our website at <http://www.steelnetwork.com/light-steel-framing-design-resources>

# VertiClip® Splice

Multi-Stud Bypass

### Material Composition

ASTM A1003/A1003M Structural Grade 50 (340) Type H, ST50H (ST340H): 50ksi (340MPa) minimum yield strength, 65ksi (450MPa) minimum tensile strength, 68mil minimum thickness (14 gauge, 0.0713" design thickness) with ASTM A653/A653M G90 (Z275) hot dipped galvanized coating.

The attachment of VertiClip to the primary structure may be made with PAFs, screw/bolt anchors or weld and is dependent upon the base material (steel or concrete) and the design configuration.

### VertiClip Splice Allowable Loads



US Patent # 5,906,080

VertiClip® Splice, Recommended Allowable Load (lbs): F2 & F3						
Screw Patterns with #12 Screws	F2 Load Direction					
	Splice600 & Splice800					
	2 Screws / 2 Screws	4 Screws / 2 Screws	4 Screws / 3 Screws	6 Screws / 2 Screws	2 Screws / 2 Screws	6 Screws / 3 Screws
33mil (20ga), 33ksi Stud	752	1,040	1,228	1,040	1,228	468
33mil (20ga), 50ksi Stud	1,088	1,208	1,328	1,208	1,328	677
43mil (18ga), 33ksi Stud	1,120	1,224	1,328	1,224	1,328	697
43mil (18ga), 50ksi Stud	1,328	1,328	1,328	1,328	1,328	1,008
54mil (16ga), 33ksi Stud	1,328	1,328	1,328	1,328	1,328	981
54mil (16ga), 50ksi Stud	1,328	1,328	1,328	1,328	1,328	1,417
68mil (14ga), 33ksi Stud	1,328	1,328	1,328	1,328	1,328	1,387
68mil (14ga), 50ksi Stud	1,328	1,328	1,328	1,328	1,328	1,785
97mil (12ga), 33ksi Stud	1,328	1,328	1,328	1,328	1,328	1,785
97mil (12ga), 50ksi Stud	1,328	1,328	1,328	1,328	1,328	1,785
118mil (10ga), 50ksi Stud	1,328	1,328	1,328	1,328	1,328	1,785
Maximum Allowable Clip Load	1,328					

### Load Direction

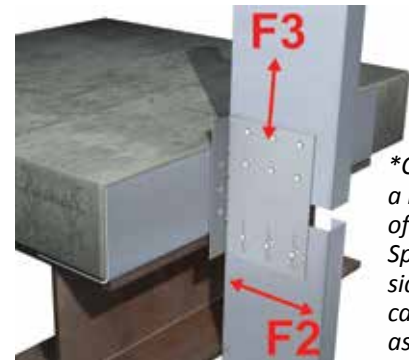

\*Clip shown is a left version of VertiClip Splice. Right side versions can be made as a custom part.

### Screw Patterns

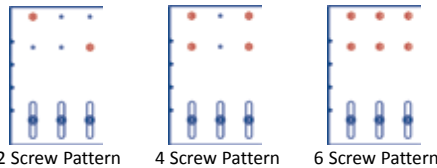

### Load Table Notes:

- Design loads are for attachment of VertiClip Splice to stud only. Load tables reflect horizontal loads (F2) and vertical loads (F3).
- Design loads consider loads on the clip and #12 screw fasteners to the stud web.
- Loads listed reflect force in a single direction. When multiple loads react on the connection, it is the responsibility of the designer to check the interaction of forces.
- Torsional effects are considered on screw group for F3 allowable loads. It is assumed that half of the torsional moment is taken by the connection to the structure and half is taken by the connection to the stud.
- Attachment to structure engineered by others.
- Allowable loads have not been increased for wind, seismic, or other factors.
- Total vertical deflection of up to 2" (1" up and 1" down). Deflection requirements greater than 1" up and down are available.
- Fasten within 3/4" from the angle heel (centerline of the 1-1/2" leg) to minimize eccentric load transfer.
- For LRFD strengths contact TSN technical services.

### Nomenclature

VertiClip Splice is designated by multiplying stud depth by 100.

**Example:** 6" stud. **Designate:** VertiClip® Splice600

VertiClip® Splice, Recommended Allowable Load (lbs): F2 & F3						
Screw Patterns with #12 Screws	F3 Load Direction					
	Splice600			Splice800 (up to 2" offset for 6" Studs)		
	2 Screws in Upper Half	4 Screws in Upper Half	6 Screws in Upper Half	2 Screws in Upper Half	4 Screws in Upper Half	6 Screws in Upper Half
33mil (20ga), 33ksi Stud	216	432	562	171	340	427
33mil (20ga), 50ksi Stud	313	626	813	248	492	617
43mil (18ga), 33ksi Stud	322	644	837	255	507	636
43mil (18ga), 50ksi Stud	466	932	1,211	369	733	919
54mil (16ga), 33ksi Stud	455	911	1,184	359	713	894
54mil (16ga), 50ksi Stud	654	1,309	1,701	518	1,030	1,292
68mil (14ga), 33ksi Stud	641	1,281	1,665	507	1,008	1,264
68mil (14ga), 50ksi Stud	825	1,649	2,144	652	1,298	1,628
97mil (12ga), 33ksi Stud	825	1,649	2,144	652	1,298	1,628
97mil (12ga), 50ksi Stud	825	1,649	2,144	652	1,298	1,628
118mil (10ga), 50ksi Stud	825	1,649	2,144	652	1,298	1,628
Maximum Allowable Clip Load	2,432			2,272		

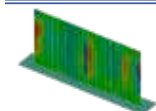

VertiClip Splice Series  
 Blast and Seismic Design Data  
 www.steelnetwork.com\*\*

\*\* For more information or to review a copy of this report, please visit our website at <http://www.steelnetwork.com/light-steel-framing-design-resources>

# StiffClip® CL

Floor Tie



### Material Composition

**68mil Clip:** ASTM A1003/A1003M Structural Grade 50 (340) Type H, ST50H (ST340H): 50ksi (340MPa) minimum yield strength, 65ksi (450MPa) minimum tensile strength, 68mil minimum thickness (14 gauge, 0.0713" design thickness) with ASTM A653/A653M G90 (Z275) hot dipped galvanized coating.

**118mil Clip:** ASTM A1003/A1003M Structural Grade 50 (340) Type H, ST50H (ST340H): 50ksi (340MPa) minimum yield strength, 65ksi (450MPa) minimum tensile strength, 118mil minimum thickness (10 gauge, 0.1242" design thickness) with ASTM A653/A653M G90 (Z275) hot dipped galvanized coating.

**"H" Plate:** ½" steel, ASTM A36, 36ksi min yield, 58-80ksi min tensile, with ASTM B633 Type II Yellow Zinc Coating, or Paint, or Equivalent.

The attachment of StiffClip to the primary structure may be made with PAFs, screw/bolt anchors or weld and is dependent upon the base material (steel or concrete) and the design configuration.

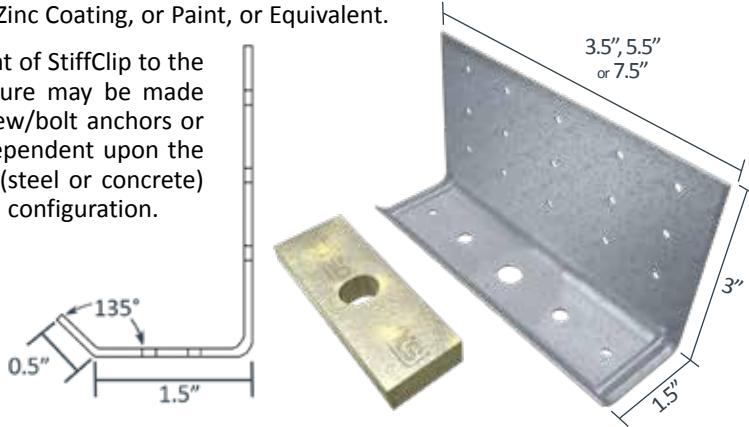

CL (H) Plate



US Patent #7,533,508

### StiffClip CL Allowable Loads

StiffClip® CL362/400, Recommended Allowable Load (lbs and inches): F1, F2, F3, M1 & Stiffness										
Screw Patterns with #12 Screws	CL362/400-68					CL362/400-118				
	Pattern 1: 4 Screws					Pattern 1: 4 Screws				
	F1 Load Direction	F2 Load Direction	F3 Load Direction	M1 Load Direction	M1 Stiffness	F1 Load Direction	F2 Load Direction	F3 Load Direction	M1 Load Direction	M1 Stiffness
33mil (20ga), 33ksi Stud	190	535	752	1,096	108,054	190	535	752	1,096	297,794
33mil (20ga), 50ksi Stud	276	774	1,088	1,586		276	774	1,088	1,586	
43mil (18ga), 33ksi Stud	248	796	1,120	1,633		248	796	1,120	1,633	
43mil (18ga), 50ksi Stud	358	1,152	1,151	1,804		358	1,152	1,620	2,362	
54mil (16ga), 33ksi Stud	312	1,121	1,151	1,804		312	1,121	1,576	2,297	
54mil (16ga), 50ksi Stud	450	1,618	1,151	1,804		450	1,618	2,225	3,318	
68mil (14ga), 33ksi Stud	392	1,584	1,151	1,804		392	1,584	2,225	3,248	
68mil (14ga), 50ksi Stud	568	1,917	1,151	1,804		568	2,039	2,225	3,936	
97mil (12ga), 33ksi Stud	560	1,917	1,151	1,804		560	2,039	2,225	3,936	
97mil (12ga), 50ksi Stud	810	1,917	1,151	1,804		810	2,039	2,225	3,936	
118mil (10ga), 50ksi Stud	988	1,917	1,151	1,804		988	2,039	2,225	3,936	
Max Allowable Clip Load	1,416	1,917	1,151	1,804	2,423	4,107	2,225	3,936		

### StiffClip® CL362/400, Recommended Allowable Load (lbs and inches): F1, F2, F3, M1 & Stiffness

Screw Patterns with #12 Screws	CL362/400-118 (H)				
	Pattern 2: 9 Screws				
	F1 Load Direction	F2 Load Direction	F3 Load Direction	M1 Load Direction	M1 Stiffness
33mil (20ga), 33ksi Stud	285	1,023	1,692	1,644	457,277
33mil (20ga), 50ksi Stud	414	1,480	2,448	2,379	
43mil (18ga), 33ksi Stud	372	1,523	2,520	2,449	
43mil (18ga), 50ksi Stud	537	2,203	3,645	3,542	
54mil (16ga), 33ksi Stud	468	2,143	3,546	3,446	
54mil (16ga), 50ksi Stud	675	3,095	5,121	4,977	
68mil (14ga), 33ksi Stud	588	3,030	5,013	4,872	
68mil (14ga), 50ksi Stud	852	3,900	5,713	6,271	
97mil (12ga), 33ksi Stud	840	3,900	5,713	6,271	
97mil (12ga), 50ksi Stud	1,215	3,900	5,713	6,271	
118mil (10ga), 50ksi Stud	1,482	3,900	5,713	6,271	
Max Allowable Clip Load	1,482	4,978	5,713	6,716	

**\*\*StiffClip CL Allowable Load tables and important notes continued on next page.**

StiffClip® CL600, Recommended Allowable Load (lbs and inches): F1, F2, F3, M1 & Stiffness										
Screw Patterns with #12 Screws	CL600-68					CL600-118				
	Pattern 3: 6 Screws					Pattern 3: 6 Screws				
	F1 Load Direction	F2 Load Direction	F3 Load Direction	M1 Load Direction	M1 Stiffness	F1 Load Direction	F2 Load Direction	F3 Load Direction	M1 Load Direction	M1 Stiffness
33mil (20ga), 33ksi Stud	285	872	1,067	1,788	160,215	285	872	1,128	1,788	354,427
33mil (20ga), 50ksi Stud	414	1,262	1,067	2,435		414	1,262	1,632	2,588	
43mil (18ga), 33ksi Stud	372	1,299	1,067	2,435		372	1,299	1,680	2,664	
43mil (18ga), 50ksi Stud	537	1,879	1,067	2,435		537	1,879	2,225	3,853	
54mil (16ga), 33ksi Stud	468	1,828	1,067	2,435		468	1,828	2,225	3,748	
54mil (16ga), 50ksi Stud	675	2,510	1,067	2,435		675	2,640	2,225	5,413	
68mil (14ga), 33ksi Stud	588	2,510	1,067	2,435		588	2,584	2,225	5,299	
68mil (14ga), 50ksi Stud	852	2,510	1,067	2,435		852	3,327	2,225	5,702	
97mil (12ga), 33ksi Stud	840	2,510	1,067	2,435		840	3,327	2,225	5,702	
97mil (12ga), 50ksi Stud	1,215	2,510	1,067	2,435		1,215	3,327	2,225	5,702	
118mil (10ga), 50ksi Stud	1,421	2,510	1,067	2,435		1,482	3,327	2,225	5,702	
<b>Max Allowable Clip Load</b>	<b>1,421</b>	<b>2,510</b>	<b>1,067</b>	<b>2,435</b>		<b>2,583</b>	<b>4,107</b>	<b>2,225</b>	<b>5,702</b>	

StiffClip® CL600, Recommended Allowable Load (lbs and inches): F1, F2, F3, M1 & Stiffness					
Screw Patterns with #12 Screws	CL600-118 (H)				
	Pattern 4: 10 Screws				
	F1 Load Direction	F2 Load Direction	F3 Load Direction	M1 Load Direction	M1 Stiffness
33mil (20ga), 33ksi Stud	380	1,478	1,880	3,157	525,127
33mil (20ga), 50ksi Stud	552	2,138	2,720	4,568	
43mil (18ga), 33ksi Stud	496	2,201	2,800	4,702	
43mil (18ga), 50ksi Stud	716	3,184	4,050	6,801	
54mil (16ga), 33ksi Stud	624	3,097	3,940	6,617	
54mil (16ga), 50ksi Stud	900	4,473	5,690	7,306	
68mil (14ga), 33ksi Stud	784	4,379	5,570	7,306	
68mil (14ga), 50ksi Stud	1,136	5,636	6,007	7,306	
97mil (12ga), 33ksi Stud	1,120	5,636	6,007	7,306	
97mil (12ga), 50ksi Stud	1,620	5,636	6,007	7,306	
118mil (10ga), 50ksi Stud	1,976	5,636	6,007	7,306	
<b>Max Allowable Clip Load</b>	<b>4,158</b>	<b>6,455</b>	<b>6,007</b>	<b>7,306</b>	

StiffClip® CL800, Recommended Allowable Load (lbs and inches): F1, F2, F3, M1 & Stiffness										
Screw Patterns with #12 Screws	CL800-68					CL800-118				
	Pattern 3: 6 Screws					Pattern 3: 6 Screws				
	F1 Load Direction	F2 Load Direction	F3 Load Direction	M1 Load Direction	M1 Stiffness	F1 Load Direction	F2 Load Direction	F3 Load Direction	M1 Load Direction	M1 Stiffness
33mil (20ga), 33ksi Stud	285	973	1,077	2,483	190,670	285	973	1,128	2,483	548,677
33mil (20ga), 50ksi Stud	414	1,408	1,077	2,860		414	1,408	1,632	3,592	
43mil (18ga), 33ksi Stud	372	1,449	1,077	2,860		372	1,449	1,680	3,697	
43mil (18ga), 50ksi Stud	537	2,096	1,077	2,860		537	2,096	2,430	5,348	
54mil (16ga), 33ksi Stud	468	2,039	1,077	2,860		468	2,039	2,364	5,203	
54mil (16ga), 50ksi Stud	675	2,662	1,077	2,860		675	2,945	2,666	7,514	
68mil (14ga), 33ksi Stud	588	2,662	1,077	2,860		588	2,883	2,666	7,355	
68mil (14ga), 50ksi Stud	852	2,662	1,077	2,860		852	3,711	2,666	8,229	
97mil (12ga), 33ksi Stud	840	2,662	1,077	2,860		840	3,711	2,666	8,229	
97mil (12ga), 50ksi Stud	1,215	2,662	1,077	2,860		1,215	3,711	2,666	8,229	
118mil (10ga), 50ksi Stud	1,435	2,662	1,077	2,860		1,482	3,711	2,666	8,229	
<b>Max Allowable Clip Load</b>	<b>1,435</b>	<b>2,662</b>	<b>1,077</b>	<b>2,860</b>		<b>3,356</b>	<b>6,410</b>	<b>2,666</b>	<b>8,229</b>	

**\*\*StiffClip CL Allowable Load tables and important notes continued on next page.**

StiffClip® CL800, Recommended Allowable Load (lbs and inches): F1, F2, F3, M1 & Stiffness					
Screw Patterns with #12 Screws	CL800-118 (H)				
	Pattern 4: 10 Screws				
	F1 Load Direction	F2 Load Direction	F3 Load Direction	M1 Load Direction	M1 Stiffness
33mil (20ga), 33ksi Stud	380	1,661	1,880	4,748	696,515
33mil (20ga), 50ksi Stud	552	2,402	2,720	6,869	
43mil (18ga), 33ksi Stud	496	2,473	2,800	7,071	
43mil (18ga), 50ksi Stud	716	3,577	4,050	10,227	
54mil (16ga), 33ksi Stud	624	3,480	3,940	9,950	
54mil (16ga), 50ksi Stud	900	5,026	5,690	11,143	
68mil (14ga), 33ksi Stud	784	4,920	5,570	11,143	
68mil (14ga), 50ksi Stud	1,136	6,333	7,170	11,143	
97mil (12ga), 33ksi Stud	1,120	6,333	7,170	11,143	
97mil (12ga), 50ksi Stud	1,620	6,333	7,170	11,143	
118mil (10ga), 50ksi Stud	1,976	6,333	7,170	11,143	
<b>Max Allowable Clip Load</b>	<b>4,816</b>	<b>8,274</b>	<b>7,446</b>	<b>11,143</b>	

Load Direction

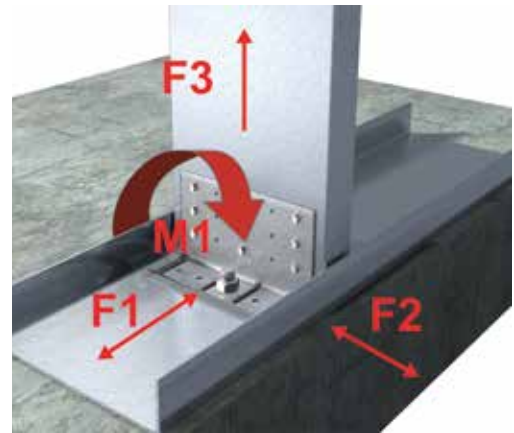

Load Table Notes:

- Design loads are for attachment of StiffClip CL to stud only. Load tables reflect in plane of wall loads (F1), horizontal loads (F2), vertical loads (F3), and overturning loads (M1).
- M1 loads are reported as Max. Load divided by a Factor of Safety. M1 loads may be limited by the Serviceability Load calculated as Clip Stiffness times the Serviceability Limit in radian.
- Stiffness is the Allowable Clip Moment divided by the clip rotation measured at half of the Max Allowable Clip Moment.
- Design loads consider loads on the clip and #12 screw fasteners to the stud web.
- Loads listed reflect force in a single direction. When multiple loads react on the connection, it is the responsibility of the designer to check the interaction of forces.
- Torsional effects are considered on screw group for F2 allowable loads. It is assumed that half of the torsional moment is taken by the connection to the structure and half is taken by the connection to the stud.
- Attachment to structure engineered by others.
- Allowable loads have not been increased for wind, seismic, or other factors.
- Allowable load tables incorporate eccentric loading of fasteners. Values with a welded connection may increase.
- Guide holes are in place for fastener installation efficiency. All guide holes may not require fasteners. Fastener amount determined by the designer. Screw fastener should be symmetrically placed in guide holes. Refer to screw pattern diagrams below for placement.
- Fasten within 3/4" from the angle heel (centerline of the 1-1/2" leg) to minimize eccentric load transfer.
- Center guide hole is 9/16" in diameter for 1/2" anchors. Middle guide holes are 5/16" in diameter for 3/8" anchors. Outer guide holes and guide holes in 3" leg are 0.141" in diameter.
- For LRFD strengths contact TSN technical services.

Screw Patterns

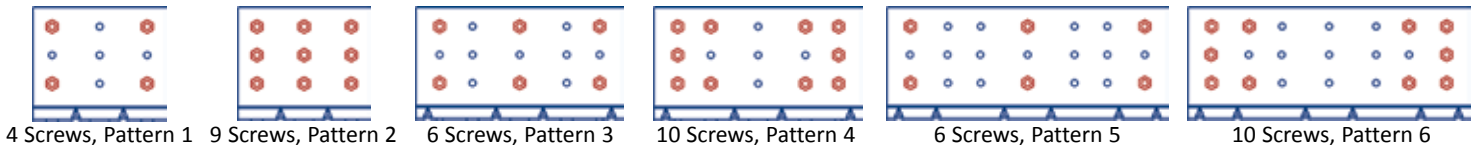

Nomenclature

To specify StiffClip CL on drawings, multiply stud depth by 100, followed by the appropriate material thickness, based on strength required (see load tables). The StiffClip CL118(H) utilizes a plate in the 1 1/2" leg (shown on page 1).

**Example:** 6" stud, uplift load of 650lbs  
**Designate:** StiffClip® CL600-68

**Anchor Bolt Design**

The following equation for tension force in the anchor is derived using the assumed bearing stress distribution shown in the figure to the right. This assumed stress distribution provides a conservative anchor force approximation.

$$T = \frac{M}{\left(\frac{2}{3}\right)\left(d_{clip}/2\right)} = \frac{3M}{d_{clip}}$$

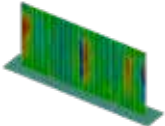
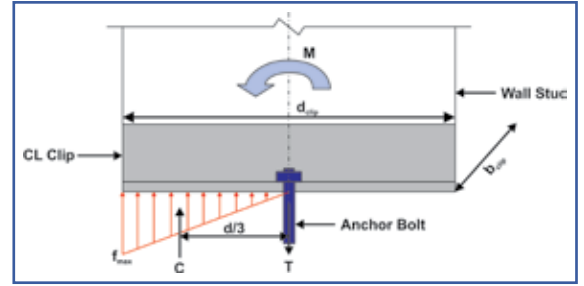

StiffClip CL Series  
 Blast and Seismic Design Data  
[www.steelnetwork.com](http://www.steelnetwork.com)

**\*\* For more information or to review a copy of this report, please visit our website at <http://www.steelnetwork.com/light-steel-framing-design-resources>**

# MidWall™

Partial Wall Framing

The Steel Network, Inc.   
 www.steelnetwork.com  
 1-888-474-4876

### Material Composition

**MidWall:** ASTM A1003/A1003M Structural Grade 50 (340) Type H, ST50H (ST340H), 50ksi (340MPa) minimum yield strength, 65ksi (450MPa) minimum tensile strength, G90 (Z275) hot-dipped galvanized coating. Material Thickness = 118mil (10 gauge, 0.1242" design thickness) for 250MW and 362MW. Material Thickness = 97mil (12 gauge, 0.1017" design thickness) for 600 MW.

**MidWall Plate:** ASTM A36/A36M: 36ksi (250MPa) minimum yield strength, 58-80ksi (400-550MPa) tensile strength, 1/2" minimum thickness.

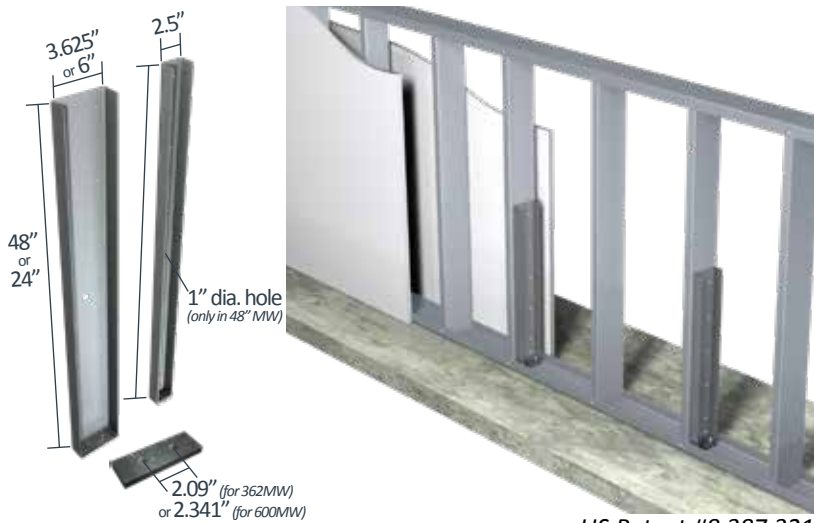

US Patent #8,387,321

### MidWall Allowable Loads

Wall Width (in)	MidWall™ Member	Maximum Point Load @ 48" (ASD), lbs	Maximum Base Moment, lbs-in
2 1/2	250MW	128	6,150
3 5/8"	362MW	332	15,940
6	600MW	407	19,540

### Notes

- MidWall is designed to support out-of-plane loading in cantilevered partial wall systems that are unsupported at the top track.
- Out-of-plane loads are transferred to the floor system through plate nested in the flanges of the member with two 3/8" diameter fasteners (or one 1/2" diameter fastener for 250MW) used for the connection.
- MidWall may be used in place of standard framing members, or in conjunction with them to frame the wall.

### Nomenclature

MidWall is currently available in two heights and three depths. Product nomenclature lists the member depth first followed by the height in inches

**Example:** 6" web depth, 24" tall MidWall

**Designate:** 600MW-24

### Example Details

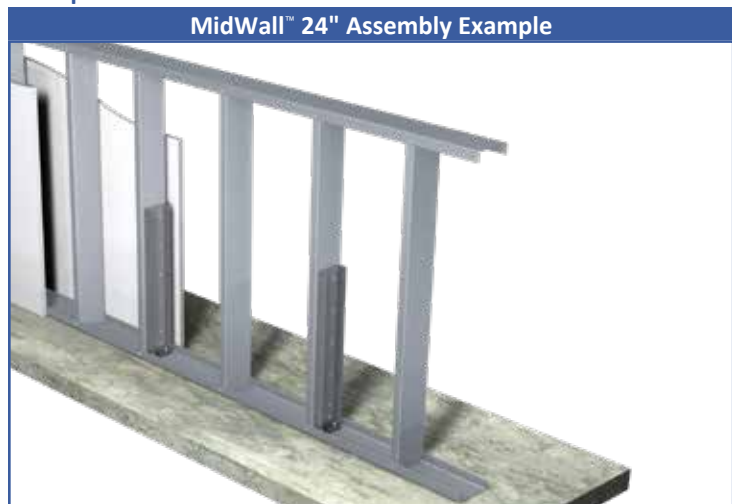

MidWall 24" is generally used in interior half walls of less than 48" in height. Attach MidWall 24" to a 54mil stud with #12 screws through all pre-drilled guide holes. Other studs in the walls are typical infill studs. Maximum spacing between MidWall connectors is 36" o.c. (see table on following page). Contact TSN Technical Services at (888) 474-4876 for design recommendations.

MidWall 48" is used in interior half walls equal to or more than 48" in height. Use one MidWall 48" as a substitute for a stud at the specified spacing, or attach to a 54mil stud with #12 screws through all pre-drilled guide holes. Maximum spacing between MidWall connectors is 36" o.c.

**Design Information**

**Criteria:**

IBC 2021

Refer to Section 1607.9.1

**Applications:**

- Handrails and Guards
- Interior Half Walls
- Parapets
- Ribbon Windows

**Handrails and Guards:**

- 50 lb/ft applied in any direction at the top of wall
- 200 lbs applied in any direction at any point at the top of the wall

**Parapets & Ribbon Windows:**

- Design Wind Pressure

**Interior Half Walls:**

- Design internal pressure

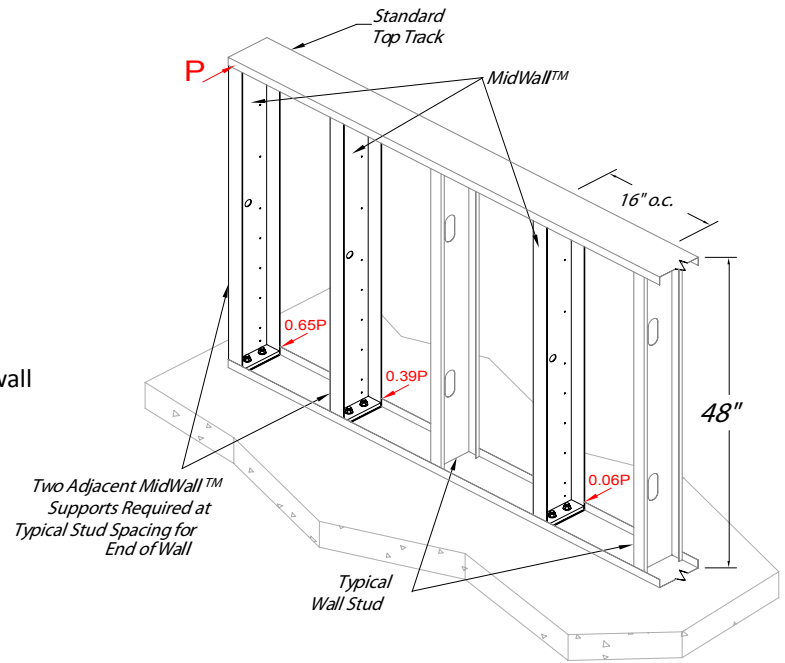

**Design Procedure**

The top track spanning between MidWall members acts as a load distribution member capable of distributing localized loads to multiple MidWall members. It is recommended to design the track in these applications. Refer to the diagram above for an example of the distribution of the point load, P, to adjacent MidWall supports. At the end of the wall, MidWall is required at adjacent stud spacings. Designed spacing begins after two adjacent end supports.

Max Applied Tension (T <sub>u</sub> ) on One Anchor (lbs)(LRFD)	250 MidWall™ ½" Anchorage Options (4,000 psi Minimum Normal Weight Cracked Concrete)
900	½" Screw-Bolt+, 2 ½" Nominal Embedment (Dewalt)
	½" Kwik HUS-EZ, 2 ¼" Nominal Embedment (Hilti)
1,200	½" Screw-Bolt+, 2 ½" Nominal Embedment (Dewalt)
	½" Kwik HUS-EZ, 2 ¼" Nominal Embedment (Hilti)
1,600	½" Screw-Bolt+, 3" Nominal Embedment (Dewalt)
	½" Kwik HUS-EZ, 3" Nominal Embedment (Hilti)

Max Applied Tension (T <sub>u</sub> ) on One Anchor (lbs)(LRFD)	362/600 MidWall™ ¾" Anchorage Options (4,000 psi Minimum Normal Weight Cracked Concrete)
1,800	(2) ¾" Screw-Bolt+, 3 ¼" Nominal Embedment (Dewalt)
	(2) ¾" Kwik Bolt TZ2 - CS, 3" Nominal Embedment (Hilti)
2,200	(2) ¾" Screw-Bolt+, 3 ¼" Nominal Embedment (Dewalt)
	(2) ¾" Kwik Bolt TZ2 - CS, 3" Nominal Embedment (Hilti)
2,400	(2) ¾" HAS-E Threaded Rod w/ HIT-HY 200 V3 Epoxy, 3" Effective Embedment (Hilti)
3,200	(2) ¾" HAS-E Threaded Rods w/ HIT-HY 200 V3 Epoxy, 4" Effective Embedment (Hilti)

# StiffClip® TD

Uplift Connector

The Steel Network, Inc.

www.steelnetwork.com

1-888-474-4876



### Material Composition

**TD-LT:** ASTM A1003/A1003M Structural Grade 50 (340) Type H, ST50H (ST340H): 50ksi (340MPa) minimum yield strength, 65ksi (450MPa) minimum tensile strength, 118mil minimum thickness (10 gauge, 0.1242" design thickness) with ASTM A653/A653M G90 (Z275) hot dipped galvanized coating.

**TD:** ASTM A1003/A1003M Structural Grade 55 (380) Type H, ST55H (ST380H): 55ksi (380MPa) minimum yield strength, 70ksi (480MPa) minimum tensile strength, 118mil minimum thickness (10 gauge, 0.1242" design thickness) with ASTM A653/A653M G90 (Z275) hot dipped galvanized coating.

**TD Plate:** ASTM A36/A36M: 36ksi (250MPa) minimum yield strength, 58-80ksi (400-550MPa) minimum tensile strength, with ASTM B633 Type II Yellow Zinc Coating, Paint, Powder Coating, or E-Coating, or approved equivalent.

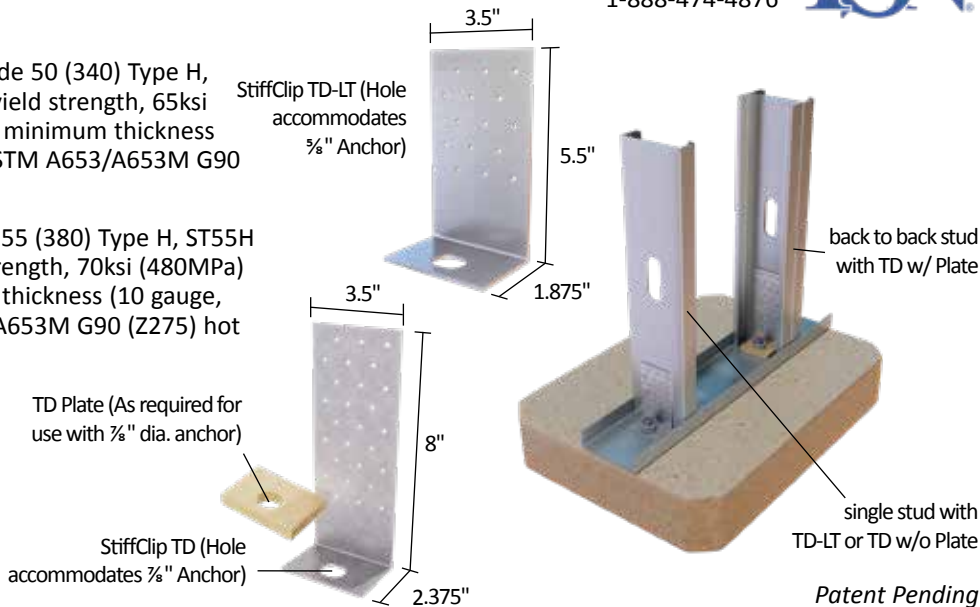

### StiffClip TD Allowable Loads for Steel Framing

StiffClip® TD, Recommended Allowable Loads for Steel Framing (lbs): F3 Load Direction									
Screw Patterns with #12 Screws	TD-LT			TD w/o Plate			TD w/ Plate		
	4 Screws	6 Screws	8 Screws	6 Screws	8 Screws	12 Screws	12 Screws	18 Screws	27 Screws
33mil (20ga), 33ksi Stud	752	1,128	1,504	1,128	1,504	2,256	2,256	3,384	5,076
33mil (20ga), 50ksi Stud	1,088	1,632	2,176	1,632	2,176	3,264	3,264	4,896	7,344
43mil (18ga), 33ksi Stud	1,120	1,680	2,240	1,680	2,240	3,360	3,360	5,040	7,560
43mil (18ga), 50ksi Stud	1,620	2,430	3,240	2,430	3,240	4,412	4,860	7,290	9,826
54mil (16ga), 33ksi Stud	1,576	2,364	3,152	2,364	3,152	4,412	4,728	7,092	9,826
54mil (16ga), 50ksi Stud	2,276	3,414	3,764	3,414	4,412	4,412	6,828	9,826	9,826
68mil (14ga), 50ksi Stud	2,868	3,764	3,764	4,302	4,412	4,412	8,604	9,826	9,826
97mil (12ga), 50ksi Stud	2,868	3,764	3,764	4,302	4,412	4,412	8,604	9,826	9,826
<b>Maximum Allowable Clip Load</b>	<b>3,764</b>			<b>4,412</b>			<b>9,826</b>		

### Table Notes:

1. Design loads are for attachment of StiffClip TD to stud only. Load tables reflect vertical loads (F3).
2. Design loads consider loads on the clip and #12 screw fasteners to the stud web for steel framing.
3. Attachment to structure engineered by others.
4. Allowable loads have not been increased for wind, seismic, or other factors.
5. Fasten within 1-1/4" from the heel angle using the existing anchor hole.
6. Guide holes are in place for fastener installation efficiency. The number of fasteners are determined by the designer.
7. Attachment to stud is made with up to 27 #12 screws, symmetrically place.
8. For LRFD strengths contact TSN technical services.

### Load Directions:

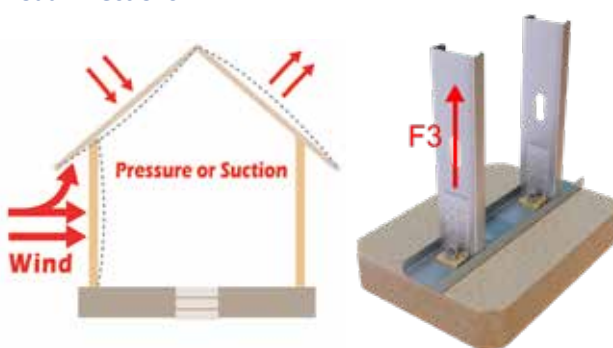

### Screw Patterns:

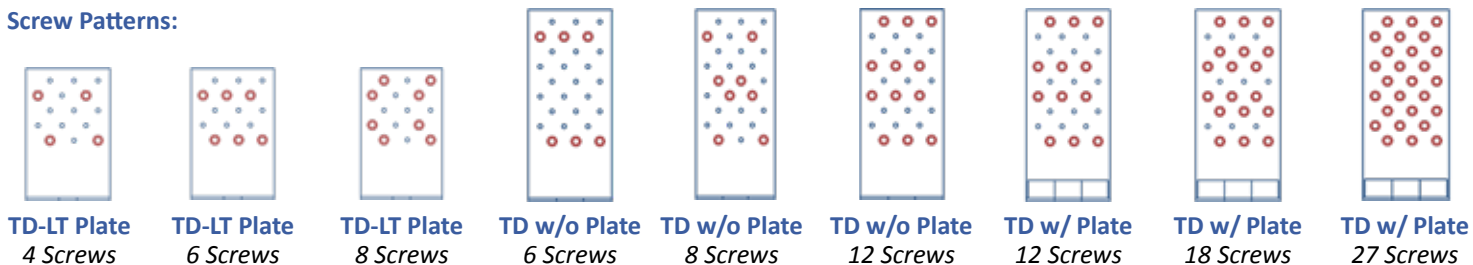

**StiffClip TD Allowable Loads**

StiffClip® TD-LT, Recommended Allowable Loads for Wood Framing (lbs): F3						
Screw/Nail Patterns	Douglas Fir / Southern Yellow Pine			Spruce Pine-Fir / Hem-Fir		
	8 Fasteners	12 Fasteners	18 Fasteners	8 Fasteners	12 Fasteners	18 Fasteners
10d Nails	1,830	2,746	3,764	1,472	2,208	3,312
16d Nails	2,125	3,187	3,764	1,715	2,573	3,764
#12 Wood Screw	2,227	3,764	3,764	1,792	2,688	3,764
<b>Maximum Allowable Clip Load</b>	<b>3,764</b>			<b>3,764</b>		

StiffClip® TD w/o Plate, Recommended Allowable Loads for Wood Framing (lbs): F3						
Screw/Nail Patterns	Douglas Fir / Southern Yellow Pine			Spruce Pine-Fir / Hem-Fir		
	8 Fasteners	12 Fasteners	18 Fasteners	8 Fasteners	12 Fasteners	18 Fasteners
10d Nails	1,830	2,746	4,118	1,472	2,208	3,312
16d Nails	2,125	3,187	4,412	1,715	2,573	3,859
#12 Wood Screw	2,227	3,341	4,412	1,792	2,688	4,032
<b>Maximum Allowable Clip Load</b>	<b>4,412</b>			<b>4,412</b>		

StiffClip® TD w/ Plate, Recommended Allowable Loads for Wood Framing (lbs): F3						
Screw/Nail Patterns	Douglas Fir / Southern Yellow Pine			Spruce Pine-Fir / Hem-Fir		
	8 Fasteners	12 Fasteners	18 Fasteners	8 Fasteners	12 Fasteners	18 Fasteners
10d Nails	2,746	4,118	6,178	2,208	3,312	4,968
16d Nails	3,187	4,781	7,171	2,573	3,859	5,789
#12 Wood Screw	3,341	5,011	7,517	2,688	4,032	6,048
<b>Maximum Allowable Clip Load</b>	<b>9,826</b>			<b>9,826</b>		

**Table Notes:**

1. Design loads are for attachment of StiffClip TD to stud only. Load tables reflect vertical loads (F3).
2. Design loads consider loads on the clip and listed fasteners to the stud web for wood framing.
3. Attachment to structure engineered by others.
4. Allowable shear for nails and screws is increased 60% for wind and seismic loads in wood framing.
5. Fasten within 1-1/4" from the heel angle using the existing anchor hole.
6. Guide holes are in place for fastener installation efficiency. The number of fasteners are determined by the designer.
7. Attachment to stud is made with up to 27 #12 screws, symmetrically place.
8. For wood with moisture content > 19%, consult The Steel Network, Inc. for reduction in values.
9. For LRFD strengths contact TSN technical services.

**Nomenclature**

StiffClip TD-LT is available in one size without the use of the 'TD Plate'. Contact TSN about installation with alternate anchor sizes. StiffClip TD is available in one size and can be used with or without a 3/4" plate on top of the 2 3/8" leg. Anchor hole accommodates 7/8" diameter anchor.

Example: 6" stud, 5/8" dia. anchor to concrete, holddown without plate

Designate: StiffClip® TD-LT

Example: 8" stud, 7/8" dia. anchor to concrete, holddown with plate

Designate: StiffClip® TD w/ Plate



### Steel Example Details

Stud Tie Down



X-Brace Shear Wall Column Anchor

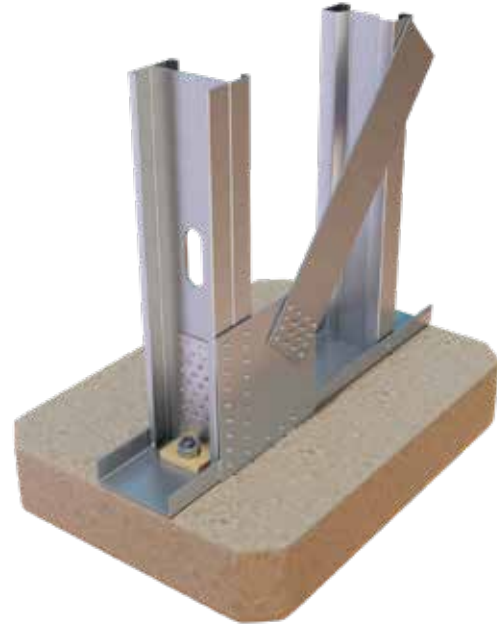

### Wood Example Details

Wood Stud Tie Down



Shear Wall Column Anchor (Wood Framing)



Other Example Details

Medical Equipment Anchor

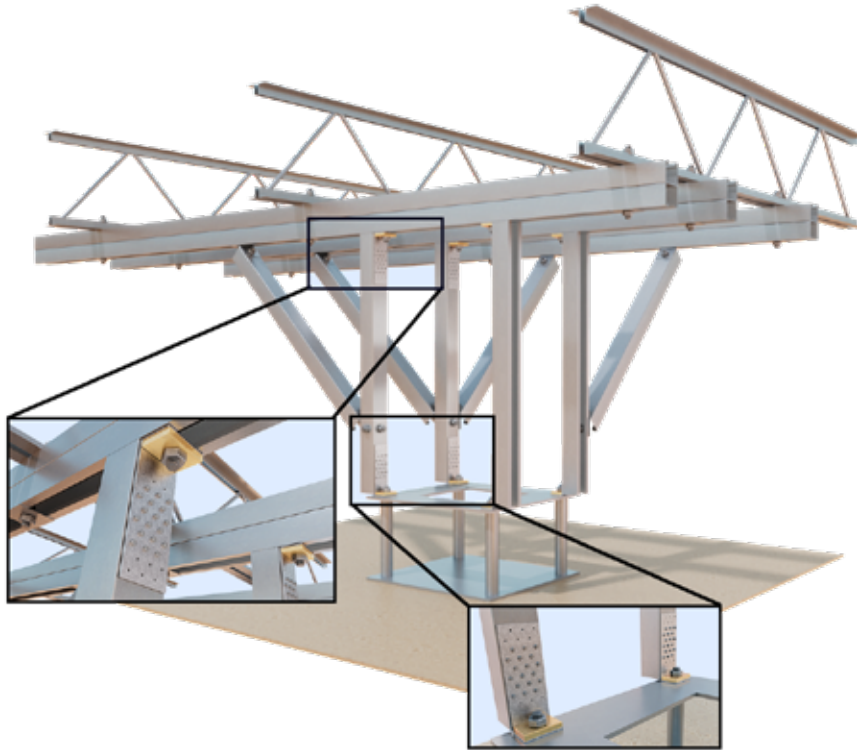

Joist/Truss Top Chord Anchor



Tension Tie Anchor

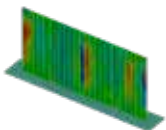
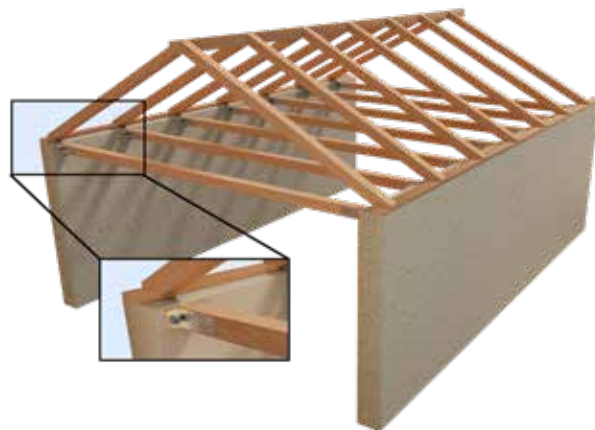

StiffClip TD Series  
Blast and Seismic Design Data  
[www.steelnetwork.com](http://www.steelnetwork.com)

\*\* For more information or to review a copy of this report, please visit our website at <http://www.steelnetwork.com/light-steel-framing-design-resources>

# StiffClip® PLC

Panel Lift Clip



### Material Composition

ASTM A1003/A1003M Structural Grade 50 (340) Type H, ST50H (ST340H): 50ksi (340MPa) minimum yield strength, 65ksi (450MPa) minimum tensile strength, 97mil minimum thickness (12 gauge, 0.1017" design thickness) with ASTM A653/A653M G90 (Z275) hot dipped galvanized coating.

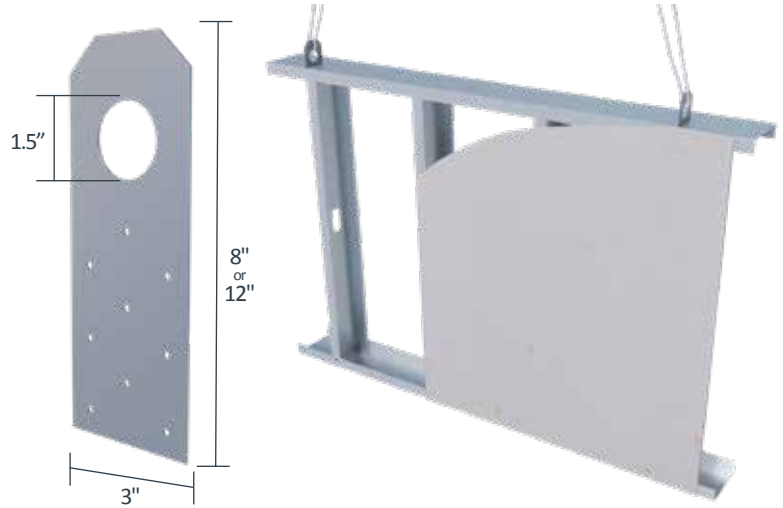

### StiffClip PLC Allowable Loads

StiffClip® PLC, Recommended Allowable Load for Steel Framing (lbs): F3 & F2												
Screw Patterns with #10 Screws	F2 Load Direction						F3 Load Direction					
	PLC-8-97			PLC-12-97			PLC-8-97			PLC-12-97		
	3 Screws	6 Screws	9 Screws	5 Screws	9 Screws	15 Screws	3 Screws	6 Screws	9 Screws	5 Screws	9 Screws	15 Screws
33mil (20ga), 33ksi Stud	106	306	373	166	237	517	531	1,062	1,361	885	1,361	1,361
33mil (20ga), 50ksi Stud	153	441	537	239	341	745	765	1,361	1,361	1,275	1,361	1,361
43mil (18ga), 33ksi Stud	158	455	554	247	352	768	789	1,361	1,361	1,315	1,361	1,361
43mil (18ga), 50ksi Stud	228	658	800	356	509	1,110	1,140	1,361	1,361	1,361	1,361	1,361
54mil (16ga), 33ksi Stud	222	641	779	347	495	1,081	1,110	1,361	1,361	1,361	1,361	1,361
54mil (16ga), 50ksi Stud	320	924	1,125	501	715	1,156	1,361	1,361	1,361	1,361	1,361	1,361
68mil (14ga), 50ksi Stud	329	949	1,154	514	734	1,156	1,361	1,361	1,361	1,361	1,361	1,361
97mil (12ga), 50ksi Stud	329	949	1,154	514	734	1,156	1,361	1,361	1,361	1,361	1,361	1,361
118mil (10ga), 50ksi Stud	329	949	1,154	514	734	1,156	1,361	1,361	1,361	1,361	1,361	1,361
<b>Maximum Allowable Clip Load</b>	<b>1,156</b>						<b>1,361</b>					

### Load Table Notes:

1. Design loads consider loads on the clip and #10 screw fasteners to steel framing.
2. Spacing between clips to be controlled by the weight of panel and presence of a spreader bar or a load distribution member
3. For screw patterns other than standard patterns shown, contact TSN technical services.
4. For LRFD strengths contact TSN technical services.

### Load Direction

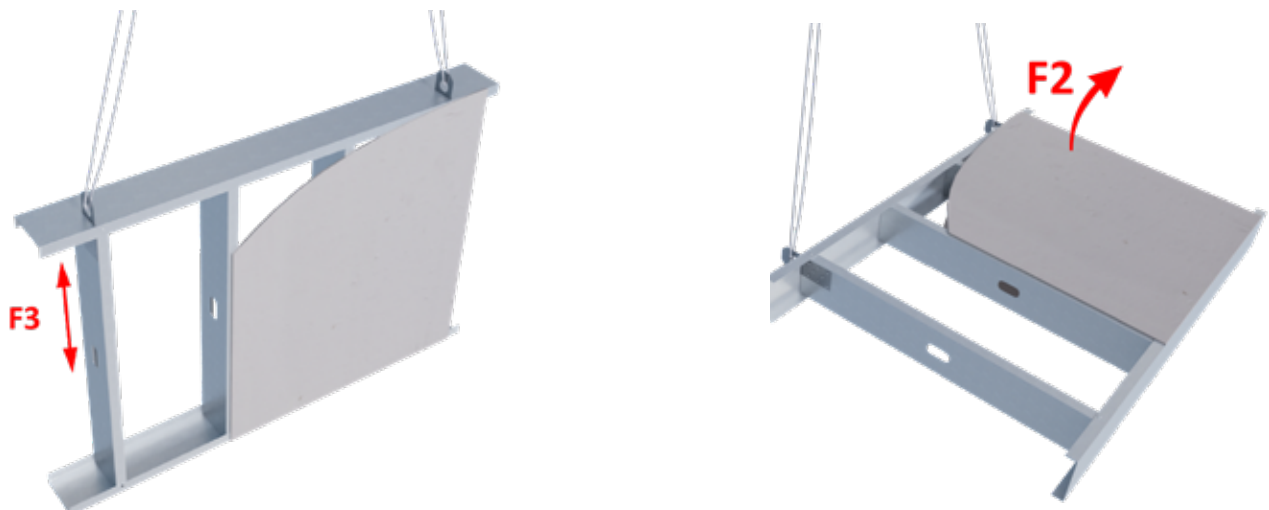

**Nomenclature**

StiffClip PLC is available in two sizes and is designated by the length of the clip, followed by mil thickness (-97)

**Example:** 8" Connector

**Designate:** StiffClip® PLC-8-97

**Example Details**



Double Attachment to Wall at End Stud



Attachment to Wall at Intermediate Stud



Attachment to Stud Web

**Screw Patterns for StiffClip® PLC**

3 Screw Pattern

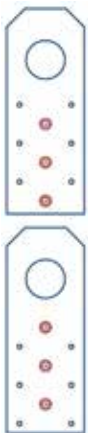

6 Screw Pattern



9 Screw Pattern



5 Screw Pattern

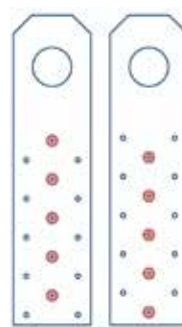

9 Screw Pattern

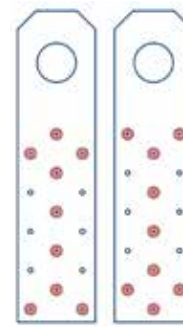

15 Screw Pattern

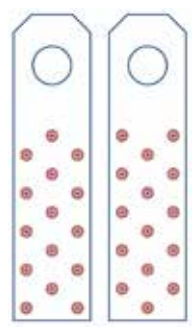

# StiffClip® HE

Header Connector

### Material Composition

**HE(L):** ASTM A1003/A1003M Structural Grade 50 (340) Type H, ST50H (ST340H): 50ksi (340MPa) minimum yield strength, 65ksi (450MPa) minimum tensile strength, 43mil minimum thickness (18 gauge, 0.0451" design thickness) with ASTM A653/A653M G90 (Z275) hot dipped galvanized coating.

**HE(H) & HE(S):** ASTM A1003/A1003M Structural Grade 50 (340) Type H, ST50H (ST340H): 50ksi (340MPa) minimum yield strength, 65ksi (450MPa) minimum tensile strength, 68mil minimum thickness (14 gauge, 0.0713" design thickness) with ASTM A653/A653M G90 (Z275) hot dipped galvanized coating.

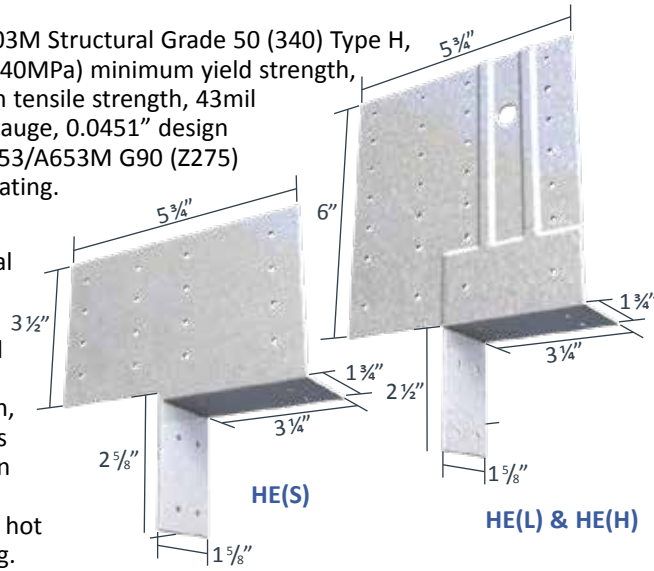

US Patent #7,634,889

### StiffClip HE Allowable Loads for a Single Clip: Screw Fasteners

StiffClip® HE(L), HE(H) & HE(S): F2 Load Direction (lbs)						
Screw Patterns with #10 Screws	HE(L)			HE(H) & HE(S)		
	4 screws	6 screws	8 screws	4 screws	6 screws	8 screws
33mil (20ga), 33ksi Stud	199	299	399	199	299	399
33mil (20ga), 50ksi Stud	287	431	574	287	431	574
43mil (18ga), 33ksi Stud	296	444	592	296	444	592
43mil (18ga), 50ksi Stud	428	627	627	428	642	856
54mil (16ga), 33ksi Stud	429	627	627	417	625	833
54mil (16ga), 50ksi Stud	564	627	627	601	902	1,088
68mil (14ga), 50ksi Stud	564	627	627	617	925	1,088
97mil (12ga), 50ksi Stud	564	627	627	617	925	1,088
<b>Max Allowable Clip Load</b>	<b>627</b>			<b>1,088</b>		

StiffClip® HE(L): F3 Load Direction (lbs)						
Screw Patterns with #10 Screws	HE(L)					
	8 screws	12 screws	16 screws	20 screws	24 screws	28 screws
33mil (20ga), 33ksi stud	536	708	873	1,090	1,239	1,340
33mil (20ga), 50ksi stud	773	1,020	1,257	1,571	1,785	1,930
43mil (18ga), 33ksi stud	797	1,052	1,297	1,620	1,841	1,991
43mil (18ga), 50ksi stud	1,151	1,520	1,873	2,341	2,660	2,877
54mil (16ga), 33ksi stud	1,154	1,524	1,878	2,347	2,667	2,884
54mil (16ga), 50ksi stud	1,518	2,004	2,470	3,066	3,066	3,066
68mil (14ga), 50ksi stud	1,518	2,004	2,470	3,066	3,066	3,066
97mil (12ga), 50ksi stud	1,518	2,004	2,470	3,066	3,066	3,066
<b>Max Allowable Clip Load</b>	<b>3,066</b>					

StiffClip® HE(H) & HE(S): F3 Load Direction (lbs)									
Screw Patterns with #10 Screws	HE(H)						HE(S)		
	8 Screws	12 Screws	16 Screws	20 Screws	28 Screws	24 Screws	8 Screws	12 Screws	16 Screws
33mil (20ga), 33ksi Stud	536	708	873	1,090	1,239	1,340	382	501	611
33mil (20ga), 50ksi Stud	773	1,020	1,257	1,571	1,785	1,930	551	722	880
43mil (18ga), 33ksi Stud	797	1,052	1,297	1,620	1,841	1,991	568	744	907
43mil (18ga), 50ksi Stud	1,151	1,520	1,873	2,341	2,660	2,877	821	1,075	1,311
54mil (16ga), 33ksi Stud	1,121	1,480	1,824	2,279	2,590	2,801	799	1,047	1,277
54mil (16ga), 50ksi Stud	1,618	2,136	2,633	3,289	3,738	4,042	1,153	1,511	1,842
68mil (14ga), 50ksi Stud	1,660	2,192	2,702	3,376	3,836	4,148	1,184	1,551	1,891
97mil (12ga), 50ksi Stud	1,660	2,192	2,702	3,376	3,836	4,148	1,184	1,551	1,891
<b>Max Allowable Clip Load</b>	<b>5,545</b>						<b>2,968</b>		

### Load Table Notes:

1. Torsional effects are considered on screw group for F2 & F3 allowable loads. It is assumed that half of the torsional moment is taken by the connection on one side and half is taken by the connection on the other side of the clip.
2. Attachment to stud is made with screws symmetrically placed. All guide holes may not require fasteners. Fastener amount determined by designer.
3. Allowable loads have not been increased for wind, seismic, or other factors.
4. The minimum combination of steel thickness and yield strength must be used when determining the maximum design load.
5. Design loads listed consider both loads on the clip and the #10 screws fastened to the jamb and header members.
6. Refer to screw patterns on the following page.
7. For LRFD strengths contact TSN technical services.

### Load Direction

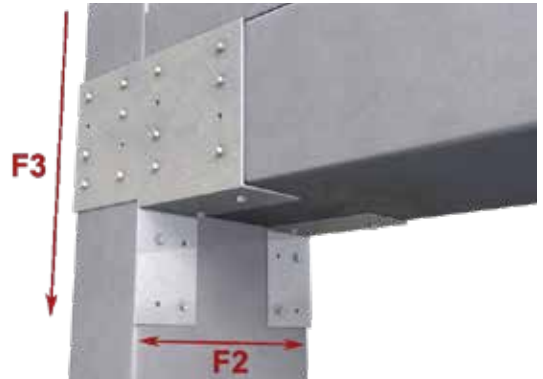

**Screw Patterns for HE(L) & HE(H) F3 Load Tables**

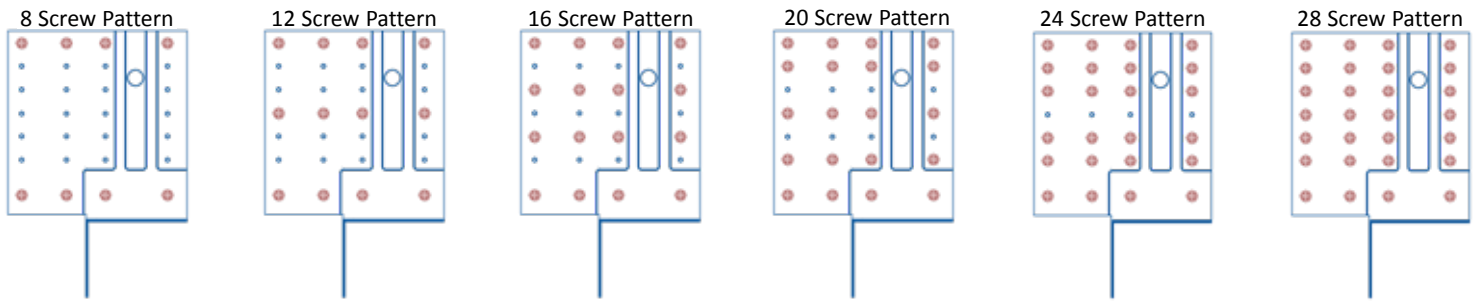

**Screw Patterns for HE(S) F3 Load Tables**

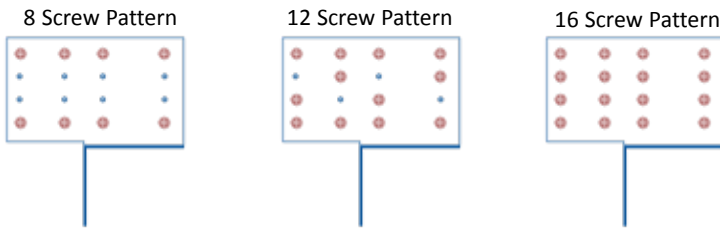

**Screw Patterns for F2 Load Tables**

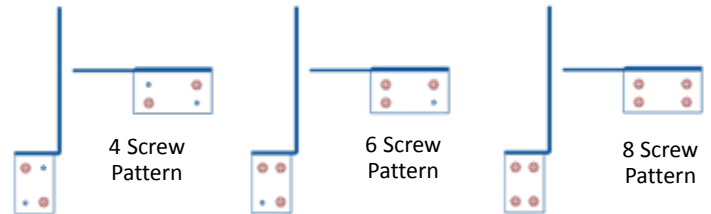

**Allowable Loads: Welded Connection**

StiffClip® HE(H): F3 Load Direction - Welded	
HE(H)	
54mil (16ga), 50ksi Stud (And Thicker)	4,177

**Notes:**

1. The standard StiffClip HE(H) clip does not include all four large holes in the web of the clip. Special orders for these clips can be made by request.
2. Allowable F3 welded values do not apply for the 43mil (18ga) StiffClip (HE(L)).
3. StiffClip HE(H) allowable F3 welded values are applicable to clips with welds around the perimeter of the single 1/2" diameter hole, three 3/8" diameter holes, and along each side of the clip. Weld size is not to exceed double the material thickness of the header or jamb, or 1/8". Care should be taken to not burn through the material.

**Nomenclature**

StiffClip HE is available in two thicknesses. The StiffClip HE(L) is 43mil (18ga), and the StiffClip HE(H) & HE(S) are both 68mil (14ga).

\* Clips are packaged as pairs. Four StiffClip HE clips are used at each opening: two left-hand and two right-hand clips attach the complete header to the jamb.

**Weld Diagram**

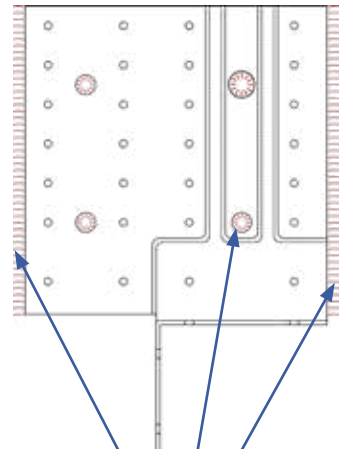

1/8" weld around three 3/8" diameter holes, one 1/2" diameter hole, with 1/8" welds along each side.



HE(S)



HE(L) & HE(H)

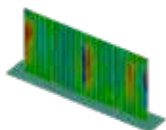

StiffClip HE Series  
Blast and Seismic Design Data  
www.steelnetwork.com

\*\* For more information or to review a copy of this report, please visit our website at <http://www.steelnetwork.com/light-steel-framing-design-resources>

# StiffClip® HS

## Jamb Stud Header and Sill Connector

The Steel Network, Inc.

www.steelnetwork.com

1-888-474-4876



### Material Composition

ASTM A1003 ST50H, Grade 50 (340MPa)  
 minimum yield strength, 65 ksi (450 Mpa)  
 minimum tensile strength, material  
 thickness = 68mil (14gauge,  
 0.0713" design thickness)  
 G90 (Z275) hot-dipped  
 galvanized coating.

Header/Sill  
 Flange Width (+1/8")

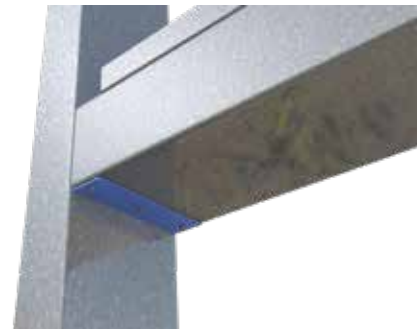
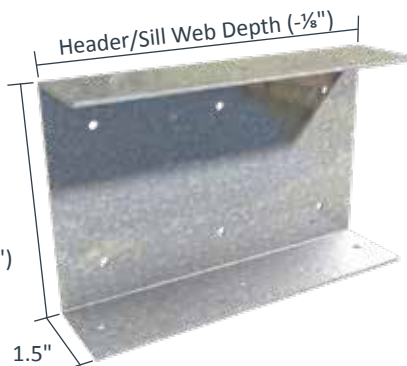

### StiffClip HS Allowable Loads

StiffClip® HS Recommended Allowable Load (lbs): F2 & F3 Load Direction						
Screw Patterns with #10 Screws	F2 Allowable Loads			F3 Allowable Loads		
	HS362	HS600	HS800	HS362	HS600	HS800
	4 Screws	6 Screws	6 Screws	4 Screws	6 Screws	6 Screws
33mil (20ga), 33ksi Stud	274	510	609	708	1,062	1,062
33mil (20ga), 50ksi Stud	395	734	877	795	1,161	1,455
43mil (18ga), 33ksi Stud	374	704	852	771	1,137	1,431
43mil (18ga), 50ksi Stud	542	1,019	1,233	869	1,235	1,529
54mil (16ga), 33ksi Stud	489	929	1,137	827	1,193	1,487
54mil (16ga), 50ksi Stud	707	1,342	1,642	949	1,315	1,609
68mil (14ga), 50ksi Stud	827	1,542	1,851	1,051	1,417	1,711
97mil (12ga), 50ksi Stud	1,017	1,835	2,131	1,265	1,631	1,925
118mil (10ga), 50ksi Stud	1,126	1,993	2,192	1,421	1,787	2,081

Load Direction

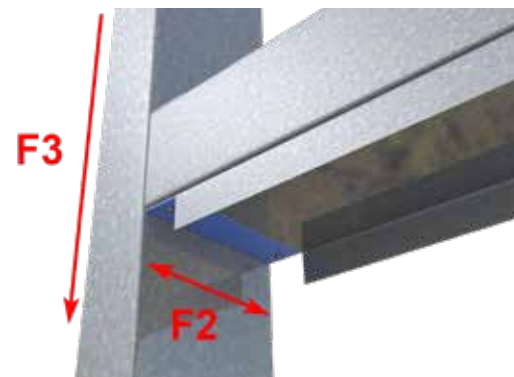

### Notes:

- Design loads are for attachment of StiffClip HS to the jamb. Use minimum (4) #10 screws for the attachment of the clip to the header or sill. Load tables reflect horizontal loads (F2) and vertical loads (F3).
- Design loads consider loads on the clip and #10 screw fasteners to the jamb web.
- Loads listed reflect force in a single direction. When multiple loads react on the connection, it is the responsibility of the designer to check the interaction of forces.
- Up to 1/4" gap is allowed between the jamb and the end of the header/sill member.
- Allowable loads apply to 250, 300, and 350 flange sizes.
- Allowable loads have not been increased for wind, seismic, or other factors.
- For LRFD strengths contact TSN technical services.

### Nomenclature

StiffClip HS is available for attachment to 3 5/8", 6", or 8" jambs, and for use with JamStuds with 2 1/2", 3" or 3 1/2" flanges. To specify, multiply jamb width and header flange width by 100.

**Example:** 6" jamb and a header flange width of 2 1/2"

**Designate:** StiffClip® HS600-250

### Example Details

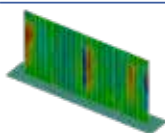

StiffClip HS Series  
 Blast and Seismic Design Data  
 www.steelnetwork.com

\*\* For more information or to review a copy of this report, please visit our website at <http://www.steelnetwork.com/light-steel-framing-design-resources>

# StiffClip® HC

Hip Connector

### Material Composition

ASTM A1003/A1003M Structural Grade 50 (340) Type H, ST50H (ST340H): 50ksi (340MPa) minimum yield strength, 65ksi (450MPa) minimum tensile strength, with ASTM A653/A653M G90 (Z275) hot dipped galvanized coating.

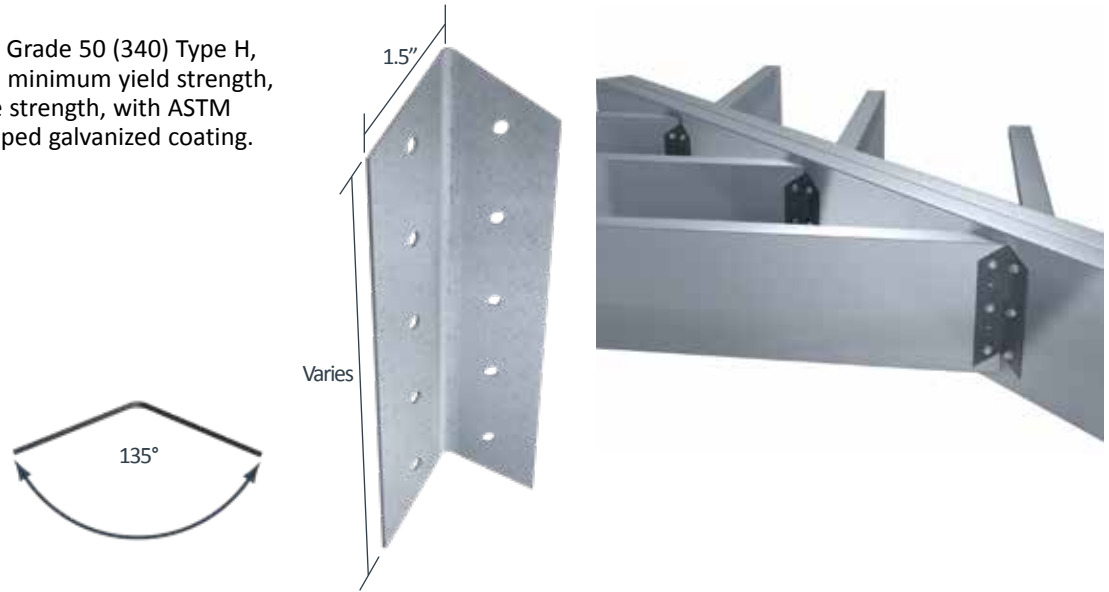

### StiffClip HC Allowable Loads

StiffClip® HC Recommended Allowable Load for a Single Clip (lbs): F3 Load Direction								
Screw Patterns with #12 Screws	HC362/400-43	HC362/400-68	HC600-43	HC600-68	HC800-43	HC800-68	HC1000-68	
	2 Screws	2 Screws	4 Screws	4 Screws	5 Screws	5 Screws	4 Screws	6 Screws
33mil (20ga), 33ksi Stud	337	336	720	720	909	909	N / A	N / A
33mil (20ga), 50ksi Stud	487	487	1,042	1,042	1,315	1,315	N / A	N / A
43mil (18ga), 33ksi Stud	501	501	1,073	1,073	1,353	1,353	1,100	1,643
43mil (18ga), 50ksi Stud	725	724	1,552	1,552	1,958	1,958	1,591	2,376
54mil (16ga), 33ksi Stud	736	705	1,575	1,510	1,987	1,904	1,548	2,312
54mil (16ga), 50ksi Stud	864	1,018	2,158	2,180	2,714	2,750	2,235	3,338
68mil (14ga), 50ksi Stud	864	1,283	2,158	2,747	2,714	3,466	2,816	4,207
97mil (12ga), 50ksi Stud	864	1,283	2,158	2,747	2,714	3,466	2,816	4,207
<b>Max Allowable Clip Load</b>	<b>864</b>	<b>1,392</b>	<b>2,158</b>	<b>3,639</b>	<b>2,714</b>	<b>5,062</b>	<b>5,062</b>	

Screw Patterns with #12 Screws	HC1200-68		HC1400-68		HC1600-68	
	6 Screws	8 Screws	5 Screws	9 Screws	6 Screws	10 Screws
54mil (16ga), 33ksi Stud	2,341	3,109	1,955	3,507	2,345	3,904
54mil (16ga), 50ksi Stud	3,381	4,490	2,823	4,560	3,387	4,560
68mil (14ga), 50ksi Stud	4,260	4,560	3,557	4,560	4,560	4,560
97mil (12ga), 50ksi Stud	4,260	4,560	3,557	4,560	4,560	4,560
<b>Max Allowable Clip Load</b>	<b>4,560</b>		<b>4,560</b>		<b>4,560</b>	

### Notes:

1. Design loads are for attachment of StiffClip HC to cold formed framing only. Load tables reflect vertical loads (F3).
2. Design loads consider loads on the clip and #12 screw fasteners in each leg.
3. Torsional effects are considered on screw group for F3 allowable loads. It is assumed that half of the torsional moment is taken by screw group in each leg of clip.
4. Allowable loads have not been increased for wind, seismic, or other factors.
5. For LRFD strengths contact TSN technical services.

### Nomenclature

StiffClip HC is designated by multiplying rafter depth by 100, then listing material thickness.

**Example:** 6" rafter depth, 68mil steel thickness

**Designate:** StiffClip® HC600-68

\*\*Standard angle bend is 135°. Other bend angles are available.

### Load Direction



# StiffClip® RT

Roof Tie



### Material Composition

**33 mil & 43 mil thicknesses:** ASTM A1003/A1003M Structural Grade 50 (340) Type H, ST50H (ST340H): 50ksi (340MPa) minimum yield strength, 65ksi (450MPa) minimum tensile strength, with ASTM A653/A653M G60 (Z180) hot dipped galvanized coating.

**54 mil thickness:** ASTM A1003/A1003M Structural Grade 50 (340) Type H, ST50H (ST340H): 50ksi (340MPa) minimum yield strength, 65ksi (450MPa) minimum tensile strength, with ASTM A653/A653M G90 (Z275) hot dipped galvanized coating.

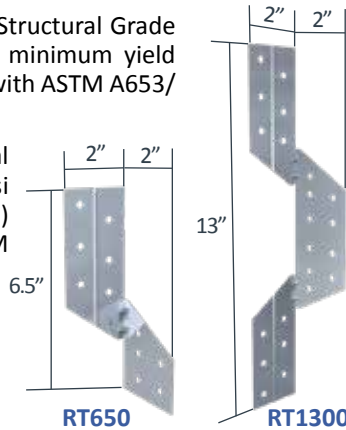

### StiffClip RT Allowable Loads

StiffClip® RT, Recommended Allowable Load (lbs): F1 Load Direction						
Screw Patterns with #12 Screws	RT650-33 & RT1300-33		RT650-43 & RT1300-43		RT650-54 & RT1300-54	
	w/2 #12 Screws	w/4 #12 Screws	w/2 #12 Screws	w/4 #12 Screws	w/2 #12 Screws	w/4 #12 Screws
33mil (20ga), 33ksi Stud	93	165	93	177	93	177
33mil (20ga), 50ksi Stud	135	165	135	184	135	256
43mil (18ga), 33ksi Stud	124	165	124	184	124	248
43mil (18ga), 50ksi Stud	165	165	179	184	179	342
54mil (16ga), 33ksi Stud	153	165	156	184	156	312
54mil (16ga), 50ksi Stud	165	165	184	184	225	342
68mil (14ga), 50ksi Stud	165	165	184	184	284	342
97mil (12ga), 50ksi Stud	165	165	184	184	342	342
<b>Max Allowable Clip Load</b>	<b>165</b>		<b>184</b>		<b>342</b>	

StiffClip® RT, Recommended Allowable Load (lbs): F2 Load Direction									
Screw Patterns with #12 Screws	RT650-33	RT650-33 & RT1300-33		RT650-43	RT650-43 & RT1300-43		RT650-54	RT650-54 & RT1300-54	
	5 Screws in Short Leg	2 Screws	4 Screws	5 Screws in Short Leg	2 Screws	4 Screws	5 Screws in Short Leg	2 Screws	4 Screws
33mil (20ga), 33ksi Stud	163	95	101	163	95	126	163	95	190
33mil (20ga), 50ksi Stud	236	101	101	236	126	126	236	138	276
43mil (18ga), 33ksi Stud	239	101	101	243	124	126	243	124	248
43mil (18ga), 50ksi Stud	239	101	101	329	126	126	351	179	327
54mil (16ga), 33ksi Stud	239	101	101	312	126	126	312	156	312
54mil (16ga), 50ksi Stud	239	101	101	329	126	126	450	225	327
68mil (14ga), 50ksi Stud	239	101	101	329	126	126	568	284	327
97mil (12ga), 50ksi Stud	239	101	101	329	126	126	614	327	327
<b>Max Allowable Clip Load</b>	<b>239</b>	<b>101</b>		<b>329</b>	<b>126</b>		<b>614</b>	<b>327</b>	

**\*\*StiffClip RT Allowable Load tables and important notes continued on next page.**

StiffClip® RT, Recommended Allowable Load (lbs): F3						
Screw Patterns with #12 Screws	RT650-33 & RT1300-33		RT650-43 & RT1300-43		RT650-54 & RT1300-54	
	2 Screws	4 Screws	2 Screws	4 Screws	2 Screws	4 Screws
33mil (20ga), 33ksi Stud	198	358	198	383	198	383
33mil (20ga), 50ksi Stud	286	358	286	386	286	554
43mil (18ga), 33ksi Stud	320	358	295	386	295	570
43mil (18ga), 50ksi Stud	358	358	386	386	426	809
54mil (16ga), 33ksi Stud	358	358	386	386	415	802
54mil (16ga), 50ksi Stud	358	358	386	386	599	809
68mil (14ga), 50ksi Stud	358	358	386	386	753	809
97mil (12ga), 50ksi Stud	358	358	386	386	753	809
<b>Maximum Allowable Clip Load</b>	<b>358</b>		<b>386</b>		<b>809</b>	

**Notes:**

- Design loads are for attachment of StiffClip RT to light gauge framing members only. Load tables reflect in plane of wall loads (F1), horizontal loads (F2) and vertical uplift loads (F3).
- Number of screws designated represent the amount of #12 screws required in each leg of clips.
- Loads listed reflect force in a single direction. When multiple loads react on the connection, it is the responsibility of the designer to check the interaction of forces.
- Torsional effects are considered on screw groups for F1, F2, and F3 allowable loads. It is assumed that half of the torsional moment is taken by the connection to the structure and half is taken by the connection to the stud.
- Allowable loads have not been increased for wind, seismic, or other factors.
- StiffClip RT650 is available in a Left version and Right version. Contact TSN for ordering assistance.
- For LRFD strengths contact TSN technical services.

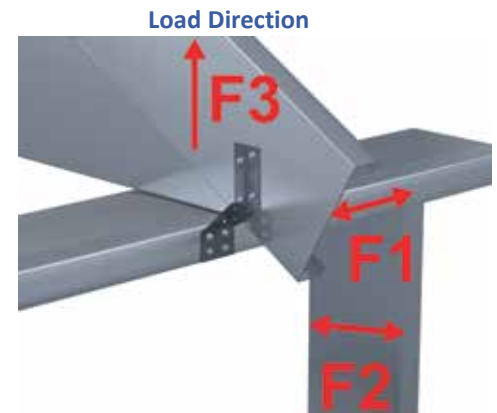

**Nomenclature**

StiffClip RT650 is 6½” long, and may be used when wall studs do not align with roof framing member. The RT1300 is 13” long, and is used when wall studs align with roof framing member. Clips are designated by length, followed by thickness and number of screws used in each leg (determined by load requirements - refer to load tables).

**Example:** Stud aligns with roof framing member (see application image)

**Designate:** StiffClip® 1300

\* StiffClip RT650 are packaged in pairs.



# StiffClip® WC

Web Connector

### Material Composition

**54mil:** ASTM A1003/A1003M Structural Grade 50 (340) Type H, ST50H (ST340H): 50ksi (340MPa) minimum yield strength, 65ksi (450MPa) minimum tensile strength, 54mil minimum thickness (16 gauge, 0.0566" design thickness) with ASTM A653/A653M G90 (Z275) hot dipped galvanized coating.

**118mil:** ASTM A1003/A1003M Structural Grade 50 (340) Type H, ST50H (ST340H): 50ksi (340MPa) minimum yield strength, 65ksi (450MPa) minimum tensile strength, 118mil minimum thickness (10 gauge, 0.1242" design thickness) with ASTM A653/A653M G90 (Z275) hot dipped galvanized coating.

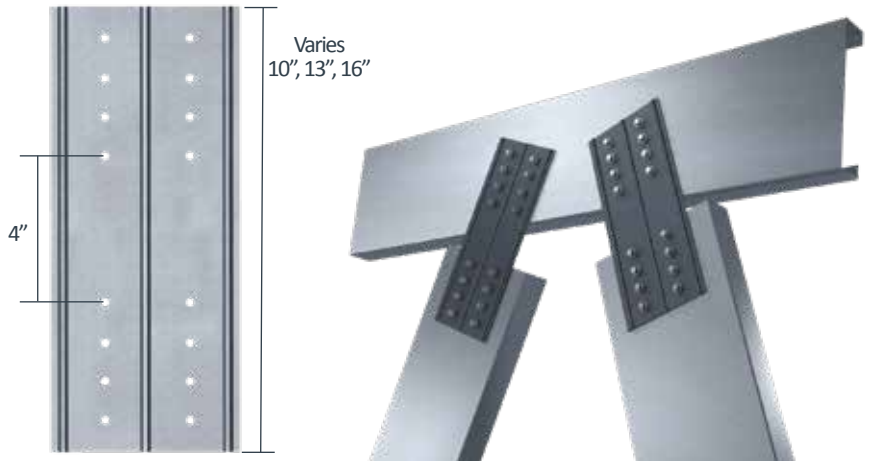

Tension / Compression Load Direction												
Screw Patterns with #12 Screw	WC350-54, 10" Length				WC350-118, 10" Length				WC550-54, 13" Length			
	2 Screws	4 Screws	6 Screws	8 Screws	2 Screws	4 Screws	6 Screws	8 Screws	4 Screws	6 Screws	8 Screws	10 Screws
33mil (20ga), 33ksi stud	104	153	248	1,300	376	752	1,128	1,504	118	184	327	737
33mil (20ga), 50ksi stud	104	153	248	1,300	544	1,088	1,632	2,176	118	184	327	737
43mil (18ga), 33ksi stud	104	153	248	1,300	560	1,120	1,680	2,240	118	184	327	737
43mil (18ga), 50ksi stud	104	153	248	1,300	810	1,618	2,430	3,240	118	184	327	737
54mil (16ga), 33ksi stud	104	153	248	1,300	788	1,576	2,364	3,152	118	184	327	737
54mil (16ga), 50ksi stud	104	153	248	1,300	1,097	1,618	2,620	4,552	118	184	327	737
68mil (14ga), 50ksi stud	104	153	248	1,300	1,097	1,618	2,620	4,936	118	184	327	737
97mil (12ga), 50ksi stud	104	153	248	1,300	1,097	1,618	2,620	4,936	118	184	327	737
<b>Max Allowable Clip Load</b>	<b>1,300*</b>				<b>4,936**</b>				<b>737**</b>			

Screw Patterns with #12 Screw	WC550-118, 13" Length				WC750-54, 16" Length					WC750-118, 16" Length				
	4 Screws	6 Screws	8 Screws	10 Screws	4 Screws	6 Screws	8 Screws	10 Screws	12 Screws	4 Screws	6 Screws	8 Screws	10 Screws	12 Screws
33mil (20ga), 33ksi stud	752	1,128	1,504	1,880	112	161	251	447	1,005	752	1,128	1,504	1,880	2,256
33mil (20ga), 50ksi stud	1,088	1,632	2,176	2,720	112	161	251	447	1,005	1,088	1,632	2,176	2,720	3,264
43mil (18ga), 33ksi stud	1,120	1,680	2,240	2,800	112	161	251	447	1,005	1,120	1,680	2,240	2,800	3,360
43mil (18ga), 50ksi stud	1,246	1,946	3,240	4,050	112	161	251	447	1,005	1,180	1,699	2,654	4,050	4,860
54mil (16ga), 33ksi stud	1,246	1,946	3,152	3,940	112	161	251	447	1,005	1,180	1,699	2,654	3,940	4,728
54mil (16ga), 50ksi stud	1,246	1,946	3,460	5,690	112	161	251	447	1,005	1,180	1,699	2,654	4,718	6,828
68mil (14ga), 50ksi stud	1,246	1,946	3,460	7,756	112	161	251	447	1,005	1,180	1,699	2,654	4,718	9,324
97mil (12ga), 50ksi stud	1,246	1,946	3,460	7,756	112	161	251	447	1,005	1,180	1,699	2,654	4,718	9,324
<b>Max Allowable Clip Load</b>	<b>7,756**</b>				<b>1,005**</b>					<b>10,576**</b>				

### Table Notes:

- Design loads are for attachment of StiffClip WC to light gauge framing members only. Allowable load tables apply to tension and compression on StiffClip WC utilizing the fastener patterns shown on the next page.
  - All guide holes may not require fasteners. Number and size of fasteners used is based on fastener manufacturer's allowable load data, and is to be verified by the designer.
  - Allowable loads have not been increased for wind, seismic, or other factors.
  - For LRFD strengths contact TSN technical services.
- \* Maximum allowable load is based on structural testing.  
 \*\* Maximum allowable load is based on calculations.

### Load Direction



\*\*\*StiffClip WC Screw Patterns are shown on next page.

**Screw Patterns**

**WC350-54**

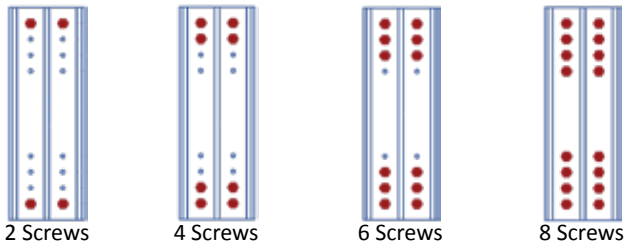

**WC350-118**

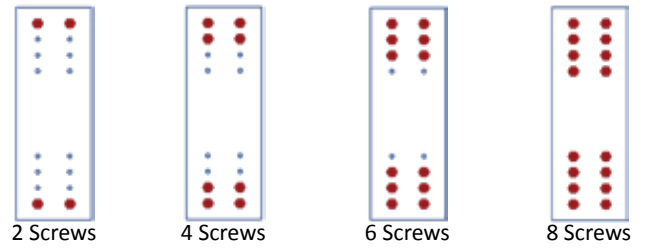

**WC550-XX**

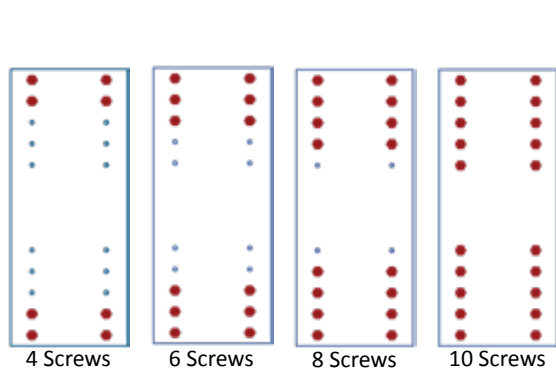

**WC750-XX**

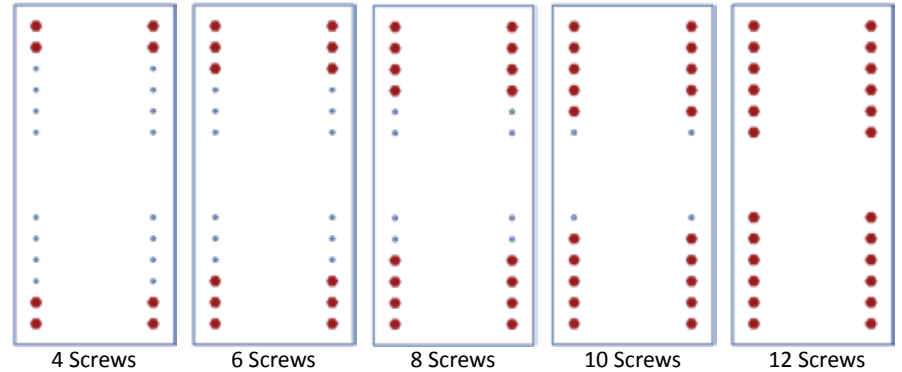

**Nomenclature**

StiffClip WC is designated by multiplying truss web stud depth in inches by 100, then listing material, thickness and length.

**Example:** 3½" truss web stud depth, 54mil steel thickness, 10" long

**Designate:** StiffClip® WC350-54 10"

**Example Details**



# StiffClip® PL

Truss Plate Connector



### Material Composition

ASTM A1003/A1003M Structural Grade 50 (340) Type H, ST50H (ST340H): 50ksi (340MPa) minimum yield strength, 65ksi (450MPa) minimum tensile strength, with ASTM A653/A653M G90 (Z275) hot dipped galvanized coating.



### StiffClip PL Allowable Loads

Plates used to connect framing are generally considered as pinned joints. Load transfers through screw or welded connections between members.

#### Notes:

- All guide holes may not require fasteners. Number and size of fasteners used is based on fastener manufacturer's allowable load data, and is to be verified by designer.
- Guide holes are 0.172" in diameter unless specified.
- Guide holes have ½" minimum edge distance and 1" minimum spacing. Spacing will vary based on plate size and specified project requirements.

### Nomenclature

StiffClip PL is available in many different shapes and is designated as width x length - material thickness.

**Example:** 10" wide x 24" long with 68 mil thickness

**Designate:** StiffClip® PL10x24-68

\* Plate sizes vary within each application

\*\*StiffClip PL are typically made to order per project specifications.

### Load Directions

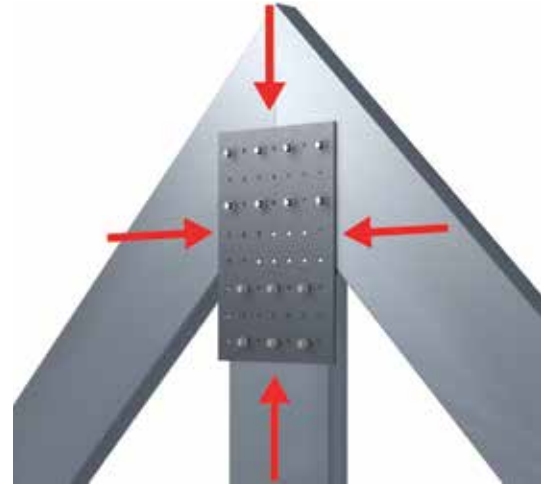

### Example Details

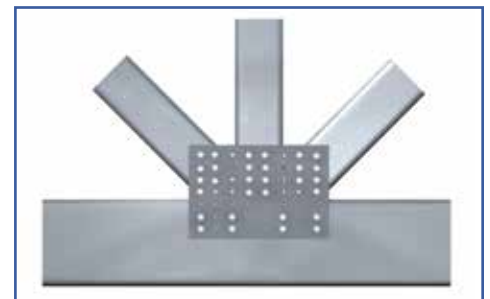
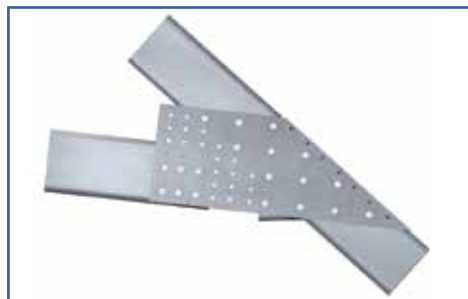
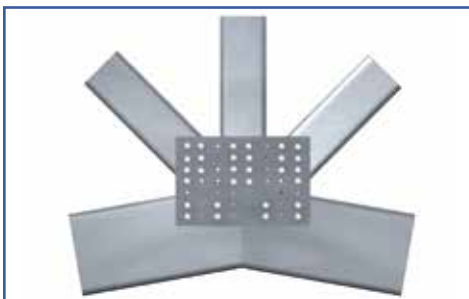
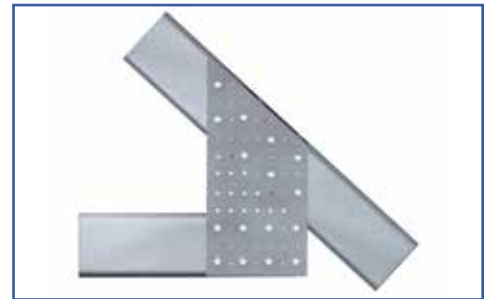
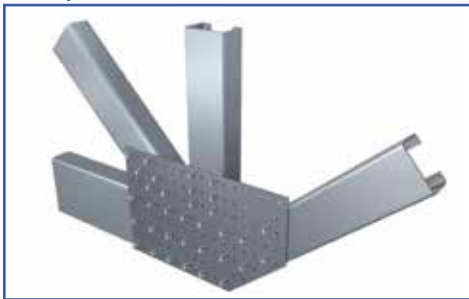

# StiffClip® JH

Joist Hanger

### Material Composition

ASTM A1003/A1003M Structural Grade 50 (340) Type H, ST50H (ST340H): 50ksi (340MPa) minimum yield strength, 65ksi (450MPa) minimum tensile strength, with ASTM A653/A653M G90 (Z275) hot dipped galvanized coating.

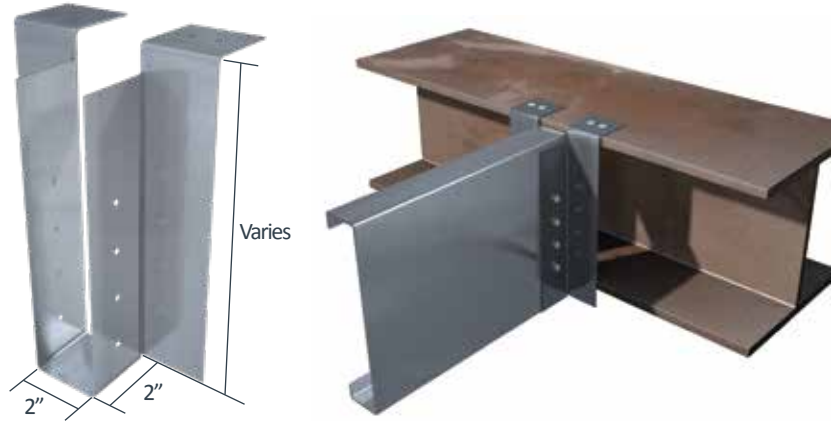

### StiffClip JH Allowable Loads

StiffClip® JH Recommended Allowable Load (lbs): F3 Load Direction						
Screw Patterns with #12 Screws	JH600-68	JH800-68	JH1000-68	JH1000-97	JH1200-68	JH1200-97
	2 Screws	3 Screws	4 Screws	4 Screws	5 Screws	5 Screws
33mil (20ga), 33ksi Stud	638	474	377	377	313	313
33mil (20ga), 50ksi Stud	638	474	377	377	313	313
43mil (18ga), 33ksi Stud	1,416	1,051	836	836	694	694
43mil (18ga), 50ksi Stud	1,416	1,051	836	836	694	694
54mil (16ga), 33ksi Stud	2,575	2,091	1,661	1,661	1,377	1,377
54mil (16ga), 50ksi Stud	2,575	2,091	1,661	1,661	1,377	1,377
68mil (14ga), 33ksi Stud	2,575	2,575	2,575	3,345	2,575	2,771
68mil (14ga), 50ksi Stud	2,575	2,575	2,575	3,345	2,575	2,771
97mil (12ga), 33ksi Stud	2,575	2,575	2,575	4,167	2,575	4,167
97mil (12ga), 50ksi Stud	2,575	2,575	2,575	4,167	2,575	4,167
118mil (10ga), 50ksi Stud	2,575	2,575	2,575	4,167	2,575	4,167
<b>Max Allowable Clip Load</b>	<b>2,575</b>	<b>2,575</b>	<b>2,575</b>	<b>4,167</b>	<b>2,575</b>	<b>4,167</b>

### Notes:

1. Design loads are for attachment of StiffClip JH to joist only. Load tables reflect vertical loads (F3).
2. StiffClip JH resists vertical loads and web crippling.
3. Design loads are based on clip capacity and allowable shear of joist section.
4. Screw size and quantity shown is required for StiffClip JH to serve as a joist web stiffener.
5. If joist web is larger than clip height then use blocking behind clip for support.
6. Allowable loads have not been increased for wind, seismic, or other factors.
7. Screws, powder actuated fasteners, or weld attachment may be used to connect StiffClip JH to steel headers or beams. StiffClip JH-68 and heavier can be welded to a supporting steel beam. Powder actuated fasteners into steel are recommended to be 0.157" diameter, and are limited to a maximum of 3/4" substrate thickness.
8. For LRFD strengths contact TSN technical services.



Load Direction

### Nomenclature

StiffClip JH is designated by listing the joist depth in inches, followed by the inside flange dimension in inches x 100 (2" flange is standard, and will also service 1 5/8" flange), and the required clip thickness in mils that will accommodate anticipated loads. (see load tables)

**Example:** 6" joist, 2" flange, 2,250 lbs. load  
**Designate:** StiffClip® JH600x200-68

# StiffClip® JC

Joist Connector



### Material Composition

ASTM A1003/A1003M Structural Grade 50 (340) Type H, ST50H (ST340H): 50ksi (340MPa) minimum yield strength, 65ksi (450MPa) minimum tensile strength, with ASTM A653/A653M G90 (Z275) hot dipped galvanized coating.

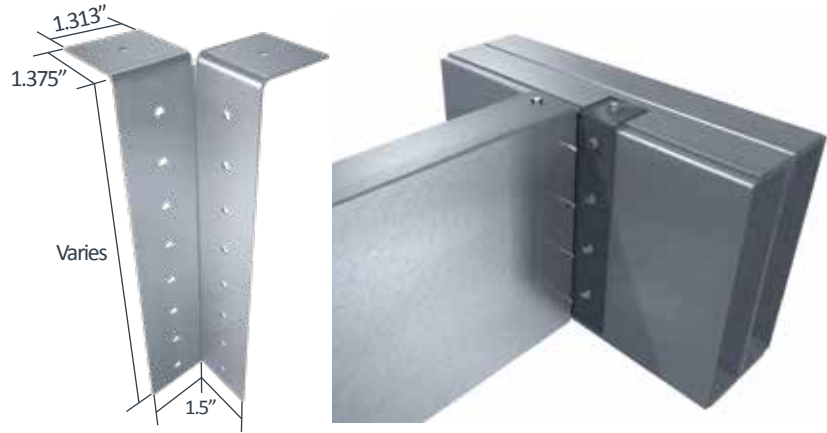

### StiffClip JC Allowable Loads

StiffClip® JC Recommended Allowable Load (lbs): F3 Load Direction												
Screw Patterns with #12 Screws	JC362/400-43	JC362/400-68	JC600-43		JC600-68		JC800-43		JC800-68		JC1000-68	
	3 Screws	3 Screws	3 Screws	5 Screws	3 Screws	5 Screws	4 Screws	7 Screws	4 Screws	7 Screws	5 Screws	9 Screws
33mil (20ga), 33ksi Stud	564	564	543	880	543	880	734	1,267	734	1,267	924	1,651
33mil (20ga), 50ksi Stud	816	816	786	1,273	786	1,273	1,061	1,833	1,061	1,833	1,337	2,388
43mil (18ga), 33ksi Stud	836	840	809	1,311	809	1,311	1,093	1,887	1,093	1,887	1,376	2,459
43mil (18ga), 50ksi Stud	836	1,215	1,170	1,896	1,170	1,896	1,580	2,729	1,580	2,729	1,990	3,556
54mil (16ga), 33ksi Stud	836	1,182	1,187	1,924	1,138	1,845	1,604	2,770	1,538	2,655	1,936	3,460
54mil (16ga), 50ksi Stud	836	1,482	1,646	2,158	1,643	2,664	2,224	3,220	2,220	3,834	2,796	4,996
68mil (14ga), 50ksi Stud	836	1,482	1,646	2,158	2,071	3,357	2,224	3,220	2,798	4,617	3,524	5,062
97mil (12ga), 50ksi Stud	836	1,482	1,646	2,158	2,071	3,357	2,224	3,220	2,798	4,617	3,524	5,062
<b>Max Allowable Clip Load</b>	<b>836</b>	<b>1,482</b>	<b>2,158</b>		<b>3,639</b>		<b>3,220</b>		<b>4,617</b>		<b>5,062</b>	

StiffClip® JC Recommended Allowable Load (lbs): F3 Load Direction						
Screw Patterns with #12 Screws	JC1200-68		JC1400-68		JC1600-68	
	w/6 #12 screws	w/11 #12 screws	w/7 #12 screws	w/13 #12 screws	w/8 #12 screws	w/15 #12 screws
54mil (16ga), 33ksi Stud	2,334	4,260	2,731	5,057	3,128	5,649
54mil (16ga), 50ksi Stud	3,371	5,649	3,944	5,649	4,517	5,649
68mil (14ga), 50ksi Stud	4,247	5,649	4,970	5,649	5,649	5,649
97mil (12ga), 50ksi Stud	4,247	5,649	4,970	5,649	5,649	5,649
<b>Max Allowable Clip Load</b>	<b>5,649</b>		<b>5,649</b>		<b>5,649</b>	

### Notes:

1. Design loads are for attachment of StiffClip JC to joist only. Load tables reflect vertical loads (F3).
2. Design loads consider clip capacity and screw connection to the joist only.
3. All guide holes may not require fasteners. Fastener size and quantity determined by designer.
4. Torsional effects are considered on screw group for F3 allowable loads. It is assumed that half of the torsional moment is resisted by the connection to the structure and half is resisted by the connection to the joist.
6. Allowable loads have not been increased for wind, seismic, or other factors.
7. StiffClip JC attachment to the beam or structure must be designed to be greater than or equivalent to the joist attachment.
8. For LRFD strengths contact TSN technical services.

### Nomenclature

StiffClip JC is designated by listing the joist depth in inches, followed by the required clip thickness in mils that will accommodate anticipated loads. (see load tables above)

**Example:** 6" joist, 3,000 lbs. load  
**Designate:** StiffClip® JC600-68

### Load Direction

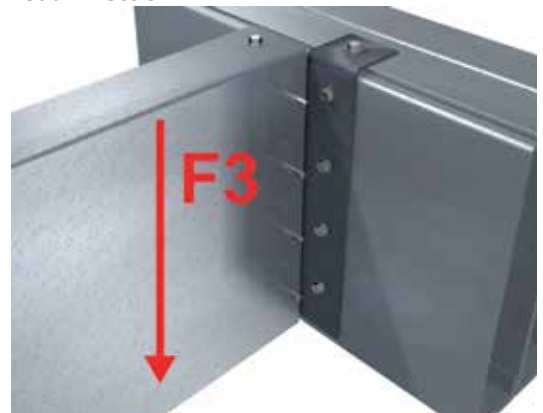

# StiffClip® FS

Floor Strap

### Material Composition

ASTM A1003/A1003M Structural Grade 50 (340) Type H, ST50H (ST340H): 50ksi (340MPa) minimum yield strength, 65ksi (450MPa) minimum tensile strength, with ASTM A653/A653M G90 (Z275) hot dipped galvanized coating.

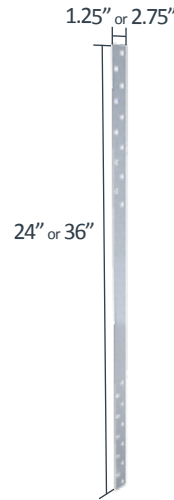

### StiffClip FS Allowable Loads

StiffClip® FS Recommended Allowable Load (lbs): F3 Tension Load Direction	
Designation	Load
FS125-33	1,163
FS125-43	1,516
FS125-54	1,902
FS125-68	2,396
FS125-97	3,418
FS275-33	2,849
FS275-43	3,713
FS275-54	4,660
FS275-68	5,871
FS275-97	8,374

### Load Direction



### Notes:

1. Design loads are based on strap capacity only. StiffClip FS resists tension forces only.
2. Number of fasteners used is based on fastener manufacturer's allowable load data.
3. Guide holes are located 1/2" from each end, with 3/8" edge distance at 2" o.c. staggered for FS125 and 3/4" edge distance at 2" o.c. staggered for FS275.
4. Allowable loads have not been increased for wind, seismic, or other factors.
5. For LRFD strengths contact TSN technical services.

### Nomenclature

StiffClip FS is designated by the width of the strap in inches followed by strap thickness in mils.

**Example:** 16ga, 2¼" strap, 24" long

**Designate:** StiffClip® FS275-54-24

\* Additional guide holes for fasteners available upon request.

\*\*StiffClip FS are typically made to order per project specifications.

# StiffClip® AL

Multi-Directional Load Resistant Angle

## Material Composition

ASTM A1003/A1003M Structural Grade 50 (340) Type H, ST50H (ST340H): 50ksi (340MPa) minimum yield strength, 65ksi (450MPa) minimum tensile strength, 68mil minimum thickness (14 gauge, 0.0713" design thickness) with ASTM A653/A653M G90 (Z275) hot dipped galvanized coating.

The attachment of StiffClip to the primary structure may be made with PAFs, screw/bolt anchors or weld and is dependent upon the base material (steel or concrete) and the design configuration.



The Steel Network, Inc.   
www.steelnetwork.com  
1-888-474-4876



## StiffClip AL Allowable Loads

StiffClip® AL, Recommended Allowable Load (lbs): F1 Load Directions									
Screw Patterns with #12 Screws	AL362			AL600			AL800		
	2 Screws	3 Screws	4 Screws	2 Screws	3 Screws	4 Screws	2 Screws	4 Screws	6 Screws
33mil (20ga), 33ksi Stud	95	190	190	95	190	190	95	190	285
33mil (20ga), 50ksi Stud	138	276	276	138	276	276	138	276	414
43mil (18ga), 33ksi Stud	124	248	248	124	248	248	124	248	372
43mil (18ga), 50ksi Stud	179	358	358	179	358	358	179	358	537
54mil (16ga), 33ksi Stud	156	312	312	156	312	312	156	312	468
54mil (16ga), 50ksi Stud	225	450	450	225	450	450	225	450	675
68mil (14ga), 50ksi Stud	284	568	568	284	568	568	284	568	852
97mil (12ga), 50ksi Stud	405	810	810	405	810	810	405	810	1,215
118mil (10ga), 50ksi Stud	494	975	975	494	866	866	494	988	1,482
<b>Max Allowable Clip Load</b>	<b>975</b>			<b>866</b>			<b>1,768</b>		

StiffClip® AL, Recommended Allowable Load (lbs): F2 Load Directions									
Screw Patterns with #12 Screws	AL362			AL600			AL800		
	2 Screws	3 Screws	4 Screws	2 Screws	3 Screws	4 Screws	2 Screws	4 Screws	6 Screws
33mil (20ga), 33ksi Stud	376	516	752	376	530	752	376	752	1,128
33mil (20ga), 50ksi Stud	544	747	1,088	544	767	1,088	544	1,088	1,632
43mil (18ga), 33ksi Stud	560	769	1,120	560	789	1,120	560	1,120	1,680
43mil (18ga), 50ksi Stud	810	1,112	1,470	810	1,142	1,620	810	1,620	2,430
54mil (16ga), 33ksi Stud	788	1,082	1,470	788	1,111	1,576	788	1,576	2,364
54mil (16ga), 50ksi Stud	1,138	1,470	1,470	1,138	1,604	2,091	1,138	2,276	2,516
68mil (14ga), 50ksi Stud	1,434	1,470	1,470	1,434	2,021	2,091	1,434	2,516	2,516
97mil (12ga), 50ksi Stud	1,434	1,470	1,470	1,434	2,021	2,091	1,434	2,516	2,516
118mil (10ga), 50ksi Stud	1,434	1,470	1,470	1,434	2,021	2,091	1,434	2,516	2,516
<b>Max Allowable Clip Load</b>	<b>1,470</b>			<b>2,091</b>			<b>2,516</b>		

StiffClip® AL, Recommended Allowable Load (lbs): F3 Load Directions									
Screw Patterns with #12 Screws	AL362			AL600			AL800		
	2 Screws	3 Screws	4 Screws	2 Screws	3 Screws	4 Screws	2 Screws	4 Screws	6 Screws
33mil (20ga), 33ksi Stud	255	407	510	324	495	648	345	690	985
33mil (20ga), 50ksi Stud	369	589	738	469	716	938	499	999	1,425
43mil (18ga), 33ksi Stud	380	606	760	483	737	965	514	1,028	1,467
43mil (18ga), 50ksi Stud	550	877	1,100	698	1,066	1,396	743	1,487	2,122
54mil (16ga), 33ksi Stud	535	853	1,070	679	1,037	1,358	723	1,446	2,064
54mil (16ga), 50ksi Stud	772	1,232	1,545	981	1,498	1,961	1,044	2,089	2,981
68mil (14ga), 50ksi Stud	973	1,553	1,947	1,236	1,888	2,471	1,316	2,632	3,756
97mil (12ga), 50ksi Stud	973	1,553	1,947	1,236	1,888	2,471	1,316	2,632	3,756
118mil (10ga), 50ksi Stud	973	1,553	1,947	1,236	1,888	2,471	1,316	2,632	3,756
<b>Max Allowable Clip Load</b>	<b>2,458</b>			<b>3,015</b>			<b>6,128</b>		



**\*\*Important notes for StiffClip AL Allowable Load tables continued on next page.**

**Notes:**

1. StiffClip AL is tested to resist loads in horizontal, vertical, and lateral directions.
2. Allowable load tables incorporate eccentric loading of fasteners attached 3/4" from the heel of the clip. Values with welded connection may increase.
3. Allowable loads are for attachment through 3" leg only. Attachment through 1-1/2" leg should be engineered. Reference Material Composition above for calculation purposes.
4. Loads listed reflect force in a single direction. When multiple loads react on the connection, it is the responsibility of the designer to check the interaction of forces.
5. Torsional effects are considered on screw group for F2 and F3 allowable loads. It is assumed that half of the torsional moment is taken by the connection in the short leg and half is taken by the connection in the long leg of StiffClip AL.
6. Allowable loads have not been increased for wind, seismic, or other factors.
7. All guide holes may not require fasteners. Number of fasteneres used is to be determined by designer.
8. Stiffening ribs are not present in StiffClip AL800.
9. For LRFD strengths contact TSN technical services.

**Screw Patterns**

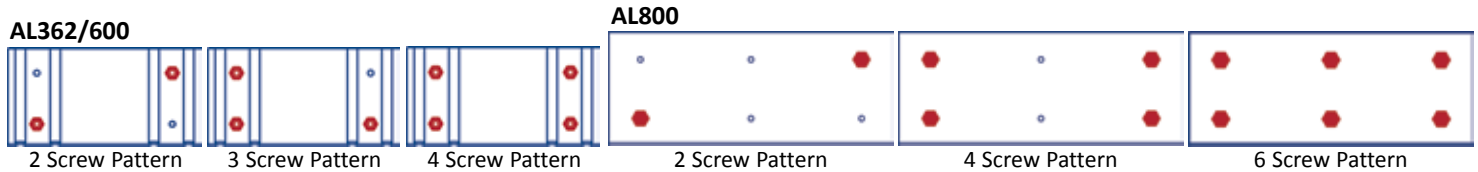

**Nomenclature**

StiffClip AL is available for various stud depths. To specify, multiply stud depth by 100.\*

**Example:** 6" stud depth

**Designate:** StiffClip® AL600

\* The AL362 fits 3 5/8" and 4" member depths

\*\* Stiffening ribs are not present in the AL800.

**Example Details**

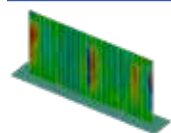
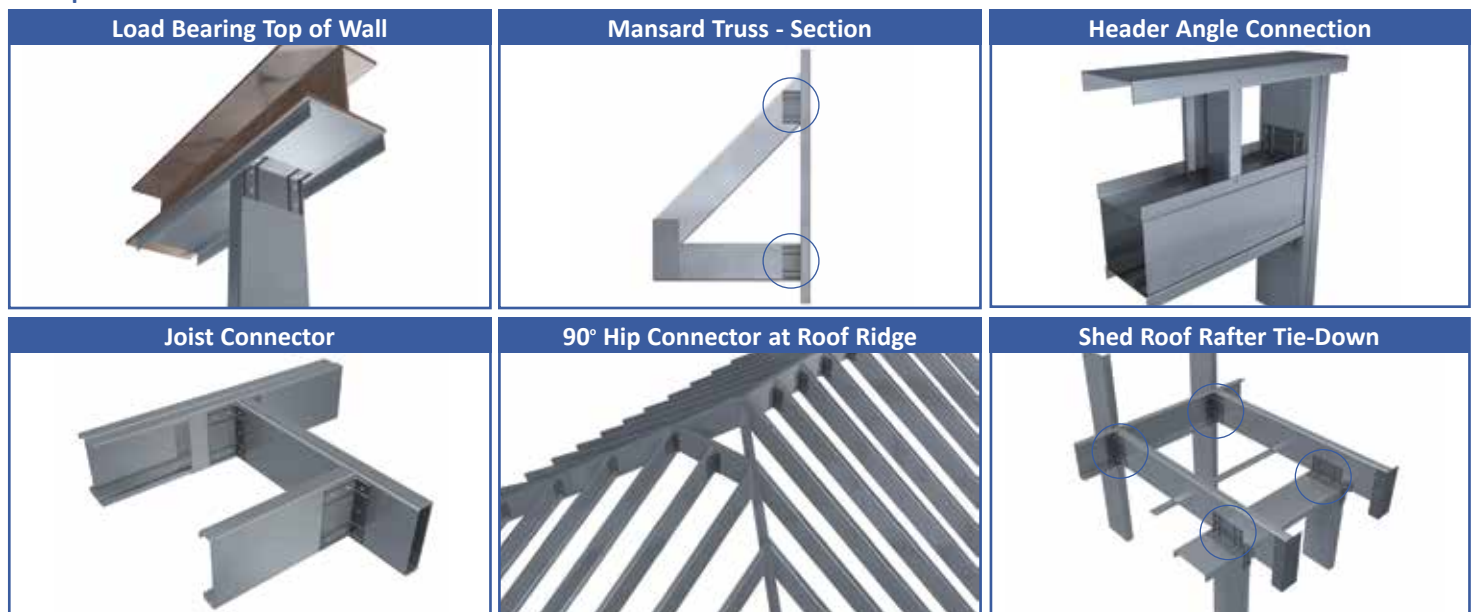

StiffClip HE Series  
Blast and Seismic Design Data  
www.steelnetwork.com

\*\* For more information or to review a copy of this report, please visit our website at <http://www.steelnetwork.com/light-steel-framing-design-resources>

# StiffClip® LS

Spandrel/Multi-Purpose



### Material Composition

ASTM A1003/A1003M Structural Grade 50 (340) Type H, ST50H (ST340H): 50ksi (340MPa) minimum yield strength, 65ksi (450MPa) minimum tensile strength, 68mil minimum thickness (14 gauge, 0.0713" design thickness) with ASTM A653/A653M G90 (Z275) hot dipped galvanized coating.

The attachment of StiffClip to the primary structure may be made with PAFs, screw/bolt anchors or weld and is dependent upon the base material (steel or concrete) and the design configuration.

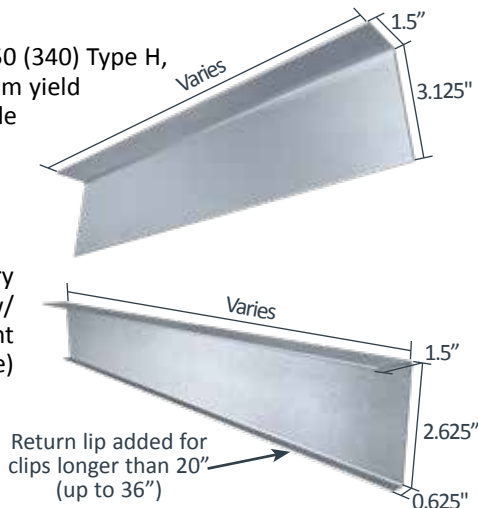

### Material Analysis

StiffClip® LS Section Properties							
Designation	Area (in <sup>2</sup> )	I <sub>x</sub> (in <sup>4</sup> )	I <sub>y</sub> (in <sup>4</sup> )	R <sub>x</sub> (in)*	R <sub>y</sub> (in)**	S <sub>x</sub> (in <sup>3</sup> )	S <sub>y</sub> (in <sup>3</sup> )
StiffClip® LS < 20" Length	0.322	0.341	0.057	1.029	0.419	0.168	0.046
StiffClip® LS > 20" Length	0.323	0.308	0.055	0.978	0.413	0.198	0.046

### Notes:

1. StiffClip LS resists axial tension and ocmpression loads.
2. Allowable design loads may be calculated based on the section properties shown above.
3. Lengths greater than 20" incorporate a stiffening lip to increase compressive strength.
4. For powder actuated fasteners, fasten within 3/4" from the angle heel centerline of the 1-1/2" leg.

\* Rx = Radius of Gyration about x-x axis.  
 \*\* Ry = Radius of Gyration about y-y axis.

### Nomenclature

StiffClip LS is available in various lengths. To calculate length for spandrel wall connectors, add stud depth, 3" for attachment to steel (5.5" for attachment to concrete), and the distance of construction tolerance. For other applications, simply designate length (in.) multiplied by 100.

**Example:** 6" stud depth, 4" attachment to structure, 2" tolerance (6+4+2=12)  
**Designate:** StiffClip® LS1200

### Example Details

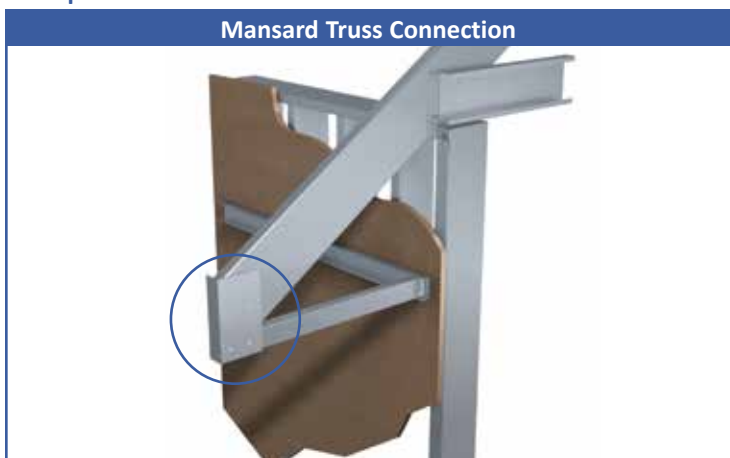

# CircleTrak®

Curved Wall Track

### Material Composition

ASTM A1003/A1003M Structural Grade 33 (230) Type H, ST33H (ST230H): 33ksi (230MPa) minimum yield strength, 45ksi (310MPa) minimum tensile strength, 33mil minimum thickness (20 gauge, 0.0346" design thickness) with ASTM A653/A653M G60 (Z180) hot dipped galvanized coating

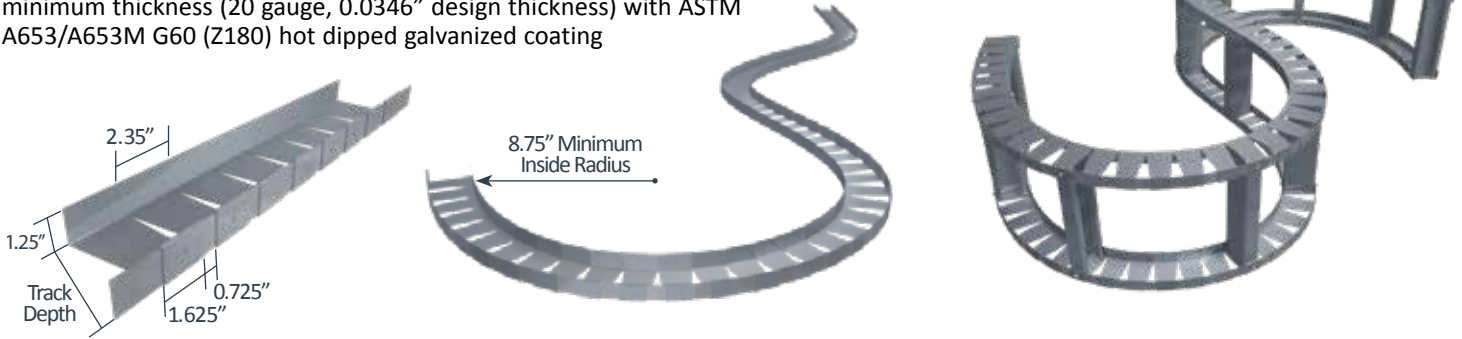

Product Designation	Thickness			
	Mils	Gauge	Design Thickness	
			in	mm
CircleTrak®	33	20	0.0346	0.878

### Nomenclature

CircleTrak is available in 10' lengths and is designated by inside web depth x 100, then style (CT), followed by leg length and then material thickness in mils. Circletrak comes in standard 2.5, 3.5, 3.625, 4, 5.5, and 6" web depths.

**Example:** 6" inside web depth

**Designate:** 600CT125-33

### Example Details



# NotchTrak® NT

Rigid Wall Backing & Bridging Alternative

The Steel Network, Inc.

www.steelnetwork.com

1-888-474-4876



## Material Composition

ASTM A1003/A1003M Structural Grade 50 (340) Type H, ST50H (ST340H): 50ksi (340MPa) minimum yield strength, 65ksi (450MPa) minimum tensile strength, with ASTM A653/A653M G60 (Z180) hot dipped galvanized coating, or equivalent.

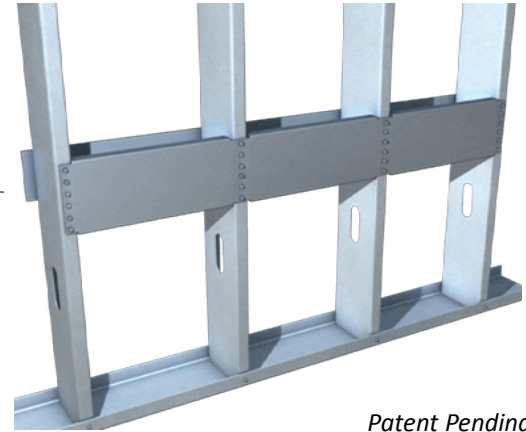
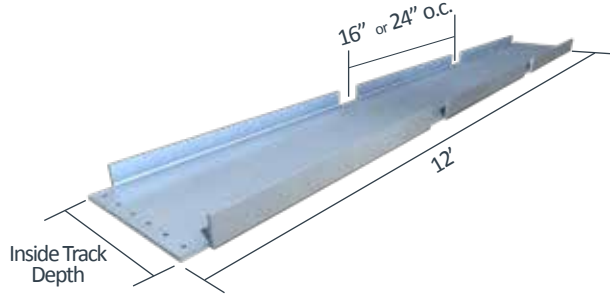

Patent Pending

## Material Analysis

NotchTrak® NT Section Properties																		
Designation	Gross Properties													Effective Properties 50 ksi				
	Area (Full)	Area (Notch)	$I_x$	$S_x$	$R_x$	$I_y$	$R_y$	$J \times 10^3$	$C_w$	$R_o$	$X_o$	$m$	$\beta$	$A_e$ (Full)	$I_x^1$	$S_x$	$M_{xa}$	$V_a$
	(in <sup>2</sup> )	(in <sup>2</sup> )	(in <sup>4</sup> )	(in <sup>3</sup> )	(in)	(in <sup>4</sup> )	(in)	(in <sup>4</sup> )	(in <sup>6</sup> )	(in)	(in)	(in)		(in <sup>2</sup> )	(in <sup>4</sup> )	(in <sup>3</sup> )	(lbs-in)	(lbs)
600NT125-43	0.383	0.262	1.861	0.604	2.205	0.044	0.337	0.260	0.307	2.289	-0.513	0.335	0.950	0.159	1.745	0.403	12,060	1,380
600NT125-54	0.480	0.329	2.345	0.757	2.209	0.054	0.335	0.513	0.384	2.292	-0.508	0.332	0.951	0.243	2.300	0.593	17,760	2,730
600NT125-68	0.605	0.414	2.971	0.951	2.216	0.067	0.332	1.025	0.483	2.296	-0.503	0.329	0.952	0.370	2.971	0.859	25,730	5,350
800NT125-43	0.473	0.352	3.773	0.925	2.824	0.046	0.311	0.321	0.589	2.874	-0.436	0.292	0.977	0.162	3.402	0.553	16,550	1,030
800NT125-54	0.594	0.442	4.747	1.158	2.828	0.057	0.309	0.634	0.735	2.877	-0.432	0.289	0.977	0.248	4.617	0.824	24,680	2,040
800NT125-68	0.748	0.557	6.001	1.455	2.833	0.070	0.307	1.267	0.920	2.882	-0.427	0.286	0.978	0.381	6.001	1.217	36,430	4,090

<sup>1</sup>Effective moment of inertia,  $I_x$ , is calculated at a stress level equal to 0.6  $F_y$  (service load level).

## Example Details

NotchTrak® Used For Wall Bridging<sup>1,2</sup>

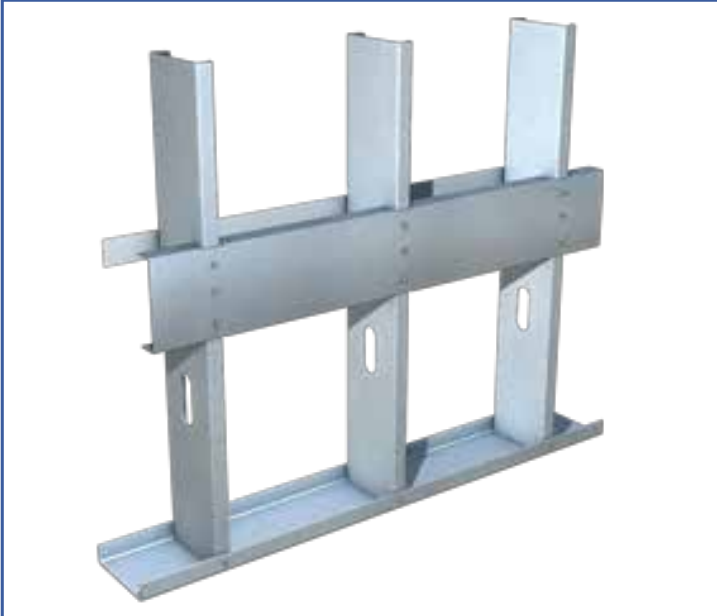

NotchTrak® Used For Wall Backing



<sup>1</sup> Use NotchTrak in conjunction with flat strap and blocking where applicable

<sup>2</sup> Design screw connection of track to stud for actual design load

**\*\*NotchTrak® allowable load tables continued on next page.**

**Nomenclature**

NotchTrak is manufactured in 12 ft. lengths. NotchTrak is designated by track depth in inches multiplied by 100, followed by type (NT), leg size, mil thickness and notch spacing.

**Example:**

600 NT 125 - 43 - 16oc  
(Inside Track Dimension) (NotchTrak) (Leg) (Thickness) (Notch Spacing)

\* Special lengths available by request.

**NotchTrak NT Allowable Loads**

NotchTrak® NT, Recommended Allowable Load (lbs): Hanger Load Direction													
Screw Patterns with #12 Screws	16" O.C. Stud Spacing						24" O.C. Stud Spacing						
	NT43		NT54		NT68		NT43		NT54		NT68		
	6" w/ 7 Screws	8" w/ 10 Screws	6" w/ 7 Screws	8" w/ 10 Screws	6" w/ 7 Screws	8" w/ 10 Screws	6" w/ 7 Screws	8" w/ 10 Screws	6" w/ 7 Screws	8" w/ 10 Screws	6" w/ 7 Screws	8" w/ 10 Screws	
33mil (20ga), 33ksi Stud	1,319	1,030	1,319	1,884	1,319	1,884	1,319	1,030	1,319	1,884	1,319	1,884	
33mil (20ga), 50ksi Stud	1,377	1,030	1,905	2,039	1,905	2,722	1,377	1,030	1,905	2,039	1,905	2,722	
43mil (18ga), 33ksi Stud	1,377	1,030	1,963	2,039	1,963	2,804	1,377	1,030	1,963	2,039	1,963	2,804	
43mil (18ga), 50ksi Stud	1,377	1,030	2,728	2,039	2,836	4,051	1,377	1,030	2,728	2,039	2,836	4,051	
54mil (16ga), 33ksi Stud	1,377	1,030	2,728	2,039	2,760	3,943	1,377	1,030	2,728	2,039	2,760	3,943	
54mil (16ga), 50ksi Stud	1,377	1,030	2,728	2,039	3,986	4,087	1,377	1,030	2,728	2,039	3,986	4,087	
68mil (14ga), 50ksi Stud	1,377	1,030	2,728	2,039	5,019	4,087	1,377	1,030	2,728	2,039	4,135	4,087	
97mil (12ga), 50ksi Stud	1,377	1,030	2,728	2,039	5,019	4,087	1,377	1,030	2,728	2,039	4,135	4,087	
<b>Max Allowable Member Load</b>	<b>1,377</b>	<b>1,030</b>	<b>2,728</b>	<b>2,039</b>	<b>5,019</b>	<b>4,087</b>	<b>1,377</b>	<b>1,030</b>	<b>2,728</b>	<b>2,039</b>	<b>4,135</b>	<b>4,087</b>	

NotchTrak® NT, Recommended Allowable Load (lbs): Axial Load Direction						
Screw Patterns with #12 Screws	16" & 24" O.C. Stud Spacing					
	NT43		NT54		NT68	
	6" w/ 7 Screws	8" w/ 10 Screws	6" w/ 7 Screws	8" w/ 10 Screws	6" w/ 7 Screws	8" w/ 10 Screws
33mil (20ga), 33ksi Stud	1,319	1,884	1,319	1,884	1,319	1,884
33mil (20ga), 50ksi Stud	1,529	2,064	1,905	2,722	1,905	2,722
43mil (18ga), 33ksi Stud	1,529	2,064	1,963	2,804	1,963	2,804
43mil (18ga), 50ksi Stud	1,529	2,064	2,836	4,051	2,836	4,051
54mil (16ga), 33ksi Stud	1,529	2,064	2,760	3,943	2,760	3,943
54mil (16ga), 50ksi Stud	1,529	2,064	3,022	4,080	3,986	5,695
68mil (14ga), 50ksi Stud	1,529	2,064	3,022	4,080	5,019	7,170
97mil (12ga), 50ksi Stud	1,529	2,064	3,022	4,080	5,019	7,170
<b>Maximum Allowable Member Load</b>	<b>1,529</b>	<b>2,064</b>	<b>3,022</b>	<b>4,080</b>	<b>5,019</b>	<b>7,170</b>

NotchTrak® NT, Recommended Allowable Out of Plane Load (lbs): Lateral Load Direction						
Screw Patterns with #12 Screws	16" O.C. Stud Spacing			24" O.C. Stud Spacing		
	NT43	NT54	NT68	NT43	NT54	NT68
33mil (20ga), 33ksi Stud	73	155	324	48	104	219
33mil (20ga), 50ksi Stud	73	155	324	48	104	219
43mil (18ga), 33ksi Stud	73	155	324	48	104	219
43mil (18ga), 50ksi Stud	73	155	324	48	104	219
54mil (16ga), 33ksi Stud	73	155	324	48	104	219
54mil (16ga), 50ksi Stud	73	155	324	48	104	219
68mil (14ga), 50ksi Stud	73	155	324	48	104	219
97mil (12ga), 50ksi Stud	73	155	324	48	104	219
<b>Max Allowable Member Load</b>	<b>73</b>	<b>155</b>	<b>324</b>	<b>48</b>	<b>104</b>	<b>219</b>

**Notes:**

1. NotchTrak NT resists weak axis buckling and torsional rotation of members.
2. Table data is based on 1-1/4" track leg, but other leg sizes are available to obtain higher capacities.
3. Meets OSHA and IBC load requirements.
4. Meets OSHPD 2013 CBC Standard Backing Details for Cabinets and Grab Bars (Details ST5.00 and ST5.03).
5. For LRFD strengths contact TSN technical services.

Load Direction

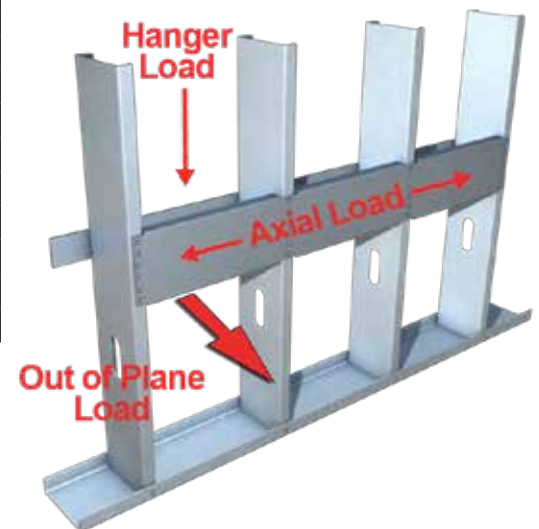

# BackIt®

Rigid Wall Backing



### Material Composition

ASTM A1003/A1003M Structural Grade 50 (340) Type H, ST50H (ST340H): 50ksi (340MPa) minimum yield strength, 65ksi (450MPa) minimum tensile strength, 43mil minimum thickness (18 gauge, 0.0451" design thickness) with ASTM A653/A653M G60 (Z180) hot dipped galvanized coating.

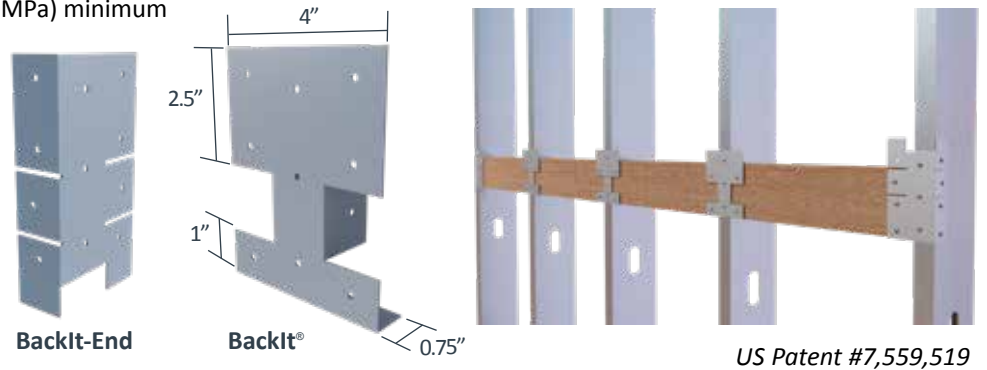

US Patent #7,559,519

### BackIt Allowable Loads

BackIt®, Recommended Allowable Load (lbs) (in-lbs or in-lbs/rad): F2 & F3 & M1 Load Direction						
Screw Patterns with #12 Screws	F2 Load Direction (lbs)		F3 Load Direction (lbs)		M1 Load Direction	
	2 Screws	3 Screws	2 Screws	3 Screws	Moment 3 Screws	Stiffness up to 0.02 rad
18mil (25ga), 33ksi Stud	-	156*	-	225	221	16,800
27mil (22ga), 33ksi Stud	-	234	278	417	332	
30mil (20ga-Drywall), 33ksi Stud	-	258	322	483	366	
33mil (20ga-Structural), 33ksi Stud	-	285	376	564	404	
33mil (20ga), 50ksi Stud	276	391	544	816	587	
43mil (18ga), 33ksi Stud	248	372	560	840	527	
43mil (18ga), 50ksi Stud	358	391	810	1,215	761	
54mil (16ga), 33ksi Stud	312	391	822	1,233	663	
54mil (16ga), 50ksi Stud	391	391	1,140	1,388	956	
68mil (14ga), 50ksi Stud	391	391	1,140	1,388	967	
97mil (12ga), 50ksi Stud	391	391	1,140	1,388	967	
<b>Maximum Allowable Clip Load</b>	<b>391</b>		<b>1,388</b>		<b>967</b>	

### Notes:

- The recommended allowable loads and moments reported in this table are for the clip and attachment to the stud only. The attachment to the backing material must be designed by a design professional.
  - For LRFD strengths contact TSN technical services.
- \*Additional screws may be added to increase the allowable load. F2 value with (4) #12 screws is 207 lbs.

IBC (International Building Code) and OSHA (Occupational Safety and Health Administration) load requirements include the ability of wall backing to resist a minimum of 200 lbs of concentrated load, or 50 lbs per linear foot in any direction. BackIt satisfies the load requirements in vertical (F3) and horizontal (F2) directions. Extra testing has been done in the rotational (M1) direction. Product test reports are available upon request. Contact TSN Technical Support at (888) 474-4876 for more information.

### Screw Patterns

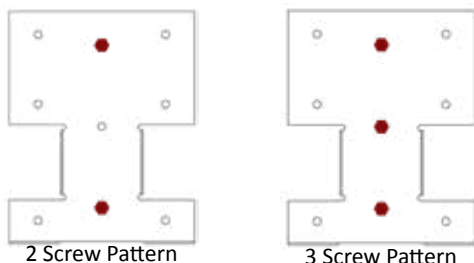

### Nomenclature

BackIt is designed to be used with studs having flanges up to 1 5/8" wide\*, and is designated BackIt®.  
 \* Custom clips are available by request for use with studs having flanges greater than 1 5/8"  
 \*\*Also Available by Request: End-of-Run BackIt® to finish walls with a flat angle

### Load Direction

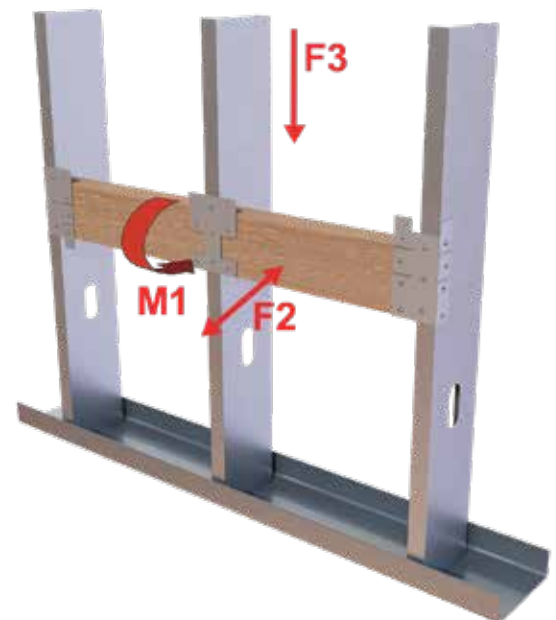

# GripClip®

Column/Beam Connector

### Material Composition

ASTM A1003/A1003M Structural Grade 50, Type H, ST50H (ST340H): 50ksi (340MPa) minimum yield strength, 65ksi (450MPa) minimum tensile strength, 33mil minimum thickness (20 gauge, 0.0346" design thickness) with ASTM A653/A653M G90 (Z275) hot dipped galvanized coating.

### Column Fire Resistance Design Numbers:

(1) Hour Rating is GC001.

(1-1/2) Hour Rating is GC001.5.

See Design Number downloads on TSN GripClip product page.

Contact TSN Sales and Engineering for performance evaluation reports.

### Nomenclature

GripClip-087 (standard) has a 'grip' range (flange sizes) of 1/4" up to 7/8".

GripClip-137 has a 'grip' range (flange sizes) greater than 7/8" up to 1-3/8".

Contact TSN Sales and Engineering for increased 'grip' ranges.

### Installation Instructions

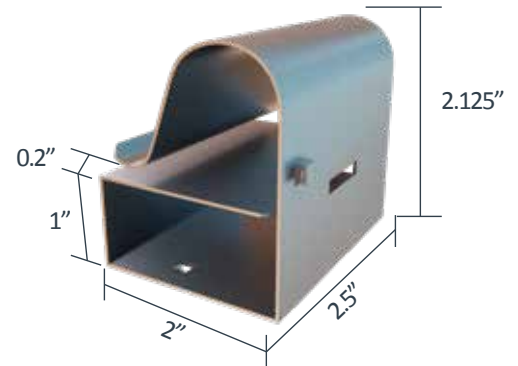

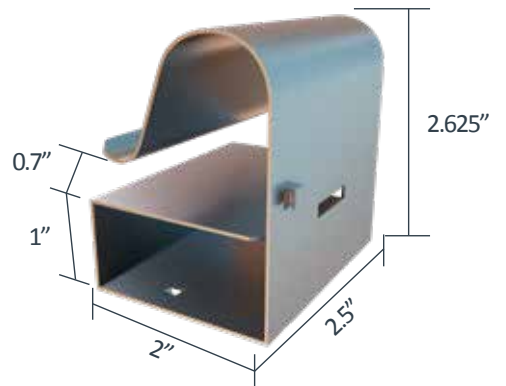

GripClip-087



GripClip-137

**Drywall GripClip® Installation Instructions**  
For the Attachment of Gypsum Wallboard to Steel Columns



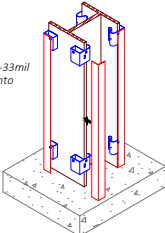
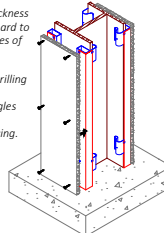
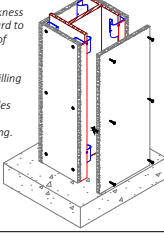
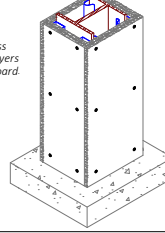
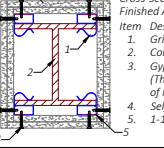

 <p>Slide GripClip® onto the flanges of the column at the specified spacing.</p> <p>Face the box shaped portion of GripClip® to the outside of the flanges.</p>	 <p>Snap 1-1/2"x1-1/2"-33mil continuous angles into GripClip® tabs.</p>	 <p>Trim specified thickness of gypsum wallboard to size for flange sides of column section.</p> <p>Attach with self drilling screws through 1-1/2"x1-1/2" angles and GripClip® at the specified spacing.</p>
 <p>Trim specified thickness of gypsum wallboard to size for web sides of column section.</p> <p>Attach with self drilling screws through 1-1/2"x1-1/2" angles and GripClip® at the specified spacing.</p>	 <p>Finish with the specified thickness and number of layers of gypsum wallboard.</p>	 <p>Cross-Section of Finished Assembly:</p> <ol style="list-style-type: none"> <li>1. GripClip®</li> <li>2. Column section</li> <li>3. Gypsum wallboard (Thickness and number of layers as specified)</li> <li>4. Self-drilling screws</li> <li>5. 1-1/2"x1-1/2"-33mil Angle</li> </ol> <p>For Installation, Technical, or Submittal questions, contact TSN at (888) 474-4876 or email us at support@steelnetwork.com</p> <p>Visit www.steelnetwork.com and discover the value of each TSN solution.</p>

© 2025 The Steel Network, Inc. All Rights Reserved US Patent #8,132,383 Rev 3 - 2-10-25

Products in these instructions are designed and manufactured for the specific purposes shown, and should not be used in other applications unless approved by a qualified design professional. All modifications to products or changes in installation procedures should be made by a qualified design professional. The performance of such modified products or altered installation procedures is the sole responsibility of the design professional or installation contractor. The installation contractor is responsible for installing all products in accordance with relevant specifications and building codes.

**Drywall GripClip® Installation Instructions**  
For the Attachment of Gypsum Wallboard to Steel Columns

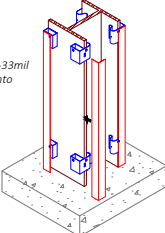
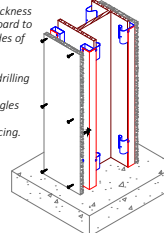
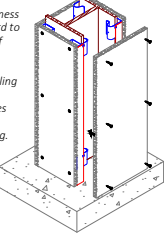
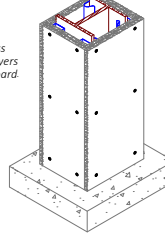
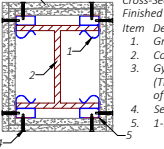

 <p>Slide GripClip® onto the flanges of the column at the specified spacing.</p> <p>Face the box shaped portion of GripClip® to the outside of the flanges.</p>	 <p>Snap 1-1/2"x1-1/2"-33mil continuous angles into GripClip® tabs.</p>	 <p>Trim specified thickness of gypsum wallboard to size for flange sides of column section.</p> <p>Attach with self drilling screws through 1-1/2"x1-1/2" angles and GripClip® at the specified spacing.</p>
 <p>Trim specified thickness of gypsum wallboard to size for web sides of column section.</p> <p>Attach with self drilling screws through 1-1/2"x1-1/2" angles and GripClip® at the specified spacing.</p>	 <p>Finish with the specified thickness and number of layers of gypsum wallboard.</p>	 <p>Cross-Section of Finished Assembly:</p> <ol style="list-style-type: none"> <li>1. GripClip®</li> <li>2. Column section</li> <li>3. Gypsum wallboard (Thickness and number of layers as specified)</li> <li>4. Self-drilling screws</li> <li>5. 1-1/2"x1-1/2"-33mil Angle</li> </ol> <p>For Installation, Technical, or Submittal questions, contact TSN at (888) 474-4876 or email us at support@steelnetwork.com</p> <p>Visit www.steelnetwork.com and discover the value of each TSN solution.</p>

© 2025 The Steel Network, Inc. All Rights Reserved US Patent #8,132,383 Rev 3 - 2-10-25

Products in these instructions are designed and manufactured for the specific purposes shown, and should not be used in other applications unless approved by a qualified design professional. All modifications to products or changes in installation procedures should be made by a qualified design professional. The performance of such modified products or altered installation procedures is the sole responsibility of the design professional or installation contractor. The installation contractor is responsible for installing all products in accordance with relevant specifications and building codes.



Patent # 8,132,383

# Common Clip Angle

Common Angle For All Applications

## Material Composition

ASTM A1003/A1003M Structural Grade 50 (345) 50ksi (345MPa) minimum yield strength, 65ksi (450MPa) minimum tensile strength, with ASTM A653/A653M G90 (Z275) hot dipped galvanized coating. Available in 33mil minimum thickness (20 gauge, 0.0346" design thickness), 43mil minimum thickness (18 gauge, 0.0451" design thickness), 54mil minimum thickness (16 gauge, 0.0566" design thickness), 68mil minimum thickness (14 gauge, 0.0713" design thickness), 97mil minimum thickness (12 gauge, 0.1017" design thickness) or 118 mil minimum thickness (10 gauge, 0.1242" design thickness).

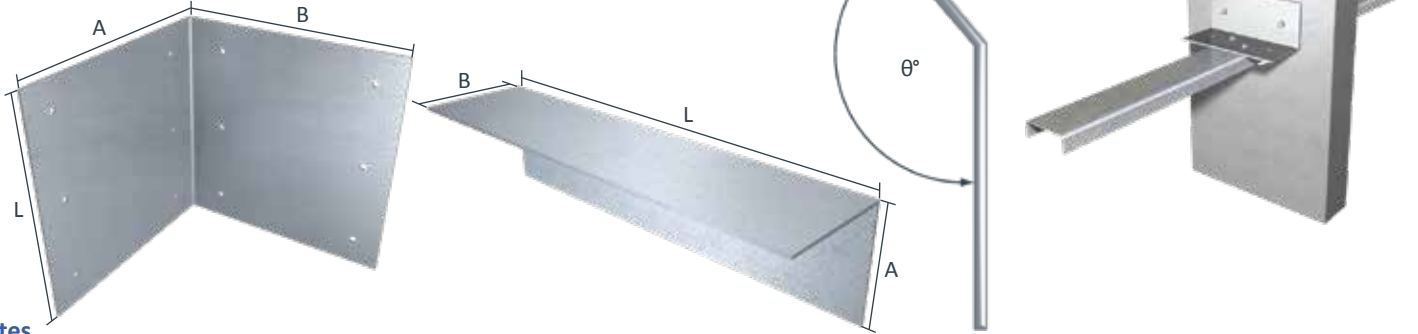

## Notes

- The Steel Network is equipped to manufacture cold-formed steel connections of any size and shape. Some examples of common clip angle manufactured and stocked are shown below.
- Most common stocked angles come pre-punched for easier installation, although holes are not required.
- Contact TSN Sales for range of custom clip bend angles and for assistance designing custom products for special applications or requirements. Please allow reasonable time for production of all custom parts.
- Any thickness up to & including 10ga (118mil)
- Structural testing is available upon request.

## Nomenclature

Clip angle can be manufactured to any specifications, however TSN stocks some more common sizes. Angle is classified with the letter "L" followed by (Leg A) x (Leg B) x length (inches), then mil thickness.

**Example:** Leg A = 3", Leg B = 3", Length = 5 1/2", 54 mil material

**Designate:** L3x3x5.5-54

\* Special product drawings are required for all non-standard products.

## Example Standard Common Clip Angle Details

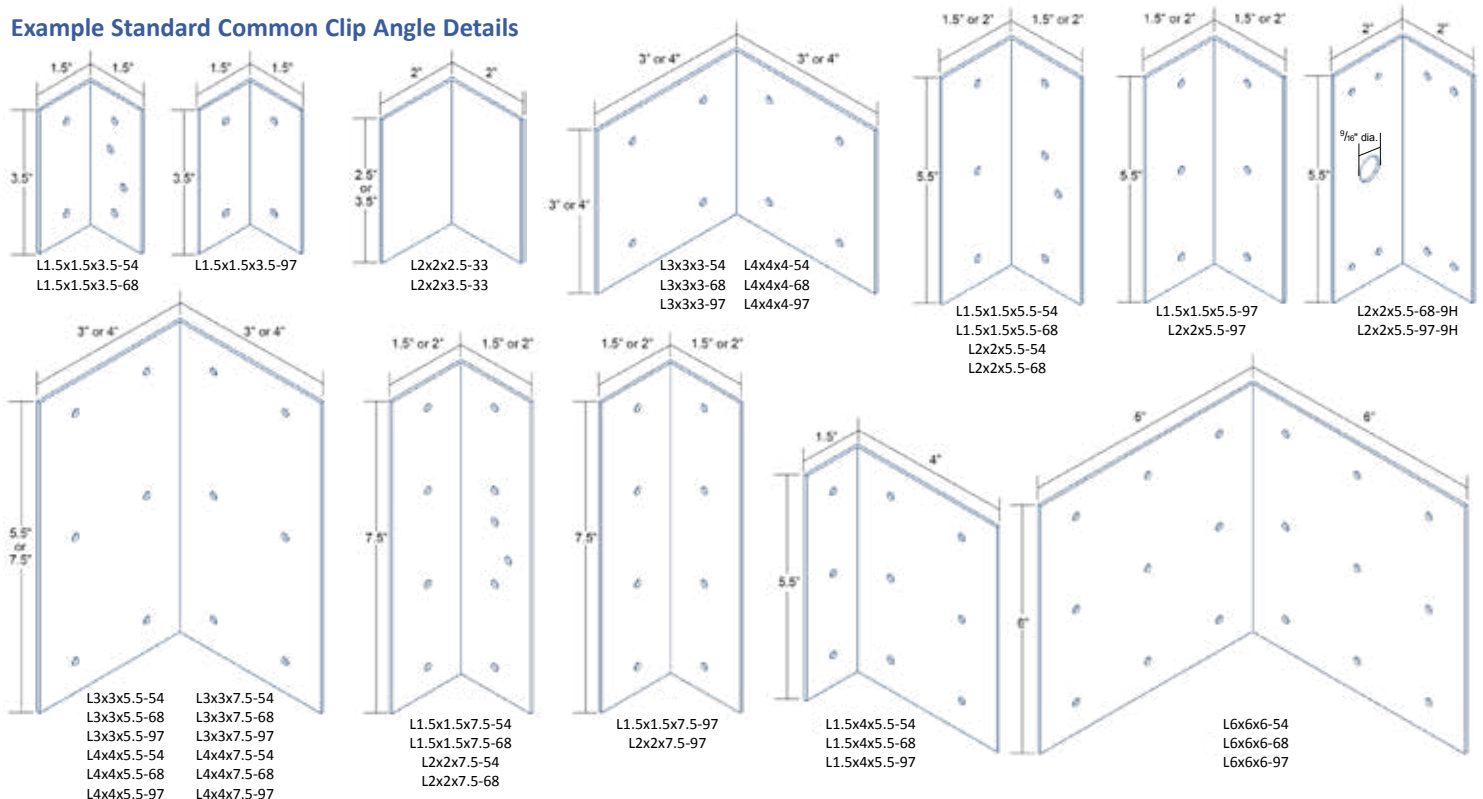

# Custom Connectors

Specialized Products For All Applications

## Material Composition

ASTM A1003/A1003M Structural Grade 50 (345) 50ksi (345MPa) minimum yield strength, 65ksi (450MPa) minimum tensile strength, with ASTM A653/A653M G90 (Z275) hot dipped galvanized coating. Available in 33mil minimum thickness (20 gauge, 0.0346" design thickness), 43mil minimum thickness (18 gauge, 0.0451" design thickness), 54mil minimum thickness (16 gauge, 0.0566" design thickness), 68mil minimum thickness (14 gauge, 0.0713" design thickness), 97mil minimum thickness (12 gauge, 0.1017" design thickness) or 118 mil minimum thickness (10 gauge, 0.1242" design thickness).

## Notes

- The Steel Network is equipped to manufacture cold-formed steel connections of any size and shape. Some examples of custom products manufactured are shown and described below.
- Please allow reasonable time for production of all custom parts.
- Structural testing is available upon request.
- Contact TSN for assistance designing custom products for special applications or requirements.



## Nomenclature

Contact TSN with product requirements

*\* Special product drawing is required for all non-standard products.*

## Example Details

Custom VertiClip® SLB

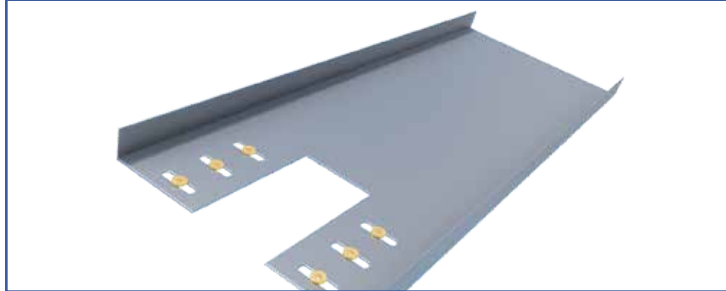

Unique condition brought to TSN by Specialty Engineer. TSN helped design a solution and test & fabricate clips.

Custom VertiClip® Splice (Notched)



Unique condition brought to TSN by Specialty Engineer. TSN helped design a solution and test & fabricate clips.

Custom VertiClip® Splice (Angled)



Unique condition brought to TSN by Specialty Engineer. TSN helped design a solution and test & fabricate clips.

Custom VertiClip® Splice



Connector for parallel wall studs. One stud rigidly attached to wall stud. The other stud accommodates vertical deflection of the primary structural frame.

Custom VertiClip® SLS (extra long)



Retrofit situation where a stud does not run full height, creating a situation where a modified VertiClip SLS was lengthened to bridge a large gap from the structure of 26".

Custom VertiTrak® VTD (VertiClip® SLD with Elongated Slots)



VertiTrack VTD modified to accommodate 4" slots in VertiClip SLD provides an effective, efficient solution for large demising walls typically seen in retail stores and theaters.

# Blast & Seismic Design

## Load Tables

VertiClip® Series (lbs)				
Connector	Load Direction	LRFD Design Strength (lbs)	Nominal Strength (lbs)	Ultimate Strength (lbs)
SL362	F1	397	441	721
	F2	1,700	1,889	2,680
SL400	F1	318	353	600
	F2	1,817	2,019	3,074
SL600	F1	588	653	1,068
	F2	2,690	2,989	4,251
SL800	F1	579	643	1,052
	F2	2,990	3,322	4,730
SL1000	F1	664	738	1,206
	F2	2,521	2,801	4,266
SL1200	F1	611	679	1,110
	F2	2,863	3,182	4,845
SLD150	F2	82	91	139
SLD250	F2	254	282	430
SLD362/400	F2	575	639	973
SLD600	F2	650	722	1,302
SLD800	F2	1,091	1,212	1,844
SLB250	F1	362	402	612
	F2	2,509	2,788	4,245
SLB362	F1	362	402	612
	F2	2,560	2,788	4,245
SLB600	F1	362	402	612
	F2	2,560	2,844	4,245
SLB600-HD (2) ¼" Anchor	F1	374	416	679
	F2	1,901	2,112	3,216
SLB600-HD (1) ½" Anchor	F1	375	417	673
	F2	1,606	1,785	2,718
SLB800	F1	440	489	745
	F2	2,509	2,788	4,254
SLB1000	F2	2,430	2,700	4,112
SLB1200	F2	2,430	2,700	4,112
SLBxxx-10, -12	F2	2,430	2,700	4,112
SLS362/400-9, -12	F2	1,991	2,212	3,821
SLS600-12	F2	3,315	3,683	5,237
SLS600-15, -18, -20	F2	3,398	3,577	5,750
SL600-24	F2	3,036	3,373	5,137
SLS800-12, -15, -18, -20	F2	2,909	3,232	4,922
SLT9.5	F1	546	607	991
	F2	820	911	1,492
SLT(L)-12	F1	784	871	1,422
	F2	1,446	1,606	2,446
SLT(L)-15	F1	784	871	1,422
	F2	1,191	1,324	2,016
SLT(L)-18	F1	784	871	1,422
	F2	1,120	1,244	2,026
SLT(S)	F1 (Back Fasteners)	451	501	814
	F2 (Back Fasteners)	1,469	1,632	2,485
	F1 (Back Fasteners)	631	701	1,068
	F2 (Back Fasteners)	1,425	1,584	2,412
Splice600	F2	2,126	2,363	3,598
	F3	3,888	4,320	6,578
Splice800	F2	2,126	2,363	3,598
	F3	3,639	4,044	6,158

**Notes:**

LStrength values provided are those of the clip only (One clip). Attachment to stud framing and to structure must be evaluated independently.  
Nominal Strength is calculated as LRFD Strength divided by an average resistance factor of 0.9.  
Ultimate Strength is the average maximum load obtained from tests.  
When dynamic analysis is used for blast design, the Nominal Strength may be allowed to be increased by a Static Increase Factor (SIF) and a Dynamic Increase Factor (DIF).

**Background**

Various specifications and design standards allow the use of nominal strength of material when calculating resistance values of components for special blast or seismic design. Beyond the use of nominal strength, some design codes allow the use of an increased nominal strength or an increased expected strength. The Steel Network has developed the following tables to present the LRFD design strength, nominal strength, and ultimate strength for each connector manufactured which can be used in special seismic and blast design and are compatible with the Static and Dynamic Strength Increase factors.

For additional information the full tech note, Strength Tables for Special Seismic and Blast Design of Cold Formed Steel Connections is available at [www.steelnetwork.com/Site/TechnicalNotes](http://www.steelnetwork.com/Site/TechnicalNotes)

MasterClip® Series (lbs)				
Connector (Application)	Load Direction	LRFD Design Strength	Nominal Strength	Ultimate Strength
VLB600 (Vertical Deflection)	F1	362	402	661
	F2	2,509	2,788	4,245
VLB600 (Rigid Connection)	F1	1,481	1,646	2,506
	F2	3,297	3,664	5,579
	F3	2,869	3,188	4,855
VLB800 (Vertical Deflection)	F1	440	489	745
	F2	2,509	2,788	4,245
VLB800 (Rigid Connection)	F1	1,576	1,751	2,667
	F2	3,586	3,984	6,067
	F3	2,032	2,258	3,438

DriftClip® Series (lbs)					
Connector	Load Direction	Fastener Pattern	LRFD Design Strength (lbs)	Nominal Strength (lbs)	Ultimate Strength (lbs)
DSL362, 600, 800	F2	1	1,467	1,630	2,317
		2	916	1,018	1,663
DSL362/400-9	F2	1	1,536	1,707	2,787
		2	1,507	1,674	2,735
DSL362/400-12	F2	1	1,977	2,197	3,588
		2	1,722	1,913	3,126
DLS600-10	F2	1	1,924	2,138	3,864
		2	1,627	1,808	2,952
DLS600-12	F2	1	2,980	3,311	4,707
		2	2,787	3,097	4,405
DLS600-15 <sup>1</sup>	F2	1	3,044	3,382	4,811
		2	3,044	3,382	4,811
DLS600-20 <sup>1</sup>	F2	1	3,582	3,980	4,811
		2	2,664	2,960	4,507
DLS800-12	F2	1	1,859	2,066	3,374
		2	1,850	2,056	3,358
DLS800-15	F2	1	3,026	3,362	5,492
		2	1,915	2,128	3,475
DLS800-20	F2	1	2,917	3,241	5,492
		2	1,991	2,212	4,123
DSL362	F2	1	186	207	317
		2	85	94	141
DSL600 <sup>1</sup>	F2	1	285	317	481
		2	285	317	481
DSL800	F2	1	318	354	578
		2	294	327	858
DSL362	F2	1	796	884	1,320
		2	397	441	720
DSL600 <sup>1</sup>	F2	1	1,241	1,379	2,254
		2	1,665	1,850	3,023
DSL800 <sup>1</sup>	F2	1	1,665	1,850	3,023
		2	1,467	1,630	2,317

Visit [www.steelnetwork.com/Site/TechnicalNotes](http://www.steelnetwork.com/Site/TechnicalNotes) to view the full technical note on Blast and Seismic Design.

DriftClip® Series (lbs)					
Connector	Load Direction	Fastener Pattern	LRFD Strength (lbs)	Nominal Strength (lbs)	Ultimat Strength (lbs)
DT w/ DTSL	F2	8" Fastener Spacing - Pattern 1	1,001	1,112	1,807
		8" Fastener Spacing - Pattern 2	771	857	1,303
		16" Fastener Spacing - Pattern 2	1,001	1,112	1,807
		16" Fastener Spacing - Pattern 2	774	860	1,309
DT w/ DTSLB362/400, DTSLB600, DTSLB800	F2	8" Fastener Spacing - Pattern 2	1,293	1,437	2,186
		16" Fastener Spacing - Pattern 2	1,206	1,340	2,040
DT w/ DTSLB362/400-HD, DTSLB600-HD, DTSLB800-HD,	F2	8" Fastener Spacing - Pattern 1 & 2	2,591	2,879	4,384
		16" Fastener Spacing - Pattern 1 & 2	1,640	1,822	2,775
DT w/ DTLB362/400	F2	8" Fastener Spacing	1,613	1,792	2,729
	F3		1,859	2,065	3,145
DT w/ DTLB600	F2	8" Fastener Spacing	1,914	2,126	2,935
	F3		2,803	3,115	4,743
DT w/ DTLB800	F2	8" Fastener Spacing	1,914	2,126	2,935
	F3		2,037	2,264	3,447
DT w/ DTLB362/400-HD	F2	8" Fastener Spacing	2,104	2,338	3,560
	F3		1,859	2,065	3,145
DT w/ DTLB600-HD	F2	8" Fastener Spacing	2,796	3,106	4,288
	F3		2,803	3,115	4,743
DT w/ DTLB800-HD	F2	8" Fastener Spacing	2,796	3,106	4,288
	F3		2,037	2,264	3,447
DTH w/ DTSLB362/400-HD, DTSLB600-HD, DTSLB800-HD,	F2	Headed Stud	2,649	2,943	4,063
DTH w/ DTLB362/400-HD	F2	Headed Stud	2,649	2,943	4,063
	F3		1,859	2,065	3,145
DTH w/ DTLB600-HD	F2	Headed Stud	2,649	2,943	4,063
	F3		3,047	3,386	4,674
DTH w/ DTLB800-HD	F2	Headed Stud	2,649	2,943	4,063
	F3		2,037	2,264	3,447
PTS w/ DTSLB600-PTS, DTSLB800-PTS	F2 Bottom of Slab Installation	Headed Stud – PTS	1,726	1,918	2,701
	F2 Top of Slab Installation		1,856	2,062	3,912
PTS w/ DTLB600-PTS	F2 Bottom of Slab Installation	Headed Stud – PTS	1,815	2,017	2,784
	F2 Top of Slab Installation		2,165	2,406	3,321
	F3		1,856	2,062	2,846
PTS w/ DTLB800-PTS	F2 Bottom of Slab Installation	Headed Stud – PTS	1,775	1,973	2,723
	F2 Top of Slab Installation		2,120	2,355	3,251
	F3		1,599	1,777	2,453

**Notes:**

- 1 Strength values limited by corresponding 8" fastener spacing.
2. Strength values provided are those of the clip only (One clip). Attachment to stud framing and to structure must be evaluated independently.
3. Nominal Strength is calculated as the LRFD Strength divided by an average resistance factor of 0.9.
4. Ultimate Strength is maximum load obtained from tests.
5. When dynamic analysis is used for blast design, the Nominal Strength may be allowed to be increased by a Static Increase Factor (SIF) and a Dynamic Increase Factor (DIF).

StiffClip® Series (lbs or in-lbs)					StiffClip® Series (lbs or in-lbs)				
Connector	Load Direction	LRFD Design Strength	Nominal Strength	Ultimate Strength	Connector	Load Direction	LRFD Design Strength	Nominal Strength	Ultimate Strength
AL362	F1	1,562	1,736	2,643	CL362/400-118	F1	2,267	2,519	4,122
	F2	2,354	2,616	3,983		F2	3,071	3,412	4,851
	F3	3,937	4,374	6,661		F3	1,842	2,047	3,349
AL600	F1	1,388	1,542	2,348		M1 (in-lbs)	2,888	3,209	5,251
	F2	3,493	3,882	5,911	CL362/400-118	F1	3,880	4,311	6,129
	F3	4,830	5,366	8,172		F2	7,090	7,878	11,201
AL800	F1	2,827	3,141	4,784		F3	3,611	4,012	6,565
	F2	4,022	4,469	6,806		M1 (in-lbs)	6,299	6,999	11,453
	F3	9,798	10,887	16,579	CL362/400-118H	F1	4,160	4,622	6,572
LB362	F1	1,641	1,823	2,776		F2	7,973	8,858	12,595
	F2	3,297	3,664	5,579		F3	9,150	10,167	14,455
	F3	4,256	4,729	7,202		M1 (in-lbs)	10,750	11,944	19,545
LB600	F1	1,481	1,646	2,506	CL600-68	F1	2,275	2,528	3,594
	F2	3,297	3,664	5,579		F2	4,020	4,467	6,351
	F3	3,080	3,423	5,212		F3	1,932	2,147	3,513
LB800	F1	1,576	1,751	2,667		M1 (in-lbs)	4,978	5,531	9,050
	F2	3,297	3,664	5,579	CL600-118	F1	4,131	4,590	7,147
	F3 (4 #12 Screws Max.)	2,032	2,258	3,438		F2	6,578	7,308	10,391
F3 (10 #12 Screws Max.)	6,188	6,875	10,470	F3		3,561	3,956	6,474	
LB800-4" Offset	F1	1,993	2,214	3,617		M1 (in-lbs)	9,126	10,140	16,592
	F2	3,297	3,664	5,579	CL600-118H	F1	6,659	7,399	10,520
	F3	2,496	2,773	4,223		F2	10,337	11,485	16,330
LB1000	F1	1,465	1,627	2,658		F3	9,620	10,689	15,197
	F2	2,270	2,522	4,120		M1 (in-lbs)	9,958	11,065	18,106
	F3	2,872	3,191	4,859	CL800-68	F1	2,298	2,553	3,630
LB1000 - 4" Offset	F1	1,465	1,627	2,658		F2	4,263	4,736	6,734
	F2	2,270	2,522	4,120		F3	1,724	1,916	3,135
	F3	2,506	2,784	4,240		M1 (in-lbs)	4,578	5,086	8,323
LB1200	F1	1,465	1,627	2,658	CL800-118	F1	5,375	5,972	8,491
	F2	2,270	2,522	4,120		F2	1z	11,406	16,217
	F3	3,041	3,379	5,146		F3	4,270	4,744	8,291
LB600-HD, (2) ¼" Screws	F1	1,764	1,959	2,984		M1 (in-lbs)	13,170	14,634	23,946
	F2	1,810	2,011	3,062	CL800-118H	F1	7,713	8,570	12,185
	F3	3,149	3,499	5,328		F2	13,251	14,723	20,933
HE(L)	F2	1,003	1,114	1,696		F3	11,925	13,250	18,839
	F3	4,901	5,446	8,293		M1 (in-lbs)	17,834	19,815	32,425
	HE(H)	F2	1,739	1,932	2,943	TD	F3	15,722	17,469
F3		8,880	9,867	15,026					
HE(S)		F2	1,739	1,932	2,943				
	F3	4,753	5,281	8,043					
HS362*	F2*	4,420	8,840	11,492					
	F3	1,773	1,970	3,000					
HS600*	F2*	6,630	13,260	17,238					
	F3	2,943	3,270	4,980					
HS800*	F2*	6,630	13,260	17,238					
	F3	3,885	4,317	6,574					

**Notes:**

- \* Clip connectors and load directions have their LRFD, nominal, and ultimate strength values all calculated using AISI S100-16 provisions.
- 1. Strength values provided are those of the clip only (One clip). Attachment to stud framing and to structure must be evaluated independently.
- 2. Nominal Strength is calculated as LRFD Strength divided by an average resistance factor of 0.9.
- 3. Ultimate Strength is the average maximum load obtained from tests.
- 4. When dynamic analysis is used for blast design, the Nominal Strength may be allowed to be increased by a Static Increase Factor (SIF) and a Dynamic Increase Factor (DIF).

MidWall® Series (lbs)				
Connector	Load Direction	LRFD Design Strength	Nominal Strength	Ultimate Strength
250MW	M1 (in-lbs)	9,855	10,950	12,288
362MW	M1 (in-lbs)	25,567	28,408	31,104
600MW	M1 (in-lbs)	31,328	34,809	38,112

**Notes:**

1. Strength values provided are those of the clip only (One clip). Attachment to stud framing and to structure must be evaluated independently.
2. Nominal Strength is calculated as LRFD Strength divided by an average resistance factor of 0.9.
3. Ultimate Strength is the average maximum load obtained from tests.
4. When dynamic analysis is used for blast design, the Nominal Strength may be allowed to be increased by a Static Increase Factor (SIF) and a Dynamic Increase Factor (DIF).

# Building Codes & Fire Ratings

## Building Code Reference

### ICC-ES

The Steel Network assisted the ICC-ES in the development of AC261, "Acceptance Criteria for Connectors Used with Cold-Formed Steel Structural Members," which establishes test protocols and requirements for connections used in cold-formed steel assemblies. TSN provides structural test reports for each connector product which are in compliance with the listed criteria.

#### 2021 IBC (Section 715.2):

**Installation:** A fire-resistant joint system shall be securely installed in accordance with the manufacturer's installation instructions and the listing criteria in or on the joint for its entire length so as not to impair its ability to accommodate expected building movements and to resist the passage of fire and hot gases.

#### 2021 IBC (Section 715.3.1):

**Fire test criteria:** Fire-resistant joint systems shall be tested in accordance with the requirements of either ASTM E1966 or UL 2079.



ICC-ES Evaluation Reports for select VertiClip®, DriftClip® & DriftTrak® products are available. Refer to ICC-ES ESR-2049 at [www.icc-es.org](http://www.icc-es.org) or at [www.steelnetwork.com](http://www.steelnetwork.com)



A New York MEA Acceptance for VertiClip SLD & VertiTrack® VTD is available. Refer to MEA-326-06-M.

### Fire Rating Criteria

Full-height interior partitions are often required to be fire-rated. Fire-resistive joint systems require movement capabilities at head of wall. UL 2079 is a test standard for fire-resistive joint systems and includes requirements for the system's ability to allow building movement. Since the runner track or deflection channel in UL HW-D (Head of Wall-Dynamic) fire-resistive joint system assemblies provide closure to the assembly and must be fire tested for each assembly, the clip components of the assembly must only satisfy the criteria for cyclic movement. The Steel Network's VertiClip® SLD and DriftClip® DSLD series clips both satisfy the criteria for cyclic movement and are classified for use in all UL 2079 rated assemblies with a 1 or 2 hour ratings and up to 1-1/2" of deflection for SLD and 2" of deflection for DSLD. The Steel Network's VertiTrack® VTD, VTX and VT are also classified for use in certain UL HW-D fire-resistive joint system assemblies as listed below.

### UL®-Classified Assemblies

VertiClip® SLD150, SLD250, SLD362, SLD400, SLD600 and SLD800 installed with standard ceiling runners or generic deflection channels are classified for use in all UL 2079 rated Head of Wall-Dynamic joint systems rated for 1 or 2 hours with maximum movement capabilities of 3/4" compression and 3/4" extension.

DriftClip® DSLD362/400, DSLD600 and DSLD800 installed with standard ceiling runners or generic deflection channels are classified for use in all UL 2079 rated Head of Wall-Dynamic joint systems rated for 1 or 2 hours with maximum movement capabilities of 1" compression and 1" extension.

VertiTrack VTD or VTX, Series 250, 362, 400, 600 and 800 consist of VertiClip SLD and SL clips pre-attached to a standard top track. VertiTrack VTD and VTX both allow maximum movement capabilities of 3/4" compression and 3/4" extension and are classified for use in the following UL HW-D joint system details:



HW-D-0003, HW-D-0024, HW-D-0025, HW-D-0036, HW-D-0042, HW-D-0043, HW-D-0044, HW-D-0045, HW-D-0046, HW-D-0047, HW-D-0048, HW-D-0049, HW-D-0054, HW-D-0062, HW-D-0063, HW-D-0066, HW-D-0067, HW-D-0068, HW-D-0069, HW-D-0071, HW-D-0072, HW-D-0073, HW-D-0076, HW-D-0077, HW-D-0082, HW-D-0083, HW-D-0084, HW-D-0085, HW-D-0087, HW-D-0089, HW-D-0091, HW-D-0102, HW-D-0106, HW-D-0152, HW-D-0154, HW-D-0160, HW-D-0162, HW-D-0167, HW-D-0184, HW-D-0185, HW-D-0186, HW-D-0190, HW-D-0193, HW-D-0209, HW-D-0218, HW-D-0246, HW-D-0256, HW-D-0259, HW-D-0263, HW-D-0271, HW-D-0272, HW-D-0275, HW-D-0277, HW-D-0278, HW-D-0280, HW-D-0293, HW-D-0299, HW-D-0310, HW-D-0313, HW-D-0321, HW-D-0322, HW-D-0324, HW-D-0341, HW-D-0342\*, HW-D-0353, HW-D-0356, HW-D-0357, HW-D-0358, HW-D-0363, HW-D-0365, HW-D-0368, HW-D-0370,

HW-D-0371, HW-D-0401\*, HW-D-0404, HW-D-0420, HW-D-0421, HW-D-0453, HW-D-0455, HW-D-0460, HW-D-0461, HW-D-0462, HW-D-0463, HW-D-0466, HW-D-0468, HW-D-0470, HW-D-0475, HW-D-0477, HW-D-0483, HW-D-0491, HW-D-0526, HW-D-0527, HW-D-0532, HW-D-0545, HW-D-0639, HW-D-0642\*, HW-D-0644\*, HW-D-0645\*, HW-D-0646\*, HW-D-0687, HW-D-0689, HW-D-0695, HW-D-0696

The list is updated as UL classifies new assemblies. Please visit [www.portal.steelnetwork.com/light-steel-framing-fire-rated-details](http://www.portal.steelnetwork.com/light-steel-framing-fire-rated-details) and click on the UL link for a complete list of VertiTrack HW-D classified fire rated construction systems.

\* Shaft wall assemblies

# Terms, Conditions & Limited Warranty

For All Products Manufactured by The Steel Network, Inc.

## Product Use

Products in this catalog are designed and manufactured for the specific purposes shown, and should not be used in other applications unless approved by a qualified design professional. All modifications to products or changes in installation procedures should be made by a qualified design professional. The performance of such modified products or altered installation procedures is the sole responsibility of the design professional or installation contractor. The installation contractor and/or qualified design professional are responsible for installing all products in accordance with relevant specifications and building codes.

Customers modifying products or installation procedures, or designing Custom products for fabrication by The Steel Network, Inc. ("TSN") shall, regardless of specific instructions to the user, indemnify, defend, and hold TSN harmless for any and all claimed loss or damage occasioned in whole or in part by Custom or modified products or installation procedures.

Loads published on TSN's website and current product catalogs are for the described specific applications of properly installed products. Modifications to TSN products, improper loading or installation procedures, or deviations from recommended applications will affect TSN products' load-carrying capacities. TSN products are fabricated from hot-dipped galvanized steel for corrosion protection but will corrode and lose load-carrying capacity if exposed to salt air, corrosive fire-retardant chemicals, fertilizers, or other substances that may adversely affect steel or its galvanized coating. The current editions of TSN's catalogs and load tables published on this website may reflect changes in the allowable loads and configurations of some of TSN's products. This information supersedes information in earlier catalogs or technical reports. All earlier catalogs or technical reports should be discarded and reference made exclusively to the versions available at <http://www.steelnetwork.com/Site/Catalogs>. TSN may correct any clerical or typographical errors. All sales are subject to TSN's standard terms and conditions of sale.

## Limited Warranty

TSN warrants its products to be free from defects in material or workmanship at the time of shipment. TSN standard catalog products are warranted for adequacy of design when used in accordance with design limits in this catalog and properly specified and installed. TSN products shall not be substituted with non-TSN products if it is part of a system. Substitution of a TSN product will immediately void any warranty claim made by Purchaser. This warranty excludes uses not in compliance with specific applications and installation procedures set forth in this catalog. Warranty claims must be made by Purchaser in writing within ninety (90) days of receipt of the products.

All warranty obligations of TSN shall be limited, at the sole discretion of TSN, to repair or replace the defective product(s). These remedies shall constitute TSN's sole obligation and sole remedy of purchaser under this warranty. In no event will TSN be responsible for incidental, consequential, indirect, exemplary, special, consequential, or punitive damages, or other losses or damages however caused, including, but not limited to, installation costs, lost revenue or lost profits. TSN's liability for damages shall in no event exceed the applicable portion of the purchase price for defective product(s).

Product defects that arise from acts of God, accidents, misuse, misapplication, improper installation, storage damage, negligence, or modification to product(s) or its components are specifically excluded from this warranty. Product defects that arise from Purchaser providing incorrect information to TSN, including but not limited to incorrect specifications such as incorrect dimensions, designs and/or loads, are also specifically excluded from this warranty. TSN does not authorize any person or party to assume or create for it any other obligation or liability in connection with Products except as set forth herein.

This Warranty is expressly in lieu of all other warranties, expressed or implied, including any warranties of merchantability or fitness for a particular purpose, all such other warranties being hereby expressly excluded.

## Patented Technology

BackIt®, BridgeBar®, BridgeClip®, BuckleBridge®, CircleTrak®, DriftClip®, DriftCorner®, DriftTrak®, GripClip®, 600JAM®, 800JAM®, JamStud®, MidWall™, MasterClip®, NotchTrak®, PrimeWall®, 600SG®, 800SG®, SigmaStud®, SigmaTrak®, Step-Bushing Technology™, StiffClip®, StiffWall®, ThermaFast®, TightStrap®, VertiClip®, and VertiTrack® are trademarked products, and are patented or patent-pending technologies of TSN. Numerous TSN design configurations are patented and/or patent pending and are protected under US and International patent laws. Patent numbers include: #4,970,410; #4,970,411; #4,970,412; #4,970,413; #5,079,710; #5,467,566; #5,904,023; #5,906,080; #6,612,087; #6,701,689; #6,892,504; #7,104,024; #7,503,150; #7,559,519; #7,596,921; #7,634,889; #7,788,878; #7,832,162; #7,836,657; #8,132,383; #8,181,419; #8,205,402; #8,387,321 and #8,683,770.

## Contact Information

### North Carolina

(Headquarters)  
2012-A T W Alexander Drive  
P.O. Box 13887  
Durham, NC 27709  
Phone: (919) 845-1025  
Fax: (888) 474-4877

### Texas

600 Lemens Avenue  
Suite 120  
Hutto, TX 78634  
Phone: (512) 642-9603  
Fax: (512) 857-1663

### Arizona

3717 E. Broadway Road  
Suite 6  
Phoenix, AZ 85040  
Phone: (602) 830-6025  
Fax: (919) 845-1028

**Web Site:** [www.steelnetwork.com](http://www.steelnetwork.com)  
**E-mail:** [support@steelnetwork.com](mailto:support@steelnetwork.com)

**Toll Free Nationwide Phone**  
**(888) 474-4876**



