

QUALITY LIGHT STEEL FRAMING CONNECTIONS AND MEMBERS

LIGHT STEEL FRAMING MEMBERS

LOAD BEARING STUDS · X-BRACE SHEAR WALL · FLOOR JOIST SYSTEM



STEELNETWORK.COM
1.888.474.4876

About The Steel Network, Inc.:

The Steel Network, Inc. (TSN) provides solutions for all standard light steel framing applications, including load-bearing mid-rise construction systems, curtain wall systems, floor joist systems, rigid connectors, vertical deflection connectors, lateral drift connectors and anchorage connectors. Substantial effort has been made by the industry to standardize construction practices to ensure the positive connections of light steel framing components. Toward this end, all TSN products have undergone extensive field and laboratory testing to achieve complete solutions for both designers and installers. TSN's load bearing mid-rise construction system is widely used in commercial and government construction, such as hotels, dormitories and military barracks.

TSN's competitive advantage lies in the cost savings, rapid construction and green design/construction options provided by its core product lines, SigmaStud® and StiffWall® Load-bearing Shear Wall System, PrimeJoist®, JamStud®, Curtain Wall Stud BridgeClip®, VertiClip®, DriftClip®, DriftTrak® and Engineering Software.

Table of Contents

SigmaStud® Introduction.....	2
SigmaStud® Product Profile.....	3-4
SigmaStud® Section Properties.....	5-6
SigmaStud® Design Example.....	7
SigmaStud® Combined Axial & Lateral Load Tables.....	8-39
SigmaStud® STC Ratings and UL Assemblies.....	40
SigmaStud® Web Reinforcement.....	41
SigmaTrak® Introduction.....	42
SigmaTrak® Section Properties.....	43-44
Design Assist Services.....	45
Temporary Bracing.....	46
Construction Guide.....	47-48
Bridging Example Problem.....	49
Bridging Anchorage.....	50
StiffWall® Shear Wall System Introduction.....	51-52
StiffWall® SWS Design.....	53-54
Pre-Assembled Columns/Boots.....	55
StiffWall® Column Product Profile.....	56-59
StiffWall® Column Section Properties.....	60-61
StiffWall® Column Axial Load Tables.....	62-64
StiffWall® Boots.....	65-66
StiffWall® SWS Example Problem.....	67-69
Flat Strap.....	70
TightStrap® Strap Tensioner.....	71
Other Design Considerations for Shear Wall Systems.....	72
SWS Example Details.....	73
Floor Systems Introduction.....	74
PrimeJoist® Introduction.....	75
Floor System Fire & Sound Tested Assemblies.....	76
Floor System Design Considerations.....	77
PrimeJoist® Product Profile.....	78-79
PrimeJoist® Section Properties.....	80-81
Allowable Floor Joist Span Tables.....	82-9-0
Allowable Web Crippling.....	91-95
Floor Joist Framing Solutions.....	96
PrimeJoist® Example Details.....	97
SigmaPan®	98
SteelSmart® System Design Software.....	99

Copyright © 2026 The Steel Network Inc. All rights reserved. No part of this publication may be reproduced in whole or in part by any method without the prior written consent of The Steel Network, Inc.

600SG250-43, 50ksi

Overall Depth
Ex: 6"

SG
SigmaStud® Section

Flange Width (in)
x 100
Ex: 2.5"

Material Thickness (mils)
Ex: 43mil (18ga)

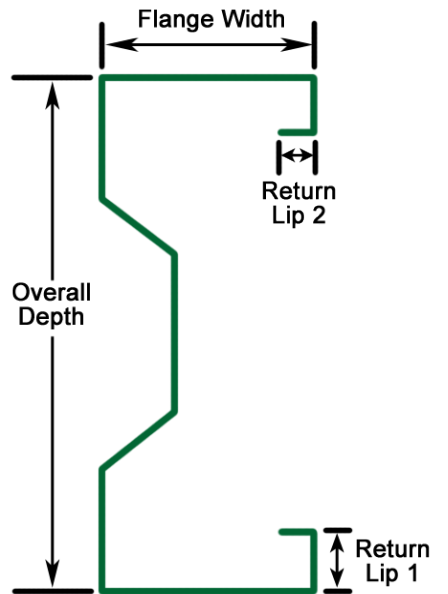

Background

SigmaStud® is a breakthrough in the load-bearing steel stud industry, producing significant increases in load capacity when compared with conventional "C" Shaped studs. SigmaStud's unique configuration provides installation and design advantages which create efficiencies no other light steel framing (LSF) load bearing wall stud can provide. Each bend made to a flat LSF element increases load capacity over a standard stud section with the same material thickness. The return lips present in SigmaStud also increase capacity, delivering the most efficient LSF load-bearing stud member available. SigmaStud redefines previous limitations considered for utilization of steel studs in building construction, producing more cost-effective options for designing load bearing walls for clients.

Material Properties:

ASTM A1003/A1003M Structural Grade 50 (340) Type H, ST50H (ST340H): 50ksi (340MPa) minimum yield strength, 65ksi (450MPa) minimum tensile strength with ASTM A653/A653M G60 (Z180) hot dipped galvanized coating.

Benefits That Add Value:

Weight Advantages

- Lighter weight results in easier handling & shipping efficiencies
- Reduction of wall mass & labor costs
- 80% lighter than concrete/masonry block, optimizing foundation thickness

Fastener Efficiencies

- Screw size decreases with thinner material thickness of member material, facilitating faster connections
- Larger flange width increases area for fasteners

Performance Improvements

- Increased load capacity over similar standard "C-shaped" stud (14ga "C-shaped" to 18ga "SG" common)
- May eliminate double studs and their attachments to each other
- Compatible with all common types of floor systems and designs
- Accelerate construction schedules

Engineering Advantages

- Axial load capacity tables compatible with recent code changes

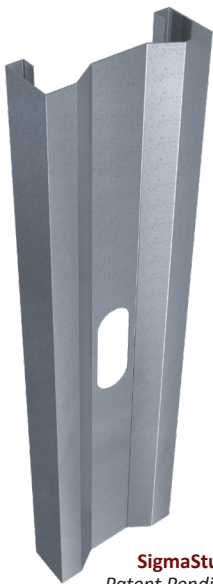

SigmaStud®
Patent Pending

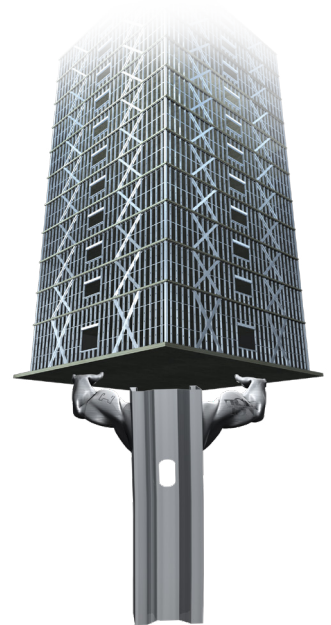

Design Comparison of SigmaStud® and Standard "C-Shape" Studs

Design Assumptions: Wall height: 9 feet; Bridging at 48" o.c. (vertically); Stud Spacing at 16" o.c.; Single or Back-to-Back Members Only; L/180 Deflection; $F_y = 50$ ksi for Both C-Shape and SigmaStud; 5 psf Lateral Load; No Load Reductions Taken.

Axial Load	"C" Shape, 1 5/8" Flange	"C" Shape, 2" Flange	SigmaStud® Section	Comparison Conclusion
↓				
4k	600S162-54	600S200-43	600SG162-33	The data presents tangible examples of the exceptional value SigmaStud provides for designers, installers, and owners. In each case, SigmaStud represents a thinner and lighter option, resulting in significant material and labor efficiencies. As the axial load increases, the differences between a single member and 2 or even 3 "ganged" members become even more evident. The ganged members should be connected, either back-to-back or lip-to-lip. Back-to-back ganged studs are connected with either an engineered weld, flat strap and screws along the flanges, or screws through each web placed vertically at 24" o.c. (typical). Use of a single SigmaStud section eliminates the additional engineering as well as the installation of these elements. Contact TSN's technical support team for design recommendations.
8k	600S162-97	600S200-68	600SG200-43	
12k	(2) 600S162-54	600S200-97	600SG250-54	
16k	(2) 600S162-68	(2) 600S200-54	600SG250-68	
20k	(2) 600S162-97	(2) 600S200-68	600SG250-97	
24k	(2) 600S162-97	(2) 600S200-97	600SG250-97 or (2) 600SG250-54	
30k	(3) 600S162-97	(2) 600S200-97	600SG300-118 or (2) 600SG250-68	

Load Bearing Wall Members

SigmaStud® Product Profile

Important Notes

1. Section properties and capacities are calculated in accordance with AISI S100-07 with 2010 supplement.
2. Tabulated gross properties are based on the full-unreduced cross section of the studs, away from punchouts.
3. Effective section properties incorporate the strength increase from the cold-work of forming as applicable per AISI S100-07 Sec. A7.2.
4. Net effective section properties are calculated at a cross section through the punchout.
5. Allowable moment is the lesser of M_{al} and M_{ad} . Stud distortional buckling is based on an assumed $k_{\phi} = 0$.
6. For deflection calculations, use the effective moment of inertia.
7. The effective moment of inertia for deflection is calculated at a stress which results in a section modulus such that the stress times the section modulus at that stress is equal to the allowable moment. AISI S100-07 Procedure I for serviceability determination has been used.

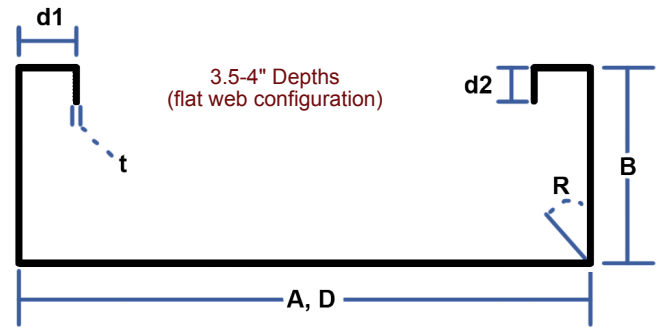

SigmaStud® Product Profile: 3-1/2" - 4" Stud Depths

Section (All 50 ksi)	Overall Depth	Flange Width	Web Flat	Web Return	Web Return	Web Inside	Return Lip 1	Return Lip 2	Inside Bend Radius	Design Thickness	Unit Weight
	D	B	A	C	E	N	d1	d2	R	t	
	(in)	(in)	(in)	(in)	(in)	(in)	(in)	(in)	(in)	(in)	(lb/ft)
350SG200-33	3.5	2	3.5	0	0	0	0.5892	0.5	0.105	0.0346	1.078
350SG200-43	3.5	2	3.5	0	0	0	0.6102	0.5	0.105	0.0451	1.400
350SG200-54	3.5	2	3.5	0	0	0	0.6332	0.5	0.105	0.0566	1.749
350SG200-68	3.5	2	3.5	0	0	0	0.6626	0.5	0.105	0.0713	2.192
350SG200-97	3.5	2	3.5	0	0	0	0.7234	0.5	0.105	0.1017	3.092
350SG250-43	3.5	2.5	3.5	0	0	0	0.6102	0.5	0.105	0.0451	1.553
350SG250-54	3.5	2.5	3.5	0	0	0	0.6332	0.5	0.105	0.0566	1.942
350SG250-68	3.5	2.5	3.5	0	0	0	0.6626	0.5	0.105	0.0713	2.435
350SG250-97	3.5	2.5	3.5	0	0	0	0.7234	0.5	0.105	0.1017	3.438
350SG300-54	3.5	3	3.5	0	0	0	0.6332	0.5	0.105	0.0566	2.135
350SG300-68	3.5	3	3.5	0	0	0	0.6626	0.5	0.105	0.0713	2.678
350SG300-97	3.5	3	3.5	0	0	0	0.7234	0.5	0.105	0.1017	3.785
350SG350-68	3.5	3.5	3.5	0	0	0	0.6626	0.5	0.105	0.0713	2.920
362SG200-33	3.625	2	3.625	0	0	0	0.5892	0.5	0.105	0.0346	1.093
362SG200-43	3.625	2	3.625	0	0	0	0.6102	0.5	0.105	0.0451	1.419
362SG200-54	3.625	2	3.625	0	0	0	0.6332	0.5	0.105	0.0566	1.773
362SG200-68	3.625	2	3.625	0	0	0	0.6626	0.5	0.105	0.0713	2.222
362SG200-97	3.625	2	3.625	0	0	0	0.7234	0.5	0.105	0.1017	3.135
362SG250-43	3.625	2.5	3.625	0	0	0	0.6102	0.5	0.105	0.0451	1.572
362SG250-54	3.625	2.5	3.625	0	0	0	0.6332	0.5	0.105	0.0566	1.966
362SG250-68	3.625	2.5	3.625	0	0	0	0.6626	0.5	0.105	0.0713	2.465
362SG250-97	3.625	2.5	3.625	0	0	0	0.7234	0.5	0.105	0.1017	3.481
362SG300-54	3.625	3	3.625	0	0	0	0.6332	0.5	0.105	0.0566	2.159
362SG300-68	3.625	3	3.625	0	0	0	0.6626	0.5	0.105	0.0713	2.708
362SG300-97	3.625	3	3.625	0	0	0	0.7234	0.5	0.105	0.1017	3.828
362SG350-68	3.625	3.5	3.625	0	0	0	0.6626	0.5	0.105	0.0713	2.950
400SG200-33	4	2	4	0	0	0	0.5892	0.5	0.105	0.0346	1.137
400SG200-43	4	2	4	0	0	0	0.6102	0.5	0.105	0.0451	1.477
400SG200-54	4	2	4	0	0	0	0.6332	0.5	0.105	0.0566	1.846
400SG200-68	4	2	4	0	0	0	0.6626	0.5	0.105	0.0713	2.313
400SG200-97	4	2	4	0	0	0	0.7234	0.5	0.105	0.1017	3.265
400SG250-43	4	2.5	4	0	0	0	0.6102	0.5	0.105	0.0451	1.630
400SG250-54	4	2.5	4	0	0	0	0.6332	0.5	0.105	0.0566	2.038
400SG250-68	4	2.5	4	0	0	0	0.6626	0.5	0.105	0.0713	2.556
400SG250-97	4	2.5	4	0	0	0	0.7234	0.5	0.105	0.1017	3.611
400SG300-54	4	3	4	0	0	0	0.6332	0.5	0.105	0.0566	2.231
400SG300-68	4	3	4	0	0	0	0.6626	0.5	0.105	0.0713	2.799
400SG300-97	4	3	4	0	0	0	0.7234	0.5	0.105	0.1017	3.958
400SG350-68	4	3.5	4	0	0	0	0.6626	0.5	0.105	0.0713	3.041
400SG350-97	4	3.5	4	0	0	0	0.7234	0.5	0.105	0.1017	4.303
400SG350-118	4	3.5	4	0	0	0	0.7684	0.5	0.105	0.1242	5.216

Load Bearing Wall Members

SigmaStud® Product Profile

Important Notes

1. Section properties and capacities are calculated in accordance with AISI S100-07 with 2010 supplement.
2. Tabulated gross properties are based on the full-unreduced cross section of the studs, away from punchouts.
3. Effective section properties incorporate the strength increase from the cold-work of forming as applicable per AISI S100-07 Sec. A7.2.
4. Net effective section properties are calculated at a cross section through the punchout.
5. Allowable moment is the lesser of M_{al} and M_{ad} . Stud distortional buckling is based on an assumed $k_{\phi} = 0$.
6. For deflection calculations, use the effective moment of inertia.
7. The effective moment of inertia for deflection is calculated at a stress which results in a section modulus such that the stress times the section modulus at that stress is equal to the allowable moment. AISI S100-07 Procedure I for serviceability determination has been used.

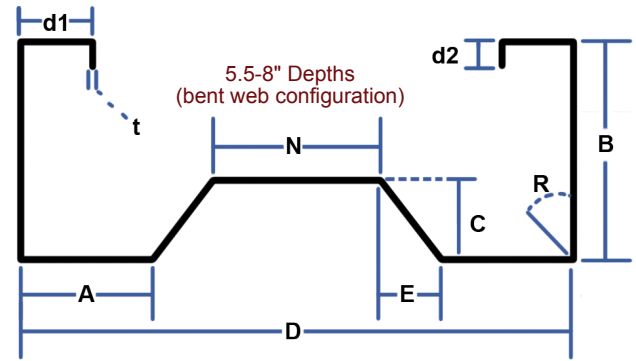

SigmaStud® Product Profile: 5-1/2" - 8" Stud Depths											
Section (All 50 ksi)	Overall Depth	Flange Width	Web Flat	Web Return	Web Return	Web Inside	Return Lip 1	Return Lip 2	Inside Bend Radius	Design Thickness	Unit Weight
	D (in)	B (in)	A (in)	C (in)	E (in)	N (in)	d1 (in)	d2 (in)	R (in)	t (in)	(lb/ft)
550SG162-33	5.5	1.625	1	1	0.625	2.25	0.5	0	0.105	0.0346	1.232
550SG162-43	5.5	1.625	1	1	0.625	2.25	0.5	0	0.105	0.0451	1.598
550SG162-54	5.5	1.625	1	1	0.625	2.25	0.5	0	0.105	0.0566	1.994
550SG162-68	5.5	1.625	1	1	0.625	2.25	0.5	0	0.105	0.0713	2.494
550SG200-33	5.5	2	1	1	0.625	2.25	0.5892	0.5	0.105	0.0346	1.438
550SG200-43	5.5	2	1	1	0.625	2.25	0.6102	0.5	0.105	0.0451	1.869
550SG200-54	5.5	2	1	1	0.625	2.25	0.6332	0.5	0.105	0.0566	2.338
550SG200-68	5.5	2	1	1	0.625	2.25	0.6626	0.5	0.105	0.0713	2.933
550SG200-97	5.5	2	1	1	0.625	2.25	0.7234	0.5	0.105	0.1017	4.147
550SG250-43	5.5	2.5	1	1	0.625	2.25	0.6102	0.5	0.105	0.0451	2.023
550SG250-54	5.5	2.5	1	1	0.625	2.25	0.6332	0.5	0.105	0.0566	2.531
550SG250-68	5.5	2.5	1	1	0.625	2.25	0.6626	0.5	0.105	0.0713	3.176
550SG250-97	5.5	2.5	1	1	0.625	2.25	0.7234	0.5	0.105	0.1017	4.493
550SG300-43	5.5	3	1	1	0.625	2.25	0.6102	0.5	0.105	0.0451	2.176
550SG300-54	5.5	3	1	1	0.625	2.25	0.6332	0.5	0.105	0.0566	2.723
550SG300-68	5.5	3	1	1	0.625	2.25	0.6626	0.5	0.105	0.0713	3.418
550SG300-97	5.5	3	1	1	0.625	2.25	0.7234	0.5	0.105	0.1017	4.839
550SG300-118	5.5	3	1	1	0.625	2.25	0.7684	0.5	0.105	0.1242	5.867
600SG162-33	6	1.625	1.25	1	0.625	2.25	0.5	0	0.105	0.0346	1.291
600SG162-43	6	1.625	1.25	1	0.625	2.25	0.5	0	0.105	0.0451	1.674
600SG162-54	6	1.625	1.25	1	0.625	2.25	0.5	0	0.105	0.0566	2.090
600SG162-68	6	1.625	1.25	1	0.625	2.25	0.5	0	0.105	0.0713	2.615
600SG200-33	6	2	1.25	1	0.625	2.25	0.5892	0.5	0.105	0.0346	1.497
600SG200-43	6	2	1.25	1	0.625	2.25	0.6102	0.5	0.105	0.0451	1.946
600SG200-54	6	2	1.25	1	0.625	2.25	0.6332	0.5	0.105	0.0566	2.435
600SG200-68	6	2	1.25	1	0.625	2.25	0.6626	0.5	0.105	0.0713	3.054
600SG200-97	6	2	1.25	1	0.625	2.25	0.7234	0.5	0.105	0.1017	4.320
600SG250-43	6	2.5	1.25	1	0.625	2.25	0.6102	0.5	0.105	0.0451	2.100
600SG250-54	6	2.5	1.25	1	0.625	2.25	0.6332	0.5	0.105	0.0566	2.627
600SG250-68	6	2.5	1.25	1	0.625	2.25	0.6626	0.5	0.105	0.0713	3.297
600SG250-97	6	2.5	1.25	1	0.625	2.25	0.7234	0.5	0.105	0.1017	4.666
600SG300-43	6	3	1.25	1	0.625	2.25	0.6102	0.5	0.105	0.0451	2.253
600SG300-54	6	3	1.25	1	0.625	2.25	0.6332	0.5	0.105	0.0566	2.820
600SG300-68	6	3	1.25	1	0.625	2.25	0.6626	0.5	0.105	0.0713	3.540
600SG300-97	6	3	1.25	1	0.625	2.25	0.7234	0.5	0.105	0.1017	5.012
600SG300-118	6	3	1.25	1	0.625	2.25	0.7684	0.5	0.105	0.1242	6.078
800SG162-33	8	1.625	2.25	1	0.625	2.25	0.5	0	0.105	0.0346	1.526
800SG162-43	8	1.625	2.25	1	0.625	2.25	0.5	0	0.105	0.0451	1.981
800SG162-54	8	1.625	2.25	1	0.625	2.25	0.5	0	0.105	0.0566	2.475
800SG162-68	8	1.625	2.25	1	0.625	2.25	0.5	0	0.105	0.0713	3.100
800SG200-33	8	2	2.25	1	0.625	2.25	0.5892	0.5	0.105	0.0346	1.733
800SG200-43	8	2	2.25	1	0.625	2.25	0.6102	0.5	0.105	0.0451	2.253
800SG200-54	8	2	2.25	1	0.625	2.25	0.6332	0.5	0.105	0.0566	2.820
800SG200-68	8	2	2.25	1	0.625	2.25	0.6626	0.5	0.105	0.0713	3.540
800SG200-97	8	2	2.25	1	0.625	2.25	0.7234	0.5	0.105	0.1017	5.012
800SG250-43	8	2.5	2.25	1	0.625	2.25	0.6102	0.5	0.105	0.0451	2.406
800SG250-54	8	2.5	2.25	1	0.625	2.25	0.6332	0.5	0.105	0.0566	3.012
800SG250-68	8	2.5	2.25	1	0.625	2.25	0.6626	0.5	0.105	0.0713	3.782
800SG250-97	8	2.5	2.25	1	0.625	2.25	0.7234	0.5	0.105	0.1017	5.358
800SG300-43	8	3	2.25	1	0.625	2.25	0.6102	0.5	0.105	0.0451	2.560
800SG300-54	8	3	2.25	1	0.625	2.25	0.6332	0.5	0.105	0.0566	3.205
800SG300-68	8	3	2.25	1	0.625	2.25	0.6626	0.5	0.105	0.0713	4.025
800SG300-97	8	3	2.25	1	0.625	2.25	0.7234	0.5	0.105	0.1017	5.704
800SG300-118	8	3	2.25	1	0.625	2.25	0.7684	0.5	0.105	0.1242	6.922

Important Notes

1. Section properties and capacities are calculated in accordance with AISI S100-16/S2-20, "North American Specification for the Design of Cold-Formed Steel Structural Members".
2. Effective section properties incorporate the strength increase from the cold-work of forming as applicable per AISI S100-16/S2-20, Sec. A3.3.2 (3).
3. Tabulated gross properties are based on the full-unreduced cross section of the studs, away from punchouts.
4. Allowable moment is the lesser of (M_{al}, M_{ad}) for solid sections or the lesser of (M_{al}(net), M_{ad}(net)) for punched sections. Stud distortional buckling is based on an assumed k_f = 0.
5. For deflection calculations, use the effective moment of inertia.
6. The effective moment of inertia for deflection is calculated at a stress which results in a section modulus such that the stress times the section modulus at that stress is equal to the allowable moment. AISI S100-16/S2-20 Procedure I for serviceability determination has been used.

SigmaStud® Section Properties - Straight Web																						
Section (All 50 ksi)	Gross Properties						Torsional Properties						Effective Properties 50 ksi									
	Area (in ²)	I _x (in ⁴)	S _x (in ³)	R _x (in)	I _y (in ⁴)	R _y (in)	Jx10 ¹⁰ (in ⁴)	C _w (in ⁶)	X _o (in)	m (in)	R _o (in)	β	A _o (net) (in ²)	I _{xe} (in ⁴)	S _{xe} (in ³)	S _{xe} (net) (in ³)	M _{al} (in-k)	M _{al} (net) (in-k)	M _{ad} (in-k)	M _{ad} (net) (in-k)	V _a (lbs)	V _a (net) (lbs)
350SG200-33	0.317	0.630	0.360	1.410	0.194	0.782	0.126	0.718	-1.975	1.178	2.549	0.400	0.201	0.615	0.310	0.283	9.295	8.479	8.570	8.332	1144	527
350SG200-43	0.411	0.810	0.463	1.404	0.249	0.779	0.279	0.929	-1.969	1.176	2.541	0.399	0.293	0.810	0.430	0.406	12.878	12.161	12.176	11.825	2141	747
350SG200-54	0.514	1.003	0.573	1.397	0.309	0.775	0.549	1.158	-1.963	1.173	2.531	0.398	0.384	1.003	0.550	0.530	16.470	15.871	16.295	15.825	3371	925
350SG200-68	0.644	1.241	0.709	1.388	0.382	0.770	1.091	1.444	-1.955	1.169	2.519	0.397	0.529	1.241	0.709	0.696	23.531	20.831	23.373	20.636	4208	900
350SG200-97	0.909	1.705	0.974	1.370	0.525	0.760	3.132	2.017	-1.938	1.160	2.492	0.395	0.756	1.705	0.974	0.958	33.387	32.831	33.387	32.827	5886	850
350SG250-43	0.456	0.945	0.540	1.439	0.424	0.964	0.309	1.565	-2.471	1.445	3.017	0.329	0.292	0.933	0.447	0.418	13.371	12.505	13.045	12.687	2141	747
350SG250-54	0.571	1.171	0.669	1.432	0.526	0.960	0.609	1.953	-2.465	1.442	3.008	0.329	0.383	1.171	0.571	0.545	17.099	16.324	17.616	17.120	3371	925
350SG250-68	0.715	1.450	0.829	1.424	0.653	0.955	1.212	2.443	-2.457	1.439	2.996	0.328	0.519	1.450	0.748	0.728	22.400	21.809	23.675	23.014	4208	900
350SG250-97	1.010	1.999	1.142	1.406	0.904	0.946	3.483	3.431	-2.441	1.430	2.972	0.325	0.835	1.999	1.125	1.107	37.597	37.005	38.177	37.438	5886	850
350SG300-54	0.627	1.338	0.765	1.461	0.814	1.139	0.670	2.996	-2.964	1.707	3.496	0.281	0.387	1.296	0.592	0.562	17.731	16.815	18.670	18.163	3371	925
350SG300-68	0.787	1.660	0.949	1.453	1.013	1.135	1.333	3.753	-2.957	1.704	3.485	0.280	0.530	1.648	0.782	0.757	23.418	22.673	25.307	24.608	4208	900
350SG300-97	1.112	2.292	1.310	1.436	1.408	1.125	3.834	5.289	-2.942	1.696	3.461	0.278	0.877	2.292	1.241	1.219	37.150	36.512	39.215	38.196	5886	850
350SG350-68	0.858	1.870	1.068	1.476	1.471	1.309	1.454	5.401	-3.456	1.965	3.980	0.246	0.535	1.812	0.804	0.774	24.073	23.179	26.651	25.932	4208	900
362SG200-33	0.321	0.683	0.377	1.459	0.196	0.782	0.128	0.759	-1.954	1.168	2.561	0.418	0.202	0.668	0.326	0.295	9.754	8.842	8.919	8.673	1102	544
362SG200-43	0.417	0.879	0.485	1.452	0.253	0.779	0.283	0.983	-1.948	1.166	2.552	0.417	0.293	0.879	0.451	0.424	13.504	12.690	12.685	12.320	2141	802
362SG200-54	0.521	1.089	0.601	1.445	0.313	0.775	0.556	1.224	-1.942	1.163	2.542	0.416	0.385	1.089	0.577	0.553	17.261	16.571	16.994	16.504	3372	994
362SG200-68	0.653	1.348	0.744	1.437	0.388	0.770	1.107	1.526	-1.934	1.159	2.530	0.415	0.532	1.348	0.744	0.728	24.678	21.799	24.401	21.653	4375	1007
362SG200-97	0.921	1.854	1.023	1.419	0.533	0.761	3.176	2.130	-1.918	1.150	2.504	0.413	0.769	1.854	1.023	1.007	35.050	34.514	35.050	34.509	6124	954
362SG250-43	0.462	1.024	0.565	1.489	0.430	0.964	0.313	1.656	-2.447	1.435	3.023	0.344	0.293	1.011	0.468	0.435	14.012	13.038	13.565	13.194	2141	802
362SG250-54	0.578	1.269	0.700	1.482	0.533	0.961	0.617	2.066	-2.442	1.432	3.014	0.344	0.385	1.269	0.598	0.569	17.908	17.031	18.335	17.821	3372	994
362SG250-68	0.724	1.573	0.868	1.474	0.662	0.956	1.227	2.583	-2.434	1.428	3.002	0.342	0.522	1.573	0.783	0.761	23.449	22.775	24.670	23.982	4375	1007
362SG250-97	1.023	2.169	1.197	1.456	0.916	0.946	3.527	3.625	-2.418	1.420	2.977	0.340	0.848	2.169	1.178	1.161	39.389	38.814	40.011	39.252	6124	954
362SG300-54	0.634	1.449	0.800	1.511	0.825	1.141	0.677	3.170	-2.940	1.696	3.497	0.293	0.389	1.403	0.620	0.586	18.563	17.535	19.402	18.878	3372	994
362SG300-68	0.796	1.798	0.992	1.503	1.027	1.136	1.348	3.970	-2.932	1.693	3.486	0.292	0.533	1.785	0.818	0.791	24.504	23.668	26.327	25.602	4375	1007
362SG300-97	1.125	2.485	1.371	1.486	1.427	1.126	3.877	5.590	-2.917	1.685	3.462	0.290	0.889	2.485	1.298	1.277	38.863	38.235	41.048	39.985	6124	954
362SG350-68	0.867	2.023	1.116	1.528	1.491	1.311	1.469	5.715	-3.430	1.954	3.977	0.256	0.538	1.961	0.841	0.808	25.186	24.190	27.689	26.946	4375	1007
400SG200-33	0.334	0.859	0.429	1.603	0.204	0.782	0.133	0.895	-1.894	1.139	2.602	0.470	0.202	0.842	0.373	0.332	11.168	9.928	9.971	9.701	991	589
400SG200-43	0.434	1.107	0.553	1.597	0.263	0.778	0.294	1.157	-1.889	1.136	2.593	0.469	0.295	1.107	0.515	0.477	15.429	14.276	14.220	13.817	2141	967
400SG200-54	0.542	1.371	0.686	1.590	0.325	0.775	0.579	1.440	-1.883	1.133	2.583	0.469	0.389	1.371	0.658	0.624	19.693	18.673	19.109	18.562	3372	1201
400SG200-68	0.680	1.700	0.850	1.581	0.403	0.770	1.152	1.794	-1.875	1.129	2.571	0.468	0.540	1.700	0.850	0.825	28.202	24.708	27.517	24.756	4876	1360
400SG200-97	0.959	2.344	1.172	1.563	0.555	0.760	3.308	2.498	-1.858	1.121	2.544	0.467	0.806	2.344	1.172	1.158	40.162	34.664	40.162	34.659	6839	1299
400SG250-43	0.479	1.283	0.641	1.637	0.446	0.965	0.325	1.951	-2.381	1.404	3.046	0.389	0.294	1.268	0.534	0.489	15.981	14.635	15.133	14.726	2141	967
400SG250-54	0.599	1.591	0.796	1.630	0.554	0.962	0.640	2.432	-2.375	1.401	3.037	0.388	0.388	1.591	0.681	0.640	20.397	19.150	20.506	19.938	3372	1201
400SG250-68	0.751	1.975	0.987	1.622	0.688	0.957	1.273	3.038	-2.368	1.398	3.025	0.387	0.530	1.975	0.891	0.858	26.669	25.675	27.679	26.913	4876	1360
400SG250-97	1.061	2.730	1.365	1.604	0.953	0.948	3.658	4.255	-2.352	1.390	3.000	0.386	0.908	2.730	1.343	1.351	44.884	40.448	45.635	40.443	6839	1299
400SG300-54	0.656	1.811	0.906	1.662	0.857	1.143	0.700	3.736	-2.868	1.665	3.506	0.331	0.392	1.755	0.705	0.658	21.123	19.694	21.611	21.036	3372	1201
400SG300-68	0.822	2.250	1.125	1.654	1.067	1.139	1.394	4.674	-2.861	1.661	3.495	0.330	0.541	2.235	0.930	0.890	27.841	26.652	29.405	28.605	4876	1360
400SG300-97	1.163	3.117	1.558	1.637	1.483	1.129	4.009	6.569	-2.845	1.654	3.471	0.328	0.927	3.117	1.473	1.453	44.109	43.508	46.248	45.045	6839	1299
400SG350-68	0.894	2.525	1.263	1.681	1.547	1.316	1.514	6.736	-3.354	1.922	3.976	0.288	0.545	2.447	0.955	0.909	28.602	27.223	30.817	30.002	4876	1360
400SG350-97	1.265	3.503	1.751	1.664	2.158	1.306	4.360	9.488	-3.339	1.915	3.953	0.286	0.917	3.483	1.502	1.473	44.961	44.092	49.104	47.809	6839	1299
400SG350-118	1.533	4.184	2.092	1.652	2.587	1.299	7.855	11.458	-3.328	1.909	3.936	0.285	1.235	4.184	1.980	1.955	59.268	58.533	62.640	61.275	8235	1256

Refer to Important Table Notes on Page 5

SigmaStud® Section Properties																						
Section (All 50 ksi)	Gross Properties						Torsional Properties						Effective Properties 50 ksi									
	Area (in²)	I _x (in⁴)	S _x (in³)	R _x (in)	I _y (in⁴)	R _y (in)	Jx10⁹ (in⁴)	C _w (in⁶)	X _o (in)	m (in)	R _o (in)	β	A _{e(net)} (in²)	I _{xe} (in⁴)	S _{xe} (in³)	S _{xe(net)} (in³)	M _{al} (in-k)	M _{al(net)} (in-k)	M _{ad} (in-k)	M _{ad(net)} (in-k)	V _a (lb)	V _{a(net)} (lb)
550SG162-33	0.362	1.522	0.554	2.051	0.096	0.514	0.144	0.864	-0.203	0.495	2.124	0.991	0.262	1.522	0.499	0.492	14.933	14.728	11.731	11.263	996	586
550SG162-43	0.469	1.963	0.714	2.045	0.122	0.510	0.318	1.097	-0.191	0.504	2.116	0.992	0.366	1.963	0.663	0.656	19.864	19.632	16.926	16.198	2141	953
550SG162-54	0.586	2.434	0.885	2.038	0.150	0.506	0.626	1.338	-0.178	0.514	2.108	0.993	0.484	2.434	0.855	0.847	28.406	28.147	24.685	23.538	3372	1176
550SG162-68	0.733	3.020	1.098	2.030	0.184	0.501	1.242	1.624	-0.162	0.526	2.097	0.994	0.626	3.020	1.093	1.085	37.052	36.790	34.068	32.424	4793	1298
550SG200-33	0.423	1.882	0.684	2.110	0.175	0.643	0.169	1.783	-0.716	0.160	2.319	0.905	0.316	1.859	0.609	0.602	18.245	18.026	14.840	14.464	996	586
550SG200-43	0.549	2.432	0.884	2.104	0.225	0.640	0.372	2.294	-0.708	0.165	2.310	0.906	0.449	2.432	0.833	0.826	24.953	24.737	21.359	20.787	2141	953
550SG200-54	0.687	3.023	1.099	2.097	0.278	0.636	0.734	2.838	-0.700	0.172	2.301	0.907	0.577	3.023	1.059	1.051	31.695	31.454	28.982	28.186	3372	1176
550SG200-68	0.862	3.761	1.368	2.089	0.344	0.631	1.460	3.510	-0.689	0.180	2.289	0.909	0.755	3.761	1.368	1.362	45.387	45.201	42.130	40.928	4793	1298
550SG200-97	1.219	5.229	1.901	2.072	0.471	0.622	4.201	4.816	-0.667	0.197	2.263	0.913	1.066	5.229	1.901	1.894	65.164	64.924	65.164	64.762	6657	1207
550SG250-43	0.594	2.767	1.006	2.158	0.389	0.809	0.403	3.788	-1.149	0.104	2.575	0.801	0.448	2.752	0.860	0.848	25.753	25.402	22.319	21.755	2141	953
550SG250-54	0.744	3.442	1.252	2.151	0.483	0.806	0.794	4.701	-1.141	0.098	2.565	0.802	0.576	3.442	1.093	1.079	32.714	32.302	30.488	29.686	3372	1176
550SG250-68	0.933	4.286	1.559	2.143	0.599	0.801	1.581	5.835	-1.131	0.090	2.552	0.804	0.745	4.286	1.419	1.405	42.488	42.052	41.569	40.458	4793	1298
550SG250-97	1.320	5.970	2.171	2.126	0.826	0.791	4.552	8.069	-1.108	0.073	2.525	0.807	1.143	5.970	2.137	2.124	71.427	71.012	71.151	69.241	6657	1207
550SG300-43	0.639	3.103	1.128	2.203	0.622	0.987	0.434	5.742	-1.597	0.369	2.894	0.695	0.445	2.995	0.876	0.860	26.232	25.746	23.034	22.484	2141	953
550SG300-54	0.800	3.861	1.404	2.197	0.773	0.983	0.855	7.139	-1.589	0.363	2.884	0.696	0.580	3.739	1.129	1.111	33.808	33.249	31.625	30.830	3372	1176
550SG300-68	1.004	4.812	1.750	2.189	0.960	0.978	1.702	8.883	-1.579	0.355	2.870	0.697	0.756	4.770	1.477	1.457	44.224	43.615	43.406	42.278	4793	1298
550SG300-97	1.422	6.711	2.440	2.172	1.332	0.968	4.902	12.348	-1.557	0.340	2.843	0.700	1.187	6.711	2.313	2.296	69.252	68.742	69.483	67.704	6657	1207
550SG300-118	1.724	8.048	2.927	2.161	1.590	0.960	8.837	14.766	-1.541	0.328	2.822	0.702	1.462	8.048	2.816	2.798	94.018	93.399	96.698	94.218	7956	1142
600SG162-33	0.379	1.854	0.618	2.211	0.104	0.523	0.151	1.090	-0.234	0.432	2.284	0.990	0.279	1.854	0.558	0.552	16.714	16.516	12.720	12.230	878	634
600SG162-43	0.492	2.392	0.797	2.205	0.133	0.519	0.334	1.386	-0.222	0.441	2.276	0.990	0.388	2.392	0.742	0.734	22.211	21.988	18.413	17.644	1959	1073
600SG162-54	0.614	2.968	0.989	2.198	0.163	0.515	0.656	1.692	-0.210	0.450	2.268	0.991	0.512	2.968	0.956	0.948	31.744	31.499	26.924	25.704	3372	1452
600SG162-68	0.768	3.684	1.228	2.190	0.200	0.510	1.302	2.058	-0.193	0.463	2.257	0.993	0.661	3.684	1.222	1.215	41.410	41.167	37.300	35.533	5352	1797
600SG200-33	0.440	2.291	0.764	2.282	0.187	0.653	0.176	2.203	-0.744	0.097	2.487	0.910	0.333	2.267	0.682	0.675	20.426	20.213	16.201	15.800	878	634
600SG200-43	0.572	2.962	0.987	2.276	0.241	0.650	0.388	2.837	-0.737	0.102	2.479	0.912	0.472	2.962	0.932	0.925	27.897	27.690	23.374	22.760	1959	1073
600SG200-54	0.715	3.683	1.228	2.269	0.299	0.646	0.764	3.513	-0.729	0.108	2.469	0.913	0.605	3.683	1.183	1.175	35.406	35.176	31.797	30.937	3372	1452
600SG200-68	0.898	4.586	1.529	2.261	0.370	0.642	1.521	4.350	-0.719	0.116	2.457	0.914	0.791	4.586	1.529	1.524	50.735	50.565	46.332	45.025	5352	1797
600SG200-97	1.269	6.386	2.129	2.243	0.508	0.633	4.376	5.980	-0.697	0.133	2.432	0.918	1.117	6.386	2.129	2.122	72.948	72.729	72.948	72.305	7610	1726
600SG250-43	0.617	3.362	1.121	2.334	0.413	0.818	0.418	4.633	-1.173	0.165	2.737	0.816	0.471	3.347	0.961	0.950	28.776	28.429	24.389	23.785	1959	1073
600SG250-54	0.772	4.183	1.394	2.328	0.513	0.815	0.824	5.752	-1.165	0.160	2.728	0.818	0.604	4.183	1.220	1.206	36.527	36.119	33.384	32.520	3372	1452
600SG250-68	0.969	5.213	1.738	2.320	0.636	0.810	1.642	7.145	-1.155	0.152	2.715	0.819	0.780	5.213	1.583	1.569	47.392	46.964	45.633	44.428	5352	1797
600SG250-97	1.371	7.270	2.423	2.303	0.879	0.800	4.727	9.893	-1.133	0.137	2.688	0.822	1.195	7.270	2.384	2.372	79.689	79.298	78.437	76.343	7610	1726
600SG300-43	0.662	3.761	1.254	2.384	0.655	0.995	0.449	6.972	-1.616	0.429	3.047	0.719	0.468	3.641	0.979	0.963	29.313	28.824	25.131	24.543	1959	1073
600SG300-54	0.829	4.683	1.561	2.377	0.814	0.991	0.885	8.670	-1.608	0.424	3.036	0.720	0.608	4.542	1.260	1.242	37.738	37.177	34.564	33.711	3372	1452
600SG300-68	1.040	5.840	1.947	2.369	1.012	0.986	1.763	10.793	-1.598	0.417	3.023	0.721	0.791	5.795	1.647	1.627	49.312	48.703	47.543	46.327	5352	1797
600SG300-97	1.473	8.155	2.718	2.353	1.404	0.976	5.078	15.015	-1.577	0.402	2.996	0.723	1.238	8.155	2.575	2.559	77.106	76.610	76.434	74.491	7610	1726
600SG300-118	1.786	9.789	3.263	2.341	1.678	0.969	9.154	17.967	-1.562	0.391	2.976	0.725	1.525	9.789	3.138	3.120	104.762	104.165	106.616	103.892	9118	1649
800SG162-33	0.448	3.631	0.908	2.845	0.130	0.538	0.179	2.193	-0.302	0.261	2.912	0.989	0.299	3.631	0.755	0.745	22.609	22.305	16.445	15.895	595	595
800SG162-43	0.582	4.691	1.173	2.839	0.166	0.534	0.395	2.796	-0.292	0.269	2.903	0.990	0.442	4.691	1.057	1.048	31.655	31.388	24.107	23.217	1324	1268
800SG162-54	0.727	5.829	1.457	2.831	0.205	0.531	0.777	3.424	-0.280	0.278	2.894	0.991	0.613	5.829	1.425	1.420	42.670	42.505	33.345	32.019	2632	1994
800SG162-68	0.911	7.250	1.812	2.821	0.252	0.526	1.544	4.180	-0.265	0.289	2.882	0.992	0.804	7.250	1.802	1.796	61.069	60.881	50.061	47.878	5300	3156
800SG200-33	0.509	4.453	1.113	2.957	0.230	0.672	0.203	4.278	-0.791	0.064	3.134	0.936	0.353	4.432	0.931	0.920	27.875	27.559	21.591	21.107	595	595
800SG200-43	0.662	5.765	1.441	2.951	0.296	0.669	0.449	5.516	-0.784	0.059	3.126	0.937	0.525	5.765	1.327	1.319	39.722	39.476	31.423	30.667	1324	1268
800SG200-54	0.829	7.181	1.795	2.944	0.367	0.666	0.885	6.840	-0.777	0.054	3.117	0.938	0.703	7.181	1.731	1.725	51.839	51.640	43.141	42.055	2632	1994
800SG200-68	1.040	8.960	2.240	2.935	0.455	0.662	1.763	8.484	-0.767	0.047	3.105	0.939	0.933	8.960	2.240	2.236	74.340	74.215	63.400	61.713	5300	3156
800SG200-97	1.473	12.530	3.133	2.917	0.629	0.653	5.078	11.713	-0.748	0.033	3.081	0.941	1.320	12.530	3.133	3.128	107.352	107.192	104.064	101.327	10888	4452
800SG250-43	0.707	6.478	1.620	3.027	0.493	0.835	0.479	8.833	-1.196	0.317	3.360	0.873	0.524	6.478	1.365	1.351	40.856	40.447	32.761	32.012	1324	1268
800SG250-54	0.885	8.074	2.019	3.020	0.612	0.832	0.945	10.975	-1.189	0.312	3.350	0.874	0.702	8.074	1.783	1.770	53.382	52.985	45.165	44.076	2632	1994
800SG250-68	1.111	10.081	2.520	3.012	0.761	0.827	1.883	13.649	-1.179	0.305	3.339	0.875	0.923	10.081	2.306	2.292	69.027	68.617	62.282	60.729	5300	3156
800SG250-97	1.575	14.116	3.529	2.994	1.055	0.818	5.428	18.950	-1.160	0.292	3.314											

Table Background And Example

1. Basis For Tables:

The SigmaStud Combined Axial and Lateral Load tables in this catalog cover the following basic load combinations for the Allowable Stress Design (ASD) Method (IBC 2024 and ASCE 7-22). Listed wind pressures represent calculated design wind pressure ($0.6W$ based on 2024 IBC).

- IBC 2024 / ASCE 7-22
 - i. $D + L$ (Strength Determination)
 - ii. $D + 0.75L + 0.75(0.6W_{MWFRS}^*)$ (Strength Determination)
 - iii. $D + 0.70(0.6W_{C\&C}^{**})$ (Deflection Determination)

* MWFRS: Main Wind Force Resisting System

** C&C: Component and Cladding

- For deflection determination IBC 2024 Sec. 1604.3 and AISI S240-20 North American Standard for Cold-Formed Steel Structural Framing Sec. B1.1.2. allow for a reduction factor of 0.7 on the component and cladding wind load ($0.7W_{C\&C}$).

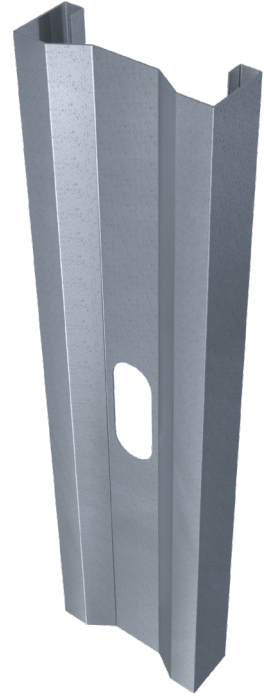

2. Design Example:

Given:

Service (Un-factored) Loads:

Axial Dead Load = 1.6 kips

Stud Spacing = 16 in. o.c.

Specified Deflection Limit = $L/360$

Bridging (Lateral Bracing) at maximum vertical spacing of 48" o.c.

Calculations:

- a) Use the $D + L$ load combination to get the first estimate of the stud.
 Combination total axial load = 1.6 kips + 3.2 kips = 4.8 kips
 From the "No Lateral Load" table with a 12 ft wall height, choose 600SG200-43 (50 ksi) with an axial resistance of 9.35 kips > 4.8 kips. **OK**
- b) Check the $D + 0.75L + 0.75(0.6W_{MWFRS})$ (IBC 2024 / ASCE 7-22) load combination for strength.
 Combination total axial load = 1.6 kips + 0.75(3.2 kips) = 4.0 kips
 $0.75(0.6W_{MWFRS}) = 0.75 \times 28 \text{ psf} = 21 \text{ psf}$ (approximately 20 psf)
 Go to the "Lateral Load = 20 psf" table with a 12 ft. wall height and 16 in. stud spacing. The axial resistance for 600SG200-43 (50 ksi) is 6.20 kips > 4.0 kips. **OK**
- c) Check the $0.70(0.6W_{C\&C})$ (IBC 2024 / ASCE 7-22) load combination for deflection.
 The specified limit is $L/360$.
 Go to the "Lateral Load = 40 psf" table with a 12 ft. wall height and 16 in. stud spacing. The deflection parameter for 600SG200-43 (50 ksi) is blank, which indicates that deflection is less than $L/720 < L/360$. **OK**

Conclusion:

Use 600SG200-43 (50 ksi) (with design thickness = 0.0451" and $F_y = 50$ ksi) spaced at 16 in. o.c. with 2 lines of bridging arranged so that the maximum spacing does not exceed 48 in. (4 ft.)

3. Extra Design Considerations:

- a) Check lateral end reaction of the stud for web crippling if applicable.
- b) If the specified axial dead load acting on the stud is significantly larger than the specified axial live load, the following basic load combination needs to be checked as well:
 - IBC 2024 / ASCE 7-22
 - i. $D + (0.6W_{C\&C})$ (Strength Determination)

Load Bearing Wall Members

Combined Axial & Lateral Load Tables

Important Notes

1. Allowable loads are based on weak axis and torsional bracing at 48" o.c. maximum for axial load calculation, and continuous support of each flange for flexural calculation.
2. Sections are punched with a standard punch-out 1.5" wide located along the centerline of the web 24" o.c.
3. Allowable loads are based on checks for punched section under axial load condition.
4. Weak axis and torsional bracing is assumed to have sufficient strength and stiffness to resist axial loads.
5. The allowable axial strength for distortional buckling is based on an assumed $k_{\phi} = 0$.
6. Strength increase due to cold forming is incorporated in calculating allowable loads as per AISI S100-16/S2-20, Sec. A3.3.2 (3).
7. Loads in tables are in kips/stud.

No Lateral Load (for Load Combination 1.0D + 1.0L): Axial Compression Load (kips)																					
Wall Height (ft)	Spacing (in) o.c.	350SG200-(mils)					350SG250-(mils)				350SG300-(mils)			350SG350-(mils)			362SG200-(mils)				
		33	43	54	68	97	43	54	68	97	54	68	97	68	33	43	54	68	97		
8	12, 16, 24	3.21	4.54	5.88	7.43	10.98	5.09	6.80	8.58	12.58	6.83	9.26	13.77	9.22	3.31	4.72	6.12	7.83	11.60		
9	12, 16, 24	3.02	4.23	5.45	6.87	10.02	4.80	6.32	7.94	11.52	6.48	8.74	12.73	8.76	3.14	4.42	5.73	7.28	10.66		
10	12, 16, 24	2.82	3.89	4.98	6.26	9.02	4.48	5.78	7.26	10.42	6.07	8.22	11.65	8.33	2.94	4.10	5.30	6.69	9.68		
12	12, 16, 24	2.37	3.19	4.02	5.03	7.12	3.72	4.69	5.87	8.28	5.31	6.68	9.41	7.20	2.51	3.40	4.34	5.44	7.70		
14	12, 16, 24	1.95	2.60	3.23	4.04	5.67	3.04	3.78	4.72	6.62	4.32	5.40	7.57	6.06	2.07	2.79	3.50	4.38	6.15		
16	12, 16, 24	1.61	2.12	2.63	3.28	4.58	2.48	3.09	3.85	5.37	3.53	4.41	6.16	4.96	1.72	2.30	2.86	3.56	4.97		

Wall Height (ft)	Spacing (in) o.c.	362SG250-(mils)				362SG300-(mils)			362SG350-(mils)	400SG200-(mils)					400SG250-(mils)				400SG300-(mils)		
		43	54	68	97	54	68	97	97	33	43	54	68	97	43	54	68	97	54	68	97
8	12, 16, 24	5.27	7.08	9.03	13.27	7.08	9.03	13.27	9.62	3.58	5.19	6.76	8.85	12.86	5.69	7.61	10.18	14.72	7.63	10.65	16.50
9	12, 16, 24	4.98	6.62	8.41	12.24	6.62	8.41	12.24	9.12	3.43	4.93	6.42	8.39	12.11	5.47	7.35	9.65	13.87	7.35	10.25	15.56
10	12, 16, 24	4.68	6.13	7.74	11.15	6.13	7.74	11.15	8.69	3.26	4.64	6.04	7.88	11.29	5.20	6.99	9.07	12.95	7.03	9.77	14.56
12	12, 16, 24	3.97	5.07	6.34	8.95	5.07	6.34	8.95	7.67	2.88	4.01	5.20	6.73	9.52	4.60	6.03	7.78	10.99	6.31	8.76	12.41
14	12, 16, 24	3.26	4.09	5.11	7.17	4.09	5.11	7.17	6.54	2.47	3.34	4.33	5.49	7.73	3.91	5.04	6.39	8.98	5.64	7.27	10.20
16	12, 16, 24	2.69	3.34	4.17	5.82	3.34	4.17	5.82	5.36	2.06	2.78	3.59	4.48	6.28	3.25	4.18	5.23	7.31	4.76	5.96	8.34

Wall Height (ft)	Spacing (in) o.c.	400SG350-(mils)			550SG162-(mils)				550SG200-(mils)					550SG250-(mils)				550SG300-(mils)				
		68	97	118	33	43	54	68	33	43	54	68	97	43	54	68	97	43	54	68	97	118
8	12, 16, 24	10.60	17.25	22.17	4.54	5.91	7.44	9.20	6.36	8.83	11.11	14.46	20.41	9.62	12.94	17.12	26.65	9.60	13.41	17.44	27.06	36.99
9	12, 16, 24	10.20	16.45	20.91	4.54	5.91	7.44	9.20	6.36	8.83	11.11	14.46	20.41	9.62	12.94	17.12	26.65	9.60	13.10	17.02	26.40	35.79
10	12, 16, 24	9.75	15.62	19.56	4.54	5.91	7.44	9.20	6.36	8.83	11.11	14.46	20.41	9.62	12.59	16.72	25.99	9.60	12.74	16.54	25.65	34.38
12	12, 16, 24	8.87	13.80	16.69	4.54	5.91	7.44	9.20	6.36	8.83	11.11	14.46	20.41	9.33	11.70	15.62	23.52	9.31	11.88	15.42	23.95	31.12
14	12, 16, 24	7.79	11.41	13.76	4.54	5.91	7.44	9.20	6.00	8.17	10.22	13.27	18.85	8.54	10.78	14.10	20.76	8.56	10.90	14.30	21.67	27.52
16	12, 16, 24	6.68	9.35	11.25	4.54	5.89	7.44	9.20	5.31	7.15	8.91	11.43	16.11	7.67	9.83	12.36	17.91	7.75	9.83	13.00	19.06	23.83

Wall Height (ft)	Spacing (in) o.c.	600SG162-(mils)				600SG200-(mils)					600SG250-(mils)				600SG300-(mils)					
		33	43	54	68	33	43	54	68	97	43	54	68	97	43	54	68	97	118	
8	12, 16, 24	4.35	6.38	8.04	9.96	6.25	9.34	11.78	15.34	21.68	9.55	13.46	17.97	27.94	9.57	13.54	18.60	28.77	39.15	
9	12, 16, 24	4.35	6.38	8.04	9.96	6.25	9.34	11.78	15.34	21.68	9.55	13.46	17.97	27.94	9.57	13.54	18.24	28.19	38.38	
10	12, 16, 24	4.35	6.38	8.04	9.96	6.25	9.34	11.78	15.34	21.68	9.55	13.46	17.95	27.94	9.57	13.54	17.81	27.51	37.14	
12	12, 16, 24	4.35	6.38	8.04	9.96	6.25	9.34	11.78	15.34	21.68	9.55	12.76	16.94	25.89	9.57	12.95	16.77	25.92	34.20	
14	12, 16, 24	4.35	6.38	8.04	9.96	6.25	9.09	11.45	14.93	21.28	9.43	11.80	15.73	23.32	9.44	12.03	15.64	24.14	30.86	
16	12, 16, 24	4.35	6.38	8.04	9.96	6.02	8.17	10.19	13.16	18.65	8.61	10.94	14.07	20.59	8.67	11.02	14.50	21.65	27.32	

Wall Height (ft)	Spacing (in) o.c.	800SG162-(mils)				800SG200-(mils)					800SG250-(mils)				800SG300-(mils)					
		33	43	54	68	33	43	54	68	97	43	54	68	97	43	54	68	97	118	
8	12, 16, 24	3.56	5.39	7.71	11.07	5.60	8.47	12.05	17.19	26.17	8.97	12.77	18.24	31.28	9.21	13.13	18.79	32.35	43.50	
9	12, 16, 24	3.56	5.39	7.71	11.07	5.60	8.47	12.05	17.19	26.17	8.97	12.77	18.24	31.28	9.21	13.13	18.79	32.35	43.50	
10	12, 16, 24	3.56	5.39	7.71	11.07	5.60	8.47	12.05	17.19	26.17	8.97	12.77	18.24	31.28	9.21	13.13	18.79	32.35	43.50	
12	12, 16, 24	3.56	5.39	7.71	11.07	5.60	8.47	12.05	17.19	26.17	8.97	12.77	18.24	31.28	9.21	13.13	18.79	32.35	43.50	
14	12, 16, 24	3.56	5.39	7.71	11.07	5.60	8.47	12.05	17.19	26.17	8.97	12.77	18.24	31.28	9.21	13.13	18.79	31.82	42.35	
16	12, 16, 24	3.56	5.39	7.71	11.07	5.60	8.47	12.05	17.19	26.17	8.97	12.77	18.24	30.07	9.21	13.13	18.79	30.21	39.55	

Load Bearing Wall Members

Combined Axial & Lateral Load Tables

Important Notes:

1. Allowable loads are based on weak axis and torsional bracing at 48" o.c. maximum for axial load calculation and continuous support of each flange for flexural calculation.
2. Sections are punched with a standard punch-out 1.5" wide located along the centerline of the web 24" o.c.
3. Allowable loads are based on checks for punched section under axial load, flexural, and shear loading conditions.
4. Weak axis and torsional bracing is assumed to have sufficient strength and stiffness to resist axial loads.
5. The allowable axial strength for distortional buckling is based on an assumed $k_y = 0$.
6. Lateral loads have not been modified for strength checks: full loads are applied.
7. Listed wind pressures represent calculated design wind pressure (0.6W based on 2024 IBC).
8. 15 psf and higher wind pressures have been multiplied by 0.7 for deflection determination, in accordance with footnote "f" of 2024 IBC Table 1604.3. The 5 psf pressure has not been reduced for deflection checks.
9. 5 psf is classified as live transverse loads, not wind loads, per 2024 IBC Section 1607.16.
10. Strength increase due to cold forming is incorporated in calculating allowable loads as per AISI S100-16/S2-20, Sec. A3.3.2 (3).
11. Moment of inertia for deflection is optimized based on the maximum moment at service loads for the listed spans. Therefore, span values may be greater than spans based on an effective moment of inertia listed in section property tables.
12. Contact The Steel Network if web crippling capacity values of SigmaStud® are required to check lateral end reactions.
13. Loads in tables are in kips/stud.
14. Cells marked with an "a", "b", "c", "d", "e", or "f" meet deflection limit L/720, L/600, L/480, L/360, L/240, or L/120 respectively. Blank cells do not meet L/120.

5 Psf Lateral Load: Axial Compression Load (kips)

Wall Height (ft)	Spacing (in) o.c.	350SG200-(mils)					350SG250-(mils)				350SG300-(mils)			350SG350-(mils)
		33	43	54	68	97	43	54	68	97	54	68	97	68
8	12	3.03 a	4.36 a	5.7 a	7.26 a	10.82 a	4.9 a	6.6 a	8.39 a	12.42 a	6.64 a	9.06 a	13.59 a	9.02 a
	16	2.96 a	4.3 a	5.64 a	7.2 a	10.77 a	4.83 a	6.53 a	8.33 a	12.36 a	6.57 a	8.99 a	13.53 a	8.96 a
	24	2.84 a	4.18 a	5.52 a	7.09 a	10.66 a	4.7 a	6.4 a	8.2 a	12.26 a	6.44 a	8.86 a	13.41 a	8.83 a
9	12	2.8 a	4.01 a	5.24 a	6.66 a	9.84 a	4.56 a	6.08 a	7.72 a	11.33 a	6.24 a	8.51 a	12.52 a	8.53 a
	16	2.73 a	3.94 a	5.17 a	6.6 a	9.78 a	4.49 a	6 a	7.64 a	11.27 a	6.16 a	8.43 a	12.45 a	8.45 a
	24	2.58 a	3.79 a	5.03 a	6.46 a	9.65 a	4.33 a	5.84 a	7.5 a	11.14 a	6.01 a	8.27 a	12.31 a	8.3 a
10	12	2.56 a	3.64 a	4.74 a	6.03 a	8.82 a	4.21 a	5.52 a	7.01 a	10.21 a	5.79 a	7.95 a	11.41 a	8.06 a
	16	2.48 a	3.56 a	4.66 a	5.96 a	8.75 a	4.12 a	5.43 a	6.93 a	10.14 a	5.7 a	7.86 a	11.33 a	7.97 a
	24	2.31 a	3.4 a	4.51 a	5.81 a	8.61 a	3.94 a	5.25 a	6.76 a	10 a	5.52 a	7.68 a	11.17 a	7.79 a
12	12	2.07 a	2.9 a	3.74 a	4.77 a	6.88 a	3.4 a	4.38 a	5.58 a	8.04 a	4.97 a	6.36 a	9.14 a	6.87 a
	16	1.96 a	2.8 a	3.65 a	4.68 a	6.8 a	3.29 a	4.28 a	5.48 a	7.95 a	4.86 a	6.26 a	9.04 a	6.75 a
	24	1.76 c	2.61 a	3.47 a	4.5 a	6.65 a	3.08 a	4.07 a	5.29 a	7.79 a	4.63 a	6.05 a	8.86 a	6.53 a
14	12	1.6 a	2.27 a	2.93 a	3.75 a	5.41 a	2.68 a	3.44 a	4.4 a	6.36 a	3.94 a	5.05 a	7.26 a	5.67 a
	16	1.49 c	2.17 b	2.83 a	3.65 a	5.33 a	2.56 a	3.33 a	4.3 a	6.27 a	3.82 a	4.93 a	7.16 a	5.54 a
	24	1.26 d	1.95 d	2.63 c	3.46 b	5.16 a	2.32 c	3.1 b	4.09 a	6.1 a	3.57 a	4.7 a	6.96 a	5.29 a
16	12	1.24 c	1.77 b	2.31 a	2.97 a	4.31 a	2.1 a	2.72 a	3.51 a	5.09 a	3.13 a	4.03 a	5.83 a	4.55 a
	16	1.11 d	1.66 d	2.21 c	2.87 b	4.22 a	1.97 c	2.6 b	3.39 a	5 a	3 a	3.91 a	5.72 a	4.41 a
	24	0.87 e	1.43 e	1.99 d	2.67 d	4.04 b	1.72 d	2.36 d	3.17 c	4.81 a	2.73 c	3.66 b	5.51 a	4.14 b

Wall Height (ft)	Spacing (in) o.c.	362SG200-(mils)				
		33	43	54	68	97
8	12	3.13 a	4.54 a	5.95 a	7.66 a	11.44 a
	16	3.07 a	4.48 a	5.89 a	7.6 a	11.38 a
	24	2.95 a	4.35 a	5.77 a	7.49 a	11.28 a
9	12	2.92 a	4.2 a	5.51 a	7.07 a	10.48 a
	16	2.84 a	4.13 a	5.44 a	7.01 a	10.41 a
	24	2.7 a	3.99 a	5.3 a	6.87 a	10.29 a
10	12	2.69 a	3.85 a	5.05 a	6.46 a	9.47 a
	16	2.6 a	3.76 a	4.97 a	6.38 a	9.4 a
	24	2.43 a	3.6 a	4.81 a	6.22 a	9.26 a
12	12	2.2 a	3.1 a	4.06 a	5.17 a	7.46 a
	16	2.09 a	3 a	3.96 a	5.08 a	7.38 a
	24	1.89 b	2.8 a	3.77 a	4.9 a	7.22 a
14	12	1.72 a	2.46 a	3.19 a	4.08 a	5.89 a
	16	1.61 c	2.35 a	3.09 a	3.98 a	5.8 a
	24	1.37 d	2.12 c	2.88 b	3.78 a	5.62 a
16	12	1.34 c	1.94 b	2.52 a	3.24 a	4.7 a
	16	1.21 d	1.82 c	2.41 b	3.14 a	4.6 a
	24	0.96 e	1.58 e	2.19 d	2.93 c	4.42 b

a = Deflection Exceeds L/720
b = Deflection Exceeds L/600

c = Deflection Exceeds L/480
d = Deflection Exceeds L/360

e = Deflection Exceeds L/240
f = Deflection Exceeds L/120

If not noted, deflection is less than L/720

Load Bearing Wall Members

Combined Axial & Lateral Load Tables

Refer to Important Table Notes on Page 9

5 psf Lateral Load: Axial Compression Load (kips)														
Wall Height (ft)	Spacing (in) o.c.	362SG250-(mils)				362SG300-(mils)			362SG350-(mils)	400SG200-(mils)				
		43	54	68	97	54	68	97	68	33	43	54	68	97
8	12	5.07 a	6.88 a	8.84 a	13.11 a	6.86 a	9.47 a	14.29 a	9.42 a	3.4 a	5.01 a	6.58 a	8.67 a	12.68 a
	16	5.01 a	6.81 a	8.78 a	13.06 a	6.8 a	9.4 a	14.23 a	9.36 a	3.35 a	4.95 a	6.52 a	8.62 a	12.62 a
	24	4.88 a	6.68 a	8.65 a	12.95 a	6.67 a	9.27 a	14.11 a	9.23 a	3.23 a	4.83 a	6.41 a	8.5 a	12.51 a
9	12	4.75 a	6.39 a	8.18 a	12.05 a	6.49 a	8.91 a	13.25 a	8.89 a	3.22 a	4.71 a	6.21 a	8.18 a	11.9 a
	16	4.67 a	6.31 a	8.11 a	11.98 a	6.41 a	8.83 a	13.18 a	8.82 a	3.14 a	4.64 a	6.14 a	8.11 a	11.83 a
	24	4.52 a	6.15 a	7.96 a	11.86 a	6.25 a	8.68 a	13.03 a	8.67 a	3 a	4.49 a	6 a	7.97 a	11.69 a
10	12	4.41 a	5.86 a	7.48 a	10.94 a	6.08 a	8.35 a	12.15 a	8.42 a	3.01 a	4.39 a	5.79 a	7.64 a	11.05 a
	16	4.32 a	5.77 a	7.4 a	10.86 a	5.99 a	8.26 a	12.07 a	8.33 a	2.93 a	4.3 a	5.71 a	7.56 a	10.96 a
	24	4.14 a	5.59 a	7.23 a	10.72 a	5.81 a	8.08 a	11.91 a	8.15 a	2.76 a	4.14 a	5.55 a	7.4 a	10.8 a
12	12	3.64 a	4.74 a	6.04 a	8.7 a	5.29 a	6.88 a	9.88 a	7.33 a	2.56 a	3.69 a	4.9 a	6.43 a	9.23 a
	16	3.53 a	4.64 a	5.94 a	8.61 a	5.17 a	6.77 a	9.78 a	7.22 a	2.45 a	3.59 a	4.8 a	6.33 a	9.13 a
	24	3.31 a	4.42 a	5.74 a	8.45 a	4.94 a	6.56 a	9.59 a	6.99 a	2.24 a	3.38 a	4.6 a	6.14 a	8.93 a
14	12	2.89 a	3.74 a	4.78 a	6.9 a	4.28 a	5.47 a	7.87 a	6.14 a	2.09 a	2.99 a	3.98 a	5.17 a	7.4 a
	16	2.77 a	3.62 a	4.67 a	6.81 a	4.15 a	5.35 a	7.76 a	6.01 a	1.97 a	2.87 a	3.87 a	5.06 a	7.29 a
	24	2.52 c	3.39 a	4.45 a	6.63 a	3.89 a	5.11 a	7.55 a	5.74 a	1.72 c	2.63 b	3.64 a	4.84 a	7.07 a
16	12	2.29 a	2.97 a	3.82 a	5.53 a	3.41 a	4.38 a	6.33 a	4.93 a	1.65 b	2.4 a	3.22 a	4.14 a	5.93 a
	16	2.16 c	2.84 a	3.7 a	5.44 a	3.27 a	4.25 a	6.22 a	4.79 a	1.51 c	2.27 b	3.1 a	4.02 a	5.81 a
	24	1.9 d	2.59 c	3.46 b	5.25 a	2.99 c	3.99 b	5.99 a	4.51 a	1.24 e	2.01 d	2.85 c	3.79 b	5.58 a

Wall Height (ft)	Spacing (in) o.c.	400SG250-(mils)				400SG300-(mils)		
		43	54	68	97	54	68	97
8	12	5.51 a	7.42 a	9.99 a	14.55 a	7.44 a	10.45 a	16.32 a
	16	5.44 a	7.35 a	9.93 a	14.49 a	7.38 a	10.39 a	16.26 a
	24	5.32 a	7.23 a	9.8 a	14.37 a	7.26 a	10.26 a	16.14 a
9	12	5.24 a	7.11 a	9.42 a	13.66 a	7.12 a	10.02 a	15.35 a
	16	5.17 a	7.04 a	9.34 a	13.59 a	7.04 a	9.94 a	15.27 a
	24	5.02 a	6.88 a	9.19 a	13.45 a	6.89 a	9.78 a	15.13 a
10	12	4.94 a	6.71 a	8.8 a	12.71 a	6.76 a	9.49 a	14.3 a
	16	4.85 a	6.62 a	8.71 a	12.63 a	6.67 a	9.4 a	14.22 a
	24	4.67 a	6.44 a	8.54 a	12.47 a	6.49 a	9.22 a	14.05 a
12	12	4.26 a	5.69 a	7.45 a	10.69 a	5.97 a	8.41 a	12.1 a
	16	4.15 a	5.58 a	7.34 a	10.59 a	5.85 a	8.29 a	12 a
	24	3.93 a	5.35 a	7.13 a	10.4 a	5.62 a	8.05 a	11.79 a
14	12	3.51 a	4.65 a	6.02 a	8.65 a	5.22 a	6.87 a	9.86 a
	16	3.38 a	4.52 a	5.9 a	8.54 a	5.08 a	6.73 a	9.74 a
	24	3.12 a	4.26 a	5.66 a	8.32 a	4.8 a	6.47 a	9.51 a
16	12	2.82 a	3.76 a	4.84 a	6.97 a	4.29 a	5.53 a	7.97 a
	16	2.68 a	3.62 a	4.7 a	6.85 a	4.14 a	5.38 a	7.85 a
	24	2.4 c	3.34 b	4.44 a	6.62 a	3.83 b	5.1 a	7.6 a

a = Deflection Exceeds L/720
b = Deflection Exceeds L/600

c = Deflection Exceeds L/480
d = Deflection Exceeds L/360

e = Deflection Exceeds L/240
f = Deflection Exceeds L/120

If not noted, deflection is less than L/720

Load Bearing Wall Members

Combined Axial & Lateral Load Tables

Refer to Important Table Notes on Page 9

5 Psf Lateral Load: Axial Compression Load (kips)													
Wall Height (ft)	Spacing (in) o.c.	400SG350-(mils)			550SG162-(mils)				550SG200-(mils)				
		68	97	118	33	43	54	68	33	43	54	68	97
8	12	10.42 a	17.06 a	21.98 a	4.34 a	5.73 a	7.29 a	9.06 a	6.15 a	8.63 a	10.92 a	14.29 a	20.26 a
	16	10.35 a	17 a	21.92 a	4.28 a	5.67 a	7.24 a	9.01 a	6.08 a	8.56 a	10.85 a	14.24 a	20.21 a
	24	10.23 a	16.87 a	21.8 a	4.15 a	5.56 a	7.13 a	8.92 a	5.94 a	8.42 a	10.73 a	14.12 a	20.11 a
9	12	9.97 a	16.22 a	20.69 a	4.29 a	5.69 a	7.24 a	9.02 a	6.1 a	8.57 a	10.87 a	14.25 a	20.22 a
	16	9.9 a	16.15 a	20.62 a	4.21 a	5.61 a	7.18 a	8.97 a	6.01 a	8.49 a	10.79 a	14.18 a	20.16 a
	24	9.74 a	15.99 a	20.47 a	4.05 a	5.47 a	7.05 a	8.85 a	5.83 a	8.31 a	10.63 a	14.03 a	20.03 a
10	12	9.48 a	15.35 a	19.3 a	4.23 a	5.63 a	7.2 a	8.98 a	6.03 a	8.51 a	10.81 a	14.2 a	20.18 a
	16	9.39 a	15.26 a	19.22 a	4.13 a	5.54 a	7.12 a	8.91 a	5.92 a	8.4 a	10.71 a	14.11 a	20.1 a
	24	9.21 a	15.08 a	19.05 a	3.93 a	5.36 a	6.96 a	8.77 a	5.7 a	8.19 a	10.52 a	13.93 a	19.94 a
12	12	8.52 a	13.46 a	16.38 a	4.1 a	5.51 a	7.1 a	8.89 a	5.89 a	8.37 a	10.68 a	14.08 a	20.07 a
	16	8.4 a	13.35 a	16.28 a	3.96 a	5.38 a	6.98 a	8.79 a	5.73 a	8.22 a	10.54 a	13.96 a	19.96 a
	24	8.17 a	13.12 a	16.08 a	3.67 a	5.12 a	6.75 a	8.58 a	5.41 a	7.91 a	10.26 a	13.7 a	19.73 a
14	12	7.36 a	11.03 a	13.42 a	3.94 a	5.37 a	6.97 a	8.78 a	5.39 a	7.59 a	9.69 a	12.8 a	18.42 a
	16	7.22 a	10.9 a	13.3 a	3.75 a	5.19 a	6.82 a	8.64 a	5.19 a	7.4 a	9.51 a	12.64 a	18.28 a
	24	6.94 a	10.65 a	13.07 a	3.35 a	4.84 a	6.51 a	8.36 a	4.78 a	7.01 a	9.16 a	12.32 a	18 a
16	12	6.2 a	8.94 a	10.88 a	3.76 a	5.19 a	6.83 a	8.65 a	4.6 a	6.49 a	8.3 a	10.89 a	15.64 a
	16	6.05 a	8.8 a	10.76 a	3.51 a	4.96 a	6.63 a	8.47 a	4.37 a	6.27 a	8.1 a	10.71 a	15.48 a
	24	5.73 a	8.53 a	10.51 a	2.99 c	4.5 a	6.22 a	8.11 a	3.9 a	5.83 a	7.7 a	10.35 a	15.16 a

Wall Height (ft)	Spacing (in) o.c.	550SG250-(mils)				550SG300-(mils)				
		43	54	68	97	43	54	68	97	118
8	12	9.41	12.73	16.92	26.47	9.39 a	13.2 a	17.24 a	26.87 a	36.8 a
	16	9.34	12.66	16.85	26.41	9.33 a	13.13 a	17.17 a	26.8 a	36.74 a
	24	9.19	12.52	16.72	26.28	9.19 a	12.99 a	17.04 a	26.68 a	36.61 a
9	12	9.35	12.67	16.87	26.42	9.34 a	12.84 a	16.78 a	26.17 a	35.55 a
	16	9.26	12.58	16.78	26.34	9.25 a	12.76 a	16.7 a	26.09 a	35.48 a
	24	9.08	12.41	16.61	26.18	9.08 a	12.59 a	16.53 a	25.93 a	35.32 a
10	12	9.29	12.27	16.41	25.70	9.28 a	12.43 a	16.25 a	25.36 a	34.1 a
	16	9.18	12.17	16.31	25.61	9.17 a	12.33 a	16.15 a	25.27 a	34 a
	24	8.96	11.95	16.10	25.42	8.96 a	12.12 a	15.95 a	25.08 a	33.82 a
12	12	8.87	11.28	15.21	23.15	8.87 a	11.46 a	15.03 a	23.56 a	30.76 a
	16	8.72	11.13	15.07	23.03	8.72 a	11.33 a	14.89 a	23.44 a	30.64 a
	24	8.41	10.85	14.79	22.79	8.42 a	11.05 a	14.63 a	23.18 a	30.4 a
14	12	7.96	10.24	13.58	20.32	8 a	10.38 a	13.8 a	21.2 a	27.09 a
	16	7.77	10.07	13.41	20.17	7.81 a	10.2 a	13.63 a	21.05 a	26.95 a
	24	7.38	9.71	13.07	19.88	7.44 a	9.86 a	13.3 a	20.73 a	26.66 a
16	12	6.99	9.19	11.77	17.42	7.09 a	9.22 a	12.4 a	18.52 a	23.33 a
	16	6.76	8.98	11.57	17.25	6.86 a	9.02 a	12.21 a	18.34 a	23.17 a
	24	6.31	8.55	11.18	16.92	6.42 a	8.61 a	11.81 a	17.98 a	22.84 a

a = Deflection Exceeds L/720
b = Deflection Exceeds L/600

c = Deflection Exceeds L/480
d = Deflection Exceeds L/360

e = Deflection Exceeds L/240
f = Deflection Exceeds L/120

If not noted, deflection is less than L/720

Load Bearing Wall Members

Combined Axial & Lateral Load Tables

Refer to Important Table Notes on Page 9

5 Psf Lateral Load: Axial Compression Load (kips)														
Wall Height (ft)	Spacing (in) o.c.	600SG162-(mils)				600SG200-(mils)					600SG250-(mils)			
		33	43	54	68	33	43	54	68	97	43	54	68	97
8	12	4.18 a	6.2 a	7.89 a	9.82 a	6.06 a	9.14 a	11.59 a	15.17 a	21.53 a	9.36 a	13.26 a	17.78 a	27.76 a
	16	4.12 a	6.15 a	7.84 a	9.78 a	6 a	9.08 a	11.53 a	15.12 a	21.49 a	9.29 a	13.19 a	17.71 a	27.7 a
	24	4.01 a	6.03 a	7.74 a	9.69 a	5.87 a	8.95 a	11.41 a	15.01 a	21.39 a	9.17 a	13.06 a	17.58 a	27.59 a
9	12	4.13 a	6.16 a	7.85 a	9.79 a	6.01 a	9.09 a	11.55 a	15.13 a	21.49 a	9.31 a	13.21 a	17.73 a	27.71 a
	16	4.06 a	6.08 a	7.79 a	9.73 a	5.93 a	9.01 a	11.47 a	15.06 a	21.43 a	9.23 a	13.12 a	17.65 a	27.64 a
	24	3.92 a	5.94 a	7.66 a	9.62 a	5.77 a	8.84 a	11.31 a	14.92 a	21.31 a	9.06 a	12.96 a	17.48 a	27.49 a
10	12	4.08 a	6.11 a	7.8 a	9.75 a	5.96 a	9.03 a	11.49 a	15.08 a	21.45 a	9.25 a	13.15 a	17.65 a	27.66 a
	16	3.99 a	6.02 a	7.73 a	9.68 a	5.86 a	8.93 a	11.4 a	15 a	21.38 a	9.15 a	13.05 a	17.55 a	27.57 a
	24	3.81 a	5.83 a	7.57 a	9.54 a	5.66 a	8.72 a	11.21 a	14.83 a	21.23 a	8.95 a	12.84 a	17.34 a	27.39 a
12	12	3.96 a	5.99 a	7.7 a	9.65 a	5.82 a	8.9 a	11.37 a	14.97 a	21.35 a	9.12 a	12.34 a	16.52 a	25.52 a
	16	3.84 a	5.86 a	7.59 a	9.55 a	5.68 a	8.75 a	11.23 a	14.85 a	21.25 a	8.97 a	12.2 a	16.39 a	25.4 a
	24	3.58 a	5.6 a	7.36 a	9.35 a	5.4 a	8.45 a	10.95 a	14.6 a	21.03 a	8.68 a	11.91 a	16.11 a	25.15 a
14	12	3.83 a	5.85 a	7.58 a	9.54 a	5.67 a	8.5 a	10.9 a	14.45 a	20.85 a	8.84 a	11.27 a	15.21 a	22.87 a
	16	3.65 a	5.67 a	7.43 a	9.41 a	5.48 a	8.31 a	10.72 a	14.28 a	20.7 a	8.65 a	11.09 a	15.04 a	22.72 a
	24	3.3 a	5.31 a	7.12 a	9.13 a	5.09 a	7.92 a	10.36 a	13.96 a	20.41 a	8.26 a	10.73 a	14.69 a	22.42 a
16	12	3.67 a	5.68 a	7.44 a	9.42 a	5.29 a	7.48 a	9.56 a	12.6 a	18.15 a	7.91 a	10.3 a	13.46 a	20.07 a
	16	3.44 a	5.45 a	7.24 a	9.24 a	5.05 a	7.25 a	9.35 a	12.41 a	17.99 a	7.68 a	10.08 a	13.26 a	19.9 a
	24	2.98 b	4.99 a	6.84 a	8.88 a	4.56 a	6.79 a	8.93 a	12.04 a	17.65 a	7.22 a	9.65 a	12.85 a	19.55 a

Wall Height (ft)	Spacing (in) o.c.	600SG300-(mils)				
		43	54	68	97	118
8	12	9.38 a	13.34 a	18.4 a	28.58 a	38.97 a
	16	9.32 a	13.28 a	18.34 a	28.52 a	38.91 a
	24	9.2 a	13.15 a	18.21 a	28.4 a	38.79 a
9	12	9.33 a	13.29 a	18 a	27.96 a	38.16 a
	16	9.25 a	13.21 a	17.92 a	27.89 a	38.08 a
	24	9.1 a	13.05 a	17.76 a	27.73 a	37.93 a
10	12	9.28 a	13.23 a	17.52 a	27.24 a	36.87 a
	16	9.18 a	13.13 a	17.43 a	27.14 a	36.78 a
	24	8.98 a	12.93 a	17.23 a	26.96 a	36.61 a
12	12	9.15 a	12.53 a	16.38 a	25.54 a	33.85 a
	16	9.01 a	12.39 a	16.25 a	25.42 a	33.73 a
	24	8.73 a	12.12 a	15.99 a	25.17 a	33.49 a
14	12	8.88 a	11.5 a	15.15 a	23.66 a	30.42 a
	16	8.69 a	11.33 a	14.98 a	23.5 a	30.27 a
	24	8.31 a	10.98 a	14.65 a	23.18 a	29.98 a
16	12	7.99 a	10.39 a	13.89 a	21.09 a	26.81 a
	16	7.76 a	10.18 a	13.69 a	20.9 a	26.64 a
	24	7.31 a	9.76 a	13.29 a	20.53 a	26.31 a

a = Deflection Exceeds L/720
b = Deflection Exceeds L/600

c = Deflection Exceeds L/480
d = Deflection Exceeds L/360

e = Deflection Exceeds L/240
f = Deflection Exceeds L/120

If not noted, deflection is less than L/720

Load Bearing Wall Members

Combined Axial & Lateral Load Tables

Refer to Important Table Notes on Page 9

5 Psf Lateral Load: Axial Compression Load (kips)														
Wall Height (ft)	Spacing (in) o.c.	800SG162-(mils)				800SG200-(mils)					800SG250-(mils)			
		33	43	54	68	33	43	54	68	97	43	54	68	97
8	12	3.45 a	5.28 a	7.59 a	10.96 a	5.47 a	8.33 a	11.91 a	17.06 a	26.05 a	8.84 a	12.63 a	18.1 a	31.14 a
	16	3.41 a	5.25 a	7.55 a	10.92 a	5.43 a	8.29 a	11.86 a	17.01 a	26 a	8.79 a	12.59 a	18.05 a	31.09 a
	24	3.34 a	5.17 a	7.47 a	10.85 a	5.34 a	8.2 a	11.77 a	16.92 a	25.92 a	8.7 a	12.49 a	17.95 a	31 a
9	12	3.42 a	5.25 a	7.56 a	10.93 a	5.44 a	8.3 a	11.87 a	17.02 a	26.01 a	8.8 a	12.6 a	18.06 a	31.1 a
	16	3.38 a	5.21 a	7.51 a	10.88 a	5.38 a	8.24 a	11.81 a	16.96 a	25.96 a	8.74 a	12.54 a	18 a	31.04 a
	24	3.29 a	5.11 a	7.41 a	10.79 a	5.27 a	8.13 a	11.7 a	16.85 a	25.86 a	8.63 a	12.42 a	17.88 a	30.92 a
10	12	3.39 a	5.22 a	7.52 a	10.9 a	5.4 a	8.26 a	11.83 a	16.98 a	25.98 a	8.76 a	12.55 a	18.02 a	31.06 a
	16	3.33 a	5.16 a	7.46 a	10.84 a	5.33 a	8.19 a	11.76 a	16.91 a	25.91 a	8.69 a	12.48 a	17.94 a	30.98 a
	24	3.22 a	5.05 a	7.34 a	10.72 a	5.2 a	8.05 a	11.62 a	16.77 a	25.78 a	8.55 a	12.34 a	17.79 a	30.84 a
12	12	3.32 a	5.14 a	7.45 a	10.82 a	5.31 a	8.17 a	11.74 a	16.89 a	25.89 a	8.67 a	12.46 a	17.92 a	30.96 a
	16	3.24 a	5.06 a	7.36 a	10.74 a	5.22 a	8.07 a	11.63 a	16.79 a	25.8 a	8.57 a	12.36 a	17.81 a	30.85 a
	24	3.07 a	4.89 a	7.19 a	10.57 a	5.02 a	7.87 a	11.43 a	16.59 a	25.61 a	8.37 a	12.15 a	17.59 a	30.64 a
14	12	3.23 a	5.05 a	7.35 a	10.73 a	5.21 a	8.06 a	11.62 a	16.78 a	25.79 a	8.56 a	12.35 a	17.8 a	30.85 a
	16	3.12 a	4.94 a	7.23 a	10.62 a	5.08 a	7.92 a	11.48 a	16.64 a	25.66 a	8.42 a	12.2 a	17.65 a	30.7 a
	24	2.9 a	4.71 a	7 a	10.39 a	4.82 a	7.65 a	11.2 a	16.37 a	25.41 a	8.15 a	11.92 a	17.36 a	30.41 a
16	12	3.13 a	4.95 a	7.24 a	10.63 a	5.09 a	7.93 a	11.49 a	16.66 a	25.67 a	8.43 a	12.22 a	17.67 a	29.52 a
	16	2.98 a	4.8 a	7.09 a	10.48 a	4.92 a	7.76 a	11.31 a	16.48 a	25.51 a	8.25 a	12.03 a	17.47 a	29.34 a
	24	2.7 a	4.5 a	6.78 a	10.18 a	4.58 a	7.4 a	10.94 a	16.12 a	25.18 a	7.9 a	11.66 a	17.09 a	28.98 a

Wall Height (ft)	Spacing (in) o.c.	800SG300-(mils)				
		43	54	68	97	118
8	12	9.08 a	12.99 a	18.65 a	32.2 a	43.35 a
	16	9.03 a	12.95 a	18.6 a	32.15 a	43.3 a
	24	8.94 a	12.85 a	18.5 a	32.05 a	43.21 a
9	12	9.04 a	12.95 a	18.61 a	32.16 a	43.31 a
	16	8.98 a	12.9 a	18.55 a	32.1 a	43.25 a
	24	8.87 a	12.78 a	18.43 a	31.97 a	43.13 a
10	12	9 a	12.91 a	18.56 a	32.11 a	43.27 a
	16	8.93 a	12.84 a	18.49 a	32.04 a	43.2 a
	24	8.79 a	12.7 a	18.34 a	31.88 a	43.05 a
12	12	8.91 a	12.82 a	18.47 a	32.01 a	43.17 a
	16	8.81 a	12.71 a	18.36 a	31.9 a	43.07 a
	24	8.61 a	12.51 a	18.15 a	31.67 a	42.85 a
14	12	8.8 a	12.71 a	18.35 a	31.36 a	41.92 a
	16	8.66 a	12.56 a	18.2 a	31.21 a	41.77 a
	24	8.39 a	12.28 a	17.91 a	30.9 a	41.49 a
16	12	8.67 a	12.58 a	18.22 a	29.64 a	39.02 a
	16	8.49 a	12.39 a	18.03 a	29.45 a	38.85 a
	24	8.14 a	12.02 a	17.64 a	29.07 a	38.5 a

a = Deflection Exceeds L/720
b = Deflection Exceeds L/600

c = Deflection Exceeds L/480
d = Deflection Exceeds L/360

e = Deflection Exceeds L/240
f = Deflection Exceeds L/120

If not noted, deflection is less than L/720

Load Bearing Wall Members

Combined Axial & Lateral Load Tables

Refer to Important Table Notes on Page 9

15 Psf Lateral Load: Axial Compression Load (kips)													
Wall Height (ft)	Spacing (in) o.c.	350SG200-(mils)					350SG250-(mils)				350SG300-(mils)		
		33	43	54	68	97	43	54	68	97	54	68	97
8	12	2.66 a	3.99 a	5.34 a	6.92 a	10.5 a	4.51 a	6.2 a	8.01 a	12.09 a	6.25 a	8.67 a	13.23 a
	16	2.47 a	3.81 a	5.16 a	6.74 a	10.34 a	4.31 a	6 a	7.83 a	11.93 a	6.05 a	8.47 a	13.05 a
	24	2.1 a	3.44 a	4.81 a	6.4 a	10.02 a	3.92 a	5.6 a	7.45 a	11.6 a	5.66 a	8.08 a	12.69 a
9	12	2.36 a	3.58 a	4.82 a	6.26 a	9.47 a	4.1 a	5.61 a	7.27 a	10.96 a	5.77 a	8.04 a	12.1 a
	16	2.14 a	3.36 a	4.61 a	6.06 a	9.28 a	3.86 a	5.37 a	7.05 a	10.77 a	5.54 a	7.81 a	11.89 a
	24	1.7 b	2.93 a	4.19 a	5.65 a	8.91 a	3.4 a	4.9 a	6.61 a	10.39 a	5.07 a	7.34 a	11.46 a
10	12	2.06 a	3.15 a	4.27 a	5.58 a	8.4 a	3.67 a	4.99 a	6.51 a	9.79 a	5.25 a	7.4 a	10.93 a
	16	1.8 b	2.9 a	4.04 a	5.35 a	8.2 a	3.4 a	4.72 a	6.26 a	9.58 a	4.98 a	7.13 a	10.69 a
	24	1.3 d	2.41 b	3.56 a	4.9 a	7.79 a	2.87 b	4.19 a	5.76 a	9.15 a	4.44 a	6.59 a	10.21 a
12	12	1.45 c	2.32 b	3.19 a	4.24 a	6.41 a	2.76 a	3.76 a	5 a	7.55 a	4.29 a	5.73 a	8.58 a
	16	1.14 d	2.02 c	2.92 b	3.98 a	6.18 a	2.44 b	3.45 a	4.71 a	7.31 a	3.95 a	5.41 a	8.3 a
	24	0.53 e	1.44 e	2.37 d	3.45 c	5.71 a	1.79 d	2.83 c	4.12 b	6.83 a	3.27 c	4.77 b	7.74 a
14	12	0.92 e	1.63 d	2.33 c	3.17 b	4.91 a	1.97 c	2.76 b	3.77 a	5.83 a	3.19 a	4.35 a	6.65 a
	16	0.57 e	1.3 e	2.03 d	2.89 c	4.65 b	1.61 d	2.42 d	3.45 c	5.57 a	2.81 c	4 b	6.35 a
	24		0.66 f	1.43 e	2.31 e	4.14 d	0.89 e	1.74 e	2.81 d	5.04 c	2.05 d	3.3 d	5.74 b
16	12	0.5 f	1.08 e	1.67 d	2.36 d	3.77 b	1.34 e	2 d	2.83 c	4.53 a	2.32 c	3.29 b	5.18 a
	16	0.13 f	0.74 f	1.35 e	2.06 e	3.51 d	0.96 e	1.63 e	2.49 d	4.26 c	1.92 d	2.91 d	4.86 b
	24		0.05 f	0.72 f	1.45 f	2.97 e	0.2 f	0.91 f	1.81 e	3.7 d	1.11 e	2.17 e	4.21 d

Wall Height (ft)	Spacing (in) o.c.	350SG350-(mils)		362SG200-(mils)			
		68	33	43	54	68	97
8	12	8.64 a	2.76 a	4.17 a	5.59 a	7.31 a	11.11 a
	16	8.45 a	2.58 a	3.99 a	5.41 a	7.14 a	10.95 a
	24	8.07 a	2.21 a	3.62 a	5.05 a	6.79 a	10.63 a
9	12	8.07 a	2.48 a	3.77 a	5.09 a	6.67 a	10.1 a
	16	7.84 a	2.26 a	3.55 a	4.88 a	6.46 a	9.91 a
	24	7.38 a	1.82 b	3.11 a	4.46 a	6.05 a	9.54 a
10	12	7.52 a	2.18 a	3.35 a	4.57 a	5.99 a	9.05 a
	16	7.25 a	1.92 a	3.1 a	4.33 a	5.76 a	8.84 a
	24	6.71 a	1.42 c	2.6 b	3.85 a	5.3 a	8.41 a
12	12	6.19 a	1.57 c	2.51 a	3.49 a	4.63 a	6.98 a
	16	5.86 a	1.26 d	2.21 c	3.21 b	4.36 a	6.74 a
	24	5.19 a	0.63 e	1.61 d	2.64 d	3.81 c	6.26 a
14	12	4.9 a	1.02 d	1.79 c	2.57 c	3.49 a	5.36 a
	16	4.52 a	0.67 e	1.46 d	2.26 d	3.19 c	5.1 a
	24	3.75 c		0.79 e	1.63 e	2.59 d	4.58 c
16	12	3.73 b	0.58 e	1.22 e	1.86 d	2.61 c	4.14 b
	16	3.32 c	0.2 f	0.86 e	1.53 e	2.3 d	3.87 c
	24	2.49 e		0.15 f	0.86 f	1.67 e	3.31 e

a = Deflection Exceeds L/720
b = Deflection Exceeds L/600

c = Deflection Exceeds L/480
d = Deflection Exceeds L/360

e = Deflection Exceeds L/240
f = Deflection Exceeds L/120

If not noted, deflection is less than L/720

Load Bearing Wall Members

Combined Axial & Lateral Load Tables

Refer to Important Table Notes on Page 9

15 Psf Lateral Load: Axial Compression Load (kips)														
Wall Height (ft)	Spacing (in) o.c.	362SG250-(mils)				362SG300-(mils)			362SG350-(mils)	400SG200-(mils)				
		43	54	68	97	54	68	97	68	33	43	54	68	97
8	12	4.68 a	6.48 a	8.46 a	12.78 a	6.48 a	9.07 a	13.93 a	9.04 a	3.05 a	4.65 a	6.23 a	8.33 a	12.33 a
	16	4.49 a	6.28 a	8.27 a	12.62 a	6.28 a	8.88 a	13.75 a	8.85 a	2.87 a	4.47 a	6.06 a	8.16 a	12.15 a
	24	4.1 a	5.88 a	7.89 a	12.29 a	5.9 a	8.49 a	13.39 a	8.47 a	2.52 a	4.11 a	5.71 a	7.81 a	11.79 a
9	12	4.29 a	5.91 a	7.73 a	11.66 a	6.02 a	8.44 a	12.82 a	8.44 a	2.79 a	4.28 a	5.79 a	7.77 a	11.47 a
	16	4.06 a	5.68 a	7.51 a	11.47 a	5.79 a	8.21 a	12.61 a	8.21 a	2.57 a	4.06 a	5.58 a	7.56 a	11.26 a
	24	3.59 a	5.21 a	7.06 a	11.09 a	5.32 a	7.74 a	12.18 a	7.75 a	2.14 a	3.63 a	5.16 a	7.15 a	10.84 a
10	12	3.87 a	5.32 a	6.97 a	10.51 a	5.54 a	7.81 a	11.66 a	7.88 a	2.51 a	3.88 a	5.3 a	7.16 a	10.56 a
	16	3.6 a	5.05 a	6.72 a	10.29 a	5.27 a	7.53 a	11.42 a	7.61 a	2.25 a	3.63 a	5.06 a	6.92 a	10.31 a
	24	3.06 a	4.51 a	6.21 a	9.86 a	4.72 a	6.99 a	10.93 a	7.07 a	1.75 b	3.13 a	4.57 a	6.44 a	9.82 a
12	12	2.98 a	4.1 a	5.44 a	8.2 a	4.59 a	6.23 a	9.3 a	6.65 a	1.92 a	3.07 a	4.29 a	5.84 a	8.63 a
	16	2.66 b	3.78 a	5.14 a	7.95 a	4.25 a	5.9 a	9.02 a	6.3 a	1.6 c	2.75 b	3.99 a	5.55 a	8.34 a
	24	2 d	3.14 c	4.54 b	7.45 a	3.55 b	5.24 a	8.44 a	5.62 a	0.96 d	2.13 d	3.39 c	4.96 a	7.74 a
14	12	2.15 c	3.03 b	4.12 a	6.36 a	3.5 a	4.75 a	7.24 a	5.35 a	1.35 d	2.28 b	3.3 a	4.51 a	6.74 a
	16	1.79 d	2.68 c	3.79 b	6.09 a	3.1 c	4.38 a	6.92 a	4.95 a	0.97 e	1.92 d	2.96 c	4.18 b	6.42 a
	24	1.05 e	1.97 e	3.13 d	5.54 c	2.32 d	3.66 c	6.29 b	4.15 c	0.22 f	1.21 e	2.27 d	3.53 d	5.76 b
16	12	1.5 d	2.21 d	3.11 c	4.96 a	2.57 c	3.61 b	5.66 a	4.08 a	0.84 e	1.62 d	2.48 c	3.44 b	5.23 a
	16	1.1 e	1.84 e	2.76 d	4.67 c	2.15 d	3.22 c	5.33 b	3.66 c	0.43 f	1.24 e	2.11 d	3.09 d	4.89 b
	24	0.31 f	1.08 f	2.06 e	4.09 d	1.31 e	2.45 e	4.66 d	2.81 d		0.46 f	1.36 e	2.39 e	4.19 d

Wall Height (ft)	Spacing (in) o.c.	400SG250-(mils)				400SG300-(mils)		
		43	54	68	97	54	68	97
8	12	5.13 a	7.04 a	9.61 a	14.19 a	7.07 a	10.07 a	15.96 a
	16	4.95 a	6.85 a	9.42 a	14.02 a	6.89 a	9.88 a	15.77 a
	24	4.57 a	6.46 a	9.04 a	13.67 a	6.51 a	9.49 a	15.41 a
9	12	4.79 a	6.65 a	8.96 a	13.24 a	6.66 a	9.55 a	14.91 a
	16	4.56 a	6.41 a	8.74 a	13.04 a	6.44 a	9.31 a	14.69 a
	24	4.11 a	5.95 a	8.28 a	12.62 a	5.99 a	8.85 a	14.26 a
10	12	4.4 a	6.17 a	8.27 a	12.23 a	6.22 a	8.94 a	13.8 a
	16	4.14 a	5.89 a	8.01 a	11.99 a	5.96 a	8.67 a	13.55 a
	24	3.6 a	5.34 a	7.48 a	11.51 a	5.42 a	8.12 a	13.05 a
12	12	3.59 a	5.01 a	6.8 a	10.1 a	5.27 a	7.7 a	11.48 a
	16	3.25 a	4.67 a	6.47 a	9.81 a	4.93 a	7.34 a	11.17 a
	24	2.57 c	3.99 b	5.82 a	9.22 a	4.24 a	6.63 a	10.56 a
14	12	2.73 b	3.88 a	5.29 a	8 a	4.38 a	6.07 a	9.17 a
	16	2.34 c	3.49 b	4.93 a	7.67 a	3.96 a	5.66 a	8.82 a
	24	1.55 e	2.72 d	4.19 c	7.02 a	3.12 c	4.86 b	8.13 a
16	12	1.97 d	2.92 c	4.05 a	6.27 a	3.36 b	4.67 a	7.23 a
	16	1.54 e	2.5 d	3.66 c	5.92 a	2.9 c	4.24 b	6.86 a
	24	0.69 f	1.66 e	2.88 d	5.23 c	1.97 e	3.38 d	6.13 c

a = Deflection Exceeds L/720
b = Deflection Exceeds L/600

c = Deflection Exceeds L/480
d = Deflection Exceeds L/360

e = Deflection Exceeds L/240
f = Deflection Exceeds L/120

If not noted, deflection is less than L/720

Load Bearing Wall Members

Combined Axial & Lateral Load Tables

Refer to Important Table Notes on Page 9

15 Psf Lateral Load: Axial Compression Load (kips)													
Wall Height (ft)	Spacing (in) o.c.	400SG350-(mils)			550SG162-(mils)				550SG200-(mils)				
		68	97	118	43	54	68	97	33	43	54	68	97
8	12	10.04 a	16.68 a	21.62 a	3.96 a	5.38 a	6.98 a	8.79 a	5.73 a	8.22 a	10.54 a	13.96 a	19.96 a
	16	9.85 a	16.5 a	21.44 a	3.76 a	5.21 a	6.83 a	8.65 a	5.52 a	8.01 a	10.35 a	13.78 a	19.81 a
	24	9.48 a	16.12 a	21.07 a	3.38 a	4.86 a	6.53 a	8.38 a	5.1 a	7.61 a	9.97 a	13.45 a	19.5 a
9	12	9.52 a	15.77 a	20.26 a	3.8 a	5.24 a	6.86 a	8.68 a	5.56 a	8.06 a	10.39 a	13.82 a	19.84 a
	16	9.29 a	15.54 a	20.04 a	3.56 a	5.02 a	6.67 a	8.51 a	5.29 a	7.8 a	10.15 a	13.61 a	19.65 a
	24	8.83 a	15.09 a	19.6 a	3.07 a	4.58 a	6.29 a	8.16 a	4.76 a	7.28 a	9.67 a	13.18 a	19.26 a
10	12	8.95 a	14.82 a	18.8 a	3.63 a	5.09 a	6.73 a	8.56 a	5.37 a	7.87 a	10.22 a	13.67 a	19.7 a
	16	8.68 a	14.55 a	18.55 a	3.33 a	4.81 a	6.49 a	8.34 a	5.04 a	7.55 a	9.92 a	13.4 a	19.47 a
	24	8.14 a	14.02 a	18.05 a	2.72 a	4.27 a	6.02 a	7.92 a	4.38 a	6.92 a	9.33 a	12.87 a	18.99 a
12	12	7.82 a	12.78 a	15.77 a	3.23 a	4.73 a	6.41 a	8.28 a	4.94 a	7.45 a	9.83 a	13.32 a	19.39 a
	16	7.47 a	12.44 a	15.46 a	2.8 a	4.33 a	6.07 a	7.97 a	4.46 a	6.99 a	9.41 a	12.94 a	19.05 a
	24	6.76 a	11.77 a	14.84 a	1.93 b	3.54 a	5.39 a	7.36 a	3.51 a	6.08 a	8.55 a	12.17 a	18.37 a
14	12	6.52 a	10.27 a	12.72 a	2.76 a	4.3 a	6.04 a	7.94 a	4.17 a	6.43 a	8.62 a	11.84 a	17.57 a
	16	6.1 a	9.89 a	12.38 a	2.17 b	3.76 a	5.58 a	7.53 a	3.56 a	5.86 a	8.09 a	11.37 a	17.14 a
	24	5.26 b	9.13 a	11.69 a	0.98 d	2.69 c	4.65 b	6.69 a	2.34 c	4.7 b	7.02 a	10.41 a	16.28 a
16	12	5.26 a	8.13 a	10.14 a	2.22 c	3.8 b	5.62 a	7.56 a	3.19 b	5.17 a	7.09 a	9.82 a	14.68 a
	16	4.79 b	7.72 a	9.77 a	1.44 d	3.1 c	5.01 b	7.02 a	2.49 c	4.51 b	6.48 a	9.28 a	14.2 a
	24	3.85 d	6.91 b	9.03 a		1.7 e	3.8 d	5.93 c	1.08 e	3.19 d	5.27 c	8.21 b	13.25 a

Wall Height (ft)	Spacing (in) o.c.	550SG250-(mils)				550SG300-(mils)				
		33	43	54	68	43	54	68	97	118
8	12	8.98 a	12.31 a	16.51 a	26.1 a	8.98 a	12.78 a	16.84 a	26.49 a	36.42 a
	16	8.77 a	12.1 a	16.31 a	25.91 a	8.78 a	12.57 a	16.64 a	26.29 a	36.23 a
	24	8.35 a	11.68 a	15.9 a	25.54 a	8.37 a	12.16 a	16.25 a	25.91 a	35.85 a
9	12	8.81 a	12.14 a	16.35 a	25.95 a	8.82 a	12.33 a	16.29 a	25.69 a	35.09 a
	16	8.54 a	11.88 a	16.09 a	25.72 a	8.56 a	12.07 a	16.05 a	25.46 a	34.85 a
	24	8.01 a	11.35 a	15.58 a	25.25 a	8.04 a	11.55 a	15.56 a	24.98 a	34.39 a
10	12	8.62 a	11.64 a	15.79 a	25.14 a	8.64 a	11.81 a	15.66 a	24.79 a	33.55 a
	16	8.29 a	11.32 a	15.48 a	24.86 a	8.32 a	11.5 a	15.37 a	24.51 a	33.27 a
	24	7.63 a	10.68 a	14.86 a	24.3 a	7.68 a	10.88 a	14.78 a	23.94 a	32.72 a
12	12	7.94 a	10.42 a	14.37 a	22.42 a	7.97 a	10.63 a	14.24 a	22.8 a	30.04 a
	16	7.48 a	10 a	13.95 a	22.05 a	7.52 a	10.22 a	13.84 a	22.42 a	29.68 a
	24	6.55 a	9.15 a	13.12 a	21.32 a	6.63 a	9.38 a	13.06 a	21.65 a	28.96 a
14	12	6.81 a	9.18 a	12.56 a	19.44 a	6.88 a	9.34 a	12.8 a	20.26 a	26.22 a
	16	6.23 a	8.64 a	12.05 a	18.99 a	6.32 a	8.82 a	12.31 a	19.79 a	25.79 a
	24	5.07 a	7.57 a	11.02 a	18.11 a	5.2 a	7.78 a	11.31 a	18.85 a	24.92 a
16	12	5.64 a	7.92 a	10.6 a	16.42 a	5.76 a	8 a	11.22 a	17.44 a	22.36 a
	16	4.96 a	7.28 a	10.01 a	15.92 a	5.1 a	7.38 a	10.63 a	16.9 a	21.86 a
	24	3.61 c	6.01 b	8.84 a	14.93 a	3.78 c	6.16 b	9.45 a	15.82 a	20.89 a

a = Deflection Exceeds L/720
b = Deflection Exceeds L/600

c = Deflection Exceeds L/480
d = Deflection Exceeds L/360

e = Deflection Exceeds L/240
f = Deflection Exceeds L/120

If not noted, deflection is less than L/720

Load Bearing Wall Members

Combined Axial & Lateral Load Tables

Refer to Important Table Notes on Page 9

15 Psf Lateral Load: Axial Compression Load (kips)														
Wall Height (ft)	Spacing (in) o.c.	600SG162-(mils)				600SG200-(mils)					600SG250-(mils)			
		33	43	54	68	33	43	54	68	97	43	54	68	97
8	12	3.84 a	5.86 a	7.59 a	9.55 a	5.68 a	8.75 a	11.23 a	14.85 a	21.25 a	8.97 a	12.86 a	17.39 a	27.41 a
	16	3.67 a	5.68 a	7.44 a	9.42 a	5.49 a	8.55 a	11.05 a	14.68 a	21.1 a	8.78 a	12.66 a	17.2 a	27.23 a
	24	3.32 a	5.34 a	7.14 a	9.15 a	5.11 a	8.16 a	10.68 a	14.36 a	20.81 a	8.4 a	12.27 a	16.81 a	26.88 a
9	12	3.7 a	5.72 a	7.47 a	9.45 a	5.53 a	8.59 a	11.08 a	14.72 a	21.13 a	8.82 a	12.7 a	17.24 a	27.27 a
	16	3.48 a	5.5 a	7.28 a	9.28 a	5.29 a	8.34 a	10.85 a	14.51 a	20.95 a	8.58 a	12.45 a	16.99 a	27.05 a
	24	3.05 a	5.06 a	6.9 a	8.94 a	4.81 a	7.84 a	10.39 a	14.1 a	20.58 a	8.09 a	11.95 a	16.5 a	26.6 a
10	12	3.55 a	5.56 a	7.34 a	9.33 a	5.36 a	8.42 a	10.92 a	14.57 a	21 a	8.65 a	12.53 a	17.04 a	27.11 a
	16	3.28 a	5.29 a	7.1 a	9.12 a	5.07 a	8.11 a	10.64 a	14.31 a	20.78 a	8.35 a	12.22 a	16.74 a	26.84 a
	24	2.75 a	4.75 a	6.63 a	8.7 a	4.47 a	7.49 a	10.06 a	13.8 a	20.33 a	7.74 a	11.6 a	16.13 a	26.29 a
12	12	3.2 a	5.21 a	7.03 a	9.05 a	4.97 a	8.01 a	10.54 a	14.23 a	20.71 a	8.25 a	11.49 a	15.7 a	24.79 a
	16	2.81 a	4.82 a	6.69 a	8.75 a	4.54 a	7.57 a	10.13 a	13.87 a	20.38 a	7.82 a	11.07 a	15.29 a	24.42 a
	24	2.04 a	4.03 a	6.01 a	8.14 a	3.69 a	6.68 a	9.31 a	13.13 a	19.73 a	6.95 a	10.22 a	14.47 a	23.69 a
14	12	2.78 a	4.78 a	6.66 a	8.72 a	4.51 a	7.33 a	9.82 a	13.47 a	19.98 a	7.68 a	10.2 a	14.17 a	21.97 a
	16	2.26 a	4.25 a	6.2 a	8.31 a	3.93 a	6.74 a	9.27 a	12.98 a	19.55 a	7.09 a	9.67 a	13.65 a	21.52 a
	24	1.21 c	3.19 b	5.28 a	7.48 a	2.76 b	5.57 a	8.19 a	12.01 a	18.68 a	5.93 a	8.6 a	12.61 a	20.62 a
16	12	2.3 b	4.3 a	6.24 a	8.34 a	3.83 a	6.1 a	8.3 a	11.48 a	17.16 a	6.52 a	9 a	12.25 a	19.03 a
	16	1.62 c	3.6 b	5.64 a	7.8 a	3.1 b	5.41 a	7.66 a	10.92 a	16.66 a	5.83 a	8.36 a	11.64 a	18.52 a
	24	0.25 e	2.21 d	4.44 c	6.73 b	1.63 d	4.03 c	6.4 b	9.79 a	15.67 a	4.44 b	7.07 a	10.42 a	17.48 a

Wall Height (ft)	Spacing (in) o.c.	600SG300-(mils)				
		43	54	68	97	118
8	12	9.01 a	12.96 a	18.02 a	28.21 a	38.61 a
	16	8.82 a	12.76 a	17.82 a	28.03 a	38.43 a
	24	8.45 a	12.38 a	17.44 a	27.66 a	38.06 a
9	12	8.86 a	12.8 a	17.52 a	27.5 a	37.71 a
	16	8.62 a	12.56 a	17.28 a	27.27 a	37.48 a
	24	8.15 a	12.07 a	16.8 a	26.81 a	37.03 a
10	12	8.69 a	12.63 a	16.95 a	26.68 a	36.34 a
	16	8.4 a	12.33 a	16.66 a	26.41 a	36.07 a
	24	7.82 a	11.73 a	16.08 a	25.85 a	35.53 a
12	12	8.31 a	11.7 a	15.6 a	24.79 a	33.14 a
	16	7.89 a	11.29 a	15.2 a	24.42 a	32.78 a
	24	7.04 a	10.46 a	14.42 a	23.67 a	32.07 a
14	12	7.75 a	10.45 a	14.15 a	22.71 a	29.54 a
	16	7.18 a	9.93 a	13.66 a	22.23 a	29.11 a
	24	6.05 a	8.88 a	12.66 a	21.28 a	28.24 a
16	12	6.63 a	9.13 a	12.69 a	19.97 a	25.8 a
	16	5.96 a	8.51 a	12.09 a	19.41 a	25.3 a
	24	4.6 b	7.25 a	10.89 a	18.3 a	24.29 a

a = Deflection Exceeds L/720
b = Deflection Exceeds L/600

c = Deflection Exceeds L/480
d = Deflection Exceeds L/360

e = Deflection Exceeds L/240
f = Deflection Exceeds L/120

If not noted, deflection is less than L/720

Load Bearing Wall Members

Combined Axial & Lateral Load Tables

Refer to Important Table Notes on Page 9

15 psf Lateral Load: Axial Compression Load (kips)										
Wall Height (ft)	Spacing (in) o.c.	800SG162-(mils)				800SG200-(mils)				
		33	43	54	68	33	43	54	68	97
8	12	3.24 a	5.06 a	7.36 a	10.74 a	5.22 a	8.07 a	11.63 a	16.79 a	25.8 a
	16	3.13 a	4.95 a	7.24 a	10.63 a	5.09 a	7.93 a	11.49 a	16.66 a	25.67 a
	24	2.91 a	4.73 a	7.01 a	10.4 a	4.83 a	7.67 a	11.22 a	16.39 a	25.43 a
9	12	3.15 a	4.97 a	7.27 a	10.65 a	5.11 a	7.96 a	11.52 a	16.68 a	25.7 a
	16	3.01 a	4.83 a	7.12 a	10.51 a	4.95 a	7.79 a	11.35 a	16.51 a	25.54 a
	24	2.74 a	4.55 a	6.83 a	10.23 a	4.63 a	7.46 a	11 a	16.18 a	25.23 a
10	12	3.05 a	4.87 a	7.16 a	10.55 a	5 a	7.84 a	11.4 a	16.56 a	25.59 a
	16	2.89 a	4.7 a	6.98 a	10.38 a	4.8 a	7.64 a	11.19 a	16.35 a	25.39 a
	24	2.55 a	4.35 a	6.62 a	10.03 a	4.4 a	7.22 a	10.76 a	15.94 a	25.01 a
12	12	2.83 a	4.64 a	6.93 a	10.32 a	4.74 a	7.57 a	11.12 a	16.29 a	25.33 a
	16	2.59 a	4.39 a	6.67 a	10.07 a	4.45 a	7.27 a	10.81 a	15.99 a	25.05 a
	24	2.11 a	3.89 a	6.15 a	9.57 a	3.88 a	6.68 a	10.19 a	15.38 a	24.5 a
14	12	2.57 a	4.37 a	6.64 a	10.05 a	4.43 a	7.25 a	10.78 a	15.96 a	25.03 a
	16	2.24 a	4.03 a	6.29 a	9.71 a	4.04 a	6.84 a	10.36 a	15.55 a	24.65 a
	24	1.58 a	3.35 a	5.58 a	9.03 a	3.26 a	6.03 a	9.52 a	14.73 a	23.89 a
16	12	2.27 a	4.06 a	6.32 a	9.74 a	4.07 a	6.87 a	10.4 a	15.59 a	24.68 a
	16	1.84 a	3.61 a	5.86 a	9.29 a	3.56 a	6.34 a	9.84 a	15.05 a	24.19 a
	24	0.98 b	2.72 a	4.93 a	8.41 a	2.54 a	5.29 a	8.74 a	13.98 a	23.2 a

Wall Height (ft)	Spacing (in) o.c.	800SG250-(mils)				800SG300-(mils)				
		43	54	68	97	43	54	68	97	118
8	12	8.57 a	12.36 a	17.81 a	30.85 a	8.81 a	12.71 a	18.36 a	31.9 a	43.07 a
	16	8.43 a	12.22 a	17.67 a	30.71 a	8.67 a	12.58 a	18.22 a	31.75 a	42.92 a
	24	8.16 a	11.94 a	17.38 a	30.43 a	8.4 a	12.3 a	17.93 a	31.44 a	42.63 a
9	12	8.46 a	12.24 a	17.69 a	30.74 a	8.7 a	12.6 a	18.25 a	31.78 a	42.95 a
	16	8.29 a	12.07 a	17.51 a	30.56 a	8.53 a	12.43 a	18.06 a	31.59 a	42.77 a
	24	7.95 a	11.72 a	17.15 a	30.2 a	8.19 a	12.08 a	17.7 a	31.2 a	42.4 a
10	12	8.34 a	12.12 a	17.57 a	30.62 a	8.58 a	12.48 a	18.12 a	31.64 a	42.82 a
	16	8.13 a	11.9 a	17.34 a	30.39 a	8.37 a	12.26 a	17.89 a	31.41 a	42.6 a
	24	7.71 a	11.47 a	16.89 a	29.95 a	7.95 a	11.83 a	17.45 a	30.93 a	42.14 a
12	12	8.06 a	11.83 a	17.27 a	30.32 a	8.3 a	12.19 a	17.82 a	31.33 a	42.52 a
	16	7.76 a	11.52 a	16.94 a	30 a	8 a	11.88 a	17.5 a	30.99 a	42.2 a
	24	7.16 a	10.89 a	16.3 a	29.36 a	7.4 a	11.26 a	16.86 a	30.31 a	41.54 a
14	12	7.74 a	11.49 a	16.92 a	29.98 a	7.98 a	11.86 a	17.47 a	30.45 a	41.05 a
	16	7.32 a	11.07 a	16.48 a	29.54 a	7.57 a	11.43 a	17.04 a	29.99 a	40.62 a
	24	6.5 a	10.22 a	15.59 a	28.67 a	6.74 a	10.58 a	16.16 a	29.08 a	39.76 a
16	12	7.36 a	11.1 a	16.51 a	28.43 a	7.6 a	11.47 a	17.07 a	28.51 a	37.97 a
	16	6.82 a	10.55 a	15.94 a	27.89 a	7.06 a	10.91 a	16.5 a	27.94 a	37.44 a
	24	5.74 a	9.43 a	14.78 a	26.8 a	5.99 a	9.81 a	15.35 a	26.81 a	36.39 a

a = Deflection Exceeds L/720
b = Deflection Exceeds L/600

c = Deflection Exceeds L/480
d = Deflection Exceeds L/360

e = Deflection Exceeds L/240
f = Deflection Exceeds L/120

If not noted, deflection is less than L/720

Load Bearing Wall Members

Combined Axial & Lateral Load Tables

Refer to Important Table Notes on Page 9

20 Psf Lateral Load: Axial Compression Load (kips)													
Wall Height (ft)	Spacing (in) o.c.	350SG200-(mils)					350SG250-(mils)				350SG300-(mils)		
		33	43	54	68	97	43	54	68	97	54	68	97
8	12	2.47 a	3.81 a	5.16 a	6.74 a	10.34 a	4.31 a	6 a	7.83 a	11.93 a	6.05 a	8.47 a	13.05 a
	16	2.22 a	3.56 a	4.93 a	6.51 a	10.13 a	4.05 a	5.73 a	7.57 a	11.71 a	5.79 a	8.21 a	12.81 a
	24	1.73 b	3.07 a	4.45 a	6.05 a	9.7 a	3.53 a	5.2 a	7.07 a	11.28 a	5.27 a	7.69 a	12.32 a
9	12	2.14 a	3.36 a	4.61 a	6.06 a	9.28 a	3.86 a	5.37 a	7.05 a	10.77 a	5.54 a	7.81 a	11.89 a
	16	1.85 a	3.07 a	4.33 a	5.79 a	9.03 a	3.55 a	5.06 a	6.76 a	10.51 a	5.23 a	7.49 a	11.6 a
	24	1.26 c	2.49 b	3.78 a	5.25 a	8.54 a	2.93 a	4.43 a	6.17 a	10.01 a	4.6 a	6.87 a	11.04 a
10	12	1.8 b	2.9 a	4.04 a	5.35 a	8.2 a	3.4 a	4.72 a	6.26 a	9.58 a	4.98 a	7.13 a	10.69 a
	16	1.47 c	2.57 b	3.72 a	5.05 a	7.92 a	3.04 a	4.37 a	5.93 a	9.29 a	4.62 a	6.77 a	10.37 a
	24	0.79 e	1.92 d	3.09 c	4.44 b	7.37 a	2.33 c	3.66 b	5.26 a	8.73 a	3.9 a	6.04 a	9.73 a
12	12	1.14 d	2.02 c	2.92 b	3.98 a	6.18 a	2.44 b	3.45 a	4.71 a	7.31 a	3.95 a	5.41 a	8.3 a
	16	0.73 e	1.64 d	2.55 c	3.63 b	5.87 a	2.01 d	3.03 c	4.32 b	6.99 a	3.49 b	4.99 a	7.93 a
	24		0.86 e	1.82 e	2.92 d	5.24 c	1.15 e	2.21 d	3.54 d	6.34 b	2.58 d	4.14 c	7.19 a
14	12	0.57 e	1.3 e	2.03 d	2.89 c	4.65 b	1.61 d	2.42 d	3.45 c	5.57 a	2.81 c	4 b	6.35 a
	16	0.11 f	0.87 e	1.63 e	2.5 d	4.31 c	1.13 e	1.97 e	3.03 d	5.22 b	2.31 d	3.53 c	5.94 b
	24		0.01 f	0.83 f	1.74 e	3.64 e	0.18 f	1.06 f	2.18 e	4.52 d	1.3 e	2.6 e	5.13 d
16	12	0.13 f	0.74 f	1.35 e	2.06 e	3.51 d	0.96 e	1.63 e	2.49 d	4.26 c	1.92 d	2.91 d	4.86 b
	16		0.28 f	0.93 f	1.65 e	3.15 e	0.45 f	1.15 e	2.04 e	3.88 d	1.38 e	2.42 e	4.43 d
	24			0.08 f	0.84 f	2.44 f		0.18 f	1.14 f	3.14 e	0.31 f	1.42 f	3.57 e

Wall Height (ft)	Spacing (in) o.c.	350SG350-(mils)		362SG200-(mils)				
		68	33	43	54	68	97	
8	12	8.45 a	2.58 a	3.99 a	5.41 a	7.14 a	10.95 a	
	16	8.2 a	2.34 a	3.74 a	5.17 a	6.91 a	10.74 a	
	24	7.69 a	1.85 a	3.25 a	4.7 a	6.44 a	10.31 a	
9	12	7.84 a	2.26 a	3.55 a	4.88 a	6.46 a	9.91 a	
	16	7.53 a	1.96 a	3.26 a	4.6 a	6.19 a	9.66 a	
	24	6.92 a	1.38 c	2.68 b	4.04 a	5.65 a	9.16 a	
10	12	7.25 a	1.92 a	3.1 a	4.33 a	5.76 a	8.84 a	
	16	6.89 a	1.58 c	2.77 a	4.01 a	5.45 a	8.55 a	
	24	6.17 a	0.91 d	2.1 c	3.37 b	4.83 a	7.99 a	
12	12	5.86 a	1.26 d	2.21 c	3.21 b	4.36 a	6.74 a	
	16	5.41 a	0.84 e	1.81 d	2.83 c	3.99 b	6.42 a	
	24	4.52 b	0.01 f	1.02 e	2.07 e	3.27 d	5.77 b	
14	12	4.52 a	0.67 e	1.46 d	2.26 d	3.19 c	5.1 a	
	16	4.01 c	0.2 f	1.01 e	1.84 e	2.79 d	4.75 c	
	24	2.98 d		0.13 f	1.01 f	2 e	4.05 d	
16	12	3.32 c	0.2 f	0.86 e	1.53 e	2.3 d	3.87 c	
	16	2.77 d		0.39 f	1.08 f	1.88 e	3.5 d	
	24	1.67 e			0.2 f	1.03 f	2.76 e	

a = Deflection Exceeds L/720
b = Deflection Exceeds L/600

c = Deflection Exceeds L/480
d = Deflection Exceeds L/360

e = Deflection Exceeds L/240
f = Deflection Exceeds L/120

If not noted, deflection is less than L/720

Load Bearing Wall Members

Combined Axial & Lateral Load Tables

Refer to Important Table Notes on Page 9

20 Psf Lateral Load: Axial Compression Load (kips)														
Wall Height (ft)	Spacing (in) o.c.	362SG250-(mils)				362SG300-(mils)			362SG350-(mils)	400SG200-(mils)				
		43	54	68	97	54	68	97	68	33	43	54	68	97
8	12	4.49 a	6.28 a	8.27 a	12.62 a	6.28 a	8.88 a	13.75 a	8.85 a	2.87 a	4.47 a	6.06 a	8.16 a	12.15 a
	16	4.23 a	6.02 a	8.02 a	12.4 a	6.03 a	8.62 a	13.51 a	8.6 a	2.64 a	4.23 a	5.83 a	7.93 a	11.91 a
	24	3.71 a	5.48 a	7.51 a	11.96 a	5.51 a	8.09 a	13.02 a	8.09 a	2.16 a	3.75 a	5.36 a	7.47 a	11.44 a
9	12	4.06 a	5.68 a	7.51 a	11.47 a	5.79 a	8.21 a	12.61 a	8.21 a	2.57 a	4.06 a	5.58 a	7.56 a	11.26 a
	16	3.75 a	5.36 a	7.21 a	11.22 a	5.48 a	7.9 a	12.32 a	7.9 a	2.29 a	3.77 a	5.3 a	7.29 a	10.98 a
	24	3.13 a	4.73 a	6.61 a	10.71 a	4.86 a	7.27 a	11.75 a	7.29 a	1.71 b	3.19 a	4.74 a	6.74 a	10.41 a
10	12	3.6 a	5.05 a	6.72 a	10.29 a	5.27 a	7.53 a	11.42 a	7.61 a	2.25 a	3.63 a	5.06 a	6.92 a	10.31 a
	16	3.24 a	4.69 a	6.38 a	10 a	4.9 a	7.17 a	11.09 a	7.25 a	1.92 a	3.3 a	4.74 a	6.6 a	9.99 a
	24	2.52 c	3.97 b	5.7 a	9.43 a	4.18 a	6.44 a	10.45 a	6.53 a	1.24 c	2.63 b	4.08 a	5.96 a	9.34 a
12	12	2.66 b	3.78 a	5.14 a	7.95 a	4.25 a	5.9 a	9.02 a	6.3 a	1.6 c	2.75 b	3.99 a	5.55 a	8.34 a
	16	2.22 c	3.35 b	4.74 a	7.62 a	3.78 b	5.46 a	8.63 a	5.85 a	1.17 d	2.34 c	3.59 b	5.16 a	7.94 a
	24	1.34 e	2.5 d	3.94 c	6.95 b	2.86 d	4.58 c	7.87 a	4.93 b	0.32 e	1.5 e	2.78 d	4.37 c	7.15 a
14	12	1.79 d	2.68 c	3.79 b	6.09 a	3.1 c	4.38 a	6.92 a	4.95 a	0.97 e	1.92 d	2.96 c	4.18 b	6.42 a
	16	1.3 e	2.21 d	3.35 c	5.72 b	2.58 d	3.9 c	6.5 a	4.42 b	0.47 e	1.45 e	2.5 d	3.75 c	5.98 b
	24	0.32 f	1.27 e	2.47 e	5 d	1.54 e	2.93 d	5.66 c	3.36 d		0.5 f	1.59 e	2.88 e	5.11 d
16	12	1.1 e	1.84 e	2.76 d	4.67 c	2.15 d	3.22 c	5.33 b	3.66 c	0.43 f	1.24 e	2.11 d	3.09 d	4.89 b
	16	0.58 f	1.33 e	2.29 e	4.29 d	1.59 e	2.7 d	4.88 c	3.09 d		0.72 f	1.61 e	2.63 e	4.42 c
	24		0.33 f	1.36 f	3.52 e	0.47 f	1.67 e	3.99 e	1.96 e			0.62 f	1.7 f	3.5 e

Wall Height (ft)	Spacing (in) o.c.	400SG250-(mils)				400SG300-(mils)		
		43	54	68	97	54	68	97
8	12	4.95 a	6.85 a	9.42 a	14.02 a	6.89 a	9.88 a	15.77 a
	16	4.7 a	6.59 a	9.17 a	13.79 a	6.64 a	9.62 a	15.53 a
	24	4.2 a	6.08 a	8.66 a	13.32 a	6.14 a	9.11 a	15.04 a
9	12	4.56 a	6.41 a	8.74 a	13.04 a	6.44 a	9.31 a	14.69 a
	16	4.26 a	6.1 a	8.43 a	12.76 a	6.14 a	9 a	14.4 a
	24	3.65 a	5.48 a	7.82 a	12.2 a	5.53 a	8.38 a	13.82 a
10	12	4.14 a	5.89 a	8.01 a	11.99 a	5.96 a	8.67 a	13.55 a
	16	3.78 a	5.53 a	7.65 a	11.67 a	5.6 a	8.3 a	13.22 a
	24	3.07 a	4.8 a	6.95 a	11.03 a	4.89 a	7.57 a	12.55 a
12	12	3.25 a	4.67 a	6.47 a	9.81 a	4.93 a	7.34 a	11.17 a
	16	2.79 b	4.22 a	6.03 a	9.42 a	4.47 a	6.87 a	10.76 a
	24	1.89 d	3.31 c	5.16 b	8.64 a	3.54 c	5.92 a	9.94 a
14	12	2.34 c	3.49 b	4.93 a	7.67 a	3.96 a	5.66 a	8.82 a
	16	1.81 d	2.97 c	4.44 b	7.24 a	3.4 c	5.13 b	8.37 a
	24	0.77 e	1.94 e	3.46 d	6.37 c	2.27 d	4.06 d	7.45 b
16	12	1.54 e	2.5 d	3.66 c	5.92 a	2.9 c	4.24 b	6.86 a
	16	0.98 e	1.94 e	3.14 d	5.46 c	2.28 d	3.67 d	6.37 b
	24		0.83 f	2.1 e	4.54 d	1.05 e	2.52 e	5.39 d

a = Deflection Exceeds L/720
b = Deflection Exceeds L/600

c = Deflection Exceeds L/480
d = Deflection Exceeds L/360

e = Deflection Exceeds L/240
f = Deflection Exceeds L/120

If not noted, deflection is less than L/720

Load Bearing Wall Members

Combined Axial & Lateral Load Tables

Refer to Important Table Notes on Page 9

20 Psf Lateral Load: Axial Compression Load (kips)													
Wall Height (ft)	Spacing (in) o.c.	400SG350-(mils)			550SG162-(mils)				550SG200-(mils)				
		68	97	118	33	43	54	68	33	43	54	68	97
8	12	9.85 a	16.5 a	21.44 a	3.76 a	5.21 a	6.83 a	8.65 a	5.52 a	8.01 a	10.35 a	13.78 a	19.81 a
	16	9.61 a	16.25 a	21.2 a	3.51 a	4.97 a	6.63 a	8.47 a	5.24 a	7.74 a	10.1 a	13.56 a	19.6 a
	24	9.11 a	15.75 a	20.71 a	2.99 a	4.51 a	6.22 a	8.11 a	4.67 a	7.2 a	9.59 a	13.11 a	19.2 a
9	12	9.29 a	15.54 a	20.04 a	3.56 a	5.02 a	6.67 a	8.51 a	5.29 a	7.8 a	10.15 a	13.61 a	19.65 a
	16	8.98 a	15.24 a	19.75 a	3.23 a	4.73 a	6.41 a	8.28 a	4.94 a	7.45 a	9.83 a	13.32 a	19.39 a
	24	8.38 a	14.63 a	19.17 a	2.58 a	4.14 a	5.9 a	7.82 a	4.23 a	6.76 a	9.19 a	12.75 a	18.88 a
10	12	8.68 a	14.55 a	18.55 a	3.33 a	4.81 a	6.49 a	8.34 a	5.04 a	7.55 a	9.92 a	13.4 a	19.47 a
	16	8.32 a	14.2 a	18.22 a	2.92 a	4.45 a	6.17 a	8.06 a	4.6 a	7.13 a	9.53 a	13.05 a	19.15 a
	24	7.6 a	13.49 a	17.55 a	2.12 a	3.72 a	5.54 a	7.49 a	3.72 a	6.28 a	8.74 a	12.34 a	18.52 a
12	12	7.47 a	12.44 a	15.46 a	2.8 a	4.33 a	6.07 a	7.97 a	4.46 a	6.99 a	9.41 a	12.94 a	19.05 a
	16	7 a	11.99 a	15.05 a	2.22 a	3.81 a	5.62 a	7.56 a	3.83 a	6.38 a	8.84 a	12.43 a	18.6 a
	24	6.06 a	11.09 a	14.23 a	1.06 c	2.76 b	4.71 a	6.74 a	2.56 b	5.16 a	7.7 a	11.41 a	17.69 a
14	12	6.1 a	9.89 a	12.38 a	2.17 b	3.76 a	5.58 a	7.53 a	3.56 a	5.86 a	8.09 a	11.37 a	17.14 a
	16	5.54 a	9.38 a	11.92 a	1.38 d	3.05 b	4.96 a	6.97 a	2.75 c	5.09 a	7.38 a	10.73 a	16.57 a
	24	4.42 c	8.37 b	11 a		1.62 d	3.72 c	5.86 b	1.12 d	3.55 c	5.96 b	9.46 a	15.43 a
16	12	4.79 b	7.72 a	9.77 a	1.44 d	3.1 c	5.01 b	7.02 a	2.49 c	4.51 b	6.48 a	9.28 a	14.2 a
	16	4.16 c	7.18 a	9.28 a	0.41 e	2.17 d	4.2 c	6.29 b	1.55 d	3.63 c	5.67 b	8.57 a	13.57 a
	24	2.91 e	6.09 c	8.3 c		0.3 e	2.58 e	4.84 d		1.87 e	4.05 d	7.14 c	12.29 b

Wall Height (ft)	Spacing (in) o.c.	550SG250-(mils)				550SG300-(mils)				
		43	54	68	97	43	54	68	97	118
8	12	8.77 a	12.1 a	16.31 a	25.91 a	8.78 a	12.57 a	16.64 a	26.29 a	36.23 a
	16	8.49 a	11.82 a	16.04 a	25.67 a	8.51 a	12.3 a	16.38 a	26.04 a	35.98 a
	24	7.92 a	11.26 a	15.5 a	25.17 a	7.96 a	11.74 a	15.85 a	25.52 a	35.47 a
9	12	8.54 a	11.88 a	16.09 a	25.72 a	8.56 a	12.07 a	16.05 a	25.46 a	34.85 a
	16	8.19 a	11.52 a	15.75 a	25.41 a	8.22 a	11.73 a	15.72 a	25.14 a	34.55 a
	24	7.47 a	10.82 a	15.07 a	24.78 a	7.52 a	11.04 a	15.07 a	24.51 a	33.92 a
10	12	8.29 a	11.32 a	15.48 a	24.86 a	8.32 a	11.5 a	15.37 a	24.51 a	33.27 a
	16	7.85 a	10.89 a	15.07 a	24.48 a	7.89 a	11.09 a	14.97 a	24.13 a	32.9 a
	24	6.97 a	10.04 a	14.24 a	23.73 a	7.04 a	10.26 a	14.19 a	23.37 a	32.16 a
12	12	7.48 a	10 a	13.95 a	22.05 a	7.52 a	10.22 a	13.84 a	22.42 a	29.68 a
	16	6.86 a	9.43 a	13.4 a	21.56 a	6.93 a	9.66 a	13.32 a	21.91 a	29.2 a
	24	5.63 a	8.3 a	12.29 a	20.59 a	5.74 a	8.55 a	12.27 a	20.89 a	28.24 a
14	12	6.23 a	8.64 a	12.05 a	18.99 a	6.32 a	8.82 a	12.31 a	19.79 a	25.79 a
	16	5.46 a	7.93 a	11.36 a	18.41 a	5.57 a	8.12 a	11.64 a	19.16 a	25.21 a
	24	3.92 c	6.51 b	10 a	17.23 a	4.08 b	6.74 a	10.32 a	17.91 a	24.06 a
16	12	4.96 a	7.28 a	10.01 a	15.92 a	5.1 a	7.38 a	10.63 a	16.9 a	21.86 a
	16	4.06 c	6.44 b	9.23 a	15.26 a	4.22 b	6.57 a	9.85 a	16.18 a	21.21 a
	24	2.25 d	4.74 d	7.66 c	13.94 a	2.45 d	4.93 c	8.27 b	14.74 a	19.91 a

a = Deflection Exceeds L/720
b = Deflection Exceeds L/600

c = Deflection Exceeds L/480
d = Deflection Exceeds L/360

e = Deflection Exceeds L/240
f = Deflection Exceeds L/120

If not noted, deflection is less than L/720

Load Bearing Wall Members

Combined Axial & Lateral Load Tables

Refer to Important Table Notes on Page 9

20 Psf Lateral Load: Axial Compression Load (kips)														
Wall Height (ft)	Spacing (in) o.c.	600SG162-(mils)				600SG200-(mils)					600SG250-(mils)			
		33	43	54	68	33	43	54	68	97	43	54	68	97
8	12	3.67 a	5.68 a	7.44 a	9.42 a	5.49 a	8.55 a	11.05 a	14.68 a	21.1 a	8.78 a	12.66 a	17.2 a	27.23 a
	16	3.44 a	5.45 a	7.24 a	9.24 a	5.24 a	8.29 a	10.8 a	14.47 a	20.91 a	8.52 a	12.4 a	16.94 a	27 a
	24	2.98 a	4.99 a	6.84 a	8.88 a	4.73 a	7.76 a	10.31 a	14.03 a	20.53 a	8.01 a	11.87 a	16.42 a	26.53 a
9	12	3.48 a	5.5 a	7.28 a	9.28 a	5.29 a	8.34 a	10.85 a	14.51 a	20.95 a	8.58 a	12.45 a	16.99 a	27.05 a
	16	3.2 a	5.21 a	7.03 a	9.05 a	4.97 a	8.01 a	10.54 a	14.23 a	20.71 a	8.25 a	12.12 a	16.66 a	26.75 a
	24	2.62 a	4.62 a	6.52 a	8.59 a	4.33 a	7.35 a	9.93 a	13.68 a	20.22 a	7.6 a	11.45 a	16.01 a	26.16 a
10	12	3.28 a	5.29 a	7.1 a	9.12 a	5.07 a	8.11 a	10.64 a	14.31 a	20.78 a	8.35 a	12.22 a	16.74 a	26.84 a
	16	2.93 a	4.93 a	6.79 a	8.84 a	4.67 a	7.7 a	10.25 a	13.97 a	20.48 a	7.95 a	11.8 a	16.33 a	26.47 a
	24	2.21 a	4.21 a	6.16 a	8.28 a	3.88 a	6.88 a	9.49 a	13.29 a	19.88 a	7.14 a	10.97 a	15.53 a	25.74 a
12	12	2.81 a	4.82 a	6.69 a	8.75 a	4.54 a	7.57 a	10.13 a	13.87 a	20.38 a	7.82 a	11.07 a	15.29 a	24.42 a
	16	2.3 a	4.3 a	6.24 a	8.34 a	3.97 a	6.98 a	9.58 a	13.37 a	19.95 a	7.24 a	10.5 a	14.74 a	23.93 a
	24	1.28 b	3.25 a	5.34 a	7.54 a	2.83 a	5.79 a	8.49 a	12.39 a	19.09 a	6.08 a	9.37 a	13.64 a	22.96 a
14	12	2.26 a	4.25 a	6.2 a	8.31 a	3.93 a	6.74 a	9.27 a	12.98 a	19.55 a	7.09 a	9.67 a	13.65 a	21.52 a
	16	1.56 c	3.54 a	5.59 a	7.76 a	3.15 b	5.96 a	8.55 a	12.33 a	18.97 a	6.32 a	8.96 a	12.95 a	20.92 a
	24	0.17 d	2.13 c	4.36 b	6.66 a	1.6 d	4.39 b	7.1 a	11.03 a	17.82 a	4.76 b	7.53 a	11.57 a	19.72 a
16	12	1.62 c	3.6 b	5.64 a	7.8 a	3.1 b	5.41 a	7.66 a	10.92 a	16.66 a	5.83 a	8.36 a	11.64 a	18.52 a
	16	0.71 d	2.68 c	4.84 b	7.09 a	2.12 d	4.49 b	6.82 a	10.17 a	16 a	4.9 b	7.5 a	10.83 a	17.83 a
	24		0.83 e	3.24 d	5.65 c	0.17 e	2.66 d	5.13 c	8.67 b	14.68 a	3.05 d	5.77 c	9.2 b	16.45 a

Wall Height (ft)	Spacing (in) o.c.	600SG300-(mils)				
		43	54	68	97	118
8	12	8.82 a	12.76 a	17.82 a	28.03 a	38.43 a
	16	8.57 a	12.51 a	17.57 a	27.78 a	38.18 a
	24	8.07 a	11.99 a	17.05 a	27.29 a	37.7 a
9	12	8.62 a	12.56 a	17.28 a	27.27 a	37.48 a
	16	8.31 a	12.23 a	16.96 a	26.97 a	37.18 a
	24	7.67 a	11.58 a	16.32 a	26.35 a	36.59 a
10	12	8.4 a	12.33 a	16.66 a	26.41 a	36.07 a
	16	8.01 a	11.93 a	16.27 a	26.04 a	35.71 a
	24	7.23 a	11.13 a	15.5 a	25.3 a	35 a
12	12	7.89 a	11.29 a	15.2 a	24.42 a	32.78 a
	16	7.32 a	10.73 a	14.68 a	23.91 a	32.3 a
	24	6.2 a	9.63 a	13.64 a	22.91 a	31.36 a
14	12	7.18 a	9.93 a	13.66 a	22.23 a	29.11 a
	16	6.43 a	9.23 a	12.99 a	21.6 a	28.53 a
	24	4.92 a	7.83 a	11.67 a	20.33 a	27.36 a
16	12	5.96 a	8.51 a	12.09 a	19.41 a	25.3 a
	16	5.05 a	7.67 a	11.29 a	18.67 a	24.62 a
	24	3.24 c	6 b	9.69 a	17.18 a	23.28 a

a = Deflection Exceeds L/720
b = Deflection Exceeds L/600

c = Deflection Exceeds L/480
d = Deflection Exceeds L/360

e = Deflection Exceeds L/240
f = Deflection Exceeds L/120

If not noted, deflection is less than L/720

Load Bearing Wall Members

Combined Axial & Lateral Load Tables

Refer to Important Table Notes on Page 9

20 Psf Lateral Load: Axial Compression Load (kips)														
Wall Height (ft)	Spacing (in) o.c.	800SG162-(mils)				800SG200-(mils)					800SG250-(mils)			
		33	43	54	68	33	43	54	68	97	43	54	68	97
8	12	3.13 a	4.95 a	7.24 a	10.63 a	3.13 a	4.95 a	7.24 a	10.63 a	25.67	8.43 a	12.22 a	17.67 a	30.71 a
	16	2.98 a	4.8 a	7.09 a	10.48 a	2.98 a	4.8 a	7.09 a	10.48 a	25.51	8.25 a	12.03 a	17.47 a	30.53 a
	24	2.7 a	4.5 a	6.78 a	10.18 a	2.7 a	4.5 a	6.78 a	10.18 a	25.18	7.9 a	11.66 a	17.09 a	30.15 a
9	12	3.01 a	4.83 a	7.12 a	10.51 a	3.01 a	4.83 a	7.12 a	10.51 a	25.54	8.29 a	12.07 a	17.51 a	30.56 a
	16	2.83 a	4.64 a	6.93 a	10.32 a	2.83 a	4.64 a	6.93 a	10.32 a	25.33	8.06 a	11.83 a	17.27 a	30.32 a
	24	2.47 a	4.26 a	6.54 a	9.95 a	2.47 a	4.26 a	6.54 a	9.95 a	24.92	7.61 a	11.36 a	16.78 a	29.84 a
10	12	2.89 a	4.7 a	6.98 a	10.38 a	2.89 a	4.7 a	6.98 a	10.38 a	25.39	8.13 a	11.9 a	17.34 a	30.39 a
	16	2.66 a	4.47 a	6.74 a	10.15 a	2.66 a	4.47 a	6.74 a	10.15 a	25.14	7.85 a	11.61 a	17.04 a	30.1 a
	24	2.21 a	4 a	6.26 a	9.68 a	2.21 a	4 a	6.26 a	9.68 a	24.62	7.29 a	11.03 a	16.44 a	29.51 a
12	12	2.59 a	4.39 a	6.67 a	10.07 a	2.59 a	4.39 a	6.67 a	10.07 a	25.05	7.76 a	11.52 a	16.94 a	30 a
	16	2.27 a	4.06 a	6.32 a	9.74 a	2.27 a	4.06 a	6.32 a	9.74 a	24.68	7.36 a	11.1 a	16.51 a	29.58 a
	24	1.62 a	3.39 a	5.63 a	9.07 a	1.62 a	3.39 a	5.63 a	9.07 a	23.94	6.55 a	10.27 a	15.65 a	28.73 a
14	12	2.24 a	4.03 a	6.29 a	9.71 a	2.24 a	4.03 a	6.29 a	9.71 a	24.65	7.32 a	11.07 a	16.48 a	29.54 a
	16	1.8 a	3.57 a	5.82 a	9.26 a	1.8 a	3.57 a	5.82 a	9.26 a	24.15	6.77 a	10.5 a	15.89 a	28.96 a
	24	0.93 a	2.66 a	4.88 a	8.35 a	0.93 a	2.66 a	4.88 a	8.35 a	23.13	5.68 a	9.36 a	14.71 a	27.8 a
16	12	1.84 a	3.61 a	5.86 a	9.29 a	1.84 a	3.61 a	5.86 a	9.29 a	24.19	6.82 a	10.55 a	15.94 a	27.89 a
	16	1.27 a	3.02 a	5.24 a	8.7 a	1.27 a	3.02 a	5.24 a	8.7 a	23.53	6.1 a	9.8 a	15.17 a	27.16 a
	24	0.12 c	1.83 b	4.01 a	7.52 a	0.12 c	1.83 b	4.01 a	7.52 a	22.20	4.67 a	8.32 a	13.63 a	25.71 a

Wall Height (ft)	Spacing (in) o.c.	800SG300-(mils)				
		43	54	68	97	118
8	12	8.67 a	12.58 a	18.22 a	31.75 a	42.92 a
	16	8.49 a	12.39 a	18.03 a	31.55 a	42.73 a
	24	8.14 a	12.02 a	17.64 a	31.14 a	42.34 a
9	12	8.53 a	12.43 a	18.06 a	31.59 a	42.77 a
	16	8.3 a	12.19 a	17.82 a	31.33 a	42.52 a
	24	7.85 a	11.73 a	17.34 a	30.82 a	42.03 a
10	12	8.37 a	12.26 a	17.89 a	31.41 a	42.6 a
	16	8.09 a	11.98 a	17.6 a	31.09 a	42.29 a
	24	7.53 a	11.4 a	17 a	30.46 a	41.69 a
12	12	8 a	11.88 a	17.5 a	30.99 a	42.2 a
	16	7.6 a	11.47 a	17.07 a	30.54 a	41.76 a
	24	6.79 a	10.64 a	16.21 a	29.63 a	40.9 a
14	12	7.57 a	11.43 a	17.04 a	29.99 a	40.62 a
	16	7.02 a	10.87 a	16.45 a	29.39 a	40.05 a
	24	5.92 a	9.74 a	15.28 a	28.17 a	38.89 a
16	12	7.06 a	10.91 a	16.5 a	27.94 a	37.44 a
	16	6.35 a	10.18 a	15.73 a	27.19 a	36.74 a
	24	4.91 a	8.7 a	14.21 a	25.68 a	35.34 a

a = Deflection Exceeds L/720
b = Deflection Exceeds L/600

c = Deflection Exceeds L/480
d = Deflection Exceeds L/360

e = Deflection Exceeds L/240
f = Deflection Exceeds L/120

If not noted, deflection is less than L/720

Load Bearing Wall Members

Combined Axial & Lateral Load Tables

Refer to Important Table Notes on Page 9

25 Psf Lateral Load: Axial Compression Load (kips)													
Wall Height (ft)	Spacing (in) o.c.	350SG200-(mils)					350SG250-(mils)				350SG300-(mils)		
		33	43	54	68	97	43	54	68	97	54	68	97
8	12	2.29 a	3.62 a	4.99 a	6.57 a	10.18 a	4.12 a	5.8 a	7.64 a	11.77 a	5.86 a	8.28 a	12.87 a
	16	1.98 a	3.31 a	4.69 a	6.28 a	9.91 a	3.79 a	5.46 a	7.32 a	11.49 a	5.53 a	7.95 a	12.56 a
	24	1.36 c	2.7 b	4.09 a	5.71 a	9.38 a	3.14 a	4.8 a	6.69 a	10.95 a	4.88 a	7.29 a	11.96 a
9	12	1.92 a	3.14 a	4.4 a	5.85 a	9.1 a	3.63 a	5.14 a	6.83 a	10.58 a	5.31 a	7.57 a	11.67 a
	16	1.55 c	2.78 a	4.05 a	5.52 a	8.79 a	3.24 a	4.75 a	6.46 a	10.26 a	4.92 a	7.18 a	11.32 a
	24	0.82 d	2.06 c	3.36 b	4.84 a	8.17 a	2.47 c	3.96 a	5.73 a	9.63 a	4.14 a	6.4 a	10.61 a
10	12	1.55 c	2.66 a	3.8 a	5.12 a	7.99 a	3.13 a	4.45 a	6.01 a	9.36 a	4.71 a	6.86 a	10.45 a
	16	1.13 d	2.25 c	3.41 b	4.74 a	7.65 a	2.69 b	4.01 a	5.6 a	9.01 a	4.26 a	6.41 a	10.05 a
	24	0.28 e	1.42 d	2.62 d	3.99 c	6.96 a	1.79 d	3.13 c	4.76 b	8.31 a	3.36 b	5.5 a	9.25 a
12	12	0.84 e	1.73 d	2.65 c	3.71 b	5.94 a	2.12 c	3.14 b	4.42 a	7.07 a	3.61 b	5.09 a	8.02 a
	16	0.32 e	1.25 e	2.19 d	3.28 c	5.55 b	1.58 d	2.62 d	3.93 c	6.67 a	3.04 c	4.56 b	7.56 a
	24		0.28 f	1.27 e	2.4 e	4.77 d	0.51 e	1.59 e	2.96 d	5.86 c	1.9 e	3.5 d	6.63 c
14	12	0.23 f	0.98 e	1.73 e	2.6 d	4.4 c	1.25 e	2.08 d	3.13 d	5.31 b	2.43 d	3.65 c	6.04 a
	16		0.44 f	1.23 e	2.12 e	3.97 d	0.66 f	1.51 e	2.6 e	4.87 c	1.8 e	3.06 d	5.53 c
	24			0.23 f	1.16 f	3.13 e		0.38 f	1.54 f	3.99 e	0.54 f	1.9 e	4.52 d
16	12		0.4 f	1.03 f	1.75 e	3.24 d	0.58 f	1.27 e	2.15 e	3.98 d	1.52 e	2.54 d	4.54 c
	16			0.5 f	1.24 f	2.79 e		0.67 f	1.59 f	3.51 e	0.84 f	1.92 e	4 d
	24				0.23 f	1.9 f			0.46 f	2.58 f		0.67 f	2.92 e

Wall Height (ft)	Spacing (in) o.c.	350SG350-(mils)		362SG200-(mils)			
		68	33	43	54	68	97
8	12	8.26 a	2.4 a	3.8 a	5.23 a	6.96 a	10.79 a
	16	7.94 a	2.09 a	3.5 a	4.94 a	6.68 a	10.52 a
	24	7.31 a	1.48 c	2.88 a	4.34 a	6.1 a	9.99 a
9	12	7.61 a	2.04 a	3.33 a	4.67 a	6.26 a	9.72 a
	16	7.23 a	1.67 b	2.97 a	4.32 a	5.92 a	9.41 a
	24	6.46 a	0.94 d	2.24 c	3.62 b	5.24 a	8.79 a
10	12	6.98 a	1.67 b	2.85 a	4.09 a	5.53 a	8.63 a
	16	6.53 a	1.25 d	2.43 c	3.69 a	5.14 a	8.28 a
	24	5.63 a	0.4 e	1.6 d	2.89 c	4.37 b	7.57 a
12	12	5.52 a	0.95 e	1.91 d	2.92 c	4.08 b	6.5 a
	16	4.96 a	0.43 e	1.41 e	2.45 d	3.63 c	6.09 a
	24	3.85 c		0.42 f	1.5 e	2.73 e	5.29 c
14	12	4.14 b	0.32 f	1.13 e	1.94 e	2.89 d	4.84 b
	16	3.5 d		0.57 f	1.42 e	2.4 e	4.4 d
	24	2.22 e			0.38 f	1.41 f	3.53 e
16	12	2.91 d		0.51 f	1.19 f	1.98 e	3.59 d
	16	2.22 e			0.64 f	1.45 f	3.13 e
	24	0.85 f				0.4 f	2.21 f

a = Deflection Exceeds L/720
b = Deflection Exceeds L/600

c = Deflection Exceeds L/480
d = Deflection Exceeds L/360

e = Deflection Exceeds L/240
f = Deflection Exceeds L/120

If not noted, deflection is less than L/720

Load Bearing Wall Members

Combined Axial & Lateral Load Tables

Refer to Important Table Notes on Page 9

25 Psf Lateral Load: Axial Compression Load (kips)														
Wall Height (ft)	Spacing (in) o.c.	362SG250-(mils)				362SG250-(mils)			362SG350-(mils)	400SG200-(mils)				
		43	54	68	97	54	68	97	68	33	43	54	68	97
8	12	4.3 a	6.08 a	8.08 a	12.45 a	6.09 a	8.68 a	13.57 a	8.66 a	2.7 a	4.29 a	5.88 a	7.99 a	11.97 a
	16	3.97 a	5.75 a	7.76 a	12.18 a	5.77 a	8.35 a	13.27 a	8.34 a	2.4 a	3.99 a	5.59 a	7.7 a	11.67 a
	24	3.33 a	5.08 a	7.13 a	11.63 a	5.12 a	7.7 a	12.66 a	7.71 a	1.81 a	3.39 a	5.01 a	7.13 a	11.08 a
9	12	3.82 a	5.44 a	7.28 a	11.28 a	5.56 a	7.97 a	12.39 a	7.98 a	2.36 a	3.84 a	5.37 a	7.35 a	11.05 a
	16	3.44 a	5.05 a	6.91 a	10.96 a	5.17 a	7.58 a	12.04 a	7.6 a	2 a	3.48 a	5.02 a	7.01 a	10.7 a
	24	2.66 b	4.26 a	6.16 a	10.32 a	4.39 a	6.8 a	11.32 a	6.83 a	1.28 c	2.76 b	4.32 a	6.32 a	9.99 a
10	12	3.33 a	4.78 a	6.46 a	10.07 a	4.99 a	7.26 a	11.18 a	7.34 a	2 a	3.38 a	4.82 a	6.68 a	10.07 a
	16	2.88 b	4.33 a	6.04 a	9.71 a	4.54 a	6.8 a	10.77 a	6.89 a	1.58 c	2.96 a	4.41 a	6.28 a	9.66 a
	24	1.99 d	3.43 c	5.19 b	9 a	3.64 b	5.89 a	9.96 a	5.99 a	0.74 d	2.12 c	3.6 b	5.49 a	8.85 a
12	12	2.33 c	3.46 b	4.84 a	7.7 a	3.9 a	5.57 a	8.73 a	5.96 a	1.28 d	2.44 c	3.69 b	5.26 a	8.04 a
	16	1.78 d	2.92 c	4.34 b	7.29 a	3.32 c	5.02 b	8.25 a	5.39 a	0.74 e	1.92 d	3.18 c	4.76 b	7.55 a
	24	0.68 e	1.85 e	3.33 d	6.46 c	2.16 d	3.92 d	7.29 b	4.25 c		0.87 e	2.18 e	3.78 d	6.56 b
14	12	1.42 e	2.33 d	3.46 c	5.81 b	2.71 d	4.02 c	6.61 a	4.55 b	0.6 e	1.56 d	2.61 d	3.86 c	6.09 a
	16	0.81 e	1.74 e	2.91 d	5.36 c	2.06 e	3.42 d	6.08 b	3.89 c		0.97 e	2.04 e	3.31 d	5.54 c
	24		0.56 f	1.81 e	4.46 e	0.75 f	2.21 e	5.04 d	2.57 e			0.9 f	2.22 e	4.45 d
16	12	0.71 f	1.46 e	2.41 e	4.38 d	1.73 e	2.83 d	4.99 c	3.23 d	0.02 f	0.85 e	1.73 e	2.74 d	4.54 c
	16	0.05 f	0.83 f	1.82 e	3.9 e	1.03 f	2.19 e	4.43 d	2.52 e		0.2 f	1.12 f	2.16 e	3.96 d
	24			0.65 f	2.94 f		0.9 f	3.32 e	1.11 f				1 f	2.8 e

Wall Height (ft)	Spacing (in) o.c.	400SG250-(mils)				400SG300-(mils)		
		43	54	68	97	54	68	97
8	12	4.76 a	6.66 a	9.23 a	13.85 a	6.7 a	9.69 a	15.59 a
	16	4.45 a	6.34 a	8.91 a	13.55 a	6.39 a	9.37 a	15.29 a
	24	3.82 a	5.7 a	8.28 a	12.97 a	5.77 a	8.73 a	14.68 a
9	12	4.34 a	6.18 a	8.51 a	12.83 a	6.21 a	9.08 a	14.48 a
	16	3.96 a	5.79 a	8.13 a	12.48 a	5.83 a	8.69 a	14.12 a
	24	3.2 a	5.02 a	7.37 a	11.79 a	5.08 a	7.91 a	13.39 a
10	12	3.87 a	5.62 a	7.74 a	11.75 a	5.69 a	8.39 a	13.3 a
	16	3.43 a	5.16 a	7.3 a	11.35 a	5.24 a	7.93 a	12.88 a
	24	2.54 c	4.25 b	6.42 a	10.55 a	4.35 a	7.02 a	12.05 a
12	12	2.91 b	4.33 a	6.14 a	9.52 a	4.58 a	6.99 a	10.87 a
	16	2.34 c	3.77 b	5.6 a	9.03 a	4 b	6.4 a	10.35 a
	24	1.21 e	2.63 d	4.51 c	8.05 b	2.85 d	5.21 c	9.33 a
14	12	1.94 d	3.1 c	4.56 b	7.34 a	3.54 c	5.26 a	8.48 a
	16	1.29 e	2.46 d	3.95 c	6.8 b	2.83 d	4.59 c	7.91 a
	24		1.17 e	2.73 e	5.71 d	1.43 e	3.26 d	6.76 c
16	12	1.12 e	2.08 e	3.27 d	5.58 c	2.44 d	3.81 c	6.5 b
	16	0.41 f	1.39 e	2.62 e	5 d	1.66 e	3.1 d	5.88 c
	24			1.32 f	3.84 e	0.12 f	1.66 e	4.66 e

a = Deflection Exceeds L/720
b = Deflection Exceeds L/600

c = Deflection Exceeds L/480
d = Deflection Exceeds L/360

e = Deflection Exceeds L/240
f = Deflection Exceeds L/120

If not noted, deflection is less than L/720

Load Bearing Wall Members

Combined Axial & Lateral Load Tables

Refer to Important Table Notes on Page 9

25 Psf Lateral Load: Axial Compression Load (kips)													
Wall Height (ft)	Spacing (in) o.c.	400SG350-(mils)			550SG162-(mils)				550SG200-(mils)				
		68	97	118	33	43	54	68	33	43	54	68	97
8	12	9.67 a	16.31 a	21.26 a	3.57 a	5.03 a	6.68 a	8.51 a	5.31 a	7.81 a	10.16 a	13.62 a	19.66 a
	16	9.36 a	16 a	20.96 a	3.25 a	4.74 a	6.43 a	8.29 a	4.96 a	7.47 a	9.85 a	13.33 a	19.4 a
	24	8.73 a	15.37 a	20.35 a	2.6 a	4.16 a	5.92 a	7.83 a	4.25 a	6.79 a	9.22 a	12.77 a	18.9 a
9	12	9.06 a	15.32 a	19.82 a	3.31 a	4.8 a	6.48 a	8.33 a	5.03 a	7.54 a	9.91 a	13.39 a	19.45 a
	16	8.68 a	14.94 a	19.46 a	2.91 a	4.43 a	6.16 a	8.05 a	4.58 a	7.11 a	9.51 a	13.03 a	19.14 a
	24	7.92 a	14.18 a	18.74 a	2.09 a	3.69 a	5.52 a	7.47 a	3.69 a	6.25 a	8.71 a	12.32 a	18.5 a
10	12	8.41 a	14.29 a	18.3 a	3.03 a	4.54 a	6.25 a	8.13 a	4.71 a	7.24 a	9.63 a	13.14 a	19.23 a
	16	7.96 a	13.85 a	17.88 a	2.52 a	4.08 a	5.86 a	7.78 a	4.16 a	6.71 a	9.14 a	12.7 a	18.84 a
	24	7.06 a	12.96 a	17.05 a	1.52 b	3.17 a	5.07 a	7.07 a	3.06 a	5.64 a	8.15 a	11.81 a	18.05 a
12	12	7.11 a	12.11 a	15.15 a	2.36 a	3.94 a	5.73 a	7.66 a	3.99 a	6.54 a	8.98 a	12.56 a	18.71 a
	16	6.53 a	11.54 a	14.64 a	1.64 c	3.28 a	5.16 a	7.15 a	3.2 a	5.77 a	8.27 a	11.92 a	18.14 a
	24	5.35 b	10.42 a	13.61 a	0.19 d	1.97 c	4.02 b	6.13 a	1.61 c	4.24 b	6.85 a	10.65 a	17.01 a
14	12	5.68 a	9.51 a	12.03 a	1.58 c	3.23 b	5.11 a	7.11 a	2.95 b	5.28 a	7.56 a	10.89 a	16.71 a
	16	4.98 b	8.87 a	11.46 a	0.59 d	2.33 c	4.34 c	6.42 a	1.93 d	4.32 c	6.67 a	10.1 a	16 a
	24	3.58 d	7.61 c	10.3 b		0.55 e	2.79 d	5.03 c		2.39 d	4.89 c	8.51 b	14.57 a
16	12	4.32 c	7.31 a	9.4 a	0.67 e	2.4 d	4.4 c	6.47 b	1.78 d	3.85 c	5.88 b	8.75 a	13.72 a
	16	3.54 d	6.63 c	8.79 b		1.24 e	3.39 d	5.56 c	0.61 e	2.75 d	4.86 c	7.85 b	12.93 a
	24	1.97 e	5.28 d	7.56 d			1.37 e	3.75 e		0.55 e	2.84 e	6.06 d	11.34 c

Wall Height (ft)	Spacing (in) o.c.	550SG250-(mils)				550SG250-(mils)				
		43	54	68	97	43	54	68	97	118
8	12	8.56 a	11.89 a	16.11 a	25.73 a	8.57 a	12.37 a	16.45 a	26.1 a	36.04 a
	16	8.2 a	11.54 a	15.77 a	25.42 a	8.23 a	12.02 a	16.12 a	25.78 a	35.72 a
	24	7.5 a	10.84 a	15.09 a	24.8 a	7.55 a	11.32 a	15.46 a	25.14 a	35.09 a
9	12	8.28 a	11.61 a	15.84 a	25.48 a	8.3 a	11.81 a	15.8 a	25.22 a	34.62 a
	16	7.83 a	11.17 a	15.41 a	25.09 a	7.87 a	11.38 a	15.39 a	24.82 a	34.24 a
	24	6.93 a	10.29 a	14.55 a	24.31 a	7.01 a	10.52 a	14.58 a	24.03 a	33.46 a
10	12	7.96 a	11 a	15.17 a	24.58 a	8 a	11.19 a	15.07 a	24.23 a	32.99 a
	16	7.41 a	10.47 a	14.66 a	24.11 a	7.47 a	10.67 a	14.58 a	23.75 a	32.53 a
	24	6.3 a	9.41 a	13.62 a	23.17 a	6.4 a	9.64 a	13.61 a	22.81 a	31.61 a
12	12	7.02 a	9.57 a	13.54 a	21.69 a	7.08 a	9.8 a	13.45 a	22.04 a	29.32 a
	16	6.24 a	8.86 a	12.84 a	21.07 a	6.33 a	9.11 a	12.79 a	21.4 a	28.72 a
	24	4.7 b	7.44 a	11.45 a	19.85 a	4.84 a	7.72 a	11.48 a	20.13 a	27.52 a
14	12	5.65 a	8.11 a	11.54 a	18.55 a	5.76 a	8.3 a	11.81 a	19.32 a	25.36 a
	16	4.69 b	7.22 a	10.68 a	17.82 a	4.83 a	7.43 a	10.98 a	18.54 a	24.63 a
	24	2.77 d	5.44 c	8.97 b	16.35 a	2.96 c	5.7 b	9.33 a	16.97 a	23.19 a
16	12	4.28 b	6.65 a	9.42 a	15.43 a	4.44 b	6.77 a	10.04 a	16.36 a	21.38 a
	16	3.16 d	5.59 c	8.45 b	14.6 a	3.34 c	5.75 b	9.06 a	15.46 a	20.56 a
	24	0.9 e	3.47 d	6.49 d	12.95 b	1.13 e	3.71 d	7.09 c	13.65 a	18.93 a

a = Deflection Exceeds L/720
b = Deflection Exceeds L/600

c = Deflection Exceeds L/480
d = Deflection Exceeds L/360

e = Deflection Exceeds L/240
f = Deflection Exceeds L/120

If not noted, deflection is less than L/720

Load Bearing Wall Members

Combined Axial & Lateral Load Tables

Refer to Important Table Notes on Page 9

25 Psf Lateral Load: Axial Compression Load (kips)														
Wall Height (ft)	Spacing (in) o.c.	600SG162-(mils)				600SG200-(mils)					600SG250-(mils)			
		33	43	54	68	33	43	54	68	97	43	54	68	97
8	12	3.49 a	5.51 a	7.29 a	9.28 a	5.3 a	8.36 a	10.86 a	14.52 a	20.96 a	8.59 a	12.46 a	17 a	27.06 a
	16	3.21 a	5.22 a	7.04 a	9.06 a	4.99 a	8.03 a	10.56 a	14.25 a	20.72 a	8.27 a	12.13 a	16.68 a	26.76 a
	24	2.64 a	4.64 a	6.54 a	8.61 a	4.35 a	7.37 a	9.95 a	13.7 a	20.24 a	7.62 a	11.47 a	16.03 a	26.18 a
9	12	3.27 a	5.28 a	7.09 a	9.11 a	5.05 a	8.09 a	10.62 a	14.3 a	20.77 a	8.33 a	12.2 a	16.74 a	26.83 a
	16	2.91 a	4.91 a	6.77 a	8.82 a	4.65 a	7.68 a	10.23 a	13.96 a	20.46 a	7.93 a	11.78 a	16.34 a	26.45 a
	24	2.19 a	4.18 a	6.14 a	8.25 a	3.85 a	6.85 a	9.46 a	13.27 a	19.86 a	7.11 a	10.94 a	15.52 a	25.71 a
10	12	3.01 a	5.02 a	6.87 a	8.91 a	4.77 a	7.8 a	10.35 a	14.06 a	20.55 a	8.05 a	11.91 a	16.43 a	26.56 a
	16	2.57 a	4.57 a	6.48 a	8.55 a	4.27 a	7.29 a	9.87 a	13.63 a	20.18 a	7.54 a	11.39 a	15.93 a	26.11 a
	24	1.68 a	3.67 a	5.69 a	7.85 a	3.28 a	6.26 a	8.92 a	12.78 a	19.43 a	6.54 a	10.35 a	14.92 a	25.19 a
12	12	2.43 a	4.43 a	6.35 a	8.44 a	4.12 a	7.12 a	9.72 a	13.5 a	20.06 a	7.38 a	10.64 a	14.88 a	24.05 a
	16	1.79 a	3.77 a	5.79 a	7.94 a	3.4 a	6.39 a	9.04 a	12.88 a	19.52 a	6.66 a	9.94 a	14.19 a	23.44 a
	24	0.51 c	2.47 b	4.66 a	6.93 a	1.98 c	4.91 a	7.67 a	11.66 a	18.44 a	5.21 a	8.52 a	12.82 a	22.22 a
14	12	1.73 b	3.72 a	5.74 a	7.9 a	3.34 a	6.15 a	8.73 a	12.5 a	19.12 a	6.51 a	9.13 a	13.13 a	21.07 a
	16	0.86 d	2.83 c	4.97 a	7.21 a	2.37 c	5.18 a	7.82 a	11.68 a	18.4 a	5.54 a	8.25 a	12.26 a	20.32 a
	24		1.06 d	3.44 c	5.84 b	0.44 d	3.22 c	6.01 b	10.06 a	16.95 a	3.6 c	6.47 b	10.53 a	18.83 a
16	12	0.93 d	2.91 c	5.04 b	7.27 a	2.36 c	4.72 b	7.03 a	10.35 a	16.17 a	5.13 a	7.71 a	11.03 a	18 a
	16		1.75 d	4.04 c	6.37 b	1.14 d	3.58 c	5.98 b	9.42 a	15.34 a	3.98 c	6.64 b	10.01 a	17.14 a
	24			2.03 e	4.58 d		1.28 e	3.87 d	7.55 c	13.69 b	1.66 d	4.48 d	7.99 c	15.41 a

Wall Height (ft)	Spacing (in) o.c.	600SG300-(mils)				
		43	54	68	97	118
8	12	8.63 a	12.57 a	17.63 a	27.84 a	38.24 a
	16	8.32 a	12.25 a	17.31 a	27.53 a	37.94 a
	24	7.7 a	11.61 a	16.67 a	26.91 a	37.34 a
9	12	8.39 a	12.32 a	17.04 a	27.04 a	37.26 a
	16	7.99 a	11.91 a	16.64 a	26.66 a	36.89 a
	24	7.2 a	11.1 a	15.85 a	25.89 a	36.14 a
10	12	8.11 a	12.03 a	16.37 a	26.13 a	35.8 a
	16	7.62 a	11.53 a	15.89 a	25.67 a	35.35 a
	24	6.65 a	10.52 a	14.93 a	24.74 a	34.46 a
12	12	7.46 a	10.87 a	14.81 a	24.04 a	32.42 a
	16	6.76 a	10.18 a	14.16 a	23.41 a	31.83 a
	24	5.36 a	8.8 a	12.86 a	22.16 a	30.65 a
14	12	6.61 a	9.4 a	13.16 a	21.75 a	28.67 a
	16	5.67 a	8.53 a	12.33 a	20.96 a	27.94 a
	24	3.79 b	6.78 a	10.68 a	19.37 a	26.49 a
16	12	5.28 a	7.88 a	11.49 a	18.86 a	24.79 a
	16	4.15 b	6.83 a	10.49 a	17.93 a	23.95 a
	24	1.89 d	4.74 c	8.49 b	16.07 a	22.27 a

a = Deflection Exceeds L/720
b = Deflection Exceeds L/600

c = Deflection Exceeds L/480
d = Deflection Exceeds L/360

e = Deflection Exceeds L/240
f = Deflection Exceeds L/120

If not noted, deflection is less than L/720

Load Bearing Wall Members

Combined Axial & Lateral Load Tables

Refer to Important Table Notes on Page 9

25 Psf Lateral Load: Axial Compression Load (kips)														
Wall Height (ft)	Spacing (in) o.c.	800SG162-(mils)				800SG200-(mils)					800SG250-(mils)			
		33	43	54	68	33	43	54	68	97	43	54	68	97
8	12	3.02 a	4.84 a	7.13 a	10.52 a	4.96 a	7.8 a	11.36 a	16.52 a	25.55 a	8.3 a	12.08 a	17.52 a	30.57 a
	16	2.84 a	4.65 a	6.94 a	10.33 a	4.75 a	7.58 a	11.13 a	16.3 a	25.34 a	8.07 a	11.84 a	17.28 a	30.33 a
	24	2.48 a	4.28 a	6.55 a	9.96 a	4.32 a	7.14 a	10.67 a	15.85 a	24.93 a	7.63 a	11.38 a	16.8 a	29.86 a
9	12	2.88 a	4.69 a	6.97 a	10.37 a	4.79 a	7.63 a	11.17 a	16.34 a	25.39 a	8.12 a	11.89 a	17.33 a	30.38 a
	16	2.65 a	4.45 a	6.73 a	10.13 a	4.52 a	7.35 a	10.88 a	16.06 a	25.12 a	7.84 a	11.6 a	17.03 a	30.08 a
	24	2.2 a	3.98 a	6.24 a	9.67 a	3.99 a	6.79 a	10.3 a	15.5 a	24.6 a	7.27 a	11.01 a	16.42 a	29.48 a
10	12	2.72 a	4.52 a	6.8 a	10.2 a	4.6 a	7.43 a	10.97 a	16.15 a	25.2 a	7.92 a	11.69 a	17.12 a	30.17 a
	16	2.44 a	4.23 a	6.5 a	9.91 a	4.27 a	7.08 a	10.61 a	15.8 a	24.88 a	7.57 a	11.32 a	16.74 a	29.8 a
	24	1.88 a	3.65 a	5.9 a	9.34 a	3.61 a	6.39 a	9.9 a	15.1 a	24.23 a	6.87 a	10.6 a	15.99 a	29.06 a
12	12	2.35 a	4.14 a	6.41 a	9.82 a	4.16 a	6.97 a	10.5 a	15.69 a	24.78 a	7.46 a	11.21 a	16.62 a	29.68 a
	16	1.95 a	3.72 a	5.97 a	9.41 a	3.69 a	6.48 a	9.98 a	15.19 a	24.31 a	6.95 a	10.69 a	16.08 a	29.15 a
	24	1.14 a	2.89 a	5.11 a	8.57 a	2.73 a	5.48 a	8.95 a	14.18 a	23.38 a	5.94 a	9.64 a	15 a	28.09 a
14	12	1.91 a	3.69 a	5.94 a	9.37 a	3.65 a	6.44 a	9.94 a	15.14 a	24.27 a	6.91 a	10.64 a	16.03 a	29.11 a
	16	1.36 a	3.12 a	5.35 a	8.8 a	3 a	5.76 a	9.24 a	14.46 a	23.64 a	6.22 a	9.93 a	15.3 a	28.38 a
	24	0.27 c	1.98 a	4.17 a	7.67 a	1.7 a	4.41 a	7.83 a	13.1 a	22.37 a	4.85 a	8.51 a	13.83 a	26.93 a
16	12	1.41 a	3.16 a	5.39 a	8.85 a	3.05 a	5.81 a	9.3 a	14.52 a	23.69 a	6.28 a	9.99 a	15.36 a	27.34 a
	16	0.69 c	2.42 a	4.63 a	8.11 a	2.2 a	4.93 a	8.38 a	13.62 a	22.86 a	5.38 a	9.06 a	14.4 a	26.43 a
	24		0.93 c	3.08 b	6.63 a	0.51 c	3.17 b	6.55 a	11.84 a	21.21 a	3.59 b	7.21 a	12.48 a	24.61 a

Wall Height (ft)	Spacing (in) o.c.	800SG300-(mils)				
		43	54	68	97	118
8	12	8.54 a	12.44 a	18.07 a	31.6 a	42.77 a
	16	8.32 a	12.21 a	17.83 a	31.34 a	42.54 a
	24	7.87 a	11.75 a	17.36 a	30.84 a	42.05 a
9	12	8.36 a	12.25 a	17.88 a	31.4 a	42.58 a
	16	8.08 a	11.96 a	17.58 a	31.08 a	42.28 a
	24	7.51 a	11.38 a	16.98 a	30.44 a	41.67 a
10	12	8.16 a	12.05 a	17.67 a	31.17 a	42.37 a
	16	7.81 a	11.69 a	17.3 a	30.78 a	41.99 a
	24	7.11 a	10.97 a	16.55 a	29.99 a	41.24 a
12	12	7.7 a	11.57 a	17.18 a	30.65 a	41.87 a
	16	7.2 a	11.05 a	16.64 a	30.08 a	41.33 a
	24	6.19 a	10.01 a	15.57 a	28.95 a	40.24 a
14	12	7.15 a	11.01 a	16.6 a	29.54 a	40.19 a
	16	6.47 a	10.3 a	15.86 a	28.78 a	39.47 a
	24	5.1 a	8.89 a	14.4 a	27.26 a	38.03 a
16	12	6.52 a	10.36 a	15.92 a	27.38 a	36.92 a
	16	5.63 a	9.44 a	14.97 a	26.44 a	36.04 a
	24	3.84 a	7.59 a	13.06 a	24.55 a	34.28 a

a = Deflection Exceeds L/720
b = Deflection Exceeds L/600

c = Deflection Exceeds L/480
d = Deflection Exceeds L/360

e = Deflection Exceeds L/240
f = Deflection Exceeds L/120

If not noted, deflection is less than L/720

Load Bearing Wall Members

Combined Axial & Lateral Load Tables

Refer to Important Table Notes on Page 9

30 Psf Lateral Load: Axial Compression Load (kips)													
Wall Height (ft)	Spacing (in) o.c.	350SG200-(mils)					362SG350-(mils)				350SG300-(mils)		
		33	43	54	68	97	43	54	68	97	54	68	97
8	12	2.1 a	3.44 a	4.81 a	6.4 a	10.02 a	3.92 a	5.6 a	7.45 a	11.6 a	5.66 a	8.08 a	12.69 a
	16	1.73 b	3.07 a	4.45 a	6.05 a	9.7 a	3.53 a	5.2 a	7.07 a	11.28 a	5.27 a	7.69 a	12.32 a
	24	0.99 d	2.33 c	3.74 a	5.36 a	9.06 a	2.75 b	4.4 a	6.31 a	10.62 a	4.49 a	6.9 a	11.6 a
9	12	1.7 b	2.93 a	4.19 a	5.65 a	8.91 a	3.4 a	4.9 a	6.61 a	10.39 a	5.07 a	7.34 a	11.46 a
	16	1.26 c	2.49 b	3.78 a	5.25 a	8.54 a	2.93 a	4.43 a	6.17 a	10.01 a	4.6 a	6.87 a	11.04 a
	24	0.38 e	1.62 d	2.94 c	4.44 b	7.8 a	2 c	3.49 b	5.28 a	9.25 a	3.67 b	5.93 a	10.19 a
10	12	1.3 d	2.41 b	3.56 a	4.9 a	7.79 a	2.87 b	4.19 a	5.76 a	9.15 a	4.44 a	6.59 a	10.21 a
	16	0.79 e	1.92 d	3.09 c	4.44 b	7.37 a	2.33 c	3.66 b	5.26 a	8.73 a	3.9 a	6.04 a	9.73 a
	24		0.93 e	2.15 d	3.53 d	6.55 b	1.25 e	2.59 d	4.26 c	7.89 a	2.82 c	4.96 b	8.77 a
12	12	0.53 e	1.44 e	2.37 d	3.45 c	5.71 a	1.79 d	2.83 c	4.12 b	6.83 a	3.27 c	4.77 b	7.74 a
	16		0.86 e	1.82 e	2.92 d	5.24 c	1.15 e	2.21 d	3.54 d	6.34 b	2.58 d	4.14 c	7.19 a
	24			0.73 f	1.87 e	4.31 d		0.97 e	2.38 e	5.38 d	1.22 e	2.86 e	6.07 c
14	12		0.66 f	1.43 e	2.31 e	4.14 d	0.89 e	1.74 e	2.81 d	5.04 c	2.05 d	3.3 d	5.74 b
	16		0.01 f	0.83 f	1.74 e	3.64 e	0.18 f	1.06 f	2.18 e	4.52 d	1.3 e	2.6 e	5.13 d
	24				0.59 f	2.62 f			0.9 f	3.47 e		1.2 f	3.91 e
16	12		0.05 f	0.72 f	1.45 f	2.97 e	0.2 f	0.91 f	1.81 e	3.7 d	1.11 e	2.17 e	4.21 d
	16			0.08 f	0.84 f	2.44 f		0.18 f	1.14 f	3.14 e	0.31 f	1.42 f	3.57 e
	24					1.36 f				2.03 f			2.27 f

Wall Height (ft)	Spacing (in) o.c.	350SG350-(mils)		350SG350-(mils)				
		68	33	43	54	68	97	
8	12	8.07 a	2.21 a	3.62 a	5.05 a	6.79 a	10.63 a	
	16	7.69 a	1.85 a	3.25 a	4.7 a	6.44 a	10.31 a	
	24	6.92 a	1.11 c	2.51 b	3.99 a	5.75 a	9.66 a	
9	12	7.38 a	1.82 b	3.11 a	4.46 a	6.05 a	9.54 a	
	16	6.92 a	1.38 c	2.68 b	4.04 a	5.65 a	9.16 a	
	24	6 a	0.5 e	1.8 d	3.2 c	4.83 b	8.41 a	
10	12	6.71 a	1.42 c	2.6 b	3.85 a	5.3 a	8.41 a	
	16	6.17 a	0.91 d	2.1 c	3.37 b	4.83 a	7.99 a	
	24	5.09 b		1.1 e	2.41 d	3.91 c	7.15 b	
12	12	5.19 a	0.63 e	1.61 d	2.64 d	3.81 c	6.26 a	
	16	4.52 b	0.01 f	1.02 e	2.07 e	3.27 d	5.77 b	
	24	3.17 d			0.93 f	2.18 e	4.81 d	
14	12	3.75 c		0.79 e	1.63 e	2.59 d	4.58 c	
	16	2.98 d		0.13 f	1.01 f	2 e	4.05 d	
	24	1.45 e				0.81 f	3.01 e	
16	12	2.49 e		0.15 f	0.86 f	1.67 e	3.31 e	
	16	1.67 e			0.2 f	1.03 f	2.76 e	
	24	0.03 f					1.65 f	

a = Deflection Exceeds L/720
b = Deflection Exceeds L/600

c = Deflection Exceeds L/480
d = Deflection Exceeds L/360

e = Deflection Exceeds L/240
f = Deflection Exceeds L/120

If not noted, deflection is less than L/720

Load Bearing Wall Members

Combined Axial & Lateral Load Tables

Refer to Important Table Notes on Page 9

30 Psf Lateral Load: Axial Compression Load (kips)														
Wall Height (ft)	Spacing (in) o.c.	362SG250-(mils)				362SG300-(mils)			362SG350-(mils)	400SG200-(mils)				
		43	54	68	97	54	68	97	68	33	43	54	68	97
8	12	4.1 a	5.88 a	7.89 a	12.29 a	5.9 a	8.49 a	13.39 a	8.47 a	2.52 a	4.11 a	5.71 a	7.81 a	11.79 a
	16	3.71 a	5.48 a	7.51 a	11.96 a	5.51 a	8.09 a	13.02 a	8.09 a	2.16 a	3.75 a	5.36 a	7.47 a	11.44 a
	24	2.94 a	4.69 a	6.75 a	11.3 a	4.74 a	7.31 a	12.3 a	7.32 a	1.46 b	3.02 a	4.66 a	6.78 a	10.72 a
9	12	3.59 a	5.21 a	7.06 a	11.09 a	5.32 a	7.74 a	12.18 a	7.75 a	2.14 a	3.63 a	5.16 a	7.15 a	10.84 a
	16	3.13 a	4.73 a	6.61 a	10.71 a	4.86 a	7.27 a	11.75 a	7.29 a	1.71 b	3.19 a	4.74 a	6.74 a	10.41 a
	24	2.2 c	3.79 b	5.72 a	9.94 a	3.93 a	6.33 a	10.9 a	6.37 a	0.85 d	2.33 c	3.9 b	5.91 a	9.56 a
10	12	3.06 a	4.51 a	6.21 a	9.86 a	4.72 a	6.99 a	10.93 a	7.07 a	1.75 b	3.13 a	4.57 a	6.44 a	9.82 a
	16	2.52 c	3.97 b	5.7 a	9.43 a	4.18 a	6.44 a	10.45 a	6.53 a	1.24 c	2.63 b	4.08 a	5.96 a	9.34 a
	24	1.45 d	2.89 b	4.68 c	8.57 a	3.09 c	5.35 b	9.48 a	5.46 a	0.24 e	1.62 d	3.11 c	5.01 b	8.36 a
12	12	2 d	3.14 c	4.54 b	7.45 a	3.55 b	5.24 a	8.44 a	5.62 a	0.96 d	2.13 d	3.39 c	4.96 a	7.74 a
	16	1.34 e	2.5 d	3.94 c	6.95 b	2.86 d	4.58 c	7.87 a	4.93 b	0.32 e	1.5 e	2.78 d	4.37 c	7.15 a
	24	0.02 f	1.21 e	2.73 e	5.96 d	1.47 e	3.26 d	6.72 c	3.56 d		0.25 f	1.57 e	3.2 d	5.96 c
14	12	1.05 e	1.97 e	3.13 d	5.54 c	2.32 d	3.66 c	6.29 b	4.15 c	0.22 f	1.21 e	2.27 d	3.53 d	5.76 b
	16	0.32 f	1.27 e	2.47 e	5 d	1.54 e	2.93 d	5.66 c	3.36 d		0.5 f	1.59 e	2.88 e	5.11 d
	24			1.15 f	3.91 e		1.49 e	4.41 e	1.77 e			0.21 f	1.57 f	3.79 e
16	12	0.31 f	1.08 f	2.06 e	4.09 d	1.31 e	2.45 e	4.66 d	2.81 d		0.46 f	1.36 e	2.39 e	4.19 d
	16		0.33 f	1.36 f	3.52 e	0.47 f	1.67 e	3.99 e	1.96 e			0.62 f	1.7 f	3.5 e
	24				2.37 f		0.13 f	2.65 f	0.25 f				0.3 f	2.1 f

Wall Height (ft)	Spacing (in) o.c.	400SG250-(mils)				400SG300-(mils)		
		43	54	68	97	54	68	97
8	12	4.57 a	6.46 a	9.04 a	13.67 a	6.51 a	9.49 a	15.41 a
	16	4.2 a	6.08 a	8.66 a	13.32 a	6.14 a	9.11 a	15.04 a
	24	3.45 a	5.32 a	7.9 a	12.62 a	5.4 a	8.34 a	14.32 a
9	12	4.11 a	5.95 a	8.28 a	12.62 a	5.99 a	8.85 a	14.26 a
	16	3.65 a	5.48 a	7.82 a	12.2 a	5.53 a	8.38 a	13.82 a
	24	2.75 b	4.55 a	6.91 a	11.37 a	4.63 a	7.45 a	12.96 a
10	12	3.6 a	5.34 a	7.48 a	11.51 a	5.42 a	8.12 a	13.05 a
	16	3.07 a	4.8 a	6.95 a	11.03 a	4.89 a	7.57 a	12.55 a
	24	2 c	3.7 c	5.89 a	10.07 a	3.82 b	6.47 a	11.54 a
12	12	2.57 c	3.99 b	5.82 a	9.22 a	4.24 a	6.63 a	10.56 a
	16	1.89 d	3.31 c	5.16 b	8.64 a	3.54 c	5.92 a	9.94 a
	24	0.53 e	1.95 e	3.85 d	7.46 c	2.16 d	4.5 c	8.71 b
14	12	1.55 e	2.72 d	4.19 c	7.02 a	3.12 c	4.86 b	8.13 a
	16	0.77 e	1.94 e	3.46 d	6.37 c	2.27 d	4.06 d	7.45 b
	24		0.4 f	2 e	5.06 d	0.59 e	2.46 e	6.07 d
16	12	0.69 f	1.66 e	2.88 d	5.23 c	1.97 e	3.38 d	6.13 c
	16		0.83 f	2.1 e	4.54 d	1.05 e	2.52 e	5.39 d
	24			0.54 f	3.15 e		0.81 f	3.92 e

a = Deflection Exceeds L/720
b = Deflection Exceeds L/600

c = Deflection Exceeds L/480
d = Deflection Exceeds L/360

e = Deflection Exceeds L/240
f = Deflection Exceeds L/120

If not noted, deflection is less than L/720

Load Bearing Wall Members

Combined Axial & Lateral Load Tables

Refer to Important Table Notes on Page 9

30 Psf Lateral Load: Axial Compression Load (kips)													
Wall Height (ft)	Spacing (in) o.c.	400SG350-(mils)			550SG162-(mils)			550SG200-(mils)					
		68	97	118	33	43	54	68	33	43	54	68	97
8	12	9.48 a	16.12 a	21.07 a	3.38 a	4.86 a	6.53 a	8.38 a	5.1 a	7.61 a	9.97 a	13.45 a	19.5 a
	16	9.11 a	15.75 a	20.71 a	2.99 a	4.51 a	6.22 a	8.11 a	4.67 a	7.2 a	9.59 a	13.11 a	19.2 a
	24	8.36 a	14.99 a	19.98 a	2.22 a	3.81 a	5.62 a	7.56 a	3.83 a	6.38 a	8.84 a	12.43 a	18.6 a
9	12	8.83 a	15.09 a	19.6 a	3.07 a	4.58 a	6.29 a	8.16 a	4.76 a	7.28 a	9.67 a	13.18 a	19.26 a
	16	8.38 a	14.63 a	19.17 a	2.58 a	4.14 a	5.9 a	7.82 a	4.23 a	6.76 a	9.19 a	12.75 a	18.88 a
	24	7.47 a	13.73 a	18.3 a	1.6 a	3.25 a	5.13 a	7.13 a	3.16 a	5.73 a	8.23 a	11.89 a	18.11 a
10	12	8.14 a	14.02 a	18.05 a	2.72 a	4.27 a	6.02 a	7.92 a	4.38 a	6.92 a	9.33 a	12.87 a	18.99 a
	16	7.6 a	13.49 a	17.55 a	2.12 a	3.72 a	5.54 a	7.49 a	3.72 a	6.28 a	8.74 a	12.34 a	18.52 a
	24	6.53 a	12.43 a	16.55 a	0.91 c	2.63 a	4.59 a	6.64 a	2.4 b	5.01 a	7.56 a	11.28 a	17.58 a
12	12	6.76 a	11.77 a	14.84 a	1.93 b	3.54 a	5.39 a	7.36 a	3.51 a	6.08 a	8.55 a	12.17 a	18.37 a
	16	6.06 a	11.09 a	14.23 a	1.06 c	2.76 b	4.71 a	6.74 a	2.56 b	5.16 a	7.7 a	11.41 a	17.69 a
	24	4.65 c	9.74 a	13 a		1.18 d	3.34 c	5.52 b	0.66 d	3.32 c	6 b	9.88 a	16.33 a
14	12	5.26 b	9.13 a	11.69 a	0.98 d	2.69 c	4.65 b	6.69 a	2.34 c	4.7 b	7.02 a	10.41 a	16.28 a
	16	4.42 c	8.37 b	11 a		1.62 d	3.72 c	5.86 b	1.12 d	3.55 c	5.96 b	9.46 a	15.43 a
	24	2.74 e	6.85 d	9.61 c			1.86 e	4.19 d		1.24 e	3.83 d	7.55 c	13.72 b
16	12	3.85 d	6.91 b	9.03 a		1.7 e	3.8 d	5.93 c	1.08 e	3.19 d	5.27 c	8.21 b	13.25 a
	16	2.91 e	6.09 c	8.3 c		0.3 e	2.58 e	4.84 d		1.87 e	4.05 d	7.14 c	12.29 b
	24	1.03 f	4.46 e	6.82 d			0.16 f	2.66 e			1.63 e	4.99 e	10.38 d

Wall Height (ft)	Spacing (in) o.c.	550SG250-(mils)				550SG300-(mils)				
		43	54	68	97	43	54	68	97	118
8	12	8.35 a	11.68 a	15.9 a	25.54 a	8.37 a	12.16 a	16.25 a	25.91 a	35.85 a
	16	7.92 a	11.26 a	15.5 a	25.17 a	7.96 a	11.74 a	15.85 a	25.52 a	35.47 a
	24	7.07 a	10.42 a	14.69 a	24.44 a	7.14 a	10.9 a	15.06 a	24.76 a	34.71 a
9	12	8.01 a	11.35 a	15.58 a	25.25 a	8.04 a	11.55 a	15.56 a	24.98 a	34.39 a
	16	7.47 a	10.82 a	15.07 a	24.78 a	7.52 a	11.04 a	15.07 a	24.51 a	33.92 a
	24	6.4 a	9.76 a	14.04 a	23.85 a	6.49 a	10 a	14.09 a	23.56 a	32.99 a
10	12	7.63 a	10.68 a	14.86 a	24.3 a	7.68 a	10.88 a	14.78 a	23.94 a	32.72 a
	16	6.97 a	10.04 a	14.24 a	23.73 a	7.04 a	10.26 a	14.19 a	23.37 a	32.16 a
	24	5.64 a	8.77 a	13 a	22.61 a	5.76 a	9.02 a	13.02 a	22.24 a	31.06 a
12	12	6.55 a	9.15 a	13.12 a	21.32 a	6.63 a	9.38 a	13.06 a	21.65 a	28.96 a
	16	5.63 a	8.3 a	12.29 a	20.59 a	5.74 a	8.55 a	12.27 a	20.89 a	28.24 a
	24	3.77 c	6.59 a	10.62 a	19.12 a	3.94 b	6.89 a	10.69 a	19.36 a	26.8 a
14	12	5.07 a	7.57 a	11.02 a	18.11 a	5.2 a	7.78 a	11.31 a	18.85 a	24.92 a
	16	3.92 c	6.51 b	10 a	17.23 a	4.08 b	6.74 a	10.32 a	17.91 a	24.06 a
	24	1.61 d	4.37 d	7.95 c	15.47 a	1.84 d	4.66 c	8.33 b	16.03 a	22.32 a
16	12	3.61 c	6.01 b	8.84 a	14.93 a	3.78 c	6.16 b	9.45 a	15.82 a	20.89 a
	16	2.25 d	4.74 d	7.66 c	13.94 a	2.45 d	4.93 c	8.27 b	14.74 a	19.91 a
	24		2.2 e	5.32 d	11.95 c		2.48 e	5.91 d	12.57 b	17.95 a

a = Deflection Exceeds L/720
b = Deflection Exceeds L/600

c = Deflection Exceeds L/480
d = Deflection Exceeds L/360

e = Deflection Exceeds L/240
f = Deflection Exceeds L/120

If not noted, deflection is less than L/720

Load Bearing Wall Members

Combined Axial & Lateral Load Tables

Refer to Important Table Notes on Page 9

30 Psf Lateral Load: Axial Compression Load (kips)														
Wall Height (ft)	Spacing (in) o.c.	600SG162-(mils)				600SG200-(mils)					600SG250-(mils)			
		33	43	54	68	33	43	54	68	97	43	54	68	97
8	12	3.32 a	5.34 a	7.14 a	9.15 a	5.11 a	8.16 a	10.68 a	14.36 a	20.81 a	8.4 a	12.27 a	16.81 a	26.88 a
	16	2.98 a	4.99 a	6.84 a	8.88 a	4.73 a	7.76 a	10.31 a	14.03 a	20.53 a	8.01 a	11.87 a	16.42 a	26.53 a
	24	2.3 a	4.3 a	6.24 a	8.34 a	3.97 a	6.98 a	9.58 a	13.37 a	19.95 a	7.24 a	11.07 a	15.64 a	25.83 a
9	12	3.05 a	5.06 a	6.9 a	8.94 a	4.81 a	7.84 a	10.39 a	14.1 a	20.58 a	8.09 a	11.95 a	16.5 a	26.6 a
	16	2.62 a	4.62 a	6.52 a	8.59 a	4.33 a	7.35 a	9.93 a	13.68 a	20.22 a	7.6 a	11.45 a	16.01 a	26.16 a
	24	1.76 a	3.74 a	5.76 a	7.91 a	3.37 a	6.35 a	9 a	12.85 a	19.49 a	6.62 a	10.44 a	15.02 a	25.27 a
10	12	2.75 a	4.75 a	6.63 a	8.7 a	4.47 a	7.49 a	10.06 a	13.8 a	20.33 a	7.74 a	11.6 a	16.13 a	26.29 a
	16	2.21 a	4.21 a	6.16 a	8.28 a	3.88 a	6.88 a	9.49 a	13.29 a	19.88 a	7.14 a	10.97 a	15.53 a	25.74 a
	24	1.15 b	3.12 a	5.22 a	7.43 a	2.69 a	5.65 a	8.35 a	12.27 a	18.98 a	5.94 a	9.73 a	14.31 a	24.64 a
12	12	2.04 a	4.03 a	6.01 a	8.14 a	3.69 a	6.68 a	9.31 a	13.13 a	19.73 a	6.95 a	10.22 a	14.47 a	23.69 a
	16	1.28 b	3.25 a	5.34 a	7.54 a	2.83 a	5.79 a	8.49 a	12.39 a	19.09 a	6.08 a	9.37 a	13.64 a	22.96 a
	24		1.69 c	3.99 b	6.32 a	1.12 c	4.02 b	6.84 a	10.92 a	17.79 a	4.35 a	7.68 a	11.99 a	21.49 a
14	12	1.21 c	3.19 b	5.28 a	7.48 a	2.76 b	5.57 a	8.19 a	12.01 a	18.68 a	5.93 a	8.6 a	12.61 a	20.62 a
	16	0.17 d	2.13 c	4.36 b	6.66 a	1.6 d	4.39 b	7.1 a	11.03 a	17.82 a	4.76 b	7.53 a	11.57 a	19.72 a
	24		0 e	2.52 d	5.01 c		2.04 d	4.92 c	9.08 b	16.09 a	2.43 d	5.4 c	9.48 b	17.93 a
16	12	0.25 e	2.21 d	4.44 c	6.73 b	1.63 d	4.03 c	6.4 b	9.79 a	15.67 a	4.44 b	7.07 a	10.42 a	17.48 a
	16		0.83 e	3.24 d	5.65 c	0.17 e	2.66 d	5.13 c	8.67 b	14.68 a	3.05 d	5.77 c	9.2 b	16.45 a
	24			0.83 e	3.5 e			2.6 e	6.43 d	12.7 c	0.27 e	3.19 d	6.77 d	14.38 b

Wall Height (ft)	Spacing (in) o.c.	600SG300-(mils)				
		43	54	68	97	118
8	12	8.45 a	12.38 a	17.44 a	27.66 a	38.06 a
	16	8.07 a	11.99 a	17.05 a	27.29 a	37.7 a
	24	7.32 a	11.22 a	16.28 a	26.54 a	36.98 a
9	12	8.15 a	12.07 a	16.8 a	26.81 a	37.03 a
	16	7.67 a	11.58 a	16.32 a	26.35 a	36.59 a
	24	6.73 a	10.61 a	15.37 a	25.43 a	35.69 a
10	12	7.82 a	11.73 a	16.08 a	25.85 a	35.53 a
	16	7.23 a	11.13 a	15.5 a	25.3 a	35 a
	24	6.06 a	9.92 a	14.35 a	24.19 a	33.92 a
12	12	7.04 a	10.46 a	14.42 a	23.67 a	32.07 a
	16	6.2 a	9.63 a	13.64 a	22.91 a	31.36 a
	24	4.52 a	7.97 a	12.08 a	21.41 a	29.93 a
14	12	6.05 a	8.88 a	12.66 a	21.28 a	28.24 a
	16	4.92 a	7.83 a	11.67 a	20.33 a	27.36 a
	24	2.66 c	5.73 b	9.69 a	18.42 a	25.62 a
16	12	4.6 b	7.25 a	10.89 a	18.3 a	24.29 a
	16	3.24 c	6 b	9.69 a	17.18 a	23.28 a
	24	0.53 e	3.49 d	7.29 c	14.95 a	21.26 a

a = Deflection Exceeds L/720
b = Deflection Exceeds L/600

c = Deflection Exceeds L/480
d = Deflection Exceeds L/360

e = Deflection Exceeds L/240
f = Deflection Exceeds L/120

If not noted, deflection is less than L/720

Load Bearing Wall Members

Combined Axial & Lateral Load Tables

Refer to Important Table Notes on Page 9

30 Psf Lateral Load: Axial Compression Load (kips)														
Wall Height (ft)	Spacing (in) o.c.	800SG162-(mils)				800SG200-(mils)					800SG250-(mils)			
		33	43	54	68	33	43	54	68	97	43	54	68	97
8	12	2.91 a	4.73 a	7.01 a	10.4 a	4.83 a	7.67 a	11.22 a	16.39 a	25.43 a	8.16 a	11.94 a	17.38 a	30.43 a
	16	2.7 a	4.5 a	6.78 a	10.18 a	4.58 a	7.4 a	10.94 a	16.12 a	25.18 a	7.9 a	11.66 a	17.09 a	30.15 a
	24	2.27 a	4.06 a	6.32 a	9.74 a	4.07 a	6.87 a	10.4 a	15.59 a	24.68 a	7.36 a	11.1 a	16.51 a	29.58 a
9	12	2.74 a	4.55 a	6.83 a	10.23 a	4.63 a	7.46 a	11 a	16.18 a	25.23 a	7.95 a	11.72 a	17.15 a	30.2 a
	16	2.47 a	4.26 a	6.54 a	9.95 a	4.31 a	7.12 a	10.65 a	15.84 a	24.92 a	7.61 a	11.36 a	16.78 a	29.84 a
	24	1.93 a	3.7 a	5.95 a	9.38 a	3.66 a	6.45 a	9.96 a	15.16 a	24.29 a	6.93 a	10.66 a	16.05 a	29.13 a
10	12	2.55 a	4.35 a	6.62 a	10.03 a	4.4 a	7.22 a	10.76 a	15.94 a	25.01 a	7.71 a	11.47 a	16.89 a	29.95 a
	16	2.21 a	4 a	6.26 a	9.68 a	4.01 a	6.81 a	10.33 a	15.52 a	24.62 a	7.29 a	11.03 a	16.44 a	29.51 a
	24	1.54 a	3.3 a	5.54 a	8.99 a	3.21 a	5.98 a	9.47 a	14.68 a	23.84 a	6.45 a	10.16 a	15.54 a	28.62 a
12	12	2.11 a	3.89 a	6.15 a	9.57 a	3.88 a	6.68 a	10.19 a	15.38 a	24.5 a	7.16 a	10.89 a	16.3 a	29.36 a
	16	1.62 a	3.39 a	5.63 a	9.07 a	3.31 a	6.08 a	9.57 a	14.78 a	23.94 a	6.55 a	10.27 a	15.65 a	28.73 a
	24	0.66 a	2.38 a	4.59 a	8.07 a	2.16 a	4.89 a	8.33 a	13.58 a	22.82 a	5.34 a	9.02 a	14.35 a	27.45 a
14	12	1.58 a	3.35 a	5.58 a	9.03 a	3.26 a	6.03 a	9.52 a	14.73 a	23.89 a	6.5 a	10.22 a	15.59 a	28.67 a
	16	0.93 a	2.66 a	4.88 a	8.35 a	2.48 a	5.22 a	8.68 a	13.91 a	23.13 a	5.68 a	9.36 a	14.71 a	27.8 a
	24		1.3 b	3.46 a	6.99 a	0.92 b	3.6 a	6.99 a	12.28 a	21.61 a	4.03 a	7.66 a	12.94 a	26.06 a
16	12	0.98 b	2.72 a	4.93 a	8.41 a	2.54 a	5.29 a	8.74 a	13.98 a	23.2 a	5.74 a	9.43 a	14.78 a	26.8 a
	16	0.12 c	1.83 b	4.01 a	7.52 a	1.52 b	4.23 a	7.65 a	12.91 a	22.2 a	4.67 a	8.32 a	13.63 a	25.71 a
	24		0.04 d	2.16 c	5.74 b		2.1 c	5.45 b	10.77 a	20.22 a	2.51 c	6.1 a	11.32 a	23.52 a

Wall Height (ft)	Spacing (in) o.c.	800SG300-(mils)				
		43	54	68	97	118
8	12	8.4 a	12.3 a	17.93 a	31.44 a	42.63 a
	16	8.14 a	12.02 a	17.64 a	31.14 a	42.34 a
	24	7.6 a	11.47 a	17.07 a	30.54 a	41.76 a
9	12	8.19 a	12.08 a	17.7 a	31.2 a	42.4 a
	16	7.85 a	11.73 a	17.34 a	30.82 a	42.03 a
	24	7.17 a	11.03 a	16.61 a	30.05 a	41.3 a
10	12	7.95 a	11.83 a	17.45 a	30.93 a	42.14 a
	16	7.53 a	11.4 a	17 a	30.46 a	41.69 a
	24	6.69 a	10.53 a	16.1 a	29.52 a	40.79 a
12	12	7.4 a	11.26 a	16.86 a	30.31 a	41.54 a
	16	6.79 a	10.64 a	16.21 a	29.63 a	40.9 a
	24	5.59 a	9.39 a	14.92 a	28.27 a	39.59 a
14	12	6.74 a	10.58 a	16.16 a	29.08 a	39.76 a
	16	5.92 a	9.74 a	15.28 a	28.17 a	38.89 a
	24	4.28 a	8.04 a	13.53 a	26.35 a	37.17 a
16	12	5.99 a	9.81 a	15.35 a	26.81 a	36.39 a
	16	4.91 a	8.7 a	14.21 a	25.68 a	35.34 a
	24	2.77 b	6.48 a	11.91 a	23.42 a	33.23 a

a = Deflection Exceeds L/720
b = Deflection Exceeds L/600

c = Deflection Exceeds L/480
d = Deflection Exceeds L/360

e = Deflection Exceeds L/240
f = Deflection Exceeds L/120

If not noted, deflection is less than L/720

Load Bearing Wall Members

Combined Axial & Lateral Load Tables

Refer to Important Table Notes on Page 9

40 Psf Lateral Load: Axial Compression Load (kips)													
Wall Height (ft)	Spacing (in) o.c.	350SG200-(mils)					350SG250-(mils)				350SG300-(mils)		
		33	43	54	68	97	43	54	68	97	54	68	97
8	12	1.73 b	3.07 a	4.45 a	6.05 a	9.7 a	3.53 a	5.2 a	7.07 a	11.28 a	5.27 a	7.69 a	12.32 a
	16	1.24 c	2.58 b	3.98 a	5.59 a	9.27 a	3.01 a	4.66 a	6.57 a	10.84 a	4.75 a	7.16 a	11.84 a
	24	0.25 e	1.59 d	3.02 c	4.67 b	8.41 a	1.97 c	3.6 b	5.56 a	9.97 a	3.71 a	6.12 a	10.87 a
9	12	1.26 c	2.49 b	3.78 a	5.25 a	8.54 a	2.93 a	4.43 a	6.17 a	10.01 a	4.6 a	6.87 a	11.04 a
	16	0.67 d	1.91 d	3.22 c	4.71 b	8.04 a	2.31 c	3.81 b	5.58 a	9.5 a	3.98 a	6.24 a	10.47 a
	24		0.75 e	2.1 d	3.63 d	7.06 b	1.07 d	2.55 d	4.4 c	8.5 a	2.73 c	4.99 b	9.34 a
10	12	0.79 e	1.92 d	3.09 c	4.44 b	7.37 a	2.33 c	3.66 b	5.26 a	8.73 a	3.9 a	6.04 a	9.73 a
	16	0.11 e	1.26 e	2.46 d	3.83 c	6.82 b	1.61 d	2.95 c	4.6 b	8.17 a	3.18 c	5.32 b	9.09 a
	24			1.2 e	2.62 e	5.72 d	0.18 e	1.53 e	3.27 d	7.04 c	1.74 d	3.87 d	7.82 b
12	12		0.86 e	1.82 e	2.92 d	5.24 c	1.15 e	2.21 d	3.54 d	6.34 b	2.58 d	4.14 c	7.19 a
	16		0.08 f	1.09 e	2.22 e	4.62 d	0.29 f	1.38 e	2.77 e	5.7 c	1.67 e	3.29 d	6.44 c
	24				0.82 f	3.37 e			1.22 f	4.41 e		1.59 e	4.96 d
14	12		0.01 f	0.83 f	1.74 e	3.64 e	0.18 f	1.06 f	2.18 e	4.52 d	1.3 e	2.6 e	5.13 d
	16			0.03 f	0.97 f	2.96 e		0.15 f	1.33 f	3.82 e	0.29 f	1.66 e	4.32 e
	24					1.61 f				2.41 f			2.69 f
16	12			0.08 f	0.84 f	2.44 f		0.18 f	1.14 f	3.14 e	0.31 f	1.42 f	3.57 e
	16				0.02 f	1.72 f			0.23 f	2.4 f		0.43 f	2.7 f
	24					0.29				0.91 f			0.98 f

40 Psf Lateral Load: Axial Compression Load (kips)							
Wall Height (ft)	Spacing (in) o.c.	350SG350-(mils)		362SG200-(mils)			
		68	33	43	54	68	97
8	12	7.69 a	1.85 a	3.25 a	4.7 a	6.44 a	10.31 a
	16	7.18 a	1.36 c	2.76 a	4.22 a	5.98 a	9.88 a
	24	6.16 a	0.38 d	1.78 c	3.27 c	5.05 a	9.02 a
9	12	6.92 a	1.38 c	2.68 b	4.04 a	5.65 a	9.16 a
	16	6.31 a	0.79 d	2.1 c	3.48 b	5.1 a	8.66 a
	24	5.08 a		0.93 e	2.35 d	4.01 c	7.66 b
10	12	6.17 a	0.91 d	2.1 c	3.37 b	4.83 a	7.99 a
	16	5.45 a	0.23 e	1.44 d	2.73 d	4.22 c	7.43 a
	24	4.02 c		0.11 e	1.45 e	2.98 d	6.31 c
12	12	4.52 b	0.01 f	1.02 e	2.07 e	3.27 d	5.77 b
	16	3.62 d		0.22 f	1.31 e	2.55 e	5.13 d
	24	1.83 e				1.1 f	3.84 e
14	12	2.98 d		0.13 f	1.01 f	2 e	4.05 d
	16	1.96 e			0.17 f	1.21 f	3.35 e
	24						1.96 f
16	12	1.67 e			0.2 f	1.03 f	2.76 e
	16	0.58 f				0.19 f	2.02 f
	24						0.55 f

a = Deflection Exceeds L/720
b = Deflection Exceeds L/600

c = Deflection Exceeds L/480
d = Deflection Exceeds L/360

e = Deflection Exceeds L/240
f = Deflection Exceeds L/120

If not noted, deflection is less than L/720

Load Bearing Wall Members

Combined Axial & Lateral Load Tables

Refer to Important Table Notes on Page 9

40 Psf Lateral Load: Axial Compression Load (kips)													
Wall Height (ft)	Spacing (in) o.c.	350SG200-(mils)					350SG250-(mils)				350SG300-(mils)		
		33	43	54	68	97	43	54	68	97	54	68	97
8	12	1.73 b	3.07 a	4.45 a	6.05 a	9.7 a	3.53 a	5.2 a	7.07 a	11.28 a	5.27 a	7.69 a	12.32 a
	16	1.24 c	2.58 b	3.98 a	5.59 a	9.27 a	3.01 a	4.66 a	6.57 a	10.84 a	4.75 a	7.16 a	11.84 a
	24	0.25 e	1.59 d	3.02 c	4.67 b	8.41 a	1.97 c	3.6 b	5.56 a	9.97 a	3.71 a	6.12 a	10.87 a
9	12	1.26 c	2.49 b	3.78 a	5.25 a	8.54 a	2.93 a	4.43 a	6.17 a	10.01 a	4.6 a	6.87 a	11.04 a
	16	0.67 d	1.91 d	3.22 c	4.71 b	8.04 a	2.31 c	3.81 b	5.58 a	9.5 a	3.98 a	6.24 a	10.47 a
	24		0.75 e	2.1 d	3.63 d	7.06 b	1.07 d	2.55 d	4.4 c	8.5 a	2.73 c	4.99 b	9.34 a
10	12	0.79 e	1.92 d	3.09 c	4.44 b	7.37 a	2.33 c	3.66 b	5.26 a	8.73 a	3.9 a	6.04 a	9.73 a
	16	0.11 e	1.26 e	2.46 d	3.83 c	6.82 b	1.61 d	2.95 c	4.6 b	8.17 a	3.18 c	5.32 b	9.09 a
	24			1.2 e	2.62 e	5.72 d	0.18 e	1.53 e	3.27 d	7.04 c	1.74 d	3.87 d	7.82 b
12	12		0.86 e	1.82 e	2.92 d	5.24 c	1.15 e	2.21 d	3.54 d	6.34 b	2.58 d	4.14 c	7.19 a
	16		0.08 f	1.09 e	2.22 e	4.62 d	0.29 f	1.38 e	2.77 e	5.7 c	1.67 e	3.29 d	6.44 c
	24				0.82 f	3.37 e			1.22 f	4.41 e		1.59 e	4.96 d
14	12		0.01 f	0.83 f	1.74 e	3.64 e	0.18 f	1.06 f	2.18 e	4.52 d	1.3 e	2.6 e	5.13 d
	16			0.03 f	0.97 f	2.96 e		0.15 f	1.33 f	3.82 e	0.29 f	1.66 e	4.32 e
	24					1.61 f				2.41 f			2.69 f
16	12			0.08 f	0.84 f	2.44 f		0.18 f	1.14 f	3.14 e	0.31 f	1.42 f	3.57 e
	16				0.02 f	1.72 f			0.23 f	2.4 f		0.43 f	2.7 f
	24					0.29				0.91 f			0.98 f

Wall Height (ft)	Spacing (in) o.c.	350SG350-(mils)		362SG200-(mils)				
		68	33	43	54	68	97	
8	12	7.69 a	1.85 a	3.25 a	4.7 a	6.44 a	10.31 a	
	16	7.18 a	1.36 c	2.76 a	4.22 a	5.98 a	9.88 a	
	24	6.16 a	0.38 d	1.78 c	3.27 c	5.05 a	9.02 a	
9	12	6.92 a	1.38 c	2.68 b	4.04 a	5.65 a	9.16 a	
	16	6.31 a	0.79 d	2.1 c	3.48 b	5.1 a	8.66 a	
	24	5.08 a		0.93 e	2.35 d	4.01 c	7.66 b	
10	12	6.17 a	0.91 d	2.1 c	3.37 b	4.83 a	7.99 a	
	16	5.45 a	0.23 e	1.44 d	2.73 d	4.22 c	7.43 a	
	24	4.02 c		0.11 e	1.45 e	2.98 d	6.31 c	
12	12	4.52 b	0.01 f	1.02 e	2.07 e	3.27 d	5.77 b	
	16	3.62 d		0.22 f	1.31 e	2.55 e	5.13 d	
	24	1.83 e				1.1 f	3.84 e	
14	12	2.98 d		0.13 f	1.01 f	2 e	4.05 d	
	16	1.96 e			0.17 f	1.21 f	3.35 e	
	24						1.96 f	
16	12	1.67 e			0.2 f	1.03 f	2.76 e	
	16	0.58 f				0.19 f	2.02 f	
	24						0.55 f	

a = Deflection Exceeds L/720
b = Deflection Exceeds L/600

c = Deflection Exceeds L/480
d = Deflection Exceeds L/360

e = Deflection Exceeds L/240
f = Deflection Exceeds L/120

If not noted, deflection is less than L/720

Load Bearing Wall Members

Combined Axial & Lateral Load Tables

Refer to Important Table Notes on Page 9

40 Psf Lateral Load: Axial Compression Load (kips)														
Wall Height (ft)	Spacing (in) o.c.	362SG250-(mils)				362SG250-(mils)			362SG350-(mils)	400SG200-(mils)				
		43	54	68	97	54	68	97	68	33	43	54	68	97
8	12	3.71 a	5.48 a	7.51 a	11.96 a	5.51 a	8.09 a	13.02 a	8.09 a	2.16 a	3.75 a	5.36 a	7.47 a	11.44 a
	16	3.2 a	4.95 a	7 a	11.52 a	5 a	7.57 a	12.54 a	7.58 a	1.69 b	3.27 a	4.89 a	7.01 a	10.96 a
	24	2.16 c	3.89 b	5.99 a	10.65 a	3.97 a	6.53 a	11.57 a	6.56 a	0.75 d	2.3 b	3.96 a	6.1 a	10.01 a
9	12	3.13 a	4.73 a	6.61 a	10.71 a	4.86 a	7.27 a	11.75 a	7.29 a	1.71 b	3.19 a	4.74 a	6.74 a	10.41 a
	16	2.51 c	4.1 a	6.01 a	10.2 a	4.24 a	6.64 a	11.18 a	6.68 a	1.14 c	2.62 b	4.18 a	6.19 a	9.85 a
	24	1.27 d	2.84 c	4.82 b	9.17 a	2.99 c	5.39 b	10.04 a	5.46 a		1.46 d	3.06 c	5.09 b	8.71 a
10	12	2.52 c	3.97 b	5.7 a	9.43 a	4.18 a	6.44 a	10.45 a	6.53 a	1.24 c	2.63 b	4.08 a	5.96 a	9.34 a
	16	1.81 d	3.25 c	5.02 b	8.85 a	3.45 b	5.71 a	9.8 a	5.81 a	0.57 d	1.95 d	3.43 c	5.33 b	8.68 a
	24	0.37 e	1.81 e	3.66 d	7.7 b	2 d	4.25 c	8.5 b	4.38 c		0.61 e	2.13 d	4.05 d	7.38 b
12	12	1.34 e	2.5 d	3.94 c	6.95 b	2.86 d	4.58 c	7.87 a	4.93 b	0.32 e	1.5 e	2.78 d	4.37 c	7.15 a
	16	0.46 e	1.64 e	3.13 d	6.29 c	1.93 e	3.7 d	7.1 b	4.02 c		0.67 e	1.97 e	3.59 d	6.36 c
	24			1.53 e	4.96 e	0.08 f	1.95 e	5.57 d	2.19 e			0.36 f	2.02 e	4.78 d
14	12	0.32 f	1.27 e	2.47 e	5 d	1.54 e	2.93 d	5.66 c	3.36 d		0.5 f	1.59 e	2.88 e	5.11 d
	16		0.32 f	1.59 e	4.27 e	0.49 f	1.97 e	4.83 d	2.3 e			0.67 f	2.01 e	4.23 e
	24				2.83 f		0.04 f	3.15 e	0.18 f				0.26 f	2.48 f
16	12		0.33 f	1.36 f	3.52 e	0.47 f	1.67 e	3.99 e	1.96 e			0.62 f	1.7 f	3.5 e
	16			0.42 f	2.75 f		0.64 f	3.09 e	0.82 f				0.77 f	2.57 e
	24				1.21 f			1.31 f						0.71 f

Wall Height (ft)	Spacing (in) o.c.	400SG250-(mils)				400SG300-(mils)		
		43	54	68	97	54	68	97
8	12	4.2 a	6.08 a	8.66 a	13.32 a	6.14 a	9.11 a	15.04 a
	16	3.7 a	5.57 a	8.15 a	12.86 a	5.65 a	8.6 a	14.56 a
	24	2.7 b	4.56 a	7.14 a	11.93 a	4.65 a	7.58 a	13.59 a
9	12	3.65 a	5.48 a	7.82 a	12.2 a	5.53 a	8.38 a	13.82 a
	16	3.05 a	4.86 a	7.21 a	11.65 a	4.93 a	7.76 a	13.25 a
	24	1.84 c	3.62 b	6 a	10.54 a	3.72 b	6.51 a	12.09 a
10	12	3.07 a	4.8 a	6.95 a	11.03 a	4.89 a	7.57 a	12.55 a
	16	2.36 c	4.07 b	6.24 a	10.39 a	4.17 a	6.83 a	11.88 a
	24	0.94 d	2.61 d	4.83 c	9.11 a	2.74 c	5.37 b	10.54 a
12	12	1.89 d	3.31 c	5.16 b	8.64 a	3.54 c	5.92 a	9.94 a
	16	0.98 e	2.4 d	4.29 c	7.86 b	2.62 d	4.98 c	9.12 a
	24		0.59 e	2.54 e	6.29 d	0.77 e	3.08 d	7.48 c
14	12	0.77 e	1.94 e	3.46 d	6.37 c	2.27 d	4.06 d	7.45 b
	16		0.91 e	2.49 e	5.5 d	1.15 e	2.99 e	6.53 d
	24			0.54 f	3.76 e		0.85 f	4.69 e
16	12		0.83 f	2.1 e	4.54 d	1.05 e	2.52 e	5.39 d
	16			1.06 f	3.61 e		1.38 f	4.41 e
	24				1.76 f			2.45 f

a = Deflection Exceeds L/720
b = Deflection Exceeds L/600

c = Deflection Exceeds L/480
d = Deflection Exceeds L/360

e = Deflection Exceeds L/240
f = Deflection Exceeds L/120

If not noted, deflection is less than L/720

Load Bearing Wall Members

Combined Axial & Lateral Load Tables

Refer to Important Table Notes on Page 9

40 Psf Lateral Load: Axial Compression Load (kips)													
Wall Height (ft)	Spacing (in) o.c.	400SG350-(mils)			550SG162-(mils)				550SG200-(mils)				
		68	97	118	33	43	54	68	33	43	54	68	97
8	12	9.11 a	15.75 a	20.71 a	2.99 a	4.51 a	6.22 a	8.11 a	4.67 a	7.2 a	9.59 a	13.11 a	19.2 a
	16	8.61 a	15.24 a	20.23 a	2.47 a	4.04 a	5.82 a	7.74 a	4.11 a	6.65 a	9.09 a	12.66 a	18.8 a
	24	7.61 a	14.24 a	19.26 a	1.44 a	3.11 a	5.01 a	7.02 a	2.98 a	5.57 a	8.08 a	11.75 a	17.99 a
9	12	8.38 a	14.63 a	19.17 a	2.58 a	4.14 a	5.9 a	7.82 a	4.23 a	6.76 a	9.19 a	12.75 a	18.88 a
	16	7.77 a	14.03 a	18.59 a	1.93 a	3.54 a	5.39 a	7.36 a	3.51 a	6.08 a	8.55 a	12.17 a	18.37 a
	24	6.56 a	12.82 a	17.43 a	0.62 c	2.36 a	4.37 a	6.44 a	2.09 a	4.7 a	7.28 a	11.03 a	17.35 a
10	12	7.6 a	13.49 a	17.55 a	2.12 a	3.72 a	5.54 a	7.49 a	3.72 a	6.28 a	8.74 a	12.34 a	18.52 a
	16	6.89 a	12.78 a	16.88 a	1.31 b	2.99 a	4.91 a	6.93 a	2.84 a	5.43 a	7.95 a	11.64 a	17.89 a
	24	5.45 b	11.37 a	15.55 a		1.53 c	3.65 b	5.79 a	1.08 c	3.73 b	6.38 a	10.22 a	16.63 a
12	12	6.06 a	11.09 a	14.23 a	1.06 c	2.76 b	4.71 a	6.74 a	2.56 b	5.16 a	7.7 a	11.41 a	17.69 a
	16	5.12 b	10.19 a	13.41 a		1.71 d	3.8 c	5.93 a	1.3 d	3.94 c	6.57 a	10.39 a	16.78 a
	24	3.24 d	8.39 c	11.76 b			1.98 d	4.29 c		1.49 d	4.3 c	8.36 b	14.97 a
14	12	4.42 c	8.37 b	11 a		1.62 d	3.72 c	5.86 b	1.12 d	3.55 c	5.96 b	9.46 a	15.43 a
	16	3.3 d	7.35 c	10.08 b		0.19 e	2.48 d	4.75 d		2.01 d	4.54 d	8.19 c	14.29 a
	24	1.06 e	5.32 e	8.23 d			0.01 e	2.52 e			1.69 e	5.65 d	12 c
16	12	2.91 e	6.09 c	8.3 c		0.3 e	2.58 e	4.84 d		1.87 e	4.05 d	7.14 c	12.29 b
	16	1.65 e	5.01 d	7.31 d			0.97 e	3.39 e		0.11 e	2.44 e	5.71 d	11.02 c
	24		2.83 e	5.34 e				0.48 f				2.85 e	8.47 e

Wall Height (ft)	Spacing (in) o.c.	550SG250-(mils)				550SG300-(mils)				
		43	54	68	97	43	54	68	97	118
8	12	7.92 a	11.26 a	15.5 a	25.17 a	7.96 a	11.74 a	15.85 a	25.52 a	35.47 a
	16	7.35 a	10.7 a	14.96 a	24.68 a	7.41 a	11.18 a	15.32 a	25.01 a	34.96 a
	24	6.22 a	9.59 a	13.87 a	23.7 a	6.32 a	10.07 a	14.27 a	23.99 a	33.95 a
9	12	7.47 a	10.82 a	15.07 a	24.78 a	7.52 a	11.04 a	15.07 a	24.51 a	33.92 a
	16	6.75 a	10.11 a	14.38 a	24.16 a	6.83 a	10.35 a	14.41 a	23.87 a	33.3 a
	24	5.32 a	8.7 a	13.01 a	22.91 a	5.45 a	8.97 a	13.11 a	22.61 a	32.06 a
10	12	6.97 a	10.04 a	14.24 a	23.73 a	7.04 a	10.26 a	14.19 a	23.37 a	32.16 a
	16	6.08 a	9.2 a	13.41 a	22.98 a	6.18 a	9.43 a	13.41 a	22.62 a	31.43 a
	24	4.31 a	7.5 a	11.76 a	21.48 a	4.48 a	7.78 a	11.84 a	21.1 a	29.96 a
12	12	5.63 a	8.3 a	12.29 a	20.59 a	5.74 a	8.55 a	12.27 a	20.89 a	28.24 a
	16	4.39 b	7.16 a	11.17 a	19.61 a	4.54 a	7.44 a	11.22 a	19.87 a	27.28 a
	24	1.92 d	4.89 c	8.95 b	17.65 a	2.16 c	5.22 b	9.12 a	17.83 a	25.36 a
14	12	3.92 c	6.51 b	10 a	17.23 a	4.08 b	6.74 a	10.32 a	17.91 a	24.06 a
	16	2.38 d	5.08 c	8.63 b	16.06 a	2.59 d	5.35 c	8.99 a	16.65 a	22.9 a
	24		2.24 e	5.9 d	13.71 b		2.58 d	6.34 c	14.14 b	20.59 a
16	12	2.25 d	4.74 d	7.66 c	13.94 a	2.45 d	4.93 c	8.27 b	14.74 a	19.91 a
	16	0.45 e	3.05 e	6.1 d	12.61 b	0.69 e	3.3 d	6.7 c	13.29 b	18.6 a
	24			2.97 e	9.97 d		0.03 e	3.55 e	10.41 d	15.99 c

a = Deflection Exceeds L/720
b = Deflection Exceeds L/600

c = Deflection Exceeds L/480
d = Deflection Exceeds L/360

e = Deflection Exceeds L/240
f = Deflection Exceeds L/120

If not noted, deflection is less than L/720

Load Bearing Wall Members

Combined Axial & Lateral Load Tables

Refer to Important Table Notes on Page 9

40 Psf Lateral Load: Axial Compression Load (kips)														
Wall Height (ft)	Spacing (in) o.c.	600SG162-(mils)				600SG200-(mils)					600SG250-(mils)			
		33	43	54	68	33	43	54	68	97	43	54	68	97
8	12	2.98 a	4.99 a	6.84 a	8.88 a	4.73 a	7.76 a	10.31 a	14.03 a	20.53 a	8.01 a	11.87 a	16.42 a	26.53 a
	16	2.53 a	4.53 a	6.44 a	8.52 a	4.23 a	7.24 a	9.83 a	13.59 a	20.14 a	7.5 a	11.34 a	15.9 a	26.06 a
	24	1.62 a	3.6 a	5.64 a	7.8 a	3.21 a	6.19 a	8.85 a	12.72 a	19.37 a	6.47 a	10.28 a	14.87 a	25.13 a
9	12	2.62 a	4.62 a	6.52 a	8.59 a	4.33 a	7.35 a	9.93 a	13.68 a	20.22 a	7.6 a	11.45 a	16.01 a	26.16 a
	16	2.04 a	4.03 a	6.01 a	8.14 a	3.69 a	6.68 a	9.31 a	13.13 a	19.73 a	6.95 a	10.78 a	15.35 a	25.57 a
	24	0.89 b	2.86 a	5 a	7.23 a	2.41 a	5.35 a	8.08 a	12.03 a	18.76 a	5.65 a	9.44 a	14.04 a	24.38 a
10	12	2.21 a	4.21 a	6.16 a	8.28 a	3.88 a	6.88 a	9.49 a	13.29 a	19.88 a	7.14 a	10.97 a	15.53 a	25.74 a
	16	1.5 a	3.49 a	5.54 a	7.71 a	3.09 a	6.06 a	8.73 a	12.61 a	19.28 a	6.34 a	10.15 a	14.72 a	25.01 a
	24	0.08 c	2.04 b	4.29 a	6.59 a	1.5 b	4.42 a	7.21 a	11.25 a	18.08 a	4.73 a	8.49 a	13.1 a	23.55 a
12	12	1.28 b	3.25 a	5.34 a	7.54 a	2.83 a	5.79 a	8.49 a	12.39 a	19.09 a	6.08 a	9.37 a	13.64 a	22.96 a
	16	0.25 d	2.21 c	4.44 a	6.73 a	1.69 c	4.61 a	7.39 a	11.41 a	18.22 a	4.92 a	8.24 a	12.54 a	21.98 a
	24		0.13 d	2.63 c	5.11 c		2.25 c	5.2 c	9.45 a	16.5 a	2.61 c	5.98 b	10.35 a	20.03 a
14	12	0.17 d	2.13 c	4.36 b	6.66 a	1.6 d	4.39 b	7.1 a	11.03 a	17.82 a	4.76 b	7.53 a	11.57 a	19.72 a
	16		0.71 d	3.13 d	5.56 c	0.05 e	2.83 d	5.65 c	9.73 b	16.67 a	3.21 c	6.11 b	10.18 a	18.53 a
	24			0.68 e	3.37 d			2.74 d	7.13 d	14.36 b	0.1 e	3.27 d	7.4 c	16.13 a
16	12		0.83 e	3.24 d	5.65 c	0.17 e	2.66 d	5.13 c	8.67 b	14.68 a	3.05 d	5.77 c	9.2 b	16.45 a
	16			1.63 e	4.22 d		0.82 e	3.45 d	7.17 d	13.36 b	1.2 e	4.05 d	7.58 c	15.06 a
	24				1.35 e			0.07 e	4.18 e	10.72 d		0.61 e	4.34 e	12.3 c

Wall Height (ft)	Spacing (in) o.c.	600SG300-(mils)				
		43	54	68	97	118
8	12	8.07 a	11.99 a	17.05 a	27.29 a	37.7 a
	16	7.57 a	11.48 a	16.54 a	26.79 a	37.22 a
	24	6.58 a	10.45 a	15.51 a	25.8 a	36.25 a
9	12	7.67 a	11.58 a	16.32 a	26.35 a	36.59 a
	16	7.04 a	10.93 a	15.69 a	25.74 a	35.99 a
	24	5.78 a	9.63 a	14.41 a	24.52 a	34.79 a
10	12	7.23 a	11.13 a	15.5 a	25.3 a	35 a
	16	6.45 a	10.32 a	14.74 a	24.56 a	34.28 a
	24	4.89 a	8.72 a	13.2 a	23.08 a	32.85 a
12	12	6.2 a	9.63 a	13.64 a	22.91 a	31.36 a
	16	5.08 a	8.52 a	12.6 a	21.91 a	30.41 a
	24	2.83 b	6.31 a	10.51 a	19.91 a	28.51 a
14	12	4.92 a	7.83 a	11.67 a	20.33 a	27.36 a
	16	3.41 c	6.43 b	10.35 a	19.06 a	26.2 a
	24	0.39 d	3.64 d	7.7 c	16.51 a	23.87 a
16	12	3.24 c	6 b	9.69 a	17.18 a	23.28 a
	16	1.43 d	4.32 c	8.09 b	15.69 a	21.93 a
	24		0.98 e	4.88 d	12.72 c	19.24 b

a = Deflection Exceeds L/720
b = Deflection Exceeds L/600

c = Deflection Exceeds L/480
d = Deflection Exceeds L/360

e = Deflection Exceeds L/240
f = Deflection Exceeds L/120

If not noted, deflection is less than L/720

Load Bearing Wall Members

Combined Axial & Lateral Load Tables

Refer to Important Table Notes on Page 9

40 Psf Lateral Load: Axial Compression Load (kips)														
Wall Height (ft)	Spacing (in) o.c.	800SG162-(mils)				800SG200-(mils)					800SG250-(mils)			
		33	43	54	68	33	43	54	68	97	43	54	68	97
8	12	2.7 a	4.5 a	6.78 a	10.18 a	4.58 a	7.4 a	10.94 a	16.12 a	25.18 a	7.9 a	11.66 a	17.09 a	30.15 a
	16	2.41 a	4.2 a	6.47 a	9.89 a	4.24 a	7.05 a	10.58 a	15.76 a	24.85 a	7.54 a	11.29 a	16.7 a	29.77 a
	24	1.84 a	3.61 a	5.86 a	9.29 a	3.56 a	6.34 a	9.84 a	15.05 a	24.19 a	6.82 a	10.55 a	15.94 a	29.01 a
9	12	2.47 a	4.26 a	6.54 a	9.95 a	4.31 a	7.12 a	10.65 a	15.84 a	24.92 a	7.61 a	11.36 a	16.78 a	29.84 a
	16	2.11 a	3.89 a	6.15 a	9.57 a	3.88 a	6.68 a	10.19 a	15.38 a	24.5 a	7.16 a	10.89 a	16.3 a	29.36 a
	24	1.38 a	3.14 a	5.37 a	8.82 a	3.02 a	5.78 a	9.26 a	14.48 a	23.66 a	6.25 a	9.96 a	15.32 a	28.41 a
10	12	2.21 a	4 a	6.26 a	9.68 a	4.01 a	6.81 a	10.33 a	15.52 a	24.62 a	7.29 a	11.03 a	16.44 a	29.51 a
	16	1.77 a	3.54 a	5.78 a	9.22 a	3.48 a	6.26 a	9.75 a	14.96 a	24.1 a	6.73 a	10.45 a	15.84 a	28.91 a
	24	0.87 a	2.61 a	4.82 a	8.3 a	2.41 a	5.15 a	8.61 a	13.85 a	23.07 a	5.61 a	9.3 a	14.64 a	27.73 a
12	12	1.62 a	3.39 a	5.63 a	9.07 a	3.31 a	6.08 a	9.57 a	14.78 a	23.94 a	6.55 a	10.27 a	15.65 a	28.73 a
	16	0.98 a	2.72 a	4.93 a	8.41 a	2.54 a	5.29 a	8.74 a	13.98 a	23.2 a	5.74 a	9.43 a	14.78 a	27.88 a
	24		1.38 a	3.55 a	7.07 a	1.01 a	3.7 a	7.1 a	12.38 a	21.71 a	4.13 a	7.76 a	13.05 a	26.17 a
14	12	0.93 a	2.66 a	4.88 a	8.35 a	2.48 a	5.22 a	8.68 a	13.91 a	23.13 a	5.68 a	9.36 a	14.71 a	27.8 a
	16	0.05 c	1.75 a	3.93 a	7.45 a	1.44 b	4.14 a	7.55 a	12.82 a	22.12 a	4.58 a	8.23 a	13.53 a	26.65 a
	24			2.05 c	5.63 a		1.97 c	5.31 a	10.64 a	20.09 a	2.38 b	5.96 a	11.18 a	24.33 a
16	12	0.12 c	1.83 b	4.01 a	7.52 a	1.52 b	4.23 a	7.65 a	12.91 a	22.2 a	4.67 a	8.32 a	13.63 a	25.71 a
	16		0.64 c	2.78 c	6.33 a	0.17 d	2.81 c	6.18 a	11.49 a	20.88 a	3.23 b	6.84 a	12.09 a	24.25 a
	24			0.31 d	3.97 c			3.25 c	8.63 b	18.24 a	0.36 d	3.87 c	9.01 b	21.34 a

40 Psf Lateral Load: Axial Compression Load (kips)						
Wall Height (ft)	Spacing (in) o.c.	800SG300-(mils)				
		43	54	68	97	118
8	12	8.14 a	12.02 a	17.64 a	31.14 a	42.34 a
	16	7.78 a	11.65 a	17.26 a	30.74 a	41.96 a
	24	7.06 a	10.91 a	16.5 a	29.93 a	41.18 a
9	12	7.85 a	11.73 a	17.34 a	30.82 a	42.03 a
	16	7.4 a	11.26 a	16.86 a	30.31 a	41.54 a
	24	6.49 a	10.32 a	15.89 a	29.29 a	40.57 a
10	12	7.53 a	11.4 a	17 a	30.46 a	41.69 a
	16	6.97 a	10.82 a	16.4 a	29.83 a	41.09 a
	24	5.85 a	9.67 a	15.21 a	28.57 a	39.88 a
12	12	6.79 a	10.64 a	16.21 a	29.63 a	40.9 a
	16	5.99 a	9.81 a	15.35 a	28.72 a	40.03 a
	24	4.38 a	8.14 a	13.63 a	26.91 a	38.29 a
14	12	5.92 a	9.74 a	15.28 a	28.17 a	38.89 a
	16	4.82 a	8.6 a	14.11 a	26.95 a	37.75 a
	24	2.63 a	6.34 a	11.77 a	24.53 a	35.44 a
16	12	4.91 a	8.7 a	14.21 a	25.68 a	35.34 a
	16	3.48 a	7.22 a	12.68 a	24.18 a	33.93 a
	24	0.62 c	4.26 b	9.62 a	21.16 a	31.13 a

a = Deflection Exceeds L/720
b = Deflection Exceeds L/600

c = Deflection Exceeds L/480
d = Deflection Exceeds L/360

e = Deflection Exceeds L/240
f = Deflection Exceeds L/120

If not noted, deflection is less than L/720

Load Bearing Wall Members SigmaStud® STC Ratings and UL Assemblies

Fire Ratings

SigmaStud® projects have revealed that a proprietary shaped load-bearing member does not affect the fire rating of a wall versus using standard (S) section studs. The general requirements of steel studs in a fire-rated load bearing wall includes that the studs shall be designed in accordance with the current edition of the *AISI Specification for the Design of Cold-Formed Steel Structural Members*. Studs shall be corrosion-protected, have a minimum stud size of 3.5 inches, minimum thickness of 33 mil (20 ga), and maximum spacing between studs shall not exceed 16 or 24 inches.

UL's Fire Resistance Ratings vary from 45 minutes to 4 hours. The full report for each Fire Resistance Rating can be found on UL's website (www.ul.com). To obtain the report, click on Online Certifications Directory under Tools at the bottom of the UL homepage. Search by UL File Number. Click on the file link to view report. For technical assistance, please contact UL directly at 1-877-ULHELPS.

A complete listing of all UL Fire Resistance Ratings for use with cold-formed steel studs can be obtained through UL; we have simply attempted to outline the more commonly-used ratings below.

Load Bearing Fire Rated Details

- U404 - LOADBEARING (1 or 2 hr) - Interior Wall
- U407 - LOADBEARING (1 hr) - Interior Wall
- U418 - LOADBEARING (45 min - 2 hr) - Exterior Wall
- U423 - LOADBEARING (45min - 2 hr) - Interior Wall
- U424 - LOADBEARING (45 min - 2 hr) - Exterior Wall
- U425 - LOADBEARING (45 min - 2 hr) - Exterior Wall with detail for Interior
- U426 - LOADBEARING (3 hr) - Interior Wall
- U432 - LOADBEARING (1 hr) - Interior Wall
- U434 - LOADBEARING (1 hr) - Interior Wall
- U440 - LOADBEARING (1 hr) - Interior Wall
- U460 - LOADBEARING (1 hr) - Interior Wall
- U462 - LOADBEARING (3 hr) - Interior Wall
- U473 - LOADBEARING (1 hr) - Interior Wall
- U477 - LOADBEARING (2 hr) - Interior Wall
- U485 - LOADBEARING (1 hr) - Interior Wall
- U487 - LOADBEARING (1 hr) - Interior Wall
- U490 - LOADBEARING (3 or 4 hr) - Interior Wall
- U530 - LOADBEARING (4 hr) - Interior Wall
- V415 - LOADBEARING (2 hr) - Interior Wall
- V420 - LOADBEARING (2 hr) - Interior Wall
- V432 - LOADBEARING (1 hr) - Exterior Wall
- V434 - LOADBEARING (1 hr) - Interior Wall
- V446 - LOADBEARING (1 or 2 hr) - Interior

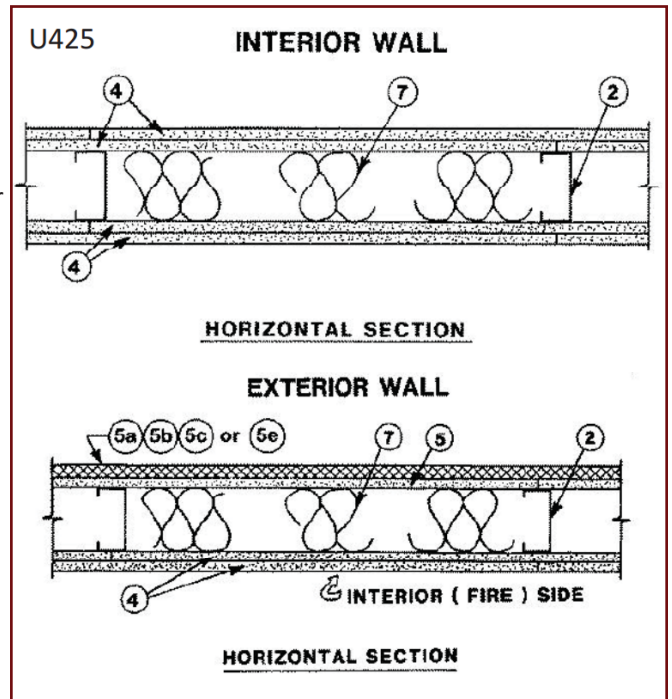

Sound Transmission Ratings

The Gypsum Association maintains details to obtain fire resistance and Sound Transmission Class (STC) Ratings. These details are designated by a Wall and Partition (WP) System. Each detail is outlined in the Gypsum Association Fire Resistance Design Manual. The details mentioned below were obtained from the 24th Edition - 2024 publication. For additional information on Gypsum Association or to acquire a copy of the Manual, visit www.gypsum.org.

A complete listing of all WP details is not shown; TSN has attempted to list only the generic details unless no generic details were available for a specific application.

Load Bearing WP Details

- WP 1015.2 - 1 hr (55-59 STC)*
 - WP 1025 - 1 hr (50-54 STC)*
 - WP 1090 - 1 hr (45-49 STC)*
 - WP 1212 - 1 hr (40-44 STC)*
 - WP 1351 - 1 hr (No STC)
 - WP 1430 - 1 hr (No STC)
 - WP 1526 - 2 hr (55-59 STC)*
 - WP 1549 - 2 hr (50-54 STC)*
 - WP 1953 - 2 hr (No STC)
 - WP 1968 - 2 hr (No STC)
- * Proprietary System

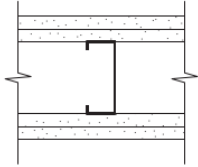
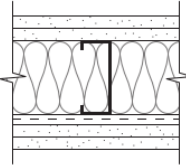
GYPSUM PANELS, STEEL STUDS	
<p>Fire Design: Base layer 5/8" proprietary type X gypsum panels applied parallel or at right angles to each side of 3-1/2", 33 mil steel studs 24" o.c. with 1" Type S-12 screws 16" o.c. Face layer 5/8" proprietary type X gypsum panels applied parallel or at right angles to each side with 1-5/8" Type S-12 screws 16" o.c. Face layer screws offset 8" from base layer screws.</p> <p>Vertical joints centered over studs and staggered one stud cavity on opposite sides and between adjacent layers. Horizontal joints staggered minimum 12" on opposite sides and between adjacent layers. Refer to design listing for load condition details. (LOAD-BEARING)</p> <p>Sound Design: Sound tested with 3-5/8", 54 mil steel studs 16" o.c., resilient channels 24" o.c., and 3-1/2" glass fiber insulation.</p> <p>PROPRIETARY GYPSUM PANELS</p>	<div style="display: flex; justify-content: space-around;">   </div> <p>Thickness: 6" (Fire) 6-5/8" (Sound)</p> <p>Approx. Weight: 9.2 psf (Fire) 9.6 psf (Sound)</p> <p>Fire Test: UL R1319, 96NK11081, 06-19-96, UL Design U423</p> <p>Sound Test: RAL TL23-243, 07-18-23</p>

SigmaStud® Punchouts

Each SigmaStud contains punchouts which are 1.5" wide and 4" tall, spaced every 24" o.c. vertically. The first punchout begins 12" o.c. from the end of the stud.

Custom punchout spacing is available upon request. Some restrictions apply.

Reinforcing Non-Standard Holes in SigmaStud®

Any larger holes cut into SigmaStud® require a review by the engineer, as load capacity is based on the existence of standard punchout sizes. With the realization that additional holes do manage to appear in studs, TSN provides the SigmaStud (SG) Web RFT to provide reinforcement of a hole or holes added to the stud web during construction, when holes larger than the standard knockout are introduced into the web of the member. Use of the SG Web RFT ensures that the load capacity of the stud is not compromised when these types of oversized holes are present.

- No loss of stud strength when using the SigmaStud Web RFT with up to a 3" hole.
- Each SigmaStud Web RFT contains 12 pre-drilled guide holes in the center section and 12 in the outside flanges, 6 per side, to ensure proper placement of the (24) #12 self-drilling self-tapping screws required.
- All modifications to SigmaStud must be reviewed by a structural engineer.
- Contact TSN's Project Management Team at (888) 474-4876 for more recommendations.
- Non standard holes may not exceed half of stud depth.

3" Maximum Hole Diameter

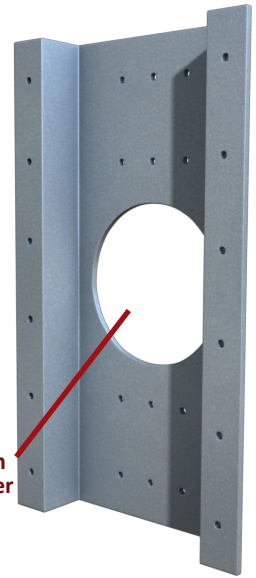

Nomenclature

SigmaStud® Web RFT is available in 54 or 97 mil thicknesses, and is designed for use with 550 & greater sized SigmaStud.

Designate: SG Web RFT-54 or SG Web RFT-97

** Use SG Web RFT-54 for SigmaStud 54mil and lower. Use SG Web RFT-97 for SigmaStud 68mil and higher.*

Material Properties:

ASTM A1003/A1003M Structural Grade 50 (340) Type H, ST50H (ST340H): 50ksi (340MPa) minimum yield strength, 65ksi (450MPa) minimum tensile strength with ASTM A653/A653M G60 (Z180) hot dipped galvanized coating.



SigmaStud®: Important Design Considerations

Wall In-Line Framing

Building loads must transfer from the vertical element above (e.g. SigmaStud® wall) to the horizontal element (e.g. Floor System), and to the vertical bearing element below (e.g. SigmaStud wall). To achieve this load transfer, the wall framing must align vertically.

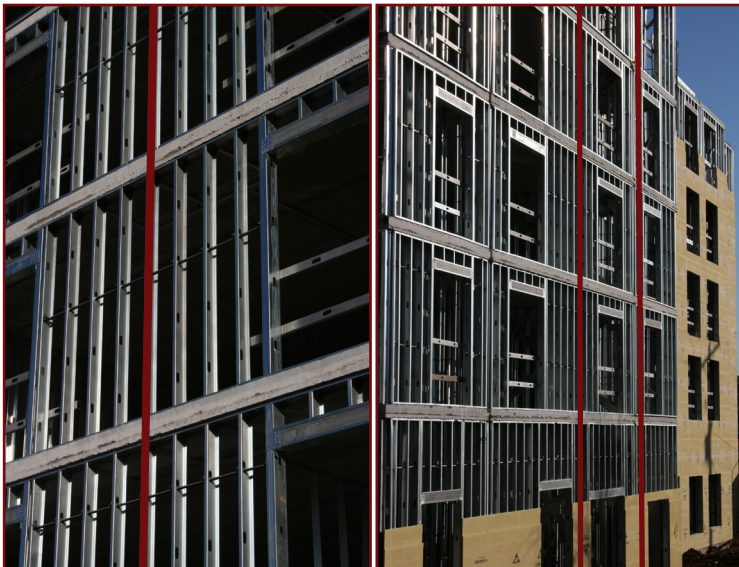

Example of framing aligned vertically. The red lines trace the axial load vertically from the roof to the foundation.

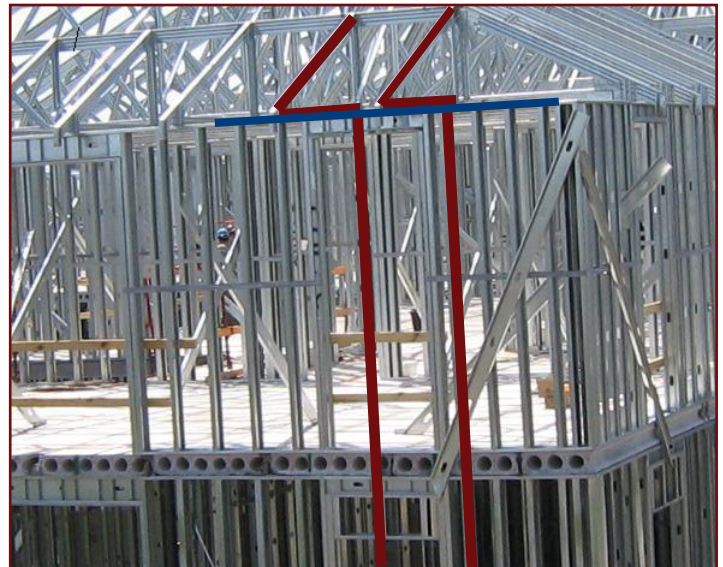

Trusses bearing on the studs, which are aligned vertically to the foundation (red lines). When truss spacing differs from stud spacing, a distribution lintel is required to transfer the load from the truss to the studs below (blue line).

600SGT150-43, 50ksi



Product Description

SigmaTrak® is the ideal runner track for load bearing and curtain wall metal stud wall assemblies. Manufactured from mill-certified steel, SigmaTrak's unique shape is designed to allow a stud to seat fully within the track, providing full bearing at the top and bottom structural tracks. Load bearing studs must be fully seated within the top and bottom tracks according to design standards.

SigmaTrak eliminates field issues typically seen with (T) section tracks where the studs bear directly on the corner radius of the track, creating gaps between the stud and track.

Benefits That Add Value:

- Track web is oversized to allow the stud to seat fully in the track
- Eliminates the gap between the stud and the track as a result of bearing on corner radii
- Faster assembly than with standard track (no forcing/squeezing stud into bearing on track radii)
- Manufactured from traceable mill-certified steel

Load Bearing Framing Track Recommendations:

- The top and bottom track should match the stud thickness
- Minimum track thickness = 43mil
- When welding is required to the top track, it is recommended to use a 14ga (68mils) thickness. Welding may be used as a means of attaching light gauge components, and should be performed by an AWS certified welder.

Material Properties:

ASTM A1003/A1003M Structural Grade 50 (340) Type H, ST50H (ST340H): 50ksi (340MPa) minimum yield strength, 65ksi (450MPa) minimum tensile strength or Structural Grade 33 (230) Type H, ST33H (ST230H): 33ksi (230MPa) minimum yield strength, 45ksi (340MPa) minimum tensile strength with ASTM A653/A653M G60 (Z180) hot dipped galvanized coating.

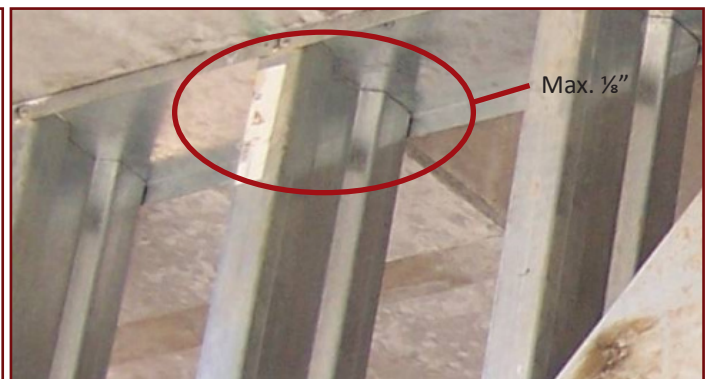
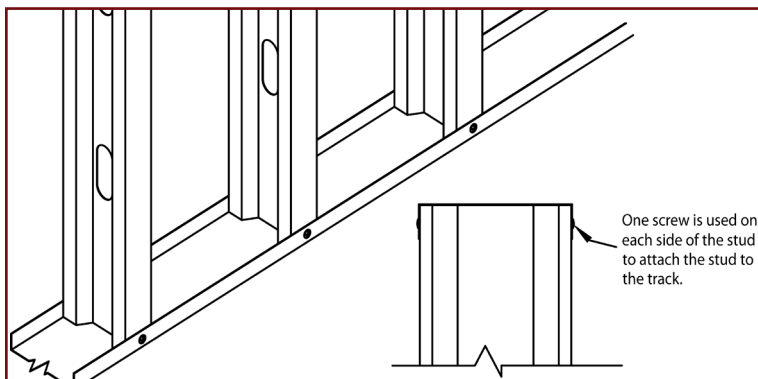
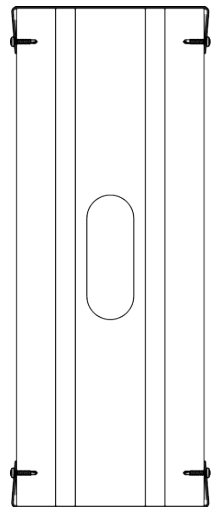

Load bearing walls are designed to fully seat within the top and bottom tracks. Design standards recommend a maximum gap of $\frac{1}{8}$ " in order to obtain an effective bearing condition.

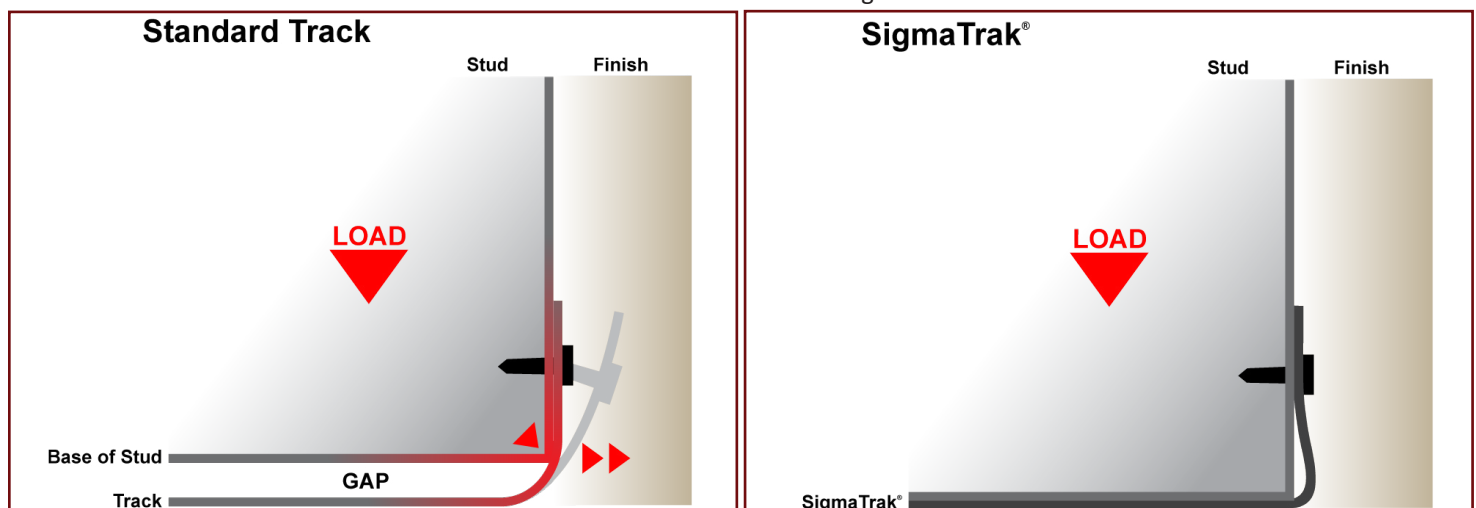

Standard track (T) sections (above left) can contain an inside corner radius that prevents "full" bearing within the track. SigmaTrak® (above right) allows full bearing of the stud within the track

Important Notes:

1. Web depth for track sections is equal to the nominal height plus 2 times the design thickness plus 2 times the bend radius.
2. Effective properties incorporate the strength increase from the cold-work of forming as applicable per AISI S100-16 Spec, Sec. A3.3.2 (3).
3. For deflection calculations, use the effective moment of inertia.
4. The effective moment of inertia for deflection is calculated at a stress which results in a section modulus such that the stress times the section modulus at that stress is equal to the allowable moment. AISI S100-16 Procedure I for Serviceability Determination has been used.

SigmaTrak® Section Properties

Section (All 50 ksi)	Design Thickness	Gross Properties							Effective Properties				Torsional Properties					
		Area	Weight	I _x	S _x	R _x	I _y	R _y	I _{xe}	S _{xe}	M _a	V _{ag}	Jx1000	C _w	X _o	m	R _o	β
		(in ²)	(lb/ft)	(in ⁴)	(in ³)	(in)	(in ⁴)	(in)	(in ⁴)	(in ³)	(in-k)	(lb)	(in ⁴)	(in ⁶)	(in)	(in)	(in)	
350SGT150-33	0.0346	0.229	0.778	0.498	0.264	1.476	0.050	0.467	0.409	0.172	5.158	1,053	0.091	0.120	-0.867	0.533	1.774	0.761
350SGT150-43	0.0451	0.298	1.013	0.651	0.343	1.479	0.064	0.465	0.566	0.243	7.263	2,141	0.202	0.156	-0.862	0.531	1.774	0.764
350SGT150-54	0.0566	0.373	1.270	0.819	0.429	1.482	0.080	0.463	0.747	0.327	9.804	3,372	0.399	0.194	-0.857	0.528	1.773	0.766
350SGT150-68	0.0713	0.470	1.599	1.036	0.538	1.485	0.099	0.460	0.988	0.446	13.355	4,679	0.796	0.243	-0.851	0.525	1.772	0.770
350SGT150-97	0.1017	0.669	2.276	1.489	0.761	1.492	0.138	0.454	1.489	0.717	21.457	6,674	2.306	0.342	-0.838	0.518	1.771	0.776
350SGT150-118	0.124	0.814	2.771	1.825	0.922	1.497	0.165	0.450	1.825	0.922	27.617	8,138	4.173	0.412	-0.828	0.513	1.769	0.781
350SGT200-33	0.0346	0.263	0.895	0.619	0.328	1.534	0.109	0.645	0.470	0.172	5.144	1,053	0.105	0.262	-1.285	0.768	2.102	0.627
350SGT200-43	0.0451	0.343	1.166	0.810	0.426	1.537	0.142	0.643	0.649	0.256	7.674	2,141	0.232	0.341	-1.280	0.765	2.101	0.629
350SGT200-54	0.0566	0.430	1.463	1.020	0.534	1.540	0.176	0.641	0.862	0.348	10.412	3,372	0.459	0.427	-1.275	0.762	2.100	0.631
350SGT200-68	0.0713	0.541	1.841	1.291	0.670	1.545	0.220	0.638	1.151	0.478	14.297	4,679	0.917	0.536	-1.268	0.759	2.098	0.635
350SGT200-97	0.1017	0.770	2.622	1.858	0.950	1.553	0.308	0.632	1.788	0.784	23.474	6,674	2.656	0.758	-1.254	0.752	2.094	0.642
350SGT200-118	0.124	0.938	3.193	2.281	1.153	1.559	0.370	0.628	2.277	1.033	30.936	8,138	4.809	0.920	-1.243	0.746	2.091	0.646
362SGT150-33	0.0346	0.233	0.792	0.537	0.275	1.519	0.050	0.465	0.442	0.181	5.424	1,017	0.093	0.130	-0.855	0.528	1.804	0.775
362SGT150-43	0.0451	0.303	1.032	0.702	0.358	1.521	0.065	0.463	0.611	0.255	7.625	2,141	0.206	0.168	-0.851	0.526	1.803	0.778
362SGT150-54	0.0566	0.380	1.294	0.884	0.448	1.524	0.081	0.461	0.806	0.343	10.279	3,372	0.406	0.210	-0.846	0.523	1.803	0.780
362SGT150-68	0.0713	0.479	1.629	1.117	0.562	1.528	0.100	0.458	1.066	0.467	13.983	4,846	0.811	0.263	-0.840	0.520	1.802	0.783
362SGT150-97	0.1017	0.681	2.319	1.605	0.795	1.535	0.139	0.452	1.605	0.749	22.424	6,912	2.349	0.369	-0.827	0.513	1.801	0.789
362SGT150-118	0.124	0.830	2.824	1.967	0.963	1.540	0.166	0.448	1.967	0.963	28.844	8,428	4.252	0.444	-0.817	0.508	1.800	0.794
362SGT200-33	0.0346	0.267	0.910	0.667	0.342	1.579	0.111	0.643	0.508	0.178	5.321	1,017	0.107	0.283	-1.270	0.761	2.126	0.643
362SGT200-43	0.0451	0.348	1.186	0.872	0.444	1.582	0.143	0.641	0.699	0.269	8.057	2,141	0.236	0.368	-1.266	0.759	2.125	0.645
362SGT200-54	0.0566	0.437	1.487	1.098	0.556	1.585	0.178	0.639	0.929	0.365	10.915	3,372	0.467	0.461	-1.260	0.756	2.123	0.648
362SGT200-68	0.0713	0.550	1.872	1.389	0.698	1.589	0.222	0.636	1.239	0.500	14.966	4,846	0.932	0.578	-1.253	0.753	2.122	0.651
362SGT200-97	0.1017	0.783	2.665	1.999	0.990	1.598	0.311	0.630	1.923	0.819	24.519	6,912	2.700	0.818	-1.239	0.746	2.118	0.658
362SGT200-118	0.124	0.954	3.246	2.453	1.201	1.604	0.374	0.626	2.448	1.078	32.279	8,428	4.888	0.992	-1.229	0.740	2.115	0.662
400SGT150-33	0.0346	0.246	0.837	0.666	0.311	1.646	0.052	0.458	0.554	0.198	5.932	922	0.098	0.161	-0.823	0.513	1.896	0.812
400SGT150-43	0.0451	0.320	1.090	0.870	0.405	1.648	0.067	0.456	0.759	0.292	8.756	2,041	0.217	0.209	-0.818	0.511	1.896	0.814
400SGT150-54	0.0566	0.402	1.367	1.094	0.506	1.651	0.083	0.454	0.999	0.393	11.759	3,372	0.429	0.261	-0.814	0.508	1.896	0.816
400SGT150-68	0.0713	0.505	1.720	1.383	0.635	1.654	0.103	0.451	1.320	0.532	15.936	5,348	0.856	0.326	-0.807	0.505	1.895	0.818
400SGT150-97	0.1017	0.720	2.449	1.984	0.899	1.661	0.143	0.445	1.984	0.849	25.422	7,628	2.481	0.458	-0.795	0.498	1.894	0.824
400SGT150-118	0.124	0.876	2.982	2.430	1.090	1.665	0.171	0.441	2.430	1.090	32.639	9,300	4.491	0.551	-0.786	0.493	1.894	0.828
400SGT200-33	0.0346	0.280	0.954	0.822	0.384	1.712	0.114	0.637	0.634	0.195	5.849	922	0.112	0.352	-1.229	0.744	2.201	0.688
400SGT200-43	0.0451	0.365	1.243	1.074	0.500	1.715	0.147	0.635	0.866	0.309	9.251	2,041	0.248	0.457	-1.224	0.741	2.200	0.690
400SGT200-54	0.0566	0.458	1.559	1.352	0.625	1.718	0.183	0.633	1.147	0.417	12.483	3,372	0.489	0.572	-1.219	0.739	2.199	0.693
400SGT200-68	0.0713	0.577	1.963	1.709	0.785	1.722	0.229	0.630	1.527	0.569	17.044	5,348	0.977	0.717	-1.212	0.735	2.198	0.696
400SGT200-97	0.1017	0.821	2.795	2.457	1.113	1.730	0.320	0.624	2.364	0.927	27.754	7,628	2.832	1.014	-1.199	0.728	2.195	0.702
400SGT200-118	0.124	1.000	3.404	3.012	1.351	1.735	0.384	0.620	3.005	1.217	36.426	9,300	5.126	1.228	-1.189	0.723	2.193	0.706

Refer to Important Table Notes on Page 43

SigmaTrak® Section Properties																		
Section (All 50 ksi)	Design Thickness	Gross Properties							Effective Properties				Torsional Properties					
		Area	Weight	I _x	S _x	R _x	I _y	R _y	I _{xe}	S _{xe}	M _a	V _{ag}	Jx1000	C _w	X _o	m	R _o	β
		(in)	(in ²)	(lb/ft)	(in ⁴)	(in ³)	(in)	(in ⁴)	(in)	(in ⁴)	(in ³)	(in-k)	(lb)	(in ⁴)	(in ⁶)	(in)	(in)	
550SGT150-33	0.0346	0.298	1.013	1.363	0.472	2.139	0.056	0.433	1.175	0.265	7.940	670	0.119	0.330	-0.715	0.460	2.297	0.903
550SGT150-43	0.0451	0.388	1.320	1.778	0.613	2.141	0.072	0.431	1.576	0.451	13.491	1,484	0.263	0.427	-0.711	0.457	2.297	0.904
550SGT150-54	0.0566	0.486	1.656	2.235	0.767	2.143	0.089	0.428	2.055	0.618	18.491	2,934	0.519	0.532	-0.707	0.455	2.297	0.905
550SGT150-68	0.0713	0.612	2.084	2.820	0.964	2.146	0.111	0.426	2.699	0.827	24.765	5,350	1.038	0.664	-0.702	0.452	2.297	0.907
550SGT150-97	0.1017	0.872	2.968	4.035	1.365	2.151	0.154	0.420	4.035	1.298	38.851	10,488	3.007	0.929	-0.691	0.445	2.298	0.910
550SGT150-118	0.124	1.062	3.615	4.932	1.655	2.155	0.184	0.416	4.932	1.655	49.564	12,788	5.444	1.116	-0.683	0.441	2.298	0.912
550SGT200-33	0.0346	0.332	1.131	1.648	0.570	2.227	0.124	0.611	1.323	0.266	7.955	670	0.133	0.717	-1.089	0.680	2.553	0.818
550SGT200-43	0.0451	0.433	1.473	2.152	0.742	2.229	0.161	0.609	1.783	0.445	13.324	1,484	0.294	0.931	-1.085	0.677	2.553	0.819
550SGT200-54	0.0566	0.543	1.848	2.705	0.929	2.232	0.200	0.607	2.321	0.654	19.589	2,934	0.580	1.163	-1.080	0.675	2.553	0.821
550SGT200-68	0.0713	0.684	2.327	3.415	1.167	2.235	0.249	0.604	3.071	0.882	26.403	5,350	1.159	1.457	-1.074	0.672	2.552	0.823
550SGT200-97	0.1017	0.974	3.314	4.894	1.655	2.242	0.349	0.598	4.713	1.408	42.161	10,488	3.357	2.053	-1.062	0.665	2.552	0.827
550SGT200-118	0.124	1.186	4.037	5.987	2.010	2.247	0.418	0.594	5.963	1.830	54.787	12,788	6.080	2.481	-1.053	0.660	2.551	0.830
600SGT150-33	0.0346	0.315	1.072	1.666	0.531	2.300	0.057	0.425	1.391	0.273	8.187	614	0.126	0.401	-0.686	0.444	2.437	0.921
600SGT150-43	0.0451	0.410	1.397	2.174	0.690	2.302	0.073	0.423	1.936	0.431	12.915	1,361	0.278	0.519	-0.682	0.442	2.438	0.922
600SGT150-54	0.0566	0.515	1.752	2.732	0.864	2.304	0.091	0.420	2.543	0.630	18.872	2,690	0.550	0.647	-0.678	0.440	2.438	0.923
600SGT150-68	0.0713	0.648	2.205	3.446	1.085	2.306	0.113	0.418	3.310	0.911	27.263	5,350	1.098	0.807	-0.673	0.437	2.438	0.924
600SGT150-97	0.1017	0.923	3.141	4.928	1.537	2.311	0.157	0.412	4.928	1.464	43.837	10,885	3.182	1.128	-0.662	0.430	2.439	0.926
600SGT150-118	0.124	1.124	3.826	6.021	1.865	2.314	0.187	0.408	6.021	1.865	55.825	13,950	5.762	1.355	-0.654	0.426	2.439	0.928
600SGT200-33	0.0346	0.350	1.190	2.004	0.638	2.394	0.127	0.602	1.626	0.289	8.659	614	0.140	0.872	-1.050	0.661	2.683	0.847
600SGT200-43	0.0451	0.456	1.550	2.615	0.830	2.396	0.164	0.600	2.190	0.482	14.434	1,361	0.309	1.132	-1.046	0.658	2.682	0.848
600SGT200-54	0.0566	0.571	1.944	3.287	1.040	2.399	0.204	0.598	2.831	0.743	22.252	2,690	0.610	1.415	-1.041	0.656	2.682	0.849
600SGT200-68	0.0713	0.719	2.448	4.149	1.306	2.402	0.255	0.595	3.739	0.998	29.890	5,350	1.219	1.771	-1.035	0.653	2.682	0.851
600SGT200-97	0.1017	1.025	3.487	5.941	1.853	2.408	0.356	0.590	5.724	1.586	47.481	10,885	3.533	2.495	-1.023	0.646	2.682	0.854
600SGT200-118	0.124	1.248	4.248	7.264	2.250	2.412	0.428	0.585	7.234	2.055	61.535	13,950	6.397	3.013	-1.015	0.641	2.682	0.857
800SGT150-33 ¹	0.0346	0.384	1.308	3.297	0.796	2.929	0.060	0.396	2.690	0.369	11.050	461	0.153	0.768	-0.590	0.392	3.014	0.962
800SGT150-43	0.0451	0.501	1.704	4.299	1.036	2.931	0.078	0.394	3.762	0.587	17.589	1,021	0.339	0.994	-0.586	0.390	3.014	0.962
800SGT150-54	0.0566	0.628	2.137	5.398	1.297	2.932	0.096	0.392	4.985	0.868	25.994	2,017	0.671	1.237	-0.583	0.387	3.015	0.963
800SGT150-68	0.0713	0.791	2.691	6.805	1.629	2.934	0.120	0.389	6.596	1.275	38.163	4,033	1.340	1.542	-0.578	0.385	3.015	0.963
800SGT150-97	0.1017	1.126	3.833	9.718	2.310	2.937	0.166	0.384	9.718	2.205	66.007	10,885	3.883	2.150	-0.569	0.379	3.016	0.964
800SGT150-118	0.124	1.372	4.670	11.860	2.804	2.940	0.198	0.380	11.860	2.804	83.964	16,182	7.033	2.578	-0.562	0.375	3.017	0.965
800SGT200-33 ¹	0.0346	0.419	1.425	3.885	0.938	3.046	0.136	0.569	2.987	0.376	11.269	461	0.167	1.676	-0.919	0.594	3.232	0.919
800SGT200-43	0.0451	0.546	1.857	5.068	1.221	3.047	0.175	0.567	4.188	0.603	18.044	1,021	0.370	2.173	-0.916	0.592	3.232	0.920
800SGT200-54	0.0566	0.685	2.330	6.365	1.530	3.049	0.218	0.565	5.566	0.897	26.856	2,017	0.731	2.713	-0.911	0.590	3.232	0.920
800SGT200-68	0.0713	0.862	2.933	8.027	1.922	3.052	0.272	0.562	7.388	1.330	39.816	4,033	1.461	3.394	-0.906	0.587	3.233	0.921
800SGT200-97	0.1017	1.228	4.179	11.475	2.728	3.057	0.380	0.556	11.090	2.352	70.425	10,885	4.234	4.770	-0.895	0.581	3.233	0.923
800SGT200-118	0.124	1.496	5.092	14.013	3.314	3.060	0.456	0.552	13.944	3.061	91.645	16,182	7.669	5.753	-0.888	0.576	3.234	0.925

¹ Web-height to thickness ratio exceeds 200. Web stiffeners are required at all support points and concentrated loads.

Load Bearing Wall Members

Design Assist Services

Redefining Design Assist

The Steel Network identifies design assist opportunities when framing with Cold-Formed Steel (CFS) systems. CFS is proven to reduce overall costs and accelerate construction schedules while meeting building code requirements.

- Lower overall project costs
- Material cost savings in the wall system
- Reduced foundation requirements and cost
- Accelerated construction schedules
- Fewer subcontractors on the job
- Satisfied Developers, Contractors, Structural Engineers and Architects



What does TSN's Design Assist Service Provide?

- 1. Partnership:** TSN will partner with the project team to recommend the best solutions to fit project conditions. Our services apply at any point in the project; from the Architect, Engineer of Record, General Contractor, Sub-Contractor, Specialty Engineer (Shop Drawer), to the Distributor. Each member of the team can partner with TSN to determine the best course of action for the project.
- 2. Budgeting/Cost Certainty:** TSN's expertise may enable over-budgeted projects to meet budget, and may also provide substantial savings to projects already within a posted budget. TSN's DA services have provided significant savings in the wall system as well as in the secondary systems, such as foundations.
- 3. Flexibility:** The project design team is empowered to determine the best foundation, floor, and roof systems for the project.
- 4. Scheduling:** TSN's DA services often result in accelerated construction schedules which, in turn, save resources.

Optimizing the Structure

The Steel Network's load bearing wall systems (LBWS) create the opportunity to fully-optimize the structural systems, including walls, floors, and the building's foundation. Use of SigmaStud® (12psf) in place of the much heavier concrete/masonry block (45psf) enables the Structural Engineer to determine if a more efficient foundation, including the elimination of geo-piers is possible. "Real world" experience proves time and time again the tremendous value TSN's LBWS delivers to the construction team.

TSN's Load Bearing Wall Systems provide approximately \$2/sq.ft. of material cost savings *in addition to* the significant time/labor savings related to scheduling and installation.

Electrical Consideration

In concrete/masonry walls, electrical wires are installed on both sides of the masonry in gaps provided by some type of furring channel. This adds to the cost of concrete/masonry in the comparison above. This added expense is not seen in TSN's SigmaStud due to the pre-punched knockouts located vertically at 24" o.c.



SigmaStud's punchouts provide a convenient avenue for electrical chase.

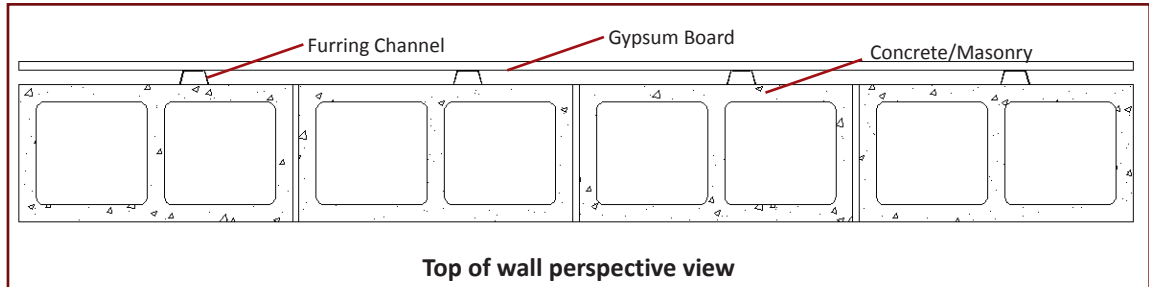

Concrete/Masonry walls require additional furring for installation of finishes and wiring.

Temporary Construction Bracing

Temporary construction bracing is necessary in order to install steel framed load bearing wall systems. Coordinate temporary bracing with the Specialty Engineer and/or the General Contractor. Safe and proper installation and “loading” of the walls can only be achieved if the adequate temporary bracing is installed. **Failure to do this can result in wall failure and/or the risk of serious injury.**

Two types of construction bracing are required:

- In the plane of the wall (may employ the X-bracing of the shear wall panels and/or by adding diagonal kickers at the two ends of the wall).
- Out of the plane of the wall.

When should temporary construction bracing be removed?

- After at least 2 floors above the temporarily braced wall are installed, allowing the walls to “seat”.
- After all permanent shear wall bracing is installed and tightened.
- After all of the perpendicular walls are connected.



Suggested Minimum Construction Bracing for Load Bearing Wall 10' or Less, Out-of-Plane

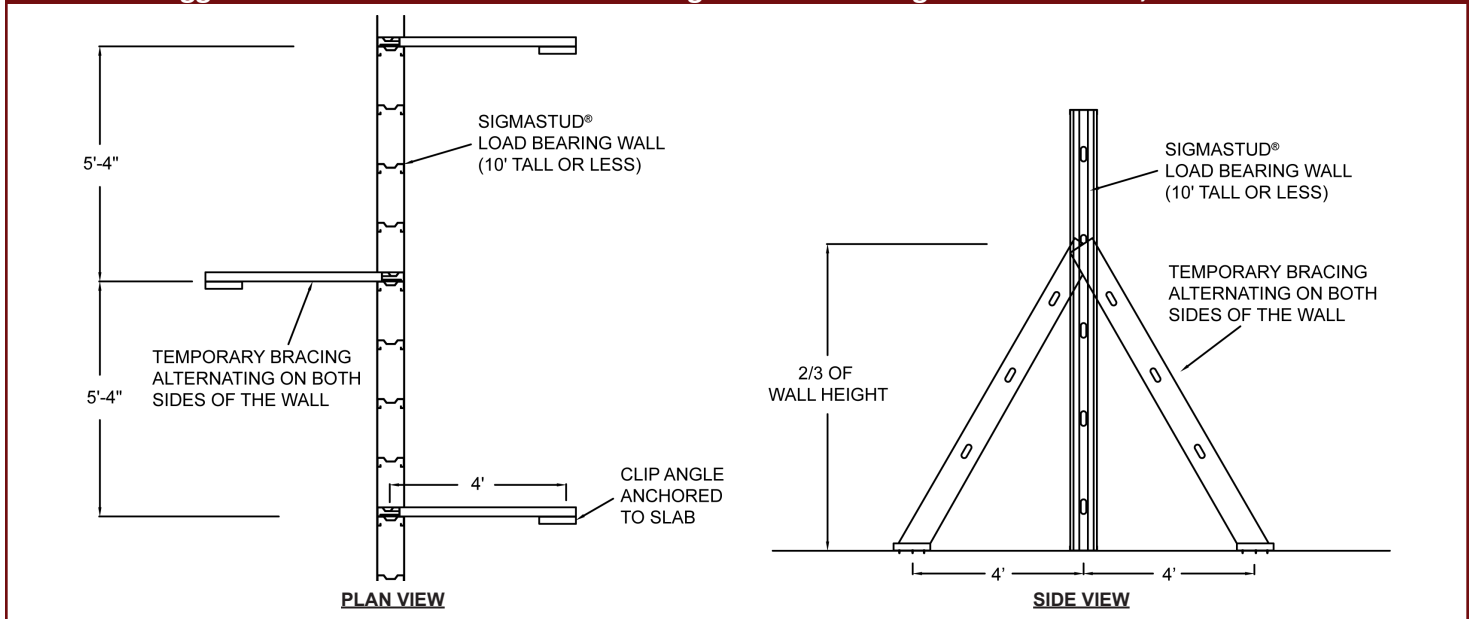

* Temporary bracing should be designed by a design professional.

Suggested Minimum Construction Bracing for Load Bearing Wall: In-Plane at Corridor

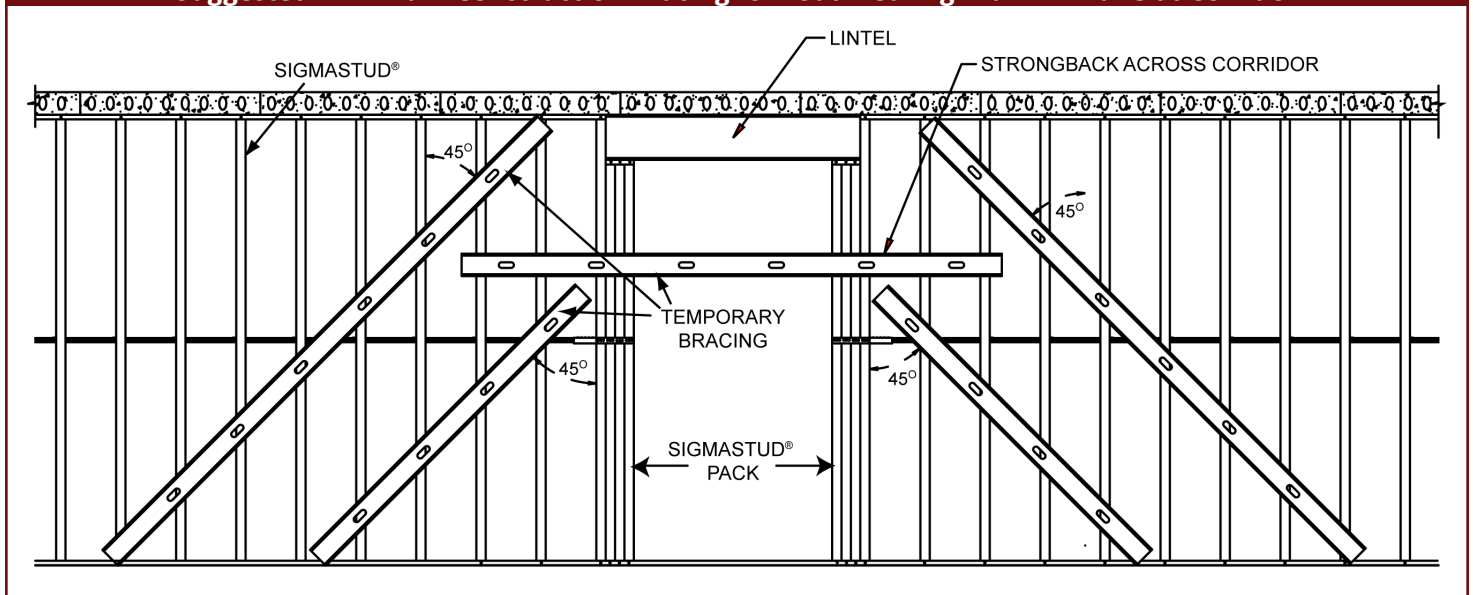

Additional temporary bracing details are available at www.steelnetwork.com

Description

TSN's *Load Bearing Wall Systems Construction Guide* provides an in-depth look into a variety of design and installation conditions concerning use of SigmaStud and StiffWall in construction projects. The purpose of the guide is to educate contractors, architects and engineers on the proper use of TSN's load bearing wall systems on the job site. The Steel Network wants to ensure that our customers fully understand these systems and are supplied with detailed information addressing installation issues, including the following:

- SigmaStud installation to the top and bottom tracks
- Track recommendations
- Shims
- Reinforcing non-standard holes in SigmaStud
- Temporary construction bracing
- Corridor framing
- Panelized walls
- Key wall bridging issues

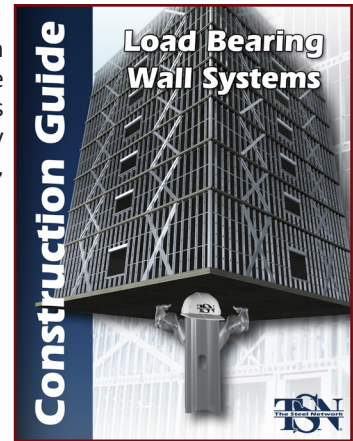

Track Reinforcement

The top and bottom wall tracks in contact with hollowcore planks need to be continuous. The contractor must provide track splicing if the tracks are cut.

- To splice track in a load-bearing wall, an extra piece of stud must be used inside the track to sufficiently overlap each side of the joint. 2-3 screws are then installed through the flanges on each side of the joint, on both sides of the track (for a total of 8-12 screws per splice).
- In adjacent walls ending with edge studs, a plate may be screwed or welded across the flanges of the end studs of two adjacent walls. In addition to this, the studs must be screwed or welded together per standard column/screw guidelines.

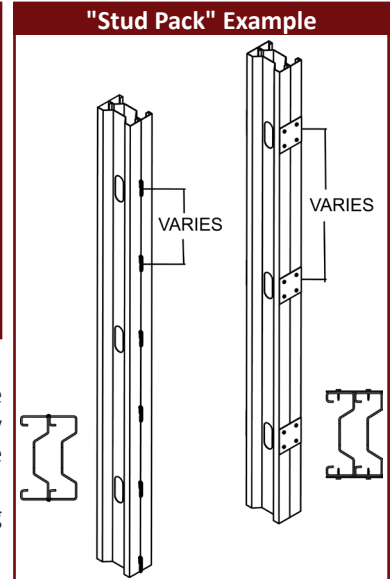
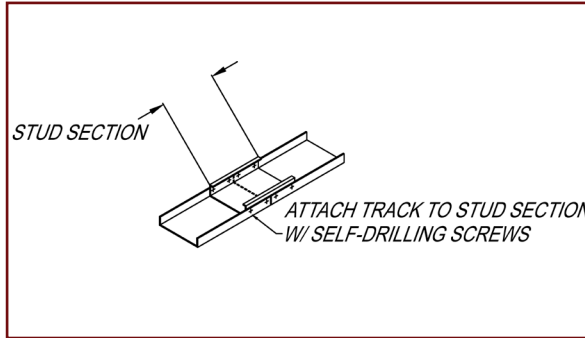

Corridor Framing

In applications where the plank spans bays that are parallel to the corridor, plank direction can be maintained in the corridor through the use of a load distribution lintel. Structural steel is commonly used to act as the lintel to support the opening, resulting in increased point loads acting on the columns. Bearing requirements for various types of structural steel vary and must be satisfied.

- Typically, multiple studs of the same thickness are used in "stud-packs" to provide bearing points for structural steel lintels.
- Coordinate the use of "stud packs" with the structural engineer.

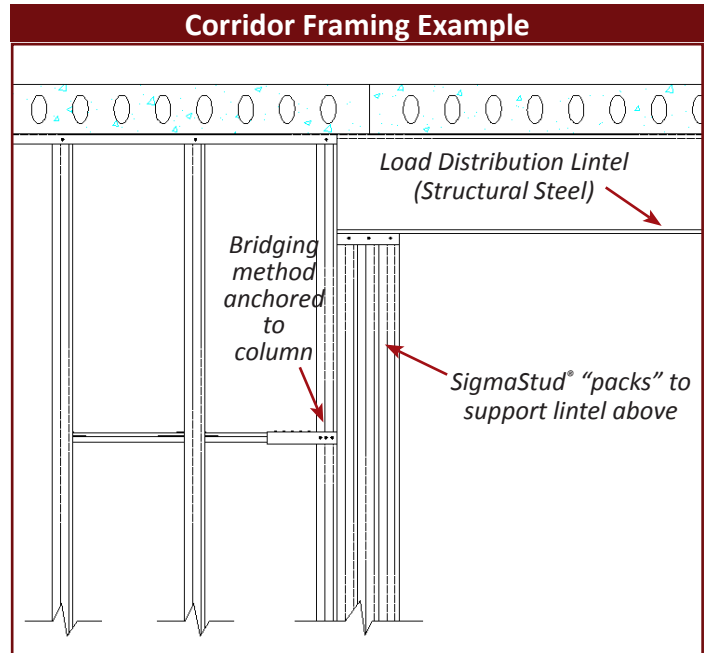
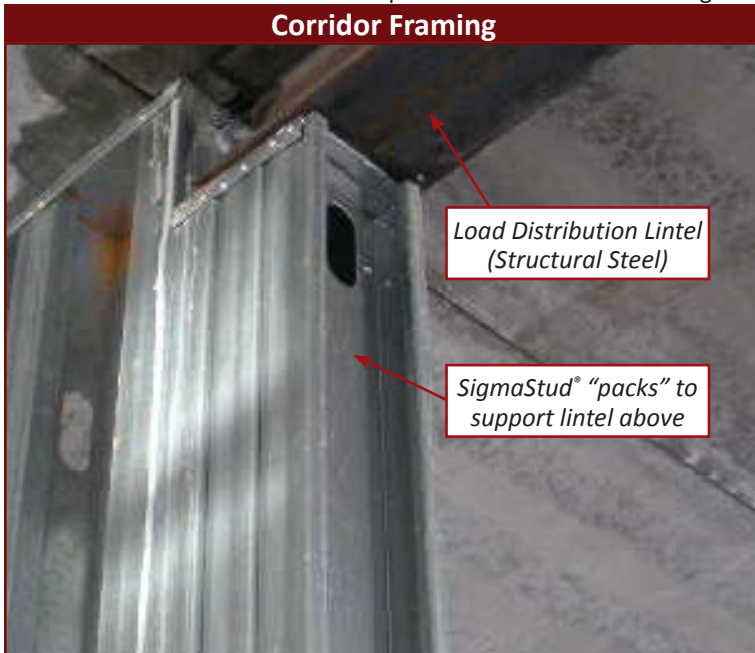

Load Bearing Wall Members

Construction Guide - Wall Studs

Embedded Plates

If the floor system consists of hollow core planks:

- Typically attach the top track to the floor above by welding the bottom of a key plate (Splice Plate) to the track.
- The key is then grouted in between the two planks, connecting the floor system to the rest of the structure.
- Embedded bolts/anchors and power actuated fasteners can also serve to connect the load bearing walls with various floor diaphragms, per the structural engineer's specifications.
- Be sure to clarify specific methods of attachment with the engineer.

Visit www.steelnetwork.com for a copy of the Construction Guide!

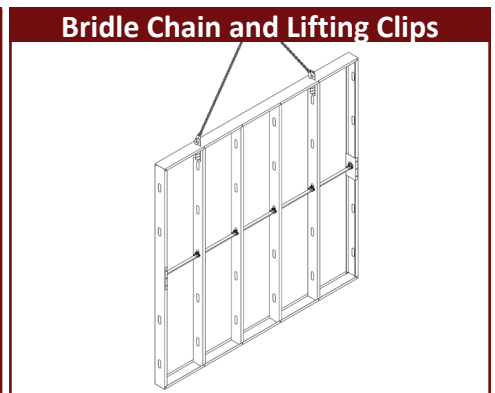
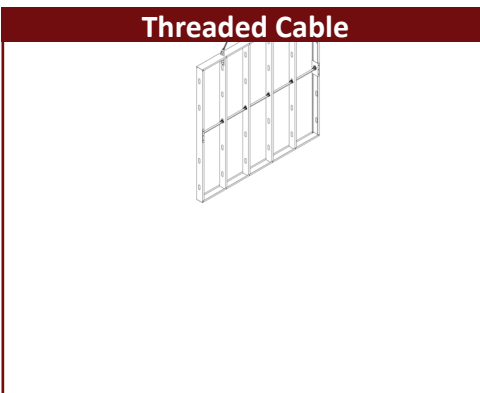
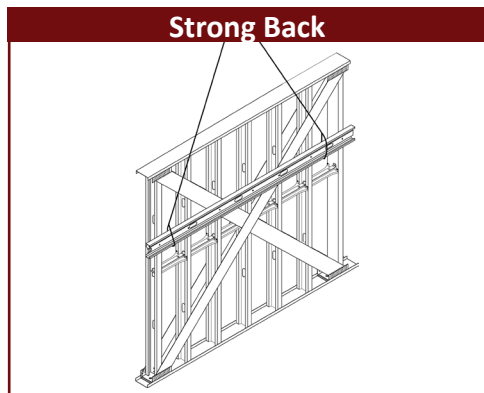
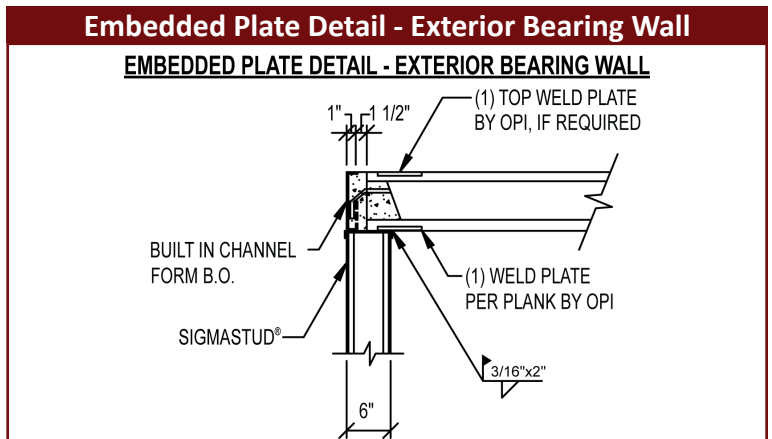
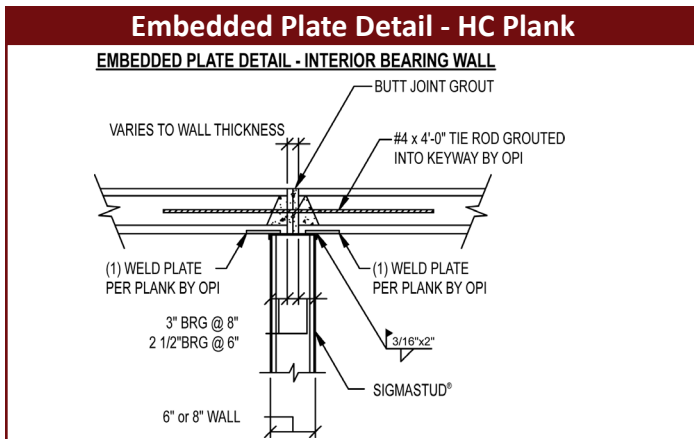
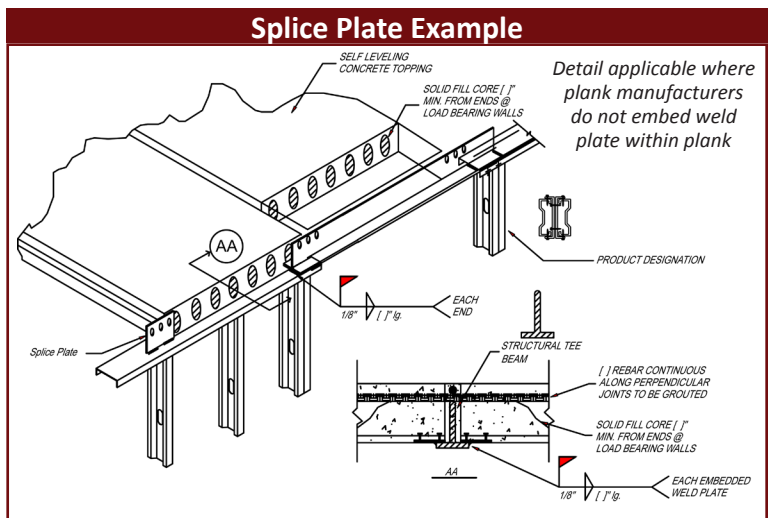

Wall Panel Lifting and Handling

When lifting wall panels into place, **avoid using the bridging components as lifting points**. This could bend or deform the bridging members, rendering them ineffective. Here are three suggestions that have worked well in existing installations:

- Attach a temporary stud or other bracing member (“strong back”) horizontally across the wall panel and use it to lift the wall sections into place.
- Thread cables through the stud punchouts at either end to lift the panel.
- Attach bridle chains to StiffClip® PLC (or other lifting clip) at lifting studs within wall panel. See manufacturers published data for lifting capacities.



Design Example

Using the requirements of Section B3.4.1.2 in the AISI S240-20 Standard for Cold-Formed Steel Structural Framing design BuckleBridge® lateral bracing system for an 8 ft. tall CFS load bearing wall. The wall consists of 800SG200-54 studs spaced at 16 inches o.c.

Solution

a) Design compression load per stud, $P = 11.5$ kips:

From SigmaStud charts, 8 ft. Wall Height, No Lateral Load:
 One row of lateral bracing, unbraced length $L_b = 48$ inches
 800SG200-54, Allowable strength $P_a = 12.04$ kips

b) Required bridging strength for a single SigmaStud:

$$P_{br,1} = 0.02(11.5 \text{ kips}) = 0.23 \text{ kips}$$

c) Check the strength of BuckleBridge:

Since the bridging row can resist lateral bracing forces either in compression or in tension, the maximum wall length that can be braced before anchorage is determined from the load capacity of BuckleBridge in compression and tension as follows:

$$\begin{aligned} \text{Maximum number of studs that can be braced in } \mathbf{compression} &= \text{BuckleBridge } P_{Comp} / P_{br,1} \\ &= 2.4 \text{ kips} / 0.23 \text{ kips} = 10 \text{ studs} \end{aligned}$$

$$\begin{aligned} \text{Maximum number of studs that can be braced in } \mathbf{tension} &= \text{BuckleBridge } P_{Tension} / P_{br,1} \\ &= 0.44 \text{ kips} / 0.23 \text{ kips} = 1 \text{ stud} \end{aligned}$$

$$\text{Maximum number of studs that can be braced before anchorage} = (10 + 1 + 1) \text{ studs} = 12 \text{ studs (see chart below)}$$

The lateral bracing needs to be anchored at rigid columns every 12 studs = 16 ft 0 in.

Use double SigmaStud® section or JamStud® section as a rigid column at anchorage locations (see anchorage details).

Design rigid columns for a lateral force = $12 \times 0.23 \text{ kips} = 2.76 \text{ kips}$

Alternatively, use cross-bracing to floor system as the anchorage method (see anchorage details).

Note: AISI S100-16 requires less capacity for the lateral bracing (bridging) row, but mandates additional stiffness requirements. Check BuckleBridge stiffness capacity.

Anchorage solution should be checked to ensure it is capable of resisting the load transferred from the bridging member.

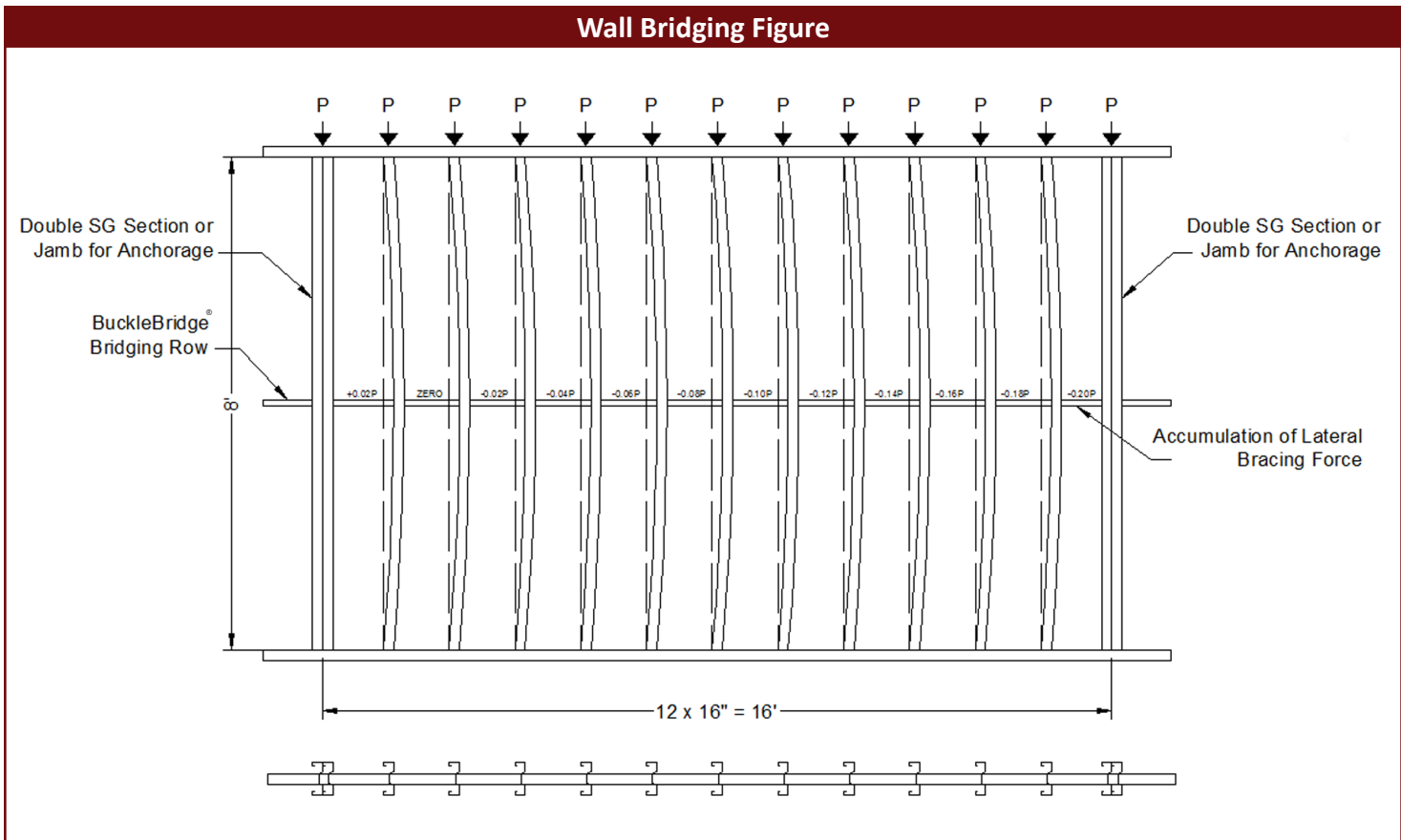

Load Bearing Wall Members

Bridging Anchorage

Anchorage of Lateral Bracing (Bridging) Forces

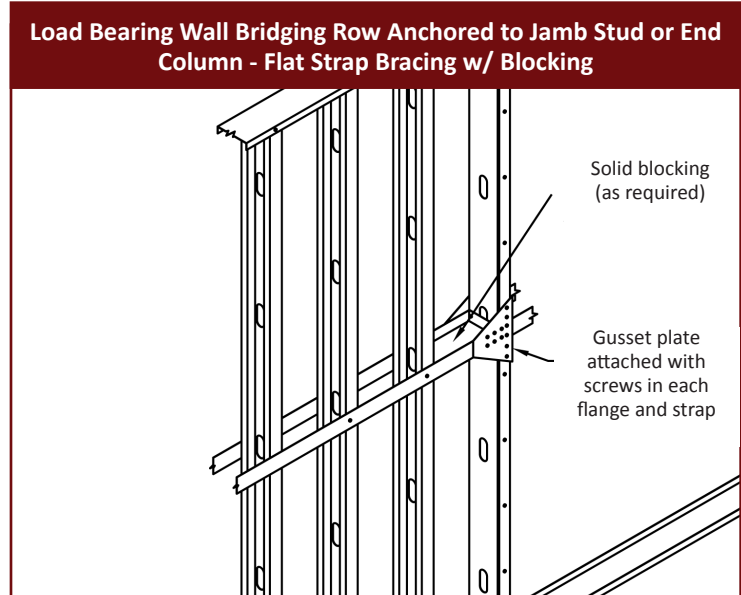
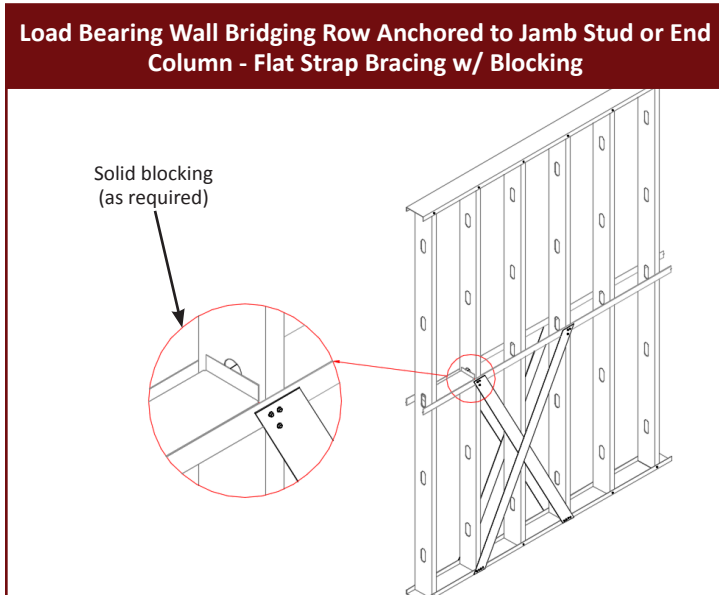
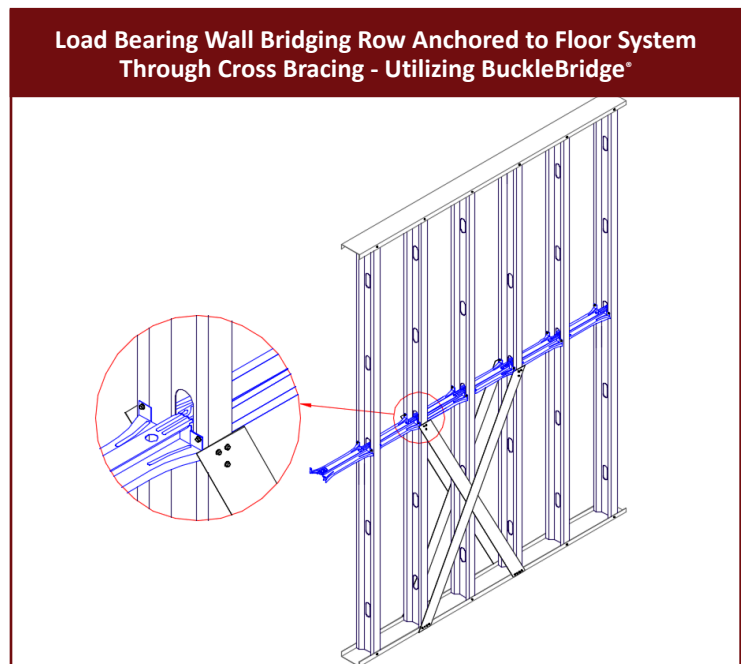
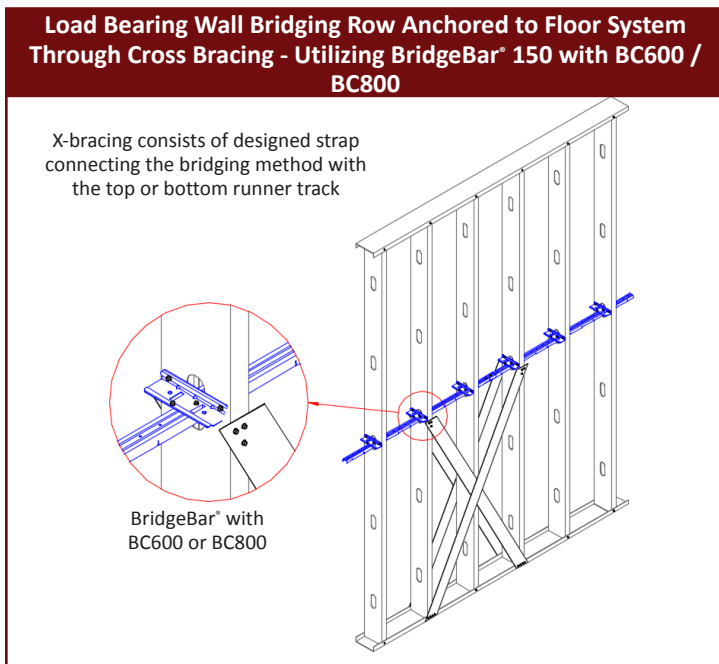
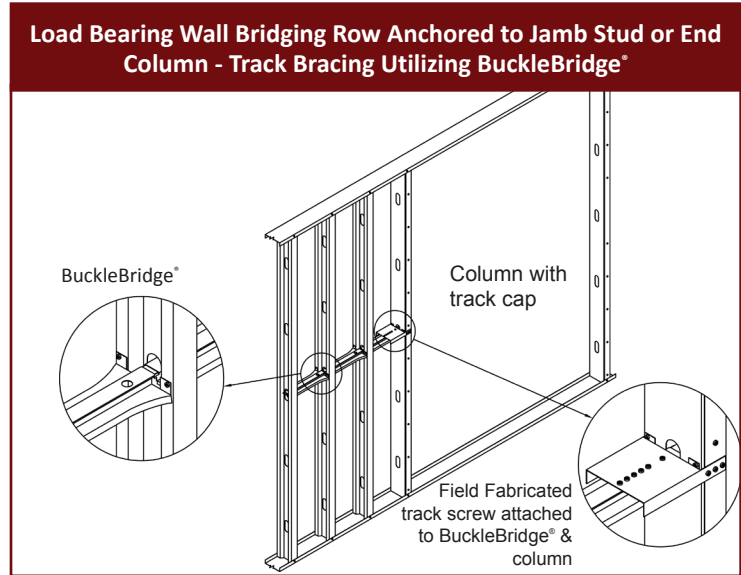
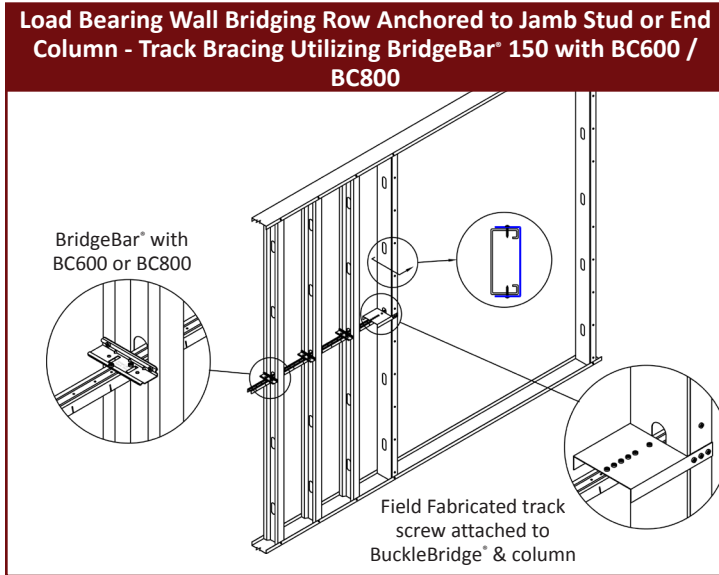

600C/STW250-68-1-SM-10ft-9-1/4"

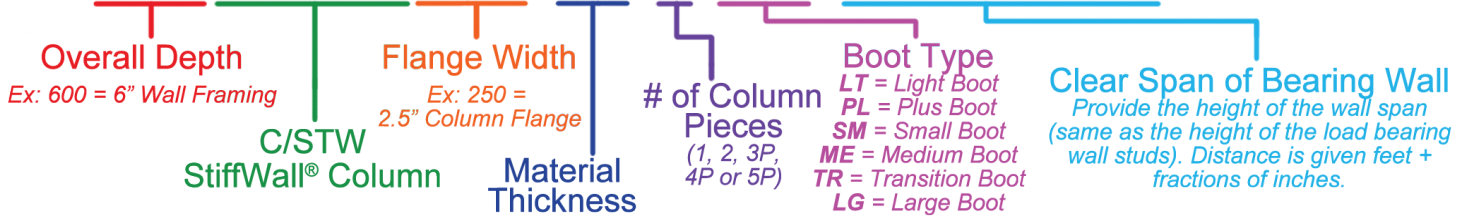

Background

StiffWall® SWS is a shear wall system designed to carry lateral loads concentrically from the point of applied loads to the foundation or other termination point, that utilizes light gage straps on both sides of the wall for shear resistance. StiffWall provides superior quality with high yield ASTM A1003 steel and hot-dipped galvanized coating for long-term durability. It is specified using simple nomenclature indicating only essential design requirements for each shear wall element. The design is ideal for job specific sizes with established load requirements. The Steel Network has optimized the design and fabrication of StiffWall through a series of both component and full scale wall assembly tests, using state of the art technology to measure performance.

StiffWall shear walls provide both lateral strength and stiffness. Lateral strength is needed to resist horizontal loads due to wind and earthquake forces. Properly designed and constructed shear walls transfer lateral forces to the next structural element in the load path below them, such as other shear walls, floors, or foundations.

Lateral stiffness is needed to prevent excessive side-sway of the structure. When shear walls are of adequate stiffness, they will maintain the lateral deflection or serviceability requirements of the building. In addition, buildings with sufficient lateral stiffness will suffer less nonstructural damage, further avoiding long-term degradation due to veneer cracking and water infiltration.

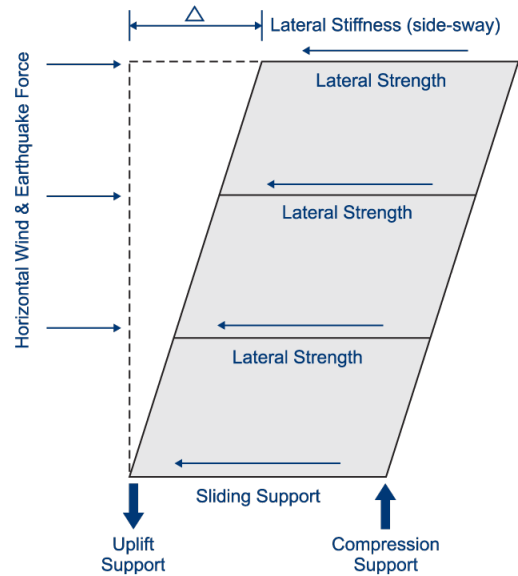

StiffWall System Components:

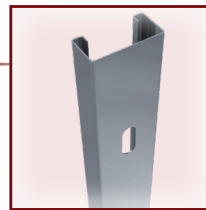
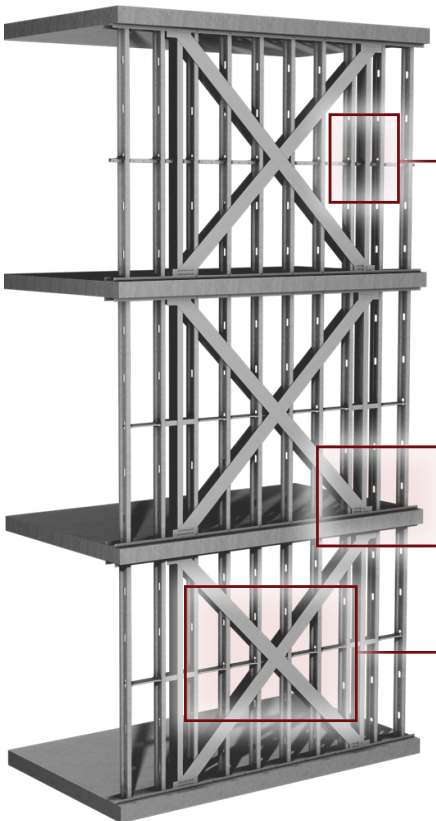

Columns (C/STW)

- End posts for the shear wall
- Wider flange and additional return lips provide an increased load capacity over standard steel stud sections

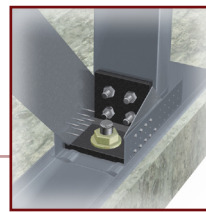

Boots

- Made up of a Strap Track (97 mil, 12" long track section with pre-punched screw pilot holes) and a Base Plate ("T" shaped structural steel), specified bolts for connection to column, and is designed to fit into a standard size track.
- Transfers the loads from the straps and columns through the floor system down to the foundation
- Pre-installed on top and bottom of each column by TSN
- Fits into a standard track (T) section

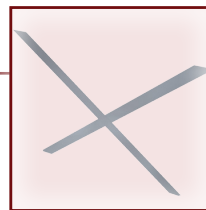

Flat Strap

- Runs diagonally (corner to corner) as a single piece and attaches to the strap track in an "X" pattern
- Four (4) pieces of flat strap are used in each StiffWall (2 pcs each side)
- Made to your specifications, always using 50 ksi steel



TightStrap®

- Device used to tension (tighten) flat strap in the field
- Removes "waviness" or "bowing" prior to fastening
- Ensures flat straps are as tight as possible when installed to achieve optimal system performance
- Fastens to standard track at the corners of the shear wall to provide a base for the tensioning process

* The infill studs are not part of the StiffWall system and act independently of the shear wall. The floor slabs are part of the lateral load resisting system, but are not part of TSN StiffWall system.

Planning Shear Walls

To develop an efficient shear wall layout several factors need to be considered:

- Height to Width aspect ratio guidelines should be observed in order to maximize effectiveness
- Shear walls should be evenly distributed across the floor plan to reduce additional lateral loads resulting from torsional effects on the floor plan
- Shear Walls located in load bearing walls may use floor dead loads with the appropriate load combination to offset uplift forces in the StiffWall
- Walls must stack vertically from top floor of structure to anchorage point or foundation
- Shear walls may overlap when the available wall space has been depleted

StiffWall® Benefits That Add Value



- Templates are not required for hold-downs, eliminating unrealistic field procedures.
- Designed and manufactured to meet the performance requirements of the project.
- Satisfies maximum story drift requirements per IBC.
- Only mill certified high strength steel is used.
- Plywood sheathing with fastener schedules and/or CMU shear walls are eliminated.
- Inspection is limited to simple connections at corners.
- Exceeds industry standards for sizes and loads.
- Versatile design may be incorporated into steel, concrete and wood construction
- Tested for multi-story application and capable of carrying loads present in 10 story buildings.
- No welds or controlled inspections associated with welding.
- Simplified anchoring system through floors and at roof termination.
- Each component is selected to meet or exceed both strength and stiffness requirements of the applicable building code.
- The strap system is on the outside of the wall to facilitate electrical and pipe work in the wall cavity.
- Allows 3 times the window space of plywood braced structures.

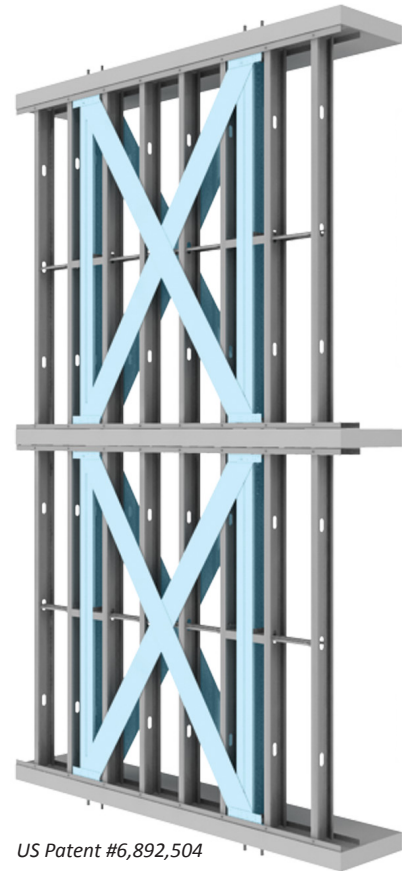

US Patent #6,892,504

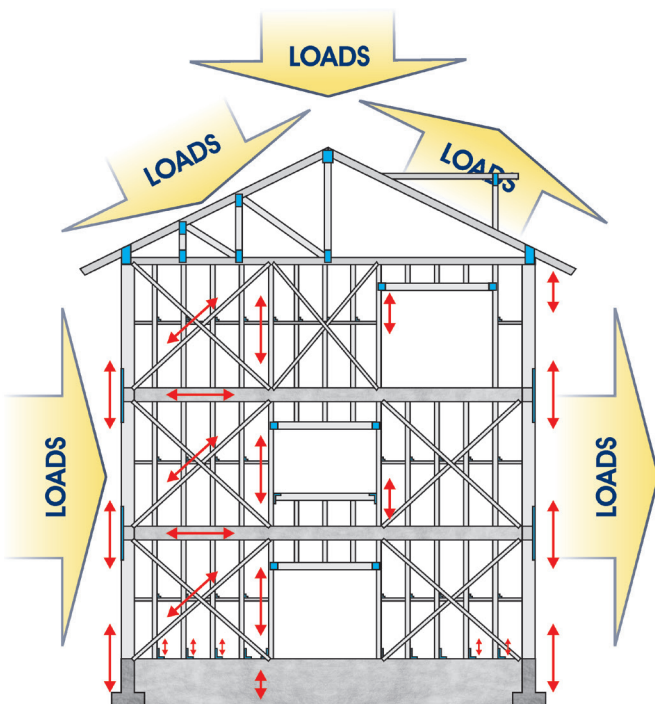

Verifying Load Paths

Tracing and verifying load paths through a structure is crucial to protect engineering liability. Loads need to migrate from the roof, through the wall and floor systems, and terminate in the foundation. Shear wall systems transfer lateral loads from the member above (i.e. floor slab) to the member below (i.e. foundation). StiffWall® provides a traceable, easily verifiable load path through the structure.

- A** Load transfers from the floor above through the floor connector, and to the StiffWall Boot
 - B** From the Boot to the Strap Track*
 - C** From the Strap Track to the flat strap*
 - D** Through the flat strap to the Strap Track at opposite corner*
 - E** From the Strap Track to the Boot
 - F** From the Boot to the floor/system or foundation below
- * The column section assumes the compression loads.
 * Uplift forces are transferred through the StiffWall Boot through full bearing onto the SWS Boot Base Plate to the anchor.

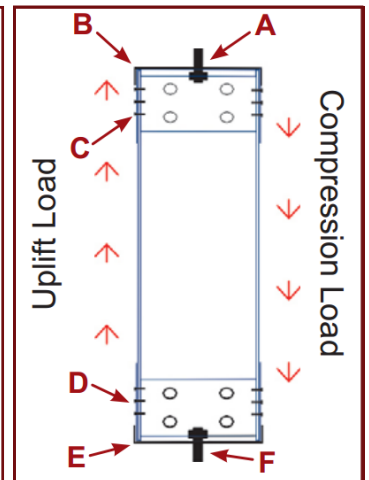

Simple Steps to Design Shear Walls

The following pages offer a guide for the design of the StiffWall® shear wall system. In addition, SteelSmart® System software is available (at www.steelSMARTsystem.com) to select the optimal column, boot, strap and fasteners used in the installation of StiffWall. Contact The Steel Network for additional design information.

Step 1 - Select StiffWall® Column

This unique column contains an additional return lip to form a double lip, thus creating a stronger, more effective bearing section. The column is the main vertical load-bearing transfer element in StiffWall.

Important Note:

The StiffWall Boot must be used with the StiffWall Column (C/STW). Standard stud (S) sections will not fit inside the StiffWall Boot or

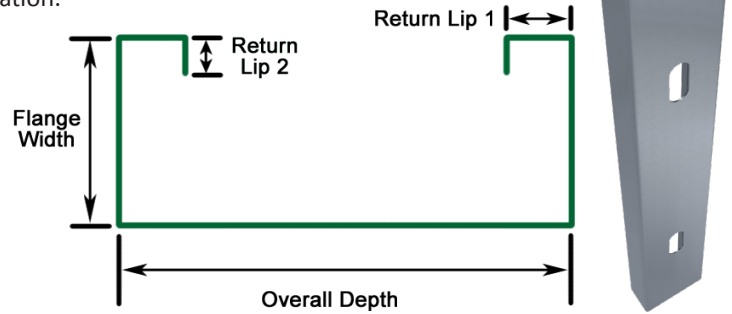

Step 2 - Select StiffWall® Boot

The StiffWall Boot is a critical element enabling StiffWall to simultaneously resist higher loads and provide positive load transfer between elements, something conventional shear wall systems do not provide. Six different StiffWall Boots are available for accommodating changing loading requirements. Refer to the Boot Capacities table data to select the appropriate Boot to fit project conditions.

Step 3 - Determine Column-To-Boot Uplift Fastener Requirement

Attaching to the StiffWall Column with #12 screws or 1/2" A325 bolts, the boot enhances construction efficiency by reducing the number of installed fasteners used in conventional flat strap shear walls. For uplift conditions, calculate the number of screws for the Light and Plus Boots by dividing the total uplift force by the single screw shear. For Small, Medium, Transition, and Large Boots, refer to the chart below for the number of fasteners to the column.

Single Column Allowable Uplift Load (T2) (kips)																	
Column Thickness		Light / Plus Boot (1) # 12 Screw	Small Boot			Medium / Transition Boot						Large Boot					
			350, 362 & 400	550 & 600	800	350, 362 & 400			550 & 600	800	550 & 600	800	550 & 600	800	350, 362 & 400	550 & 600	800
(mils)	(inch)		(2) Bolts	(4) Bolts	(3) Bolts	(4) Bolts	(5) Bolts	(6) Bolts	(8) Bolts	(10) Bolts	(7) Bolts	(14) Bolts					
33	0.0346	0.27	1.71	3.43	3.43	2.57	3.43	4.13	5.14	5.14	6.85	6.85	7.50	8.56	5.27	9.78	11.30
43	0.0451	0.41	2.30	4.59	4.59	3.45	4.59	5.38	6.89	6.89	9.19	9.19	9.77	11.48	6.87	12.74	14.72
54	0.0566	0.57	2.97	5.94	5.94	4.46	5.94	6.75	8.91	8.91	11.88	11.88	12.26	14.75	8.62	15.99	18.48
68	0.0713	0.72	3.88	7.77	7.77	5.83	7.77	8.51	11.65	11.65	15.54	15.54	15.45	18.58	10.86	20.15	23.28
97	0.1017	0.72	5.96	11.92	11.92	8.94	11.92	12.13	17.88	17.88	23.84	23.84	22.04	26.50	15.48	28.73	33.20
118	0.1242	0.72	7.66	14.64	15.32	11.49	15.32	14.82	22.98	22.98	29.36	30.64	26.91	32.36	18.91	35.09	40.55

Back-to-Back and Built-Up Column Allowable Uplift Load (T2) (kips)																	
Column Thickness		Light / Plus Boot (1) # 12 Screw	Small Boot			Medium / Transition Boot						Large Boot					
			350, 362 & 400	550 & 600	800	350, 362 & 400			550 & 600	800	550 & 600	800	550 & 600	800	350, 362 & 400	550 & 600	800
(mils)	(inch)		(2) Bolts	(4) Bolts	(3) Bolts	(4) Bolts	(5) Bolts	(6) Bolts	(8) Bolts	(10) Bolts	(7) Bolts	(14) Bolts					
33	0.0346	N / A	3.43	6.85	6.85	5.14	6.85	8.26	10.28	10.28	13.70	13.70	14.99	17.13	10.54	19.55	22.59
43	0.0451	N / A	4.59	9.19	9.19	6.89	9.19	10.76	13.78	13.78	18.37	18.37	19.54	22.97	13.73	25.49	29.45
54	0.0566	N / A	5.94	11.88	11.88	8.91	11.88	13.51	17.82	17.82	23.77	23.77	24.53	29.50	17.23	31.98	36.96
68	0.0713	N / A	7.77	15.54	15.54	11.65	15.54	17.01	23.31	23.31	31.08	31.08	30.90	37.16	21.71	40.29	46.55
97	0.1017	N / A	10.60	21.21	21.21	15.90	21.21	24.27	31.81	31.81	42.41	42.41	44.07	53.00	30.97	57.47	66.40
118	0.1242	N / A	10.60	21.21	21.21	15.90	21.21	26.51	31.81	31.81	42.41	42.41	53.01	53.01	37.11	70.18	74.22

- Bolts referenced in table are ASTM F3125 Grade A325.
- Refer to the Design Example for uplift requirements.
- Allowable loads for screws are based on AISI S100 Specification, Section J4.
- Maximum allowable load per (1) #12 screw in shear is equal to 0.717 kips, based on commercial screw data.
- Allowable loads for bolts are based on AISI S100, Section J3.
- Maximum allowable shear per (1) 1/2" diameter Grade A325 bolt is equal to 5.30 kips, based on AISI S100, Section J3.4.
- * Compression loads are transferred via full column bearing onto boot.

Shear Wall Systems

StiffWall® SWS Design

Step 4 - Select Stiffwall® Flat Strap

Flat strap is the tension element used to transfer loads between diagonally located strap tracks. Flat strap selection is simplified to 5 strap types (see chart below), with load capacity factored using standard 12ga (97mils) strap track.

Strap Width	Strap Thickness	Yield Strength	Recommended # of screws/ row	Allowable Tension in Single Strap	No. of #12 Screws for Max. Strap Tension
(in)	(mil)	(ksi)	(#)	(kips)	# (kips)
4	54	50	4	5.77	11 (6.26)
6	54		6	8.65	16 (9.10)
8	54		8	11.54	21 (11.95)
8	68		8	14.53	21 (15.06)
10	68		10	18.17	26 (18.65)

- Screw shear values are based on #12 (0.216") screw attached to 97 mil (12 ga) Strap Track.
- Minimum screw spacing = 3d
- Minimum screw edge distance = 1.5d

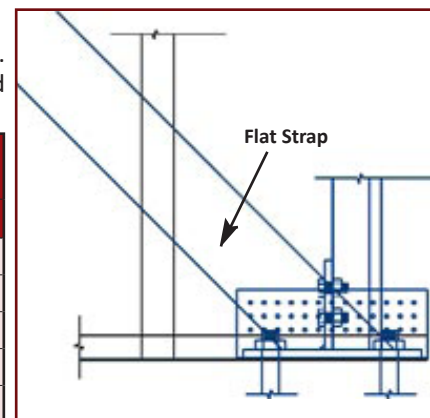

It is recommended to limit the use of 10" flat strap to shear wall panels that have aspect ratio > 0.72:1 (36 degrees)

Step 5 - Condition 1: Anchor Design At Foundation

Refer to Section 3.1.8 in the Hilti North American Product Technical Guide Volume 2, to design anchors at the foundation. For typical details of StiffWall at foundation, see Example Details provided in this catalog. TSN recommends the use of a washer, lock washer, double-nut washer, or tack weld at each end of the bolt.

Allowable Tension and Shear Values of Hilti HIT-RE 500 Adhesive Anchors							
Anchor Diameter	Embedment Depth	Tension			Shear (Non Seismic Design)		
		Based on Bond or Concrete		Based on Steel Strength	Based on Bond or Concrete		Based on Steel Strength
		f'c = 2000 psi	f'c = 4000 psi	ASTM A193 B7	f'c = 2000 psi	f'c = 4000 psi	ASTM A193 B7
(in)	(in)	(lb)	(lb)	(lb)	(lb)	(lb)	(lb)
¾"	4	3,005	5,665	24,805	7,795	11,020	12,780
	7 ⅞	12,495	15,875		17,175	24,290	
	10 ½	14,705	16,185		26,440	37,390	
1 ¼"	5 ⅝	5,760	12,815	50,620	14,760	20,870	26,080
	11 ¼	24,610	31,620		35,050	49,570	

- Bond, concrete, and steel values are referenced from Hilti North American Product Technical Guide Volume 2.
- Apply influence factors for spacing and/or edge distance to concrete/bond values, then compare to the steel strength value. The lesser value is to be used for design.
- Applied tension force shall include tension resulting from prying action produced by deformation of connected parts.
- For design of anchorage under seismic conditions, refer to ACI 318 Appendix D - Anchoring to Concrete provisions.

Step 5 - Condition 2: Through Floor Fastener Connection

Refer to Section J3.4 in the AISI S100-16 Spec to design through floor bolt fasteners. For typical details of StiffWall at foundation, see Example Details provided in this catalog. TSN recommends the use of a washer, lock washer, double-nut washer, or tack weld at each end of the bolt. For typical details of StiffWall at top termination (roof) and through floors, see Example Details provided in this catalog.

Fastening StiffWall® Boot Through Floor		
Allowable Shear and Tension		
Shear Stress (F _v) for A325 Threads (ksi)	Tension Stress (F _t) (ksi)	Combined Shear (F _v) and Tension (F _t)
27.0	45.0	Section J3.4, AISI S100-16 Spec.

- Ensure full bearing between through-floor bolts and the floor slab. Enlarged or notched bolt holes in the slab must be filled with grout.
- Applied tension force shall include tension resulting from prying action produced by deformation of the connected parts.
- The area of a ¾" bolt = 0.60 in² and area of 1 ¼" bolt = 1.23 in².
- Allowable Shear per one ¾" A325 Bolt = 16.2 kips.
- Allowable Shear per one 1 ¼" A325 Bolt = 33.1 kips.
- Allowable Tension per one ¾" A325 Bolt = 27.1 kips.
- Allowable Tension per one 1 ¼" A325 Bolt = 55.2 kips.
- **Boot base plate guide holes for wall widths less than 5½" accommodate ¾" through-rods for Light, Plus, Small, Medium, and Large Boots.**
- **Boot base plate guide holes for wall widths greater than or equal to 5½" accommodate ¾" through-rods for Light, Plus, Small, and Medium Boots. For Large Boots, the base plate guide holes accommodate 1 ¼" through-rods. To transition from a Large Boot with 1 ¼" through rods to any other boot type, a Transition Boot Kit is required, which will accommodate 1 ¼" through-rods on the base of wall, and ¾" through rods at the head of the wall.**

Shear Wall Systems

Pre-Assembled Columns/Boots

Order Information

StiffWalls consist of two Column/Boot Assemblies (at each end post) and Flat Strap (2 sides of X-bracing). The StiffWall fits into or is embedded into the load bearing and non-load bearing walls. Do your stud take off as normal and order the Column/Boot Assembly and the Flat Strap as separate items. When ordering columns, determine the height of the bearing wall. TSN will size the StiffWall Column/Boot Assembly factoring in the dimensions of the boots at top and bottom. Each column is shipped with the boots pre-attached at the top and bottom as shown in the image to the right.

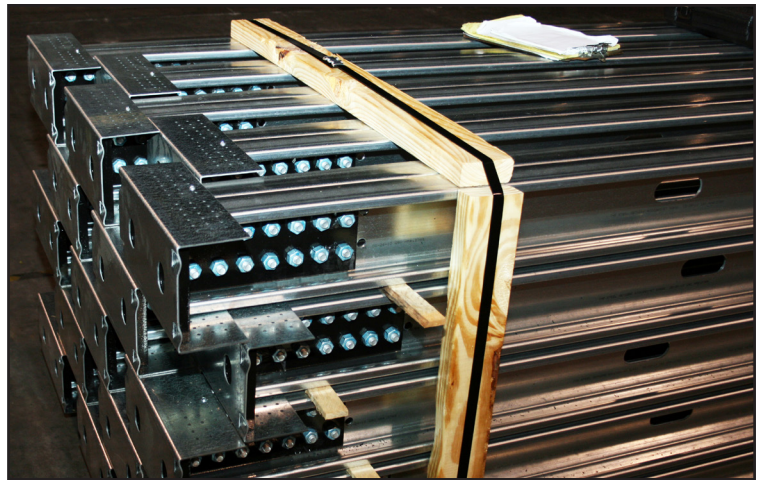

The added value of the pre-installed boots minimizes tolerance issues during erection. Simply specify the clear span of the bearing wall system and TSN will ship the Column/Boot assembly to meet the given wall height at a tolerance of $+0/-1/8$ ".

Nomenclature

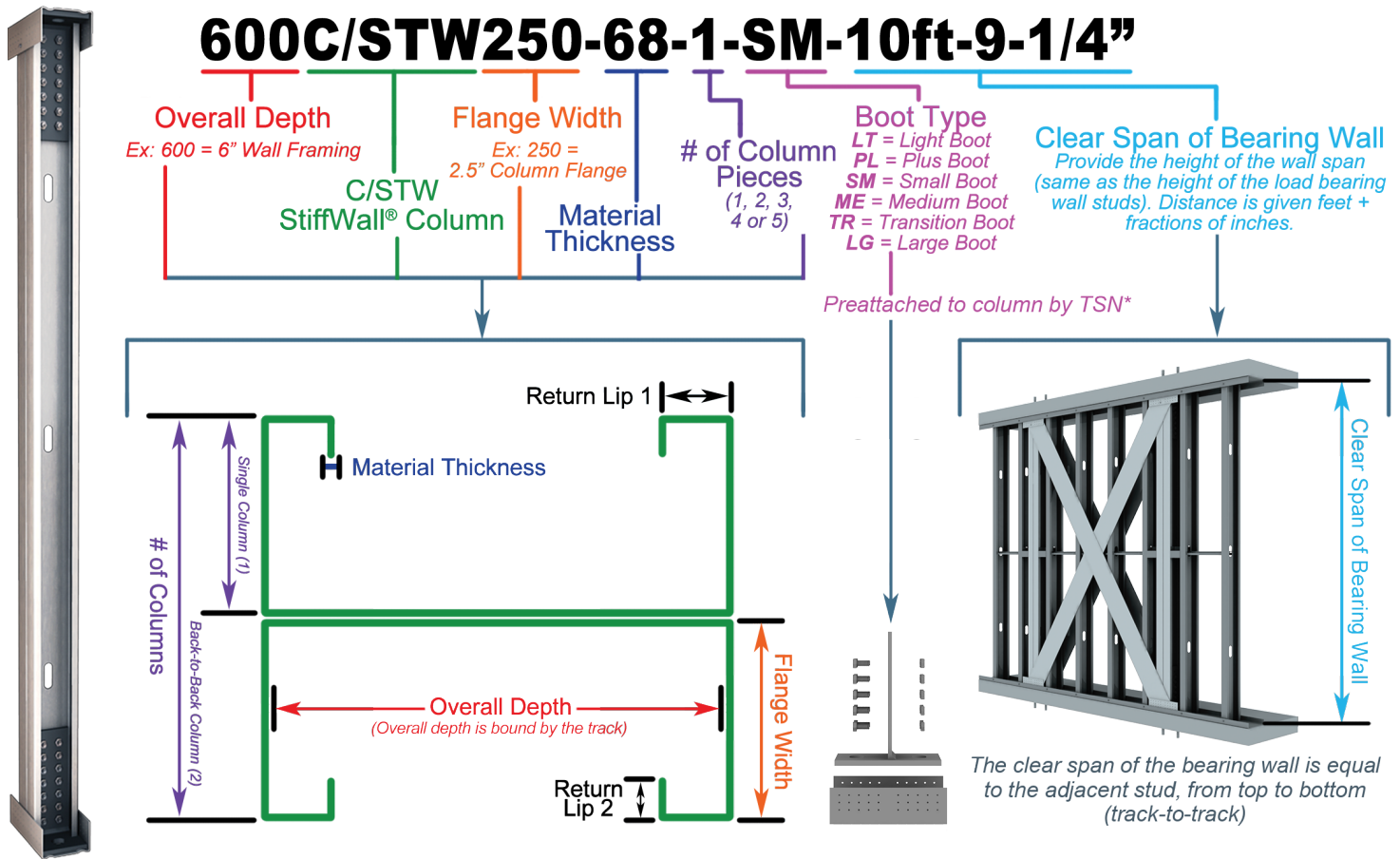

Shear Wall Systems Single & Back-to-Back StiffWall® Column Product Profile

600C/STW250-68

Overall Depth

C/STW
StiffWall® Column

Flange Width

Material Thickness

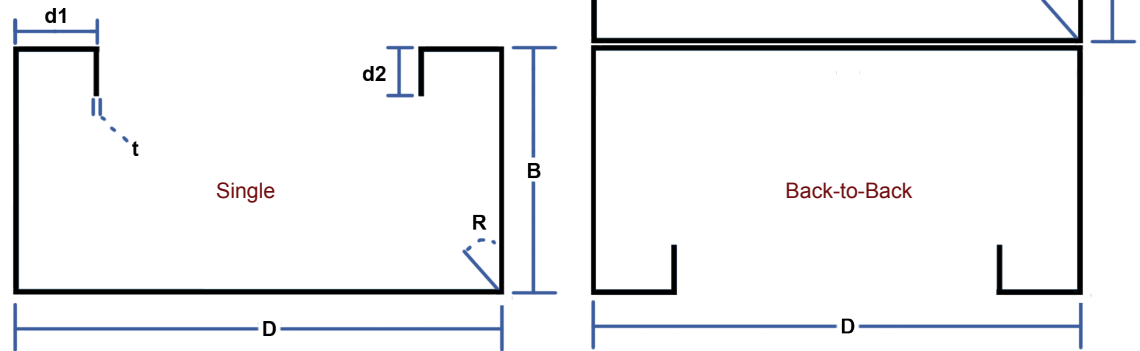

Material Properties

ASTM A1003/A1003M
Structural Grade 50 (340)
Type H, ST50H (ST340H):
50ksi (340MPa) minimum
yield strength, 65ksi
(450MPa) minimum tensile
strength with ASTM A653/
A653M G60 (Z180) hot
dipped galvanized coating.

Single & Back-to-Back StiffWall® Column Product Profile							
Section (All 50 ksi)	Overall Depth	Flange Width	Return Lip 1	Return Lip 2	Inside Bend Radius	Design Thickness	Unit Weight
	D	B	d1	d2	R	t	(lbs/ft)
	(in)	(in)	(in)	(in)	(in)	(in)	
350C/STW200-33	3.139	2.000	0.5892	0.5	0.105	0.0346	1.035
350C/STW200-43	3.139	2.000	0.6102	0.5	0.105	0.0451	1.344
350C/STW200-54	3.139	2.000	0.6332	0.5	0.105	0.0566	1.680
350C/STW200-68	3.139	2.000	0.6626	0.5	0.105	0.0713	2.104
350C/STW200-97	3.139	2.000	0.7234	0.5	0.105	0.1017	2.967
350C/STW200-118	3.139	2.000	0.7684	0.5	0.105	0.1242	3.587
362C/STW200-33	3.264	2.000	0.5892	0.5	0.105	0.0346	1.050
362C/STW200-43	3.264	2.000	0.6102	0.5	0.105	0.0451	1.364
362C/STW200-54	3.264	2.000	0.6332	0.5	0.105	0.0566	1.704
362C/STW200-68	3.264	2.000	0.6626	0.5	0.105	0.0713	2.135
362C/STW200-97	3.264	2.000	0.7234	0.5	0.105	0.1017	3.010
362C/STW200-118	3.264	2.000	0.7684	0.5	0.105	0.1242	3.639
400C/STW200-33	3.639	2.000	0.5892	0.5	0.105	0.0346	1.094
400C/STW200-43	3.639	2.000	0.6102	0.5	0.105	0.0451	1.421
400C/STW200-54	3.639	2.000	0.6332	0.5	0.105	0.0566	1.776
400C/STW200-68	3.639	2.000	0.6626	0.5	0.105	0.0713	2.226
400C/STW200-97	3.639	2.000	0.7234	0.5	0.105	0.1017	3.140
400C/STW200-118	3.639	2.000	0.7684	0.5	0.105	0.1242	3.798
550C/STW250-43	5.139	2.500	0.6102	0.5	0.105	0.0451	1.805
550C/STW250-54	5.139	2.500	0.6332	0.5	0.105	0.0566	2.258
550C/STW250-68	5.139	2.500	0.6626	0.5	0.105	0.0713	2.832
550C/STW250-97	5.139	2.500	0.7234	0.5	0.105	0.1017	4.005
550C/STW250-118	5.139	2.500	0.7684	0.5	0.105	0.1242	4.853
600C/STW250-43	5.639	2.500	0.6102	0.5	0.105	0.0451	1.882
600C/STW250-54	5.639	2.500	0.6332	0.5	0.105	0.0566	2.354
600C/STW250-68	5.639	2.500	0.6626	0.5	0.105	0.0713	2.954
600C/STW250-97	5.639	2.500	0.7234	0.5	0.105	0.1017	4.178
600C/STW250-118	5.639	2.500	0.7684	0.5	0.105	0.1242	5.064
800C/STW250-43	7.639	2.500	0.6102	0.5	0.105	0.0451	2.189
800C/STW250-54	7.639	2.500	0.6332	0.5	0.105	0.0566	2.739
800C/STW250-68	7.639	2.500	0.6626	0.5	0.105	0.0713	3.439
800C/STW250-97	7.639	2.500	0.7234	0.5	0.105	0.1017	4.871
800C/STW250-118	7.639	2.500	0.7684	0.5	0.105	0.1242	5.908

Standard (S) section studs will not fit in the StiffWall® Boot and should not be considered as a substitute for the StiffWall Column.

Material Properties

ASTM A1003/A1003M Structural Grade 50 (340) Type H, ST50H (ST340H): 50ksi (340MPa) minimum yield strength, 65ksi (450MPa) minimum tensile strength with ASTM A653/A653M G60 (Z180) hot dipped galvanized coating.

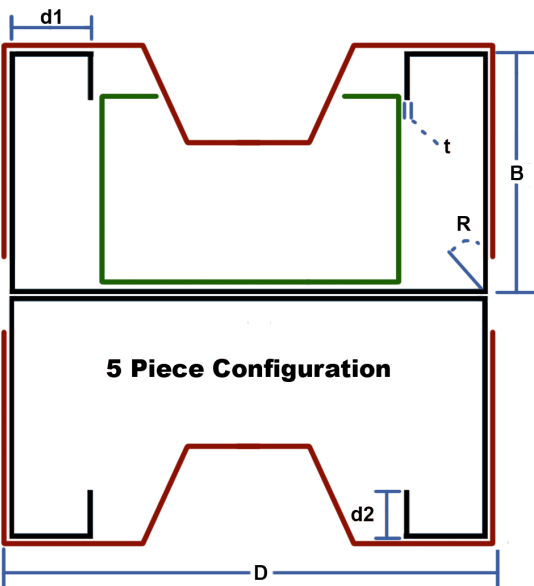
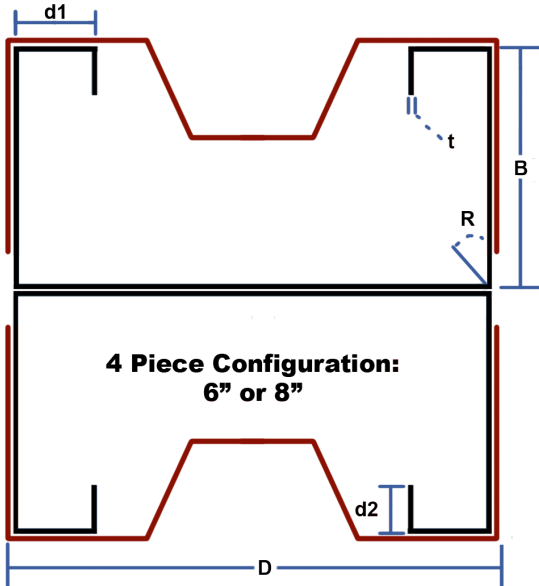
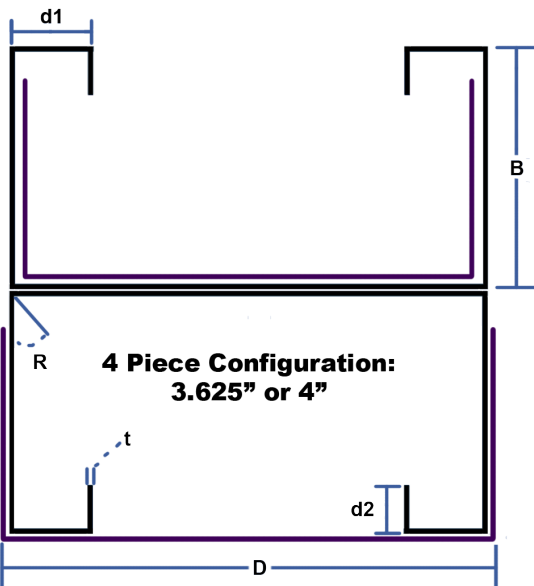
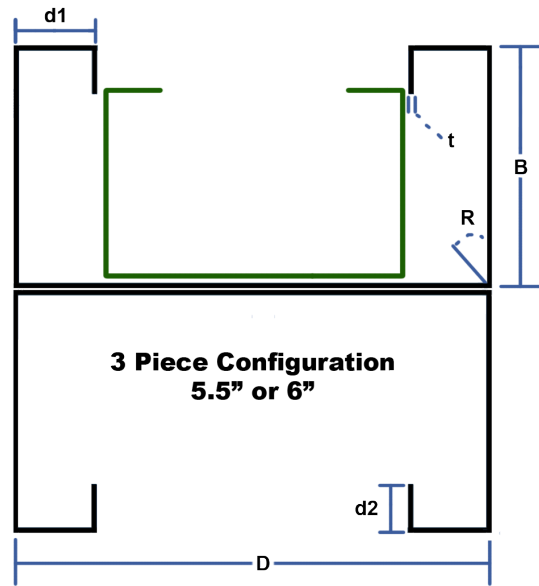
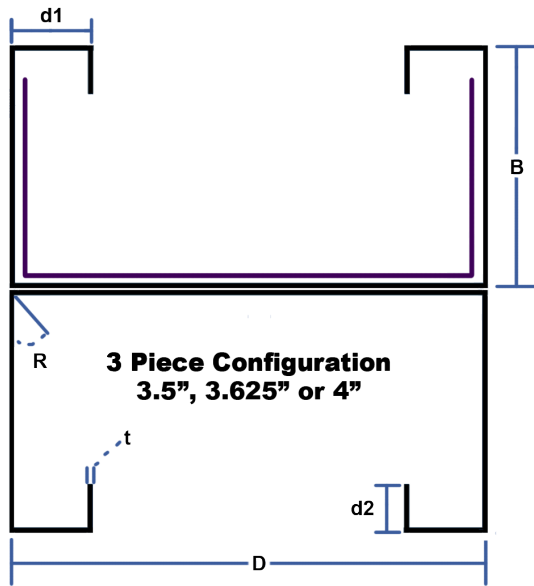

StiffWall® Column (C/STW)

- Back-to-Back (C/STW)**
- Standard Stud (S)**
- SigmaPan (SGP)**
- Track (T)**

Built-Up StiffWall® Column Product Profile							
Depth (in)	Section (All 50 ksi)	Components	Overall Depth	Flange Width	Return Lip 1	Design Thickness	Unit Weight
			D	B	d1	t	(lbs/ft)
			(in)	(in)	(in)	(in)	
350	(3P) 350C/STW200-97	(2) 350C/STW200-97	3.139	2.000	0.7234	0.1017	7.793
		275T150-97	2.750	1.500	N/A	0.1017	
	(3P) 350C/STW200-118	(2) 350C/STW200-118	3.139	2.000	0.7684	0.1242	9.043
		275T150-97	2.750	1.500	N/A	0.1017	
362	(3P) 362C/STW200-97	(2) 362C/STW200-97	3.264	2.000	0.7234	0.1017	7.879
		275T150-97	2.750	1.500	N/A	0.1017	
	(3P) 362C/STW200-118	(2) 362C/STW200-118	3.264	2.000	0.7684	0.1242	9.149
		275T150-97	2.750	1.500	N/A	0.1017	
	(4P) 362C/STW200-97	(2) 362*C/STW200-97	3.029	2.000	0.7234	0.1017	9.840
		275T150-97	2.750	1.500	N/A	0.1017	
		326T162-97	3.264	1.625	N/A	0.1017	
	(4P) 362C/STW200-118	(2) 362*C/STW200-118	3.029	2.000	0.7684	0.1242	11.073
		275T150-97	2.750	1.500	N/A	0.1017	
		326T162-97	3.264	1.625	N/A	0.1017	
400	(3P) 400C/STW200-97	(2) 400C/STW200-97	3.639	2.000	0.7234	0.1017	8.139
		275T150-97	2.750	1.500	N/A	0.1017	
	(3P) 400C/STW200-118	(2) 400C/STW200-118	3.639	2.000	0.7684	0.1242	9.466
		275T150-97	2.750	1.500	N/A	0.1017	
	(4P) 400C/STW200-97	(2) 400*C/STW200-97	3.404	2.000	0.7234	0.1017	10.229
		275T150-97	2.750	1.500	N/A	0.1017	
		364T162-97	3.639	1.625	N/A	0.1017	
	(4P) 400C/STW200-118	(2) 400*C/STW200-118	3.404	2.000	0.7684	0.1242	11.520
275T150-97		2.750	1.500	N/A	0.1017		
364T162-97		3.639	1.625	N/A	0.1017		
550	(3P) 550C/STW250-97	(2) 550C/STW250-97	5.139	2.500	0.7234	0.1017	10.604
		400S162-97	4.000	1.625	0.5000	0.1017	
	(3P) 550C/STW250-118	(2) 550C/STW250-118	5.139	2.500	0.7684	0.1242	12.313
		400S162-97	4.000	1.625	0.5000	0.1017	

* Overall Depth (D) varies from Single and Back-to-Back sections

Built-Up StiffWall® Column Product Profile

Built-Up StiffWall® Column Product Profile							
Depth (in)	Section (All 50 ksi)	Components	Overall Depth	Flange Width	Return Lip 1	Design Thickness	Unit Weight (lbs/ft)
			D	B	d1	t	
			(in)	(in)	(in)	(in)	
600	(3P) 600C/STW250-97	(2) 600C/STW250-97	5.639	2.500	0.7234	0.1017	10.950
		400S162-97	4.000	1.625	0.5000	0.1017	
	(3P) 600C/STW250-118	(2) 600C/STW250-118	5.639	2.500	0.7684	0.1242	12.736
		400S162-97	4.000	1.625	0.5000	0.1017	
	(4P) 600C/STW250-97	(2) 600*C/STW250-97	5.404	2.500	0.7234	0.1017	15.703
		(2) 564SGP225-97	5.639	2.250	N/A	0.1017	
	(4P) 600C/STW250-118	(2) 600*C/STW250-118	5.404	2.500	0.7684	0.1242	17.454
		(2) 564SGP225-97	5.639	2.250	N/A	0.1017	
	(5P) 600C/STW250-97	(2) 600*C/STW250-97	5.404	2.500	0.7234	0.1017	18.297
		(2) 564SGP225-97	5.639	2.250	N/A	0.1017	
		400S162-97	4.000	1.625	0.5000	0.1017	
	(5P) 600C/STW250-118	(2) 600*C/STW250-118	5.404	2.500	0.7684	0.1242	20.047
		(2) 564SGP225-97	5.639	2.250	N/A	0.1017	
		400S162-97	4.000	1.625	0.5000	0.1017	
	800	(3P) 800C/STW250-97	(2) 800C/STW250-97	7.639	2.500	0.7234	0.1017
600S200-97			6.000	2.000	0.6250	0.1017	
(3P) 800C/STW250-118		(2) 800C/STW250-118	7.639	2.500	0.7684	0.1242	15.119
		600S200-97	6.000	2.000	0.6250	0.1017	
(4P) 800C/STW250-97		(2) 800*C/STW250-97	7.404	2.500	0.7234	0.1017	18.472
		(2) 764SGP225-97	7.639	2.250	N/A	0.1017	
(4P) 800C/STW250-118		(2) 800*C/STW250-118	7.404	2.500	0.7684	0.1242	20.529
		(2) 764SGP225-97	7.639	2.250	N/A	0.1017	
(5P) 800C/STW250-97		(2) 800*C/STW250-97	7.404	2.500	0.7234	0.1017	21.758
		(2) 764SGP225-97	7.639	2.250	N/A	0.1017	
		600S162-97	6.000	1.625	0.5000	0.1017	
(5P) 800C/STW250-118		(2) 800*C/STW250-118	7.404	2.500	0.7684	0.1242	23.814
		(2) 764SGP225-97	7.639	2.250	N/A	0.1017	
		600S162-97	6.000	1.625	0.5000	0.1017	

* Overall Depth (D) varies from Single and Back-to-Back sections

Important Notes

1. Calculated properties are based on AISI S100-16 Spec, "North American Specification for the Design of Cold-Formed Steel Structural Members".
2. Effective properties incorporate the strength increase from the cold-work of forming as applicable per AISI S100-16 Spec, Sec. A3.3.2 (3).
3. Tabulated gross properties are based on the full-unreduced cross section of the studs, away from punchouts.
4. Net effective section properties are calculated at a cross section through the punchout.
5. Allowable moment is the lesser of M_{al} and M_{ad} . Stud distortional buckling is based on an assumed $k_{\phi} = 0$.
6. For deflection calculations, use the effective moment of inertia.
7. The effective moment of inertia for deflection is calculated at a stress which results in a section modulus such that the stress times the section modulus at that stress is equal to the allowable moment. AISI S100-16 Procedure I for Serviceability Determination has been used. Increases in the effective moment of inertia (I_{xe}) may be possible at lower stress levels. Any modified values would be required to be calculated by a qualified engineer.
8. The StiffWall Column must be used with the StiffWall Boot. Standard (S) sections will not fit inside the StiffWall Boot or Strap Track.



Single StiffWall® Column Section Properties																
Section (All 50 ksi)	Gross Properties						Effective Properties 50 ksi									
	Area	I_x	S_x	R_x	I_y	R_y	$A_{e(net)}$	I_{xe}	S_{xe}	M_{al}	$S_{xe(net)}$	$M_{al(net)}$	M_{ad}	$M_{ad(net)}$	V_{ag}	V_{anet}
	(in ²)	(in ⁴)	(in ³)	(in)	(in ⁴)	(in)	(in ²)	(in ⁴)	(in ³)	(in-k)	(in ³)	(in-k)	(in-k)	(in-k)	(lb)	(lb)
350C/STW200-33	0.304	0.489	0.312	1.268	0.185	0.781	0.200	0.477	0.267	8.005	0.248	7.431	7.569	7.355	1,260	459
350C/STW200-43	0.395	0.629	0.401	1.262	0.239	0.777	0.290	0.629	0.371	11.115	0.355	10.630	10.720	10.407	2,141	589
350C/STW200-54	0.494	0.777	0.495	1.255	0.295	0.774	0.378	0.777	0.476	14.240	0.462	13.843	14.297	13.882	2,988	643
350C/STW200-68	0.618	0.960	0.612	1.246	0.366	0.769	0.511	0.960	0.612	20.298	0.599	19.876	20.298	19.479	3,725	622
350C/STW200-97	0.872	1.315	0.838	1.228	0.502	0.759	0.719	1.315	0.838	28.703	0.819	28.083	28.703	28.079	5,197	580
350C/STW200-118	1.056	1.557	0.992	1.215	0.596	0.752	0.869	1.557	0.992	34.781	0.970	34.006	34.781	34.000	6,242	578
362C/STW200-33	0.309	0.535	0.328	1.317	0.188	0.781	0.201	0.523	0.282	8.446	0.260	7.794	7.915	7.692	1,235	491
362C/STW200-43	0.401	0.689	0.422	1.311	0.242	0.778	0.291	0.689	0.391	11.717	0.373	11.161	11.222	10.896	2,141	644
362C/STW200-54	0.501	0.852	0.522	1.304	0.300	0.774	0.380	0.852	0.501	15.003	0.486	14.546	14.986	14.551	3,121	736
362C/STW200-68	0.627	1.053	0.645	1.295	0.371	0.769	0.520	1.053	0.645	21.404	0.633	20.999	21.404	20.565	3,892	713
362C/STW200-97	0.885	1.443	0.884	1.277	0.510	0.760	0.732	1.443	0.884	30.305	0.867	29.708	30.305	29.704	5,436	668
362C/STW200-118	1.071	1.711	1.048	1.264	0.606	0.752	0.885	1.711	1.048	36.756	1.027	36.011	36.756	36.005	6,534	636
400C/STW200-33	0.322	0.689	0.379	1.464	0.197	0.782	0.202	0.674	0.328	9.806	0.297	8.882	8.958	8.711	1,097	546
400C/STW200-43	0.418	0.887	0.488	1.458	0.253	0.779	0.293	0.887	0.453	13.574	0.426	12.750	12.742	12.376	2,141	808
400C/STW200-54	0.522	1.099	0.604	1.451	0.314	0.775	0.385	1.099	0.579	17.350	0.556	16.650	17.072	16.581	3,372	1,002
400C/STW200-68	0.654	1.360	0.748	1.442	0.388	0.770	0.533	1.360	0.748	24.808	0.732	21.907	24.516	21.768	4,394	1,019
400C/STW200-97	0.923	1.871	1.028	1.424	0.534	0.761	0.770	1.871	1.028	35.237	1.013	34.703	35.237	34.699	6,151	966
400C/STW200-118	1.118	2.224	1.222	1.410	0.634	0.753	0.931	2.224	1.222	42.842	1.203	42.175	42.842	42.169	7,407	928
550C/STW250-43	0.530	2.281	0.888	2.074	0.491	0.962	0.297	2.263	0.748	22.395	0.748	22.395	19.964	19.452	1,687	1,156
550C/STW250-54	0.663	2.835	1.103	2.067	0.609	0.958	0.394	2.835	0.952	28.495	0.952	28.495	27.219	26.494	3,350	1,817
550C/STW250-68	0.832	3.527	1.373	2.059	0.757	0.954	0.541	3.527	1.240	37.123	1.240	37.123	37.025	36.026	5,352	2,284
550C/STW250-97	1.177	4.902	1.908	2.041	1.050	0.944	0.944	4.902	1.873	62.630	1.873	62.630	63.109	61.411	9,011	2,646
550C/STW250-118	1.428	5.873	2.286	2.028	1.255	0.937	1.192	5.873	2.286	77.850	2.286	77.850	77.850	77.387	10,900	2,585
600C/STW250-43	0.553	2.825	1.002	2.261	0.508	0.958	0.298	2.808	0.849	25.412	0.849	25.412	22.108	21.553	1,529	1,205
600C/STW250-54	0.692	3.514	1.246	2.254	0.630	0.955	0.395	3.514	1.079	32.300	1.079	32.300	30.211	29.419	3,035	1,895
600C/STW250-68	0.868	4.376	1.552	2.245	0.783	0.950	0.544	4.376	1.404	42.024	1.404	42.024	41.209	40.111	5,352	2,632
600C/STW250-97	1.228	6.093	2.161	2.228	1.086	0.941	0.953	6.093	2.121	70.909	2.121	70.909	70.573	68.682	9,965	3,380
600C/STW250-118	1.490	7.308	2.592	2.215	1.299	0.934	1.209	7.308	2.592	88.286	2.592	88.286	88.286	87.864	12,064	3,310
800C/STW250-43	0.643	5.723	1.498	2.983	0.563	0.936	0.300	5.718	1.169	35.009	1.169	35.009	30.715	30.002	1,112	1,112
800C/STW250-54	0.805	7.131	1.867	2.976	0.700	0.932	0.399	7.131	1.627	48.704	1.627	48.704	42.289	41.256	2,206	2,098
800C/STW250-68	1.011	8.900	2.330	2.968	0.870	0.928	0.551	8.900	2.121	63.488	2.121	63.488	58.224	56.756	4,427	3,326
800C/STW250-97	1.431	12.452	3.260	2.950	1.207	0.918	0.973	12.452	3.199	106.947	3.199	106.947	101.278	98.639	10,888	5,676
800C/STW250-118	1.739	14.990	3.925	2.936	1.444	0.911	1.246	14.990	3.925	133.672	3.925	133.672	132.999	129.679	16,239	6,877

Single StiffWall® Column Section Properties (continued)							
Section (All 50 ksi)	Torsional Properties						L _u (in)
	Jx10 ³ (in ⁴)	C _w (in ⁶)	X _o (in)	m (in)	R _o (in)	β	
	350C/STW200-33	0.121	0.607	-2.038	1.209	2.524	0.348
350C/STW200-43	0.268	0.787	-2.032	1.206	2.515	0.347	47.98
350C/STW200-54	0.527	0.982	-2.026	1.203	2.506	0.346	48.31
350C/STW200-68	1.048	1.226	-2.018	1.199	2.493	0.345	48.82
350C/STW200-97	3.006	1.718	-2.001	1.190	2.467	0.342	50.15
350C/STW200-118	5.427	2.068	-1.988	1.183	2.448	0.341	51.40
362C/STW200-33	0.123	0.644	-2.016	1.198	2.531	0.366	47.36
362C/STW200-43	0.272	0.834	-2.010	1.195	2.523	0.365	47.60
362C/STW200-54	0.535	1.040	-2.004	1.192	2.513	0.364	47.90
362C/STW200-68	1.063	1.299	-1.996	1.188	2.501	0.363	48.36
362C/STW200-97	3.050	1.817	-1.979	1.179	2.475	0.361	49.58
362C/STW200-118	5.507	2.186	-1.966	1.172	2.455	0.359	50.73
400C/STW200-33	0.128	0.764	-1.952	1.167	2.562	0.420	46.47
400C/STW200-43	0.283	0.989	-1.946	1.164	2.553	0.419	46.65
400C/STW200-54	0.557	1.232	-1.940	1.161	2.544	0.418	46.88
400C/STW200-68	1.108	1.536	-1.932	1.157	2.531	0.417	47.23
400C/STW200-97	3.181	2.143	-1.915	1.149	2.505	0.415	48.18
400C/STW200-118	5.747	2.573	-1.903	1.142	2.485	0.414	49.07
550C/STW250-43	0.360	3.069	-2.203	1.321	3.175	0.518	54.01
550C/STW250-54	0.708	3.821	-2.197	1.318	3.165	0.518	51.12
550C/STW250-68	1.410	4.763	-2.189	1.314	3.153	0.518	54.30
550C/STW250-97	4.058	6.644	-2.173	1.306	3.127	0.517	54.79
550C/STW250-118	7.343	7.978	-2.161	1.299	3.108	0.517	55.27
600C/STW250-43	0.375	3.671	-2.134	1.288	3.253	0.570	53.58
600C/STW250-54	0.739	4.568	-2.128	1.285	3.244	0.569	53.66
600C/STW250-68	1.471	5.692	-2.121	1.281	3.231	0.569	53.78
600C/STW250-97	4.233	7.932	-2.104	1.273	3.205	0.569	54.15
600C/STW250-118	7.663	9.517	-2.092	1.266	3.186	0.569	54.51
800C/STW250-43	0.436	6.814	-1.904	1.176	3.661	0.729	52.43
800C/STW250-54	0.860	8.472	-1.898	1.173	3.651	0.730	52.42
800C/STW250-68	1.712	10.544	-1.890	1.169	3.639	0.730	52.41
800C/STW250-97	4.934	14.662	-1.873	1.160	3.613	0.731	52.47
800C/STW250-118	8.940	17.565	-1.861	1.153	3.594	0.732	52.55

* Overall Depth (D) varies from Single and Back-to-Back sections

Important Notes

1. Allowable loads are based on specified weak axis and torsional bracing for axial load calculation.
2. Sections are punched with a standard punch-out 1.5" wide located along the centerline of the web 24" o.c.
3. Allowable loads are based on a punched section for axial load calculation.
4. The allowable axial strength for distortional buckling is based on an assumed $k_y = 0$.
5. Weak axis and torsional bracing should have sufficient stiffness and strength to resist the axial load.
6. Strength increase due to cold work of forming is incorporated in calculating allowable loads as per AISI S100-16 Spec, Sec. A3.3.2 (3).
7. The StiffWall Column must be used with the StiffWall Boot. Standard (S) sections will not fit inside the StiffWall Boot or Strap Track.
8. StiffWall Columns are delivered to the job site with Boots pre-attached at the top and bottom for fast installation.

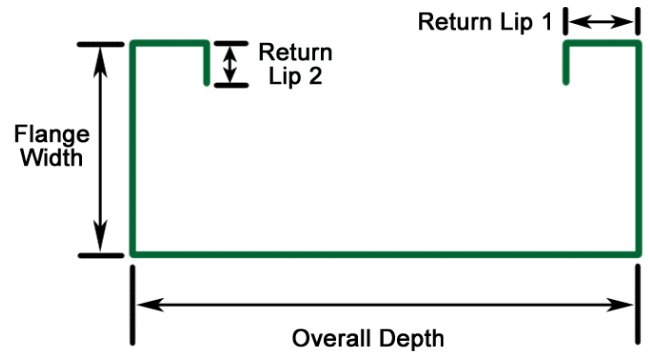

Single Section: Axial Compression Load (kips)												
Single Section (All 50 ksi)	Maximum Unbraced Length = 48"				Maximum Unbraced Length = 60"				Max Unbraced Length = Full Height			
	SW Column Height (ft)				SW Column Height (ft)				SW Column Height (ft)			
	9	10	12	14	9	10	12	14	9	10	12	14
350C/STW200-33	2.64	2.41	1.95	1.57	2.12	1.96	1.64	1.37	0.91	0.75	0.54	0.42
350C/STW200-43	3.56	3.18	2.53	2.03	2.80	2.57	2.14	1.78	1.25	1.04	0.76	0.60
350C/STW200-54	4.47	3.98	3.15	2.52	3.55	3.25	2.70	2.23	1.66	1.40	1.05	0.84
350C/STW200-68	5.64	5.00	3.95	3.15	4.55	4.14	3.41	2.81	2.29	1.95	1.51	1.23
350C/STW200-97	8.10	7.14	5.57	4.40	6.75	6.09	4.94	4.02	3.96	3.45	2.76	2.08
350C/STW200-118	9.97	8.73	6.75	5.31	8.53	7.63	6.10	4.91	5.55	4.84	3.36	2.47
362C/STW200-33	2.78	2.56	2.09	1.71	2.26	2.09	1.77	1.49	0.97	0.80	0.57	0.44
362C/STW200-43	3.83	3.45	2.75	2.21	3.02	2.78	2.33	1.94	1.32	1.10	0.81	0.63
362C/STW200-54	4.81	4.32	3.44	2.76	3.83	3.51	2.93	2.43	1.76	1.48	1.11	0.89
362C/STW200-68	6.06	5.44	4.30	3.44	4.90	4.47	3.71	3.06	2.42	2.06	1.59	1.30
362C/STW200-97	8.79	7.76	6.08	4.82	7.28	6.59	5.37	4.38	4.18	3.64	2.89	2.12
362C/STW200-118	10.82	9.50	7.38	5.81	9.19	8.25	6.64	5.36	5.86	4.93	3.43	2.52
400C/STW200-33	3.15	2.95	2.53	2.09	2.62	2.47	2.13	1.82	1.14	0.94	0.68	0.52
400C/STW200-43	4.44	4.12	3.42	2.81	3.61	3.36	2.89	2.46	1.56	1.29	0.94	0.73
400C/STW200-54	5.75	5.33	4.38	3.53	4.70	4.35	3.68	3.08	2.06	1.73	1.29	1.03
400C/STW200-68	7.33	6.73	5.49	4.42	6.01	5.54	4.66	3.89	2.82	2.39	1.84	1.50
400C/STW200-97	10.73	9.75	7.77	6.20	8.93	8.16	6.76	5.57	4.83	4.21	3.05	2.24
400C/STW200-118	13.23	11.96	9.45	7.50	11.30	10.25	8.38	6.84	6.43	5.21	3.62	2.66
550C/STW250-43	6.34	6.20	5.84	5.39	5.76	5.64	5.30	4.89	2.84	2.37	1.74	1.35
550C/STW250-54	8.32	8.14	7.83	7.30	7.76	7.61	7.18	6.53	3.80	3.19	2.37	1.85
550C/STW250-68	11.94	11.55	10.62	9.57	10.51	10.20	9.46	8.59	5.19	4.38	3.25	2.54
550C/STW250-97	18.21	17.59	16.15	14.50	16.18	15.68	14.50	13.12	8.40	7.11	5.43	4.41
550C/STW250-118	23.05	22.23	20.22	17.92	20.51	19.80	18.12	16.19	11.19	9.62	7.46	5.48
600C/STW250-43	6.59	6.46	6.17	5.80	6.03	5.93	5.69	5.34	3.11	2.60	1.91	1.48
600C/STW250-54	8.66	8.49	8.14	7.81	8.02	7.94	7.68	7.25	4.17	3.50	2.61	2.05
600C/STW250-68	12.38	12.18	11.48	10.55	11.20	10.95	10.32	9.57	5.70	4.81	3.63	2.87
600C/STW250-97	19.32	18.81	17.57	16.12	17.32	16.91	15.93	14.72	9.48	8.02	6.09	4.78
600C/STW250-118	24.60	23.93	22.31	20.42	22.18	21.64	20.34	18.75	12.57	10.76	7.78	5.71
800C/STW250-43	7.13	7.08	6.94	6.74	6.64	6.60	6.49	6.35	3.93	3.27	2.40	1.86
800C/STW250-54	9.44	9.37	9.17	8.90	8.76	8.71	8.56	8.36	5.25	4.40	3.27	2.56
800C/STW250-68	13.47	13.37	13.10	12.74	12.59	12.52	12.34	12.03	7.13	6.02	4.51	3.46
800C/STW250-97	21.88	21.65	21.03	20.20	19.95	19.78	19.34	18.73	11.40	9.51	6.95	5.32
800C/STW250-118	28.13	27.83	27.04	25.95	25.76	25.54	24.96	24.16	14.49	12.08	8.79	6.48

Shear Wall Systems

Back-to-Back Axial Load Tables

Important Notes

1. Allowable loads are based on specified weak axis and torsional bracing for axial load calculation.
2. Sections are punched with a standard punch-out 1.5" wide located along the centerline of the web 24" o.c.
3. Allowable loads are based on a punched section for axial load calculation.
4. The allowable axial strength for distortional buckling is based on an assumed $k_{\phi} = 0$.
5. Weak axis and torsional bracing should have sufficient stiffness and strength to resist the axial load.
6. Strength increase due to cold work of forming is incorporated in calculating allowable loads as per AISI S100-16 Spec, Sec. A3.3.2 (3).
7. Allowable loads for Back-to-Back sections are based on maximum attachment interval of 24" o.c. via weld, bolts, or screws.
8. The StiffWall Column must be used with the StiffWall Boot. Standard (S) sections will not fit inside the StiffWall Boot or Strap Track.
9. StiffWall Columns are delivered to the job site with Boots pre-attached at the top and bottom for fast installation.

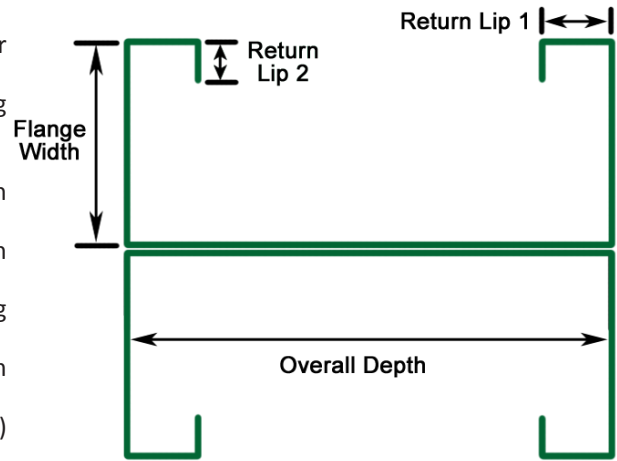

Back-to-Back (Fastener Spacing = 24 in): Axial Compression Load (kips)

Back-to-Back Section (All 50 ksi)	Maximum Unbraced Length = 48"				Maximum Unbraced Length = 60"				Max Unbraced Length = Full Height			
	SW Column Height (ft)				SW Column Height (ft)				SW Column Height (ft)			
	9	10	12	14	9	10	12	14	9	10	12	14
350C/STW200-33-2	7.40	6.71	5.34	4.06	7.40	6.71	5.34	4.06	4.51	3.76	2.73	2.10
350C/STW200-43-2	10.62	9.45	7.13	5.24	10.62	9.45	7.13	5.24	6.28	5.25	3.90	3.09
350C/STW200-54-2	13.33	11.77	8.80	6.47	13.33	11.77	8.80	6.47	8.48	7.18	5.50	4.48
350C/STW200-68-2	17.11	14.93	10.86	7.98	17.11	14.93	10.86	7.98	11.90	10.27	8.15	6.50
350C/STW200-97-2	23.89	20.68	14.84	10.90	23.89	20.68	14.84	10.90	20.21	17.12	12.21	9.11
350C/STW200-118-2	28.66	24.67	17.54	12.89	28.66	24.67	17.54	12.89	24.44	20.63	14.71	10.98
362C/STW200-33-2	7.65	7.00	5.68	4.40	7.65	7.00	5.68	4.40	4.56	3.80	2.78	2.14
362C/STW200-43-2	11.03	9.95	7.75	5.75	11.03	9.95	7.75	5.75	6.40	5.34	3.96	3.13
362C/STW200-54-2	14.11	12.57	9.62	7.11	14.11	12.57	9.62	7.11	8.62	7.29	5.56	4.52
362C/STW200-68-2	17.54	15.60	11.89	8.78	17.54	15.60	11.89	8.78	11.98	10.38	8.20	6.52
362C/STW200-97-2	25.45	22.28	16.34	12.01	25.45	22.28	16.34	12.01	20.35	17.20	12.25	9.15
362C/STW200-118-2	30.62	26.66	19.34	14.21	30.62	26.66	19.34	14.21	24.61	20.72	14.77	11.03
400C/STW200-33-2	8.29	7.72	6.53	5.35	8.29	7.72	6.53	5.35	4.66	3.89	2.87	2.24
400C/STW200-43-2	12.04	11.18	9.21	7.27	12.04	11.18	9.21	7.27	6.60	5.56	4.13	3.24
400C/STW200-54-2	15.77	14.45	11.81	9.25	15.77	14.45	11.81	9.25	9.00	7.58	5.73	4.62
400C/STW200-68-2	20.30	18.48	14.84	11.44	20.30	18.48	14.84	11.44	12.40	10.67	8.34	6.59
400C/STW200-97-2	29.85	26.83	20.96	15.70	29.85	26.83	20.96	15.70	20.76	17.41	12.39	9.24
400C/STW200-118-2	36.11	32.33	25.03	18.63	36.11	32.33	25.03	18.63	25.09	20.98	14.94	11.15
550C/STW250-43-2	14.58	14.16	13.22	12.19	13.93	13.93	13.22	12.19	9.37	8.02	5.90	4.59
550C/STW250-54-2	19.21	18.63	17.33	16.08	18.37	18.37	17.33	16.08	12.67	10.82	8.08	6.37
550C/STW250-68-2	27.22	26.38	24.66	22.40	26.12	26.12	24.66	22.40	17.18	14.93	11.35	9.12
550C/STW250-97-2	43.71	41.89	37.94	33.76	41.86	41.86	37.94	33.76	28.16	25.24	20.00	16.44
550C/STW250-118-2	55.05	52.71	47.64	42.13	53.28	52.71	47.64	42.13	37.15	33.75	27.83	20.78
600C/STW250-43-2	14.76	14.55	13.74	12.84	14.02	14.02	13.74	12.84	9.50	8.17	6.00	4.67
600C/STW250-54-2	19.48	19.20	18.08	16.83	18.50	18.50	18.08	16.83	12.85	11.00	8.19	6.45
600C/STW250-68-2	27.64	27.25	25.68	24.12	26.35	26.35	25.68	24.12	17.41	15.12	11.47	9.19
600C/STW250-97-2	44.77	43.92	40.46	36.72	42.44	42.44	40.46	36.72	28.50	25.48	20.31	16.70
600C/STW250-118-2	56.67	55.61	51.17	46.38	54.24	54.24	51.17	46.38	38.11	34.74	28.12	20.94
800C/STW250-43-2	14.77	14.77	14.77	14.41	14.20	14.20	14.20	14.20	9.77	8.45	6.19	4.79
800C/STW250-54-2	19.55	19.55	19.55	19.06	18.80	18.80	18.80	18.80	13.21	11.31	8.38	6.56
800C/STW250-68-2	27.86	27.86	27.86	27.16	26.85	26.85	26.85	26.85	17.80	15.42	11.59	9.21
800C/STW250-97-2	45.50	45.50	45.50	44.07	43.64	43.64	43.64	43.64	28.93	25.60	19.98	16.29
800C/STW250-118-2	58.25	58.25	58.25	56.47	56.24	56.24	56.24	56.24	38.61	34.72	26.97	20.87

Shear Wall Systems

Built-Up Section Axial Load Tables

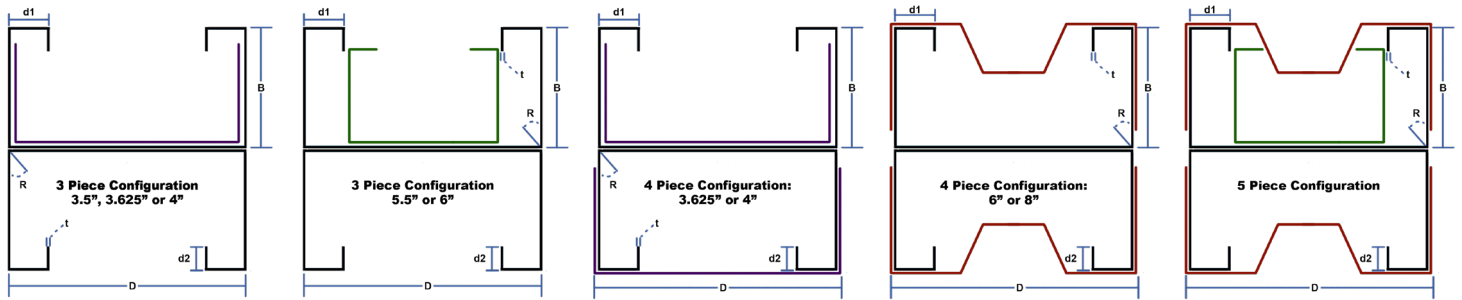

Important Notes

1. Allowable loads are based on specified weak axis and torsional bracing for axial load calculation.
2. Sections are punched with a standard punch-out 1.5" wide located along the centerline of the web 24" o.c.
3. Allowable loads are based on a punched section for axial load calculation.
4. The allowable axial strength for distortional buckling is based on an assumed $k_{\phi} = 0$.
5. Weak axis and torsional bracing should have sufficient stiffness and strength to resist the axial load.
6. Allowable loads for built-up sections are based on maximum attachment interval of 24" o.c. via weld, bolts, or screws.
7. The StiffWall® Column must be used with the StiffWall Boot. Standard (S) will not fit inside the StiffWall Boot or Strap Track.
8. StiffWall Columns are delivered to the job site with Boots pre-attached at the top and bottom for fast installation.

Built-Up Section (Fastener Spacing = 24 in): Axial Compression Load (kips)													
Built-up Section (All 50 ksi)	Thickness	Max Unbraced Length = 48"				Max Unbraced Length = 60"				Max Unbraced Length = Full Height			
		SW Column Height (ft)				SW Column Height (ft)				SW Column Height (ft)			
	(mils)	9	10	12	14	9	10	12	14	9	10	12	14
350C/STW200-97-3P	97 (C/STW), 97 (TP)	28.30	24.66	17.90	13.15	28.30	24.66	17.90	13.15	22.28	18.63	13.23	9.85
350C/STW200-118-3P	118 (C/STW), 97 (TP)	32.73	28.48	20.62	15.15	32.73	28.48	20.62	15.15	26.46	22.24	15.81	11.78
362C/STW200-97-3P	97 (C/STW), 97 (TP)	29.77	26.16	19.36	14.23	29.77	26.16	19.36	14.23	22.41	18.70	13.27	9.88
362C/STW200-118-3P	118 (C/STW), 97 (TP)	34.51	30.30	22.37	16.43	34.51	30.30	22.37	16.43	26.63	22.33	15.87	11.82
362C/STW200-97-3P	97 (C/STW), 97 (TP), 97 (T)	34.97	30.42	22.01	16.17	34.97	30.42	22.01	16.17	27.11	25.03	21.43	16.03
362C/STW200-118-3P	118 (C/STW), 97 (TP), 97 (T)	39.14	33.97	24.49	17.99	39.14	33.97	24.49	17.99	35.38	32.83	24.11	17.99
400C/STW200-97-3P	97 (C/STW), 97 (TP)	34.00	30.54	23.82	17.82	34.00	30.54	23.82	17.82	22.77	18.90	13.41	9.98
400C/STW200-118-3P	118 (C/STW), 97 (TP)	39.64	35.60	27.75	20.75	39.64	35.60	27.75	20.75	27.08	22.58	16.03	11.94
400C/STW200-97-3P	97 (C/STW), 97 (TP), 97 (T)	40.72	36.38	27.89	20.64	40.72	36.38	27.89	20.64	27.62	25.23	21.90	16.69
400C/STW200-118-3P	118 (C/STW), 97 (TP), 97 (T)	45.82	40.88	31.26	23.10	45.82	40.88	31.26	23.10	36.02	33.76	25.06	18.74
550C/STW250-97-3P	97 (C/STW), 97 (S)	56.31	53.63	47.88	41.88	54.17	53.63	47.88	41.88	35.83	32.12	25.39	18.87
550C/STW250-118-3P	118 (C/STW), 97 (S)	67.61	64.39	57.50	50.00	65.66	64.39	57.50	50.00	45.07	40.94	30.35	22.57
600C/STW250-97-3P	97 (C/STW), 97 (S)	58.51	56.13	50.98	45.51	54.89	54.89	50.98	45.51	36.24	32.39	25.43	19.00
600C/STW250-118-3P	118 (C/STW), 97 (S)	70.61	67.77	61.62	55.07	66.75	66.75	61.62	55.07	46.16	41.81	30.57	22.73
600C/STW250-97-3P	97 (C/STW), 97 (SGP)	82.23	79.29	72.57	65.37	74.96	79.29	72.57	65.37	69.98	65.46	56.08	46.68
600C/STW250-118-3P	118 (C/STW), 97 (SGP)	93.87	90.60	82.85	74.52	85.41	90.60	82.85	74.52	79.12	73.79	62.67	51.16
600C/STW250-97-3P	97 (C/STW), 97 (S), 97 (SGP)	95.30	91.40	82.98	74.03	95.30	91.40	82.98	74.03	78.91	73.13	61.30	49.73
600C/STW250-118-3P	118 (C/STW), 97 (S), 97 (SGP)	107.06	102.68	93.19	83.10	107.06	102.68	93.19	83.10	87.87	81.25	67.48	53.84
800C/STW250-97-3P	97 (C/STW), 97 (S)	61.20	61.20	61.20	57.86	57.61	57.61	57.61	57.61	37.47	32.92	24.44	18.74
800C/STW250-118-3P	118 (C/STW), 97 (S)	73.91	73.91	73.91	70.21	70.11	70.11	70.11	70.11	46.78	40.78	30.34	23.26
800C/STW250-97-3P	97 (C/STW), 97 (SGP)	92.13	92.13	92.13	87.36	83.63	83.63	83.63	87.36	79.69	74.74	64.44	54.09
800C/STW250-118-3P	118 (C/STW), 97 (SGP)	104.69	104.69	104.69	99.52	94.95	94.95	94.95	99.52	89.60	83.80	71.77	59.76
800C/STW250-97-3P	97 (C/STW), 97 (S), 97 (SGP)	107.85	107.85	107.49	100.93	97.96	97.96	107.49	100.93	89.91	83.62	70.70	57.98
800C/STW250-118-3P	118 (C/STW), 97 (S), 97 (SGP)	120.37	120.37	120.36	113.07	109.22	109.22	120.36	113.07	99.58	92.41	77.72	63.32

Boot Dimensions And Thickness

StiffWall® Boots are designed to provide the optimal cost-effective solution for shear wall connections. Six configurations are available to meet project requirements (Light, Plus, Small, Medium, Transition and Large). StiffWall Boots are sized to fit inside standard track and are available for 3.5", 3.625", 4", 5.5", 6" and 8" Depths. **During installation of StiffWall Boots, standard or plate washer shall be used with a size sufficient to cover the Boots' slots after installation.** Light and Plus Boots are used with single StiffWall column only. The Steel Network will fabricate the StiffWall columns to the required height (adjacent stud cut height or other height provided by the contractor). StiffWall columns are delivered to the job site (or requested location by the contractor) with Boots pre-attached at the top and bottom of columns for fast installation.

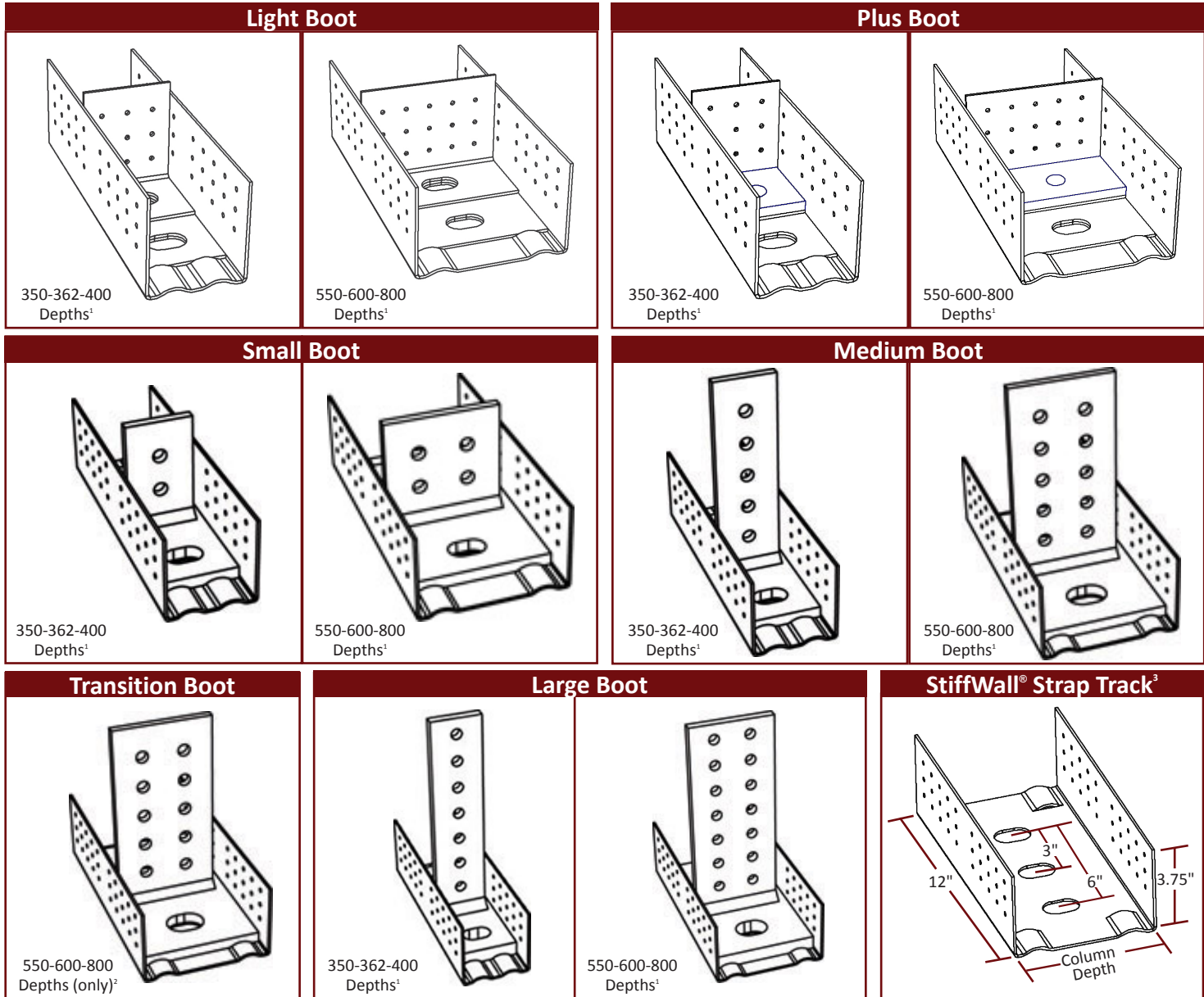

¹ Boots less than or equal to 4" and Light, Plus and Medium Boots greater than 4" contain guide holes for 7/8" anchors. Transition and Large Boots greater than 4" contain guide holes for 1 1/4" anchors.

² The StiffWall Transition Boot is used when the floor above uses a Small or Medium Boot and the floor below uses a Large Boot (for depths greater than 4" only). The anchor hole of the Transition Boot at the base of the wall couples with that of the Large Boot at the underside of the floor below to maintain the continuity of the through-floor fasteners (1 1/4" threaded rods or anchors).

³ StiffWall Strap Track is available in 12ga (97mils) thickness. Center hole is for conditions where only one anchor is necessary

Subtract Boot Thickness to Determine Column Bearing Height

The Steel Network will determine the actual bearing height of a StiffWall Column by subtracting the thickness of the StiffWall Boot and Strap Track elements on which it is bearing. For each boot, the Strap Track is 97mils thick. The dimensions of various boot elements are shown in the table below. Contact TSN for design recommendations or assistance with any light steel framing technical issue.

Boot Type	Strap Track Thickness	Base Plate Thickness	Additional Base Plate Thickness	Total Thickness of Two Boots ¹
Light, Plus	0.1017"	0	0.1242"	0.5"
Small, Medium, Transition	0.1017"	0.5"	0	1.3125"
Large	0.1017"	0.75"	0	1.8125"

¹ Total thickness rounded to nearest 1/32", with 1/32" added for installation tolerance.

Material Composition

Cold-Formed Steel: ASTM A 1003/A 1003M, ST50H or equivalent (Min. $F_y = 50$ ksi, Min. $F_u = 65$ ksi).

Structural Steel: ASTM A 572/A 572M, Grade 50 or equivalent (Min. $F_y = 50$ ksi, Min. $F_u = 65$ ksi).

Coating Powder – Black or TSN approved equivalent.

Bolts: ASTM F3125 Grade A325.

Important Notes

1. Allowable loads are based on analysis of loads and allowable stresses set by AISI S100 and AISC 360 Spec.
2. Straps tension T1 is the summation of tension forces in the the two diagonal straps.
3. Load paths for straps tension and column uplift are independent in the boot connection and allowable loads T1 and T2 can be combined for the same boot.
4. Check combined tension and shear in anchor bolts due to applied T1 and T2 values as per AISC 360 Specification, Sec. J3.7.
5. Check screw shear for T2 on Light and Plus boot connection to column. Factory-assembled kits come with 4 #12 screws by default. Up to 11 more screws can be added as specified by designer.
6. Allowable loads for wall aspect ratio other than listed can be interpolated, but not extrapolated.
7. Fillet Weld Designation is E70XX Metal Arc or equivalent. Thickness as specified.
8. Consider the provisions of AISI S400-20 in the design of connections when designing the lateral system in buildings assigned to Seismic Design Category (SDC) D, E, or F, or wherever the Seismic Response Modification Coefficient "R" used to determine the seismic design forces is greater than 3.

Load Direction Diagram

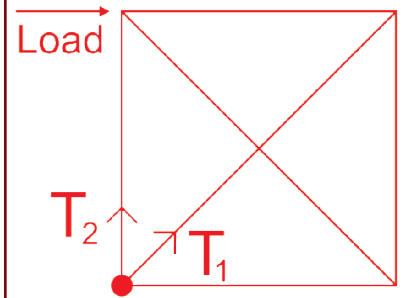

If load capacities exceed published loads, custom boot connections may be manufactured. Contact TSN for recommendations.

StiffWall® Boot Capacity (kips)									
Width (in)	Wall	Light		Plus		Small / Medium / Transition		Large	
	Aspect Ratio	Straps Tension	Column Uplift	Straps Tension	Column Uplift	Straps Tension	Column Uplift	Straps Tension	Column Uplift
	Vertical: Horizontal	T1	T2	T1	T2	T1	T2	T1	T2
3.5	0.6:1 (30.96 deg.)	12.00	1.78	12.75	4.79	18.60	8.65	18.60	19.46
	1:1 (45 deg.)	8.73	1.78	15.47	4.79	22.08	8.65	22.08	19.46
	2:1 (63.5 deg.)	6.91	1.78	12.38	4.79	26.81	8.65	29.01	19.46
3.625	0.6:1 (30.96 deg.)	11.59	1.83	12.75	4.98	18.60	8.98	18.60	20.21
	1:1 (45 deg.)	8.43	1.83	15.12	4.98	22.08	8.98	22.08	20.21
	2:1 (63.5 deg.)	6.67	1.83	11.95	4.98	25.88	8.98	29.01	20.21
4	0.6:1 (30.96 deg.)	10.50	1.97	12.75	5.56	18.60	9.98	18.60	22.46
	1:1 (45 deg.)	7.64	1.97	13.70	5.56	22.08	9.98	22.08	22.46
	2:1 (63.5 deg.)	6.04	1.97	10.83	5.56	23.46	9.98	29.01	22.46
5.5	0.6:1 (30.96 deg.)	7.64	2.49	12.75	7.86	18.60	13.98	21.48	35.76
	1:1 (45 deg.)	5.56	2.49	9.96	7.86	21.58	13.98	25.34	35.76
	2:1 (63.5 deg.)	4.39	2.49	7.88	7.86	17.06	13.98	32.23	35.76
6	0.6:1 (30.96 deg.)	7.00	2.65	12.55	8.62	18.60	15.32	21.48	39.16
	1:1 (45 deg.)	5.10	2.65	9.13	8.62	19.78	15.32	25.34	39.16
	2:1 (63.5 deg.)	4.03	2.65	7.22	8.62	15.64	15.32	32.23	39.16
8	0.6:1 (30.96 deg.)	5.25	3.21	9.41	11.69	18.60	20.65	21.48	52.80
	1:1 (45 deg.)	3.82	3.21	6.85	11.69	14.84	20.65	25.34	52.80
	2:1 (63.5 deg.)	3.02	3.21	5.42	11.69	11.73	20.65	25.81	52.80

Boot Components

StiffWall Boots come pre-assembled with StiffWall Columns. Please refer to the StiffWall product page for full system design and order information. Contact TSN technical support for design recommendations.

Please Note: Boot Kits may NOT be sold separately, as they are part of an engineered system.



StiffWall Base Plate



A325 Column Bolts

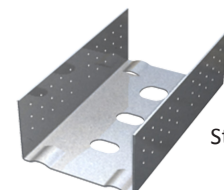

Strap Track

Sample Structure

The following example is used to illustrate the design capabilities of The Steel Network's StiffWall® SWS system as a shear panel to resist lateral loads. The information contained within this catalog shows the step by step design process used to design TSN's StiffWall.

Certain assumptions are made within the catalog and the example problem. All analyses are shown for example only and do not replace building code specific loading requirements and/or load combinations. Please contact The Steel Network for further information.

The example utilizes StiffWall in the construction of a 5-story building structure. Loads and reactions at each story have been provided as well as overall foundation reactions for anchorage design. Service wind loads and ASD design method are used. Two load cases were examined:

- (1) Dead + 0.6 In-plane Wind, (D + 0.6W)
- (2) Dead + 0.75 Live + 0.45 In-plane Wind, (D + 0.75L + 0.45W)

Important Design Considerations:

- D + W load combination is the controlling combination in this example. The wall depth is chosen as 6 inches.
- Uplift and tension loads in StiffWall columns are calculated with a tributary width from the dead load = 5 ft. (about 1/2 of panel width). Compression loads in StiffWall columns are calculated with a tributary width from dead load equal to stud spacing = 2 ft.
- End columns are designed as unbraced full height in the lateral and torsional directions under compression forces. Otherwise, if bracing is considered, it must be adequately designed for bracing force. See bridging data for details of lateral bracing calculations.
- Back-to-back end columns are designed to be attached together at 24 inch max. o.c.
- StiffWall does not substitute for floor rigidity. Sufficient diaphragm stiffness or an additional horizontal compression member is required to transfer the load.
- Floor summaries on the next page refer to the design steps previously given (pages titled StiffWall® SWS Design). Step 5 is designed by others.
- f'_c of foundation concrete = 4,000 psi.

Assumptions

- Stud Spacing = 24 inch o.c.
- Dead Load = 0.5 kips/ft.
- Live Load = 0.75 kips/ft.
- Tributary Width = 2.0 ft. for Compression check; 5 ft. for Uplift check
- D + 0.6W load combination checked
- D + 0.75L + 0.45W load combination checked

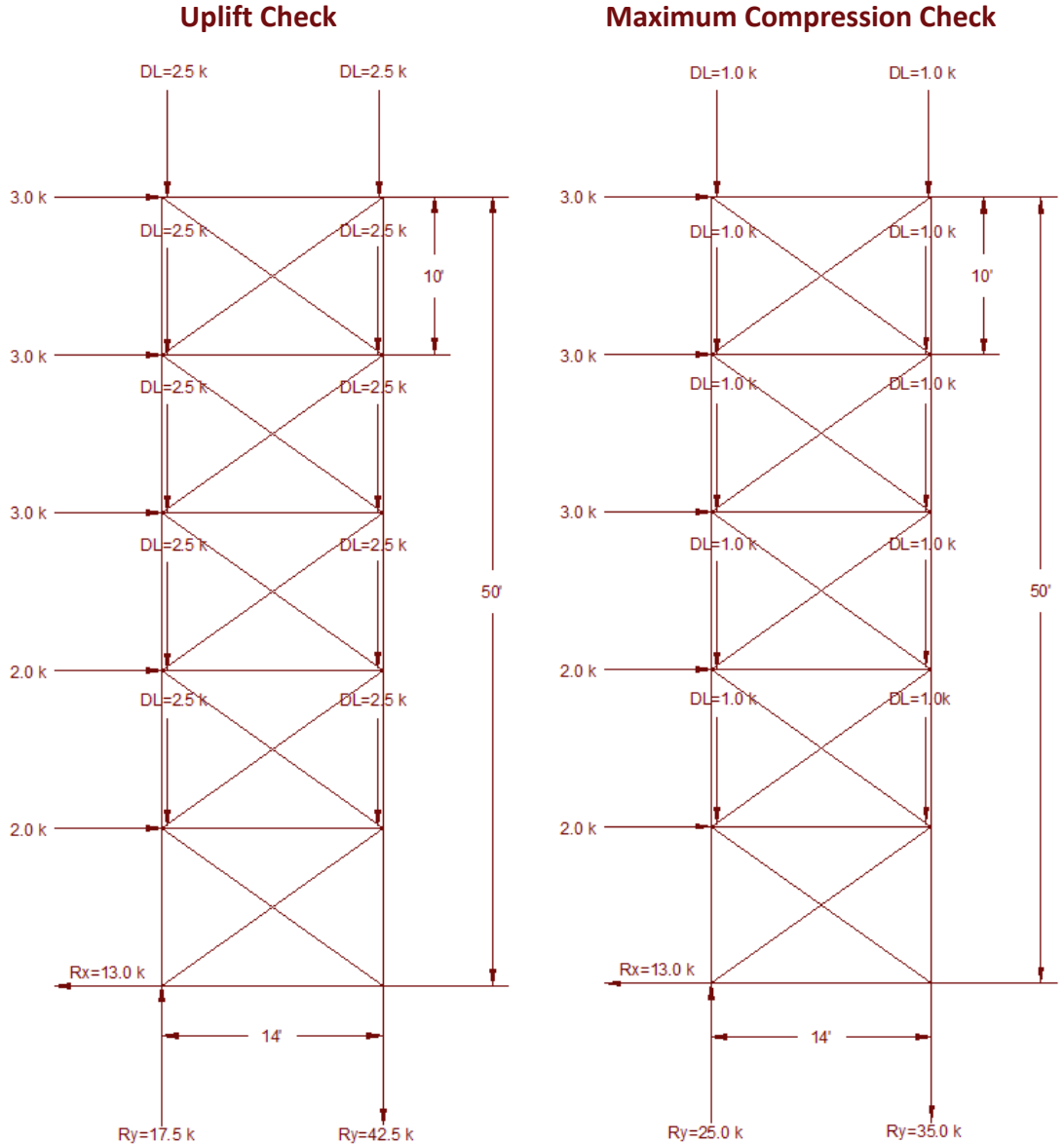

Uplift Check

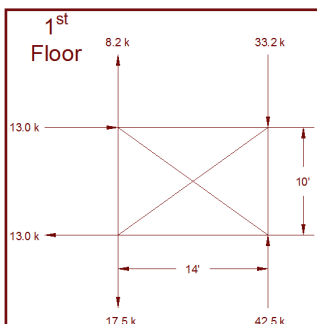
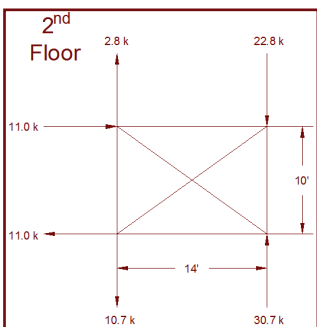
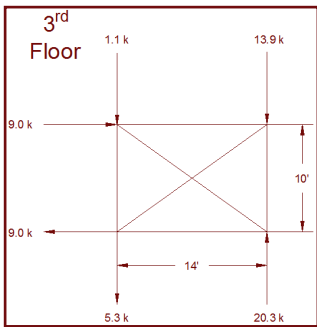
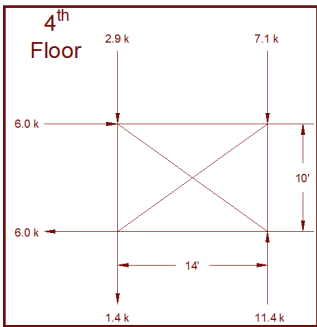
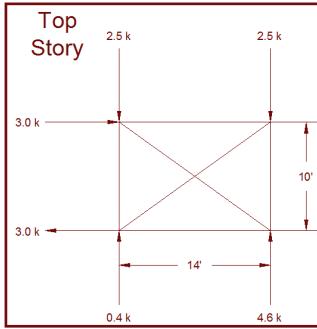

Loads on Top Floor Shear Wall From Analysis:

1. Column compression = 3.1 kips. No tension in column
• Use 600C/STW250-54-1 with allowable capacity = 3.5 kips > 3.1 kips
2. Use StiffWall Light Boot with T1 capacity of 6.5
3. Attach StiffWall Light Boot to column using (4) #12 screws
4. The tension in the flat strap is: 3.7 kips in 2 straps:
• Use (2) 4" x 54mil straps with capacity = 11.5 kips > 3.7 kips
• Use (6) #12 screws each strap each Strap Track with capacity = 6.8 kips > 3.7 kips
5. No uplift in through-floor connection, shear = 3.0 kips
• Use One 3/8" A325 bolt through floor

Loads on 4th Floor Shear Wall From Analysis:

1. Column compression = 8.4 kips. No tension in column
• Use 600C/STW250-118 with allowable capacity = 10.7 kips > 8.4 kips
2. Use StiffWall® Plus Boot with T1 capacity = 11.6 kips
3. Attach StiffWall® Plus Boot to column using (4) #12 screws
4. The tension in the flat straps is: 7.4 kips in 2 straps:
• Use (2) 4" x 54 mil straps with capacity = 11.5 kips > 7.4 kips
• Use (7) #12 screws each strap to Strap Track with capacity = 8.0 kips > 7.4 kips
5. Uplift in through-floor connection = 1.4 kips, shear = 6.0 kips
• Use One 3/8" A325 bolt through floor
• Use (2) 3/8" A325 bolts at base to connect to Small Boot below

Loads on 3rd Floor Shear Wall From Analysis:

1. Column compression = 15.8 kips. No tension in column
• Use 600C/STW250-97-2 with allowable capacity = 25.5 kips > 15.8 kips
2. Use StiffWall Small Boot with T1 capacity = 18.9 kips
3. Attach StiffWall Small Boot to column using (4) 1/2" A325 bolts
4. The tension in the flat straps is: 11.1 kips in 2 straps:
• Use (2) 4" x 54 mil straps with capacity = 11.5 kips > 11.1 kips
• Use (10) #12 screws each strap to Strap Track with capacity = 11.4 kips > 11.1 kips
5. Uplift in through-floor connection = 5.3 kips, shear = 9.0 kips
• Use (2) 3/8" A325 bolt through floor

Loads on 2nd Floor Shear Wall From Analysis:

1. Column compression = 24.7 kips.
• Use 600C/STW250-97-2 with allowable capacity = 25.5 kips > 24.7 kips
2. Column tension = 2.8 kips*
• Use StiffWall Small Boot with T1 capacity = 18.9 kips & T2 capacity = 15.3 kips
3. Attach StiffWall Small Boot to column using (4) 1/2" A325 bolts
• Capacity of (4) 1/2" A325 bolts to (2) 97 mil columns = 21.2 kips > 2.8 kips
4. The tension in the flat straps is: 13.5 kips in 2 straps:
• Use (2) 6" x 54 mil straps with capacity = 17.3 kips > 13.5 kips
• Use (12) #12 screws each strap to Strap Track with capacity = 13.7 kips > 13.5 kips
5. Uplift in through-floor connection = 10.7 kips, shear = 11.0 kips
• Use (2) 3/8" A325 bolt through floor

* Uplift calculated using 5 ft. tributary width and dead load used to offset uplift at the tension side of the wall.

Loads on 1st Floor Shear Wall Loads From Analysis:

1. Column compression = 35.0 kips
• Use 600C/STW250-118-2 with allowable capacity = 34.7 kips ≈ 35.0 kips
2. Column tension = 8.2 kips*
• Use StiffWall Small Boot with T1 capacity = 18.9 kips & T2 capacity = 15.3 kips
3. Attach StiffWall® Small Boot to column using (4) 1/2" A325 bolts
• Capacity of (4) 1/2" A325 bolts to (2) 118 mil columns = 21.2 kips > 8.2 kips
4. The tension in the flat straps is: 16.0 kips in 2 straps:
• Use (2) 6" x 54 mil straps with capacity = 17.3 kips > 16.0 kips
• Use (15) #12 screws each strap to Strap Track with capacity = 17.1 kips > 16.0 kips
5. Anchorage uplift = 17.5 kips, shear = 13.0 kips
• Use (2) 3/8" Hilti HIT-HY 200 Adhesive Anchors, HAS Super ASTM A193 B7, Embedment depth = 10.5 inches; check additional tension from prying action.

* Uplift calculated using 5' tributary width and dead load used to offset uplift at the tension side of the wall.

Max. Compression Check

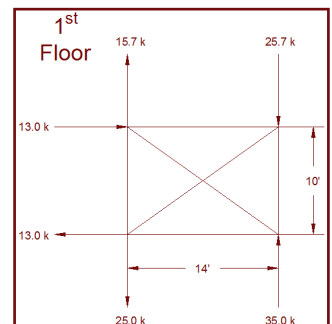
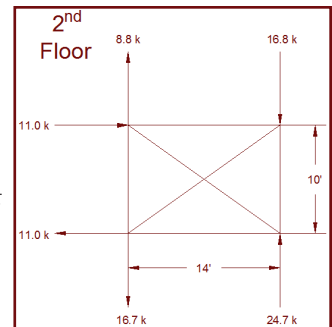
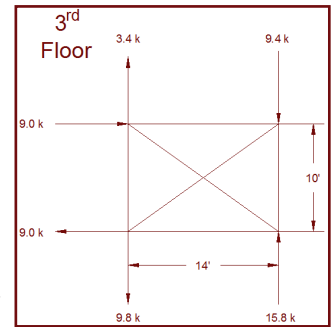
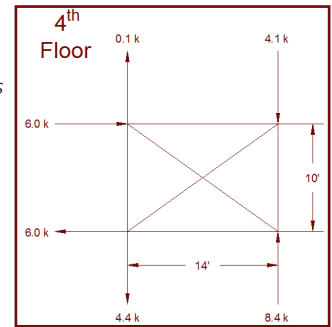
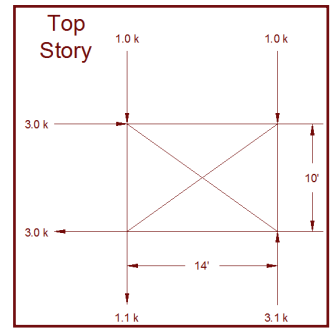

StiffWall® SWS Schedule					
Wall #	StiffWall® Column & Boot Section	Strap Bracing (50ksi)	Column Connection to Boot	Strap Track #12 Screws (Each Side)	Floor/Anchorage Connection
SW-5	600C/STW250-54-1-LT	(2) 4" x 54 mil	(4) #12 Screws	6	(1) 7/8" Bolt
SW-4	600C/STW250-118-1-PL	(2) 4" x 54 mil	(4) #12 Screws	7	(1) 7/8" Bolt, (2) at base
SW-3	600C/STW250-97-2-SM	(2) 4" x 54 mil	(4) 1/2" A325 Bolts	10	(2) 7/8" Bolt
SW-2	600C/STW250-97-2-SM	(2) 6" x 54 mil	(4) 1/2" A325 Bolts	12	(2) 7/8" Bolt
SW-1	600C/STW250-118-2-SM	(2) 6" x 54 mil	(4) 1/2" A325 Bolts	15	(2) 7/8" Hilti HIT-HY 200 Adhesive Anchors

Typical Detail, StiffWall® SWS Back-to-Back Column at SW-2 Above

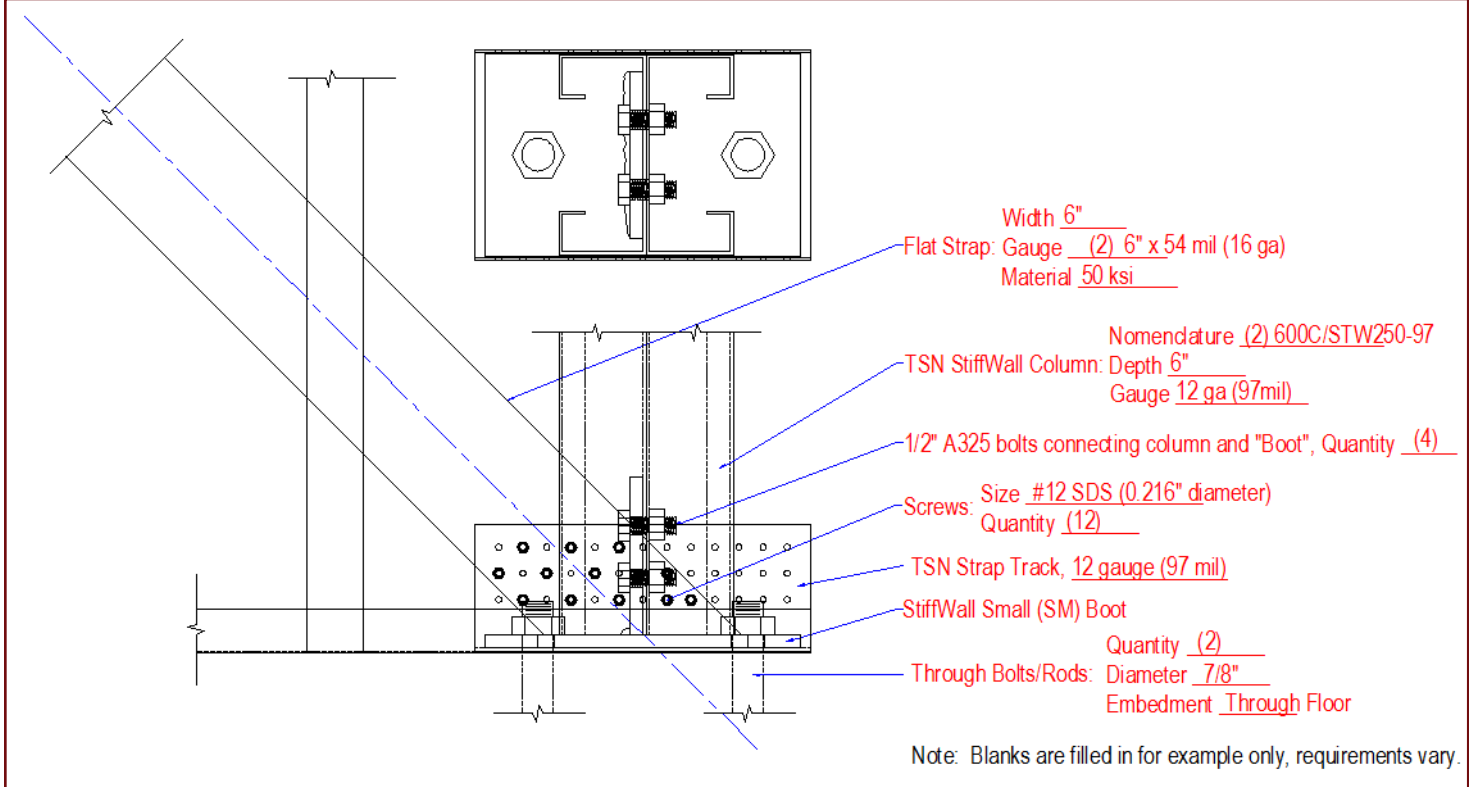



Material Properties

A1003 / A1003M ST50H [ST340H], Grade 50 (340), 50ksi (340MPa) minimum yield strength, 65ksi (450 MPa) minimum tensile strength, G-60 (Z180) hot-dipped galvanized coating; or equivalent.

Flat Strap Product Profile (For StiffWall®)						
Section	Width (D)	Gauge	Design Thickness (t)	Min. Steel Thickness ($t_{(min)}$)	Area	Weight
	(in)		(in)	(in)	(in ²)	lbs/ft
FS400-54, 50 ksi	4	16	0.0566	0.0538	0.226	0.770
FS600-54, 50 ksi	6	16	0.0566	0.0538	0.340	1.156
FS800-54, 50 ksi	8	16	0.0566	0.0538	0.453	1.541
FS800-68, 50 ksi	8	14	0.0713	0.0677	0.570	1.941
FS1000-68, 50 ksi	10	14	0.0713	0.0677	0.713	2.426
Flat Strap Product Profile (For Bridging)						
FS200-43, 50 ksi	2	18	0.0451	0.0428	0.090	0.307
FS300-43, 50 ksi	3	18	0.0451	0.0428	0.135	0.460
FS300-54, 50 ksi	3	16	0.0566	0.0538	0.170	0.578

Table Notes:

- Section properties and capacities are calculated in accordance with AISI S100.
- Structural framing is produced to meet or exceed ASTM A653 and A1003.
- Non-Structural framing is produced to meet or exceed ASTM C645, A653, and A1003.
- Galvanized sheet steel meets or exceeds requirements of ASTM A924 & A1003.

Order Information for StiffWall Flat Strap

The Selection of flat strap for StiffWall® is simplified to 6 strap types, with load capacity factored using standard 12ga (97mil) strap track (see Step-By-Step Design Procedure on TSN's StiffWall product page for Allowable Flat Strap Capacity Chart). Flat Strap is cut to length with square ends, and will need to be cut to final length in the field. To determine the length of the flat straps, follow these simple steps:

1. Find the width (A) and the height (B) of the StiffWall.
2. Then, use the following formula to determine the length of the strap: $A^2 + B^2 = C^2$
3. Next, take the square root of C, round up to the nearest whole number and add 1

This will result in a length in feet that you can work with. If C equals a whole number, you may want to add 2 to make sure the length is enough.

Example: 8' wall height with a width of 16' would look like this: $(8 \times 8) + (16 \times 16) = \sqrt{320} = 17.88$
Round up to 18' and add 1' for a strap length of 19'.

Some points to remember concerning Flat Strap:

- Strap must be pulled tight after a gravity load above has been applied. TightStrap® tool can be used to flatten the strap and put minor tension force into it.
- Flat strap cannot be installed, then un-installed by releasing the screws to the strap track, and then re-installed with screws again in the same screw holes. Either a new piece of strap is required, or the exposed edge of the strap needs to be welded to the strap track with an approved weld design.
- It is recommended not to fasten the strap to the infill studs between the columns. However, typical or occasional attachment of sheathing and/or resilient channel to the infill studs through the strap is acceptable.
- Straps should not be spliced without an approved design.
- Four (4) pieces of strap are required in each StiffWall (If there are 10 StiffWall shear walls, 40 pieces of flat strap will be necessary).

Product Description

The pre-tensioning of a shear wall flat strap provides a means to ensure the shear wall will perform as designed. It is important that the flat straps are as tight as possible when installed to achieve optimal system performance.

TightStrap® is a unique device used to tension (tighten) flat strap in the field. Use TightStrap to improve structural performance of a shear wall by removing “waviness” or “bowing” prior to fastening.

TightStrap is designed to be used in both StiffWall® and generic flat strap shear walls. TightStrap’s track connector fastens to standard track at the corners of the shear wall to provide a base for the tensioning process. It is preferable to tighten the flat straps after applying some vertical load (own weight) on top of the shear wall panel.

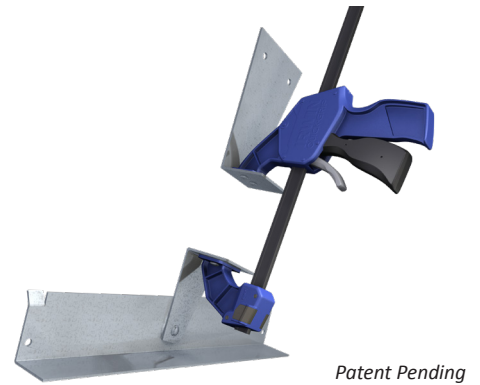

Using TightStrap®

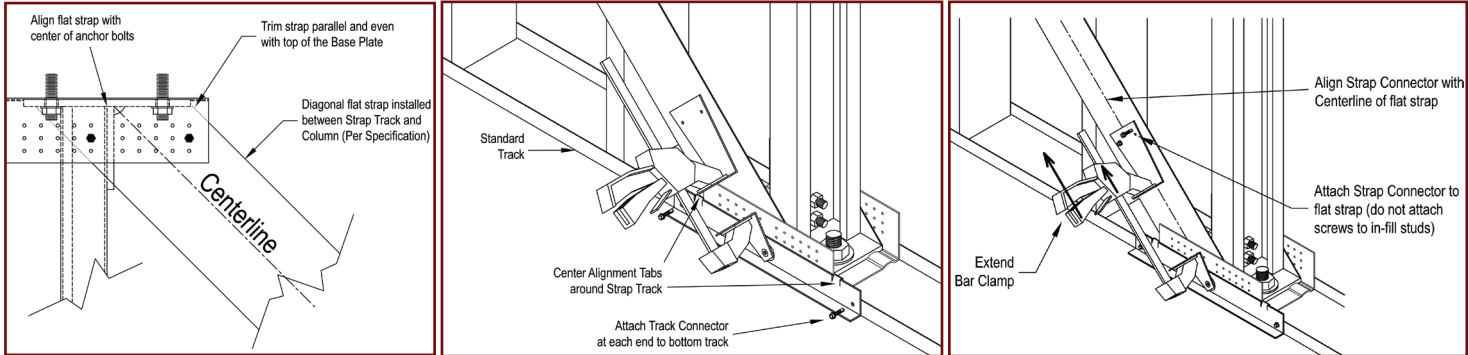

Step 1 - Align & trim flat strap at each corner, attach one end with at least 2 screws.

Step 2 - Align Track Connector and attach to track.

Step 3 - Extend Bar Clamp, align Strap Connector with centerline of flat strap and attach Strap Connector to the flat strap.

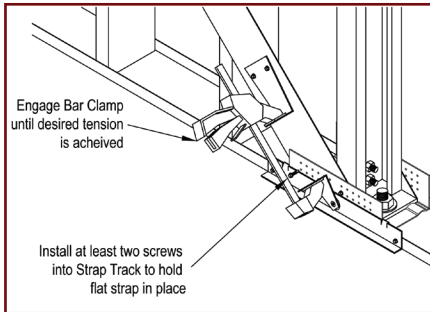

Step 4 - Engage Bar Clamp, install at least 2 screws for flat strap attachment, remove TightStrap and install remaining screws for strap attachment.

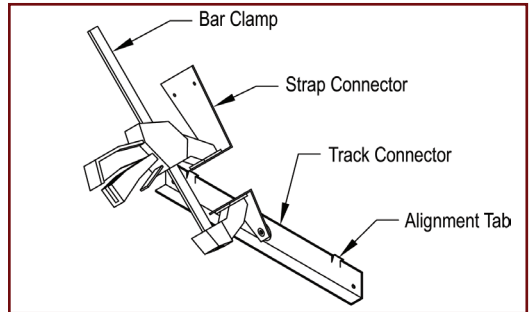

How to Install the StiffWall® Shear Wall:

The boots are attached to the foundation or floor and the roof or ceiling with approved anchors or bolts as determined and approved by the Engineer (Boots are made up of the Strap Track and the “T” shaped Base Plate)

- Light, Plus, Small & Medium Boots utilize a 3/8” anchor bolt or threaded rod.
- Transition and Large Boots utilize a 3/8” anchor bolt or threaded rod on boots less than or equal to 4”. Boots greater 4” contain guide holes for 1 1/4” anchor bolt or threaded rod.
- Attach the Flat Strap to the Strap Track, corner to corner, on both sides (4 straps needed) with the specified amount of #12 screws (or weld). The use of low profile screws help to reduce a “bump out” of finished sheetrock. To achieve the designed loads, the strap should be tight from corner to corner (with no slack). This is done by tightening the strap after the wall is loaded with a TightStrap® tool.

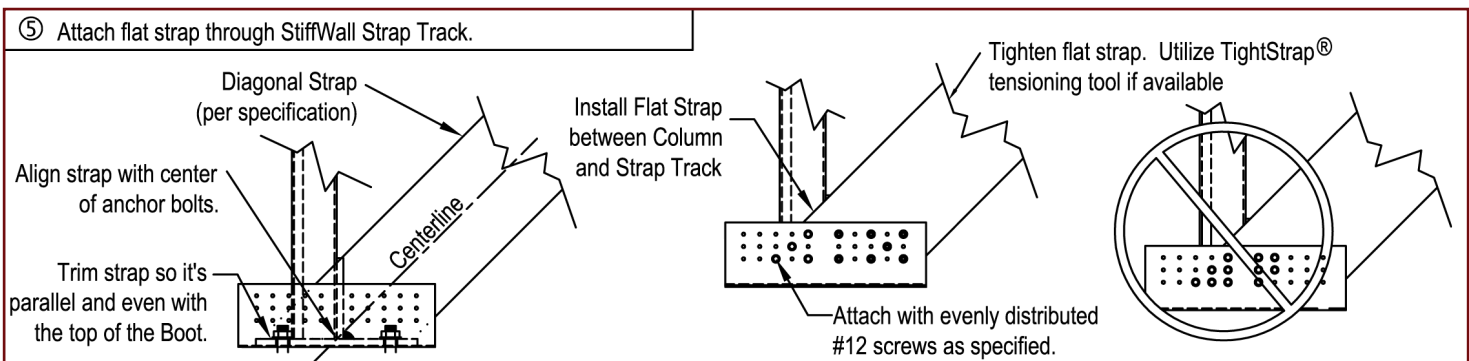

StiffWall® Placement in Load Bearing Wall

StiffWall is usually not designed as a gravity load bearing element. However, its boundary end columns can see compression loads from the floor weight above. This system is designed to sit in between load bearing studs and address all of the lateral loads acting on that building due to wind or earthquakes.

The StiffWall is designed to stack vertically and attach through the floor system to the level above (Fig. 1). The Columns for one floor must line up with the columns on the floors above and below. This will allow for the bolts from one floor to be bolted through the floor system to the boots above and/or below. It is important that these bolts are properly aligned through each floor for the walls to be able to work together as one unit from top to bottom. Do not enlarge the anchor holes in the StiffWall Boots.

It is recommended that StiffWall boundary end columns have axial compression capacity greater than or equal to the typical load bearing stud within the wall.

Attachment of Sheathing to the StiffWall® Column

Since the StiffWall assembly is installed within the thickness of the top and bottom tracks, sheathing should not be attached directly to the StiffWall Column. The thickness of the strap track on either side of the wall (97mils [12ga]) reduces the depth of the StiffWall Column within the assembly (Fig. 2). As a result, if the sheathing is attached to the StiffWall Column, a level plane will not occur along the wall. Attach the sheathing to the infill studs bordering the StiffWall columns.

Vertically Stacking Shear Walls

StiffWall shear walls transfer loads concentrically from the floor element above to the floor element below. The StiffWall system should consist of vertically stacked panels to effectively transfer lateral forces to the foundation (Fig. 3). Any eccentricity in the system negatively effects the load distribution to the StiffWall components. The vertical alignment of the walls is critical for the through-floor connections. Coordinate installation to ensure through-floor connectors align with StiffWall Boots on the floors above and below.

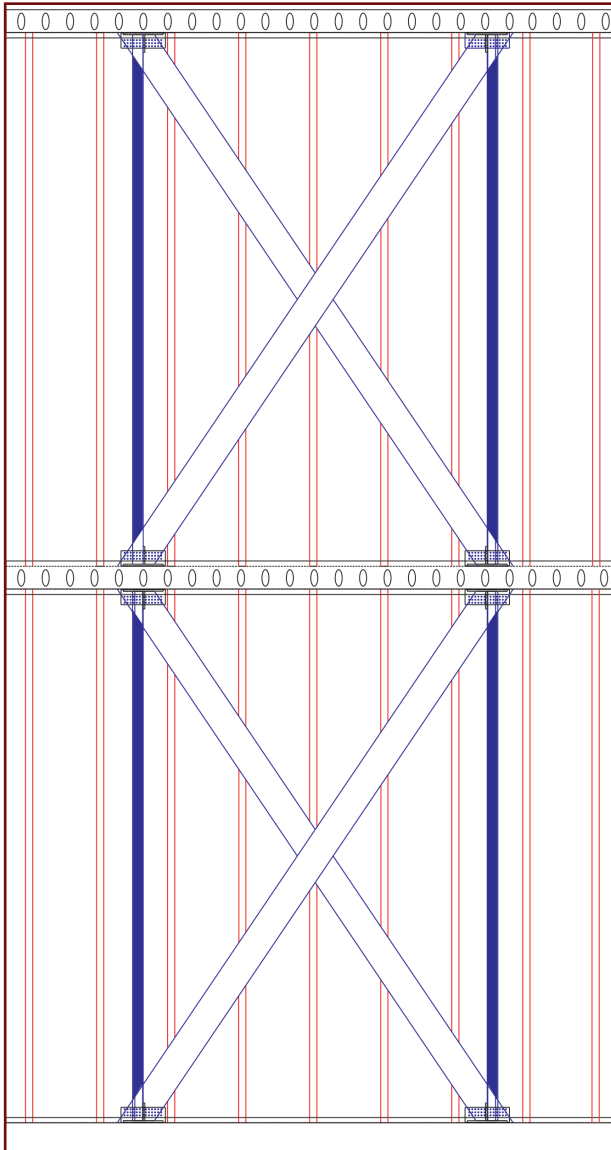

Fig. 1: StiffWall Column/Boot Assembly (blue line) is placed within the spacing of the SigmaStud® (in red).

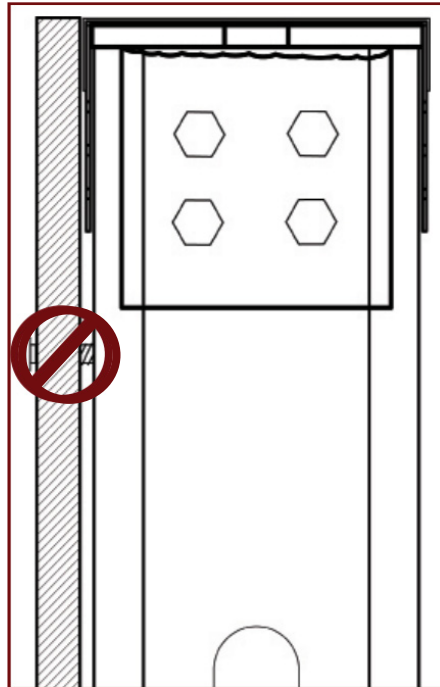

Fig. 2: Sheathing should not be attached directly to the StiffWall Column. Attach the sheathing to the adjacent studs.

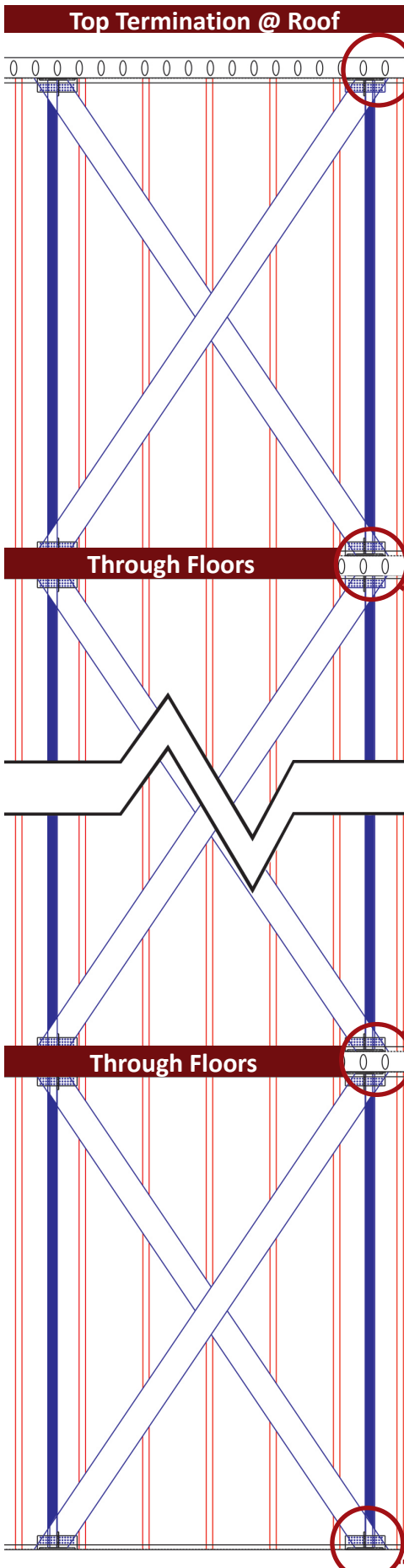

Fig. 3: Shear walls should be stacked vertically.



Shear Wall Systems

Example Details



Top Termination @ Roof

Hollow Core Slabs

Light Steel Framing

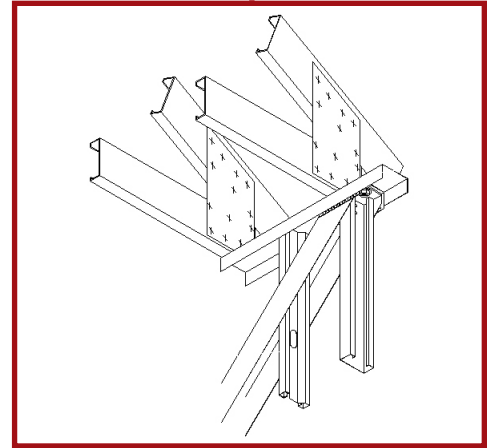
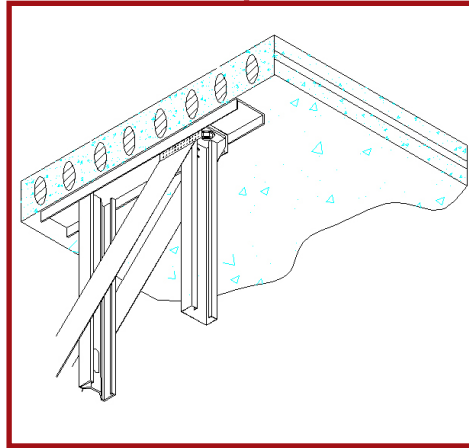

Through Floors

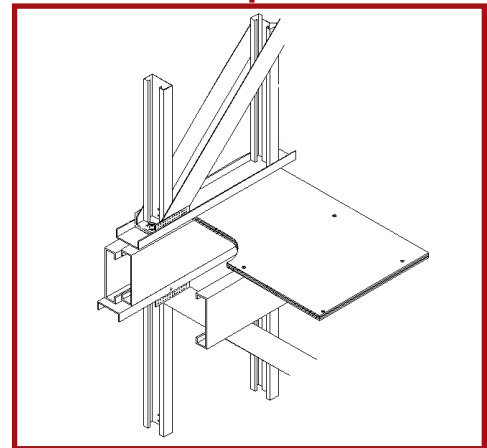
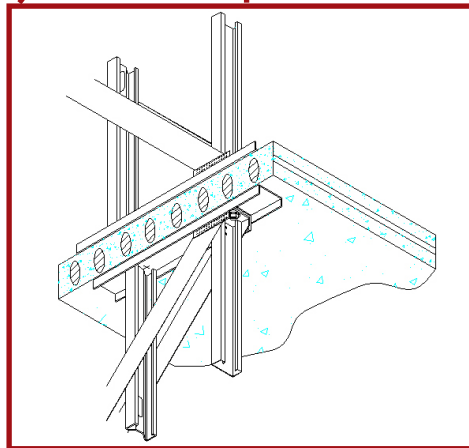

Through Floors

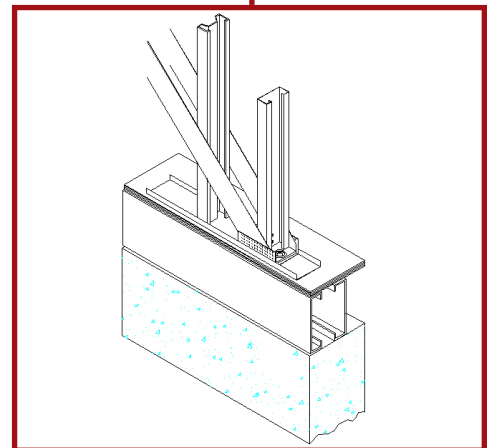
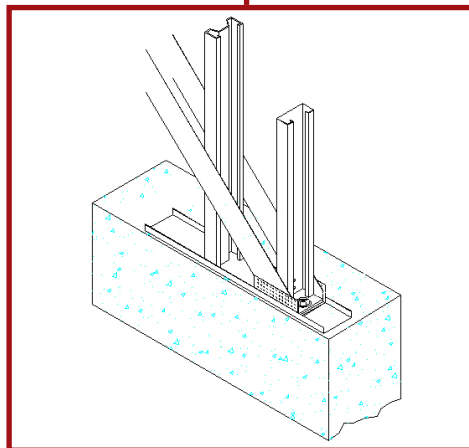

Hold Down To Foundation

Floor Systems Appropriate for Cold-Formed Steel Load Bearing Construction

Several types of floor systems can be integrated with cold-formed steel stud load bearing walls. Among these floor systems are the composite steel deck-concrete slab, composite bar joist with concrete on metal deck or structural panel floor diaphragm, hollow core concrete planks or cold-formed steel joist with concrete on metal deck or structural panel floor diaphragm. This section provides a short introduction to these floor systems.

Composite steel deck-concrete slabs combine the structural advantage of a flat slab with the time saving advantage of a permanent form. The steel deck furnishes the total bottom reinforcement of the composite slab, while additional top reinforcement is required. Due to the composite action between the concrete and the steel deck, the slab can support a greater floor live load than a typical reinforced concrete slab of the same depth. The steel deck is typically spot-welded to the top track of the wall panel.

Composite bar joist with concrete on metal deck or structural panel floor diaphragm enables clear spans for 10 to 24 inch deep system. The metal deck provides permanent form and tension reinforcement, and the concrete slab thickness is typically about 2½" on top of deck. This system necessitates in-line framing between the joists and the wall studs to ensure transfer of gravity loads to the wall studs without eccentricity.

Precast hollow core concrete slabs provide the advantages of rapid field installation. The planks are typically produced in 6, 8, 10, 12, and 16 inch depths. The hollow core floor system provides long design spans compared to other systems meeting the requirements of cold-formed steel load bearing construction. However, factors such as concentrated loads and large openings can affect the span capabilities of the system. Sound Transmission Class (STC) rating and fire resistance rating typically meet the most stringent design criteria.

Cold-formed steel joist with concrete on metal deck or structural panel floor diaphragm is a non-composite system that is significantly lighter than all other floor systems. The joists are typically 8 to 16 inches deep. Relatively sizeable cold-formed steel joists (97 mils thick, and 14 inches deep) can accommodate clear spans up to 30 ft. Cold-formed steel joists require lateral bracing, or blocking, to prevent lateral torsional buckling, and may require end and intermediate bearing stiffeners to prevent web crippling.



Composite Steel Deck



Pre-Cast Hollow Core Slab

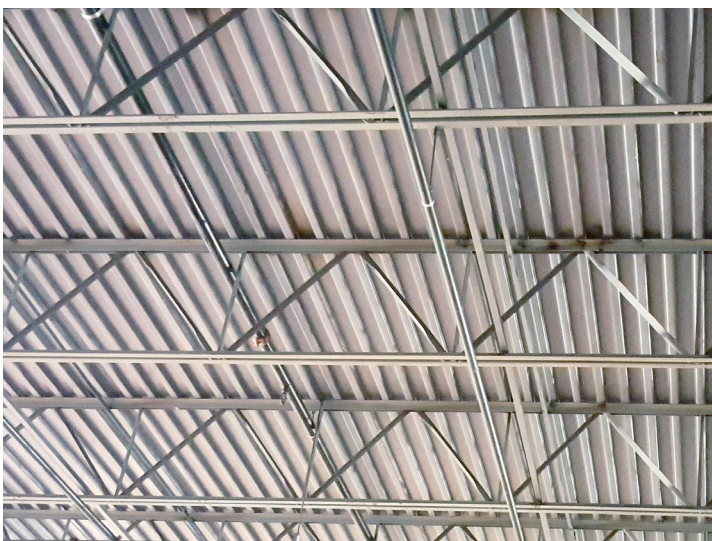

Composite Bar Joist



Cold-Formed Steel Joist

1200PJ 350-68, 50 ksi

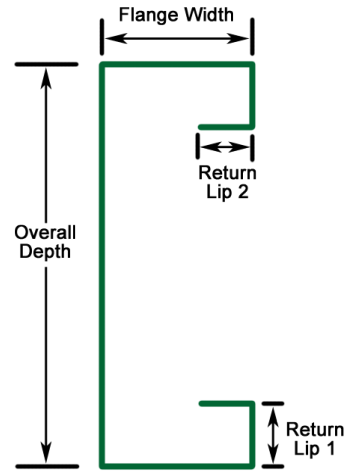

Background

PrimeJoist is a revolutionary addition to the light gauge steel stud industry, producing significant economies in both design and installation when compared with conventional “C” Shaped studs. PrimeJoist’s unique configuration delivers increased strength and stiffness, minimizing or eliminating the use of built-up joist sections in floor assemblies. Available in all common floor joist depths, PrimeJoist streamlines the design and construction process. PrimeJoist’s shape is easily differentiated from the typical c-shape, enabling the selection of the most optimal member sizes to fit project conditions. ASI’s SteelSmart® System software includes the complete database of sections to quickly design PrimeJoist floor joists and connections. Visit www.steelSMARTsystem.com for your copy today!

PrimeJoist® Section

Benefits That Add Value:

Quality

- Increases load capacity over a standard “C-shaped” stud of the same thickness, reducing overall materials needed
- Increased stiffness for deflection
- Increased load capacity enables selection of optimal thickness of flooring members

Value

- Simplified joist and floor system design
- Lighter weight results in shipping efficiencies and easier handling
- Provides a flat surface for attachment of door or window frame, requiring no additional track
- No welding or fastening built-up members together



Introduction

Fire-resistance ratings have long been used by UL and the building codes to measure the performance of building components or assemblies in a fire situation. Fire-resistance rating of a floor system classifies the ability of the floor assembly to confine and isolate fire within a zone comprised of the assembly. The ratings are obtained from fire tests designed to determine the time it takes for a fire to raise the temperature to unacceptable levels. Building codes require fire resistance ratings that are based on laboratory testing done in accordance with ASTM E119: Standard Test Methods for Fire Tests of Building Construction and Materials.

Sound Transmission Class (STC) of a floor system measures the ability of the floor assembly to block airborne sound transmission. STC is reported as a numerical value, and higher values represent a better ability to block airborne sounds. STC can be measured through a laboratory test which is based on ASTM E90, or a field test that is based on ASTM E413.

Impact Insulation Class (IIC) of a floor system measures the ability of the floor assembly to block impact sound transmitted through the assembly and structure. Impact sound transmission arises from a variety of sources, most notably the movement of people within a building. Like STC values, IIC also is reported as a numerical value, and higher values represent less sound transmission. The procedure for the IIC test is defined in ASTM E492 and E989.

Fire-resistance rated floor assemblies are identified in the UL Fire Resistance Directory, and can be found at the Underwriters Laboratories website at ul.com. Data for STC and IIC can be found for some assemblies through specific publications such as “A Guide to Fire and Acoustic Data for Cold-Formed Steel Floor, Wall & Roof Assemblies” by the Steel Framing Alliance. This section presents sample rated floor assemblies from this publication.

UL G549 Fire Resistance Rating: 1hr

- 1 3/8" concrete
- 28 ga (0.015" thick) steel deck with 5/8" deep corrugations
- 8" x 18 MSG steel joist spaced at 16" o.c. or 24" o.c.
- Optional resilient metal channels spaced at 24" o.c.
- Optional 3 1/2" mineral wool or glass fiber batt insulation
- 2 layers of 1/2" gypsum board on ceiling side

Sound Transmission Class	Impact Insulation Class
24" Joist Spacing	
65* (GFB RC)	29* (GFB RC)
60* (NI RC)	30* (NI RC)
16" Joist Spacing	
66* (GFB RC)	34 ^b (GFB RC)
60* (NI RC)	<30* (NI RC)

* Estimated value per Warnock (2008)

^a TLF-02-051a

^b IIF-02-032

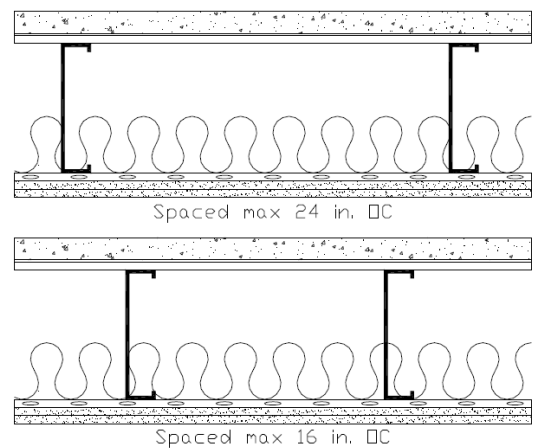

UL G557 Fire Resistance Rating: 2hr

- Subfloor of 3/4" thick tongue-and-groove cement-fiber board designated "Fortacrete"
- 10" x 16 MSG, 6" x 18 MSG or 8" x 16 MSG steel joist spaced at 24" o.c.
- 3 5/8" glass fiber batt insulation
- Resilient metal channels spaced at 12" o.c.
- 2 layers of 5/8" gypsum board on ceiling side.

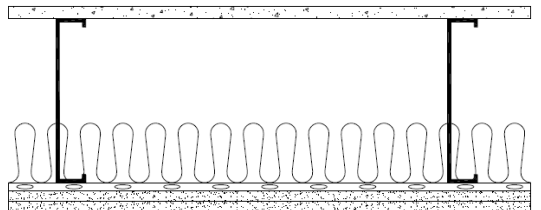

UL G565 Fire Resistance Rating: 1 hr, 1 1/2 hr, 2 hr

- 1" min. floor topping mixture with 3,500 psi comp. strength
- 5/16" min. deep, 22 MSG corrugated fluted steel deck
- 9 1/4" x 16 MSG steel joist spaced at 24" o.c.
- 3 1/2" mineral wool or glass fiber insulation
- 1 and 1/2 hour – 1 layer of 5/8" gypsum board on ceiling side
- 2 hour – 2 layers of 5/8" gypsum board on ceiling side

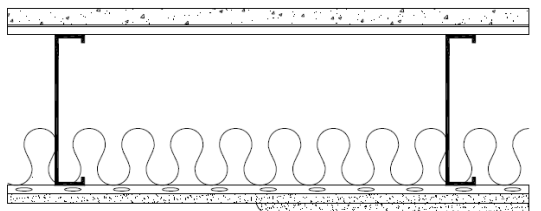

UL L568 Fire Resistance Rating: 45 min

- Subfloor of 5/8" plywood and finish floor of 5/8" wood structural panels
- 8" x 18 MSG steel joists spaced at 16" o.c.
- Resilient metal channels spaced 16" o.c.
- 3 1/2" mineral wool batt insulation
- 1 layer of 5/8" gypsum board on ceiling side

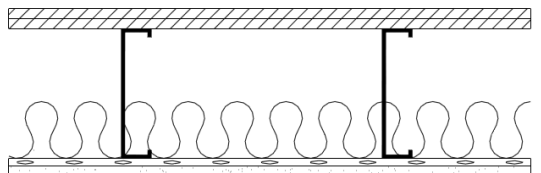

Sound Transmission Class	Impact Insulation Class
53*	46*

* Estimated value per Warnock (2008)

Floor Systems

Introduction

PrimeJoist® is a structural element within the floor assembly where the assembly consists of the PrimeJoist section, metal deck or sheathing attached to the top compression flange, and discrete or continuous bracing attached to the tension flange. As a result, the behavior of the PrimeJoist section is restrained within the floor assembly. The design of PrimeJoist should be in accordance with AISI S100, North American Specification for the Design of Cold-Formed Steel Structural Members, and AISI S240-15, North American Standard for Cold-Formed Steel Structural Framing. Based on the provisions of these two code-referenced documents, the PrimeJoist section would then be checked for the following potential strength and serviceability limit states:

- Initiation of yielding for major axis bending
- Distortional buckling
- Shear
- Web crippling
- Combinations of bending and shear and bending and web crippling
- Vertical deflection at mid-span
- Vertical vibration

Floor Joist Bracing:

Section B1.2.1 in AISI S240-20 Standard permits joist design on the basis of either discretely braced design or continuously braced design. Assumptions for the two methods of design are as follows:

- In discretely braced design, the joist shall be designed neglecting the structural bracing and/or composite action contribution of attached sheathing or deck. Discretely braced design includes assemblies where the sheathing or deck is not attached directly to the joist.
- In continuously braced design, AISI S240-20 Standard limits joist maximum depth to 14 inches, joist maximum thickness to 118 mil (12 ga) and joist maximum design yield strength to 50 ksi. It also requires that the engineering drawings shall identify the sheathing or deck as a structural element. Section B4.5 of AISI S240-20 states that the sheathing shall consist of a minimum of 3/8 inch wood structural sheathing that complies with DOC PS 1, DOC PS 2, CSA 0437 or CSA 0325, or steel deck with a minimum profile depth of 9/16 inch and a minimum thickness of 27 mil. The sheathing or deck shall be attached with minimum No. 8 screws at a maximum 12 inches on center. In addition, it is required that for joist spans that exceed 8 feet, the tension flange shall be laterally braced at a maximum spacing of 8 feet.

Web Crippling:

Web crippling strength is the resistance of a cold-formed steel section with a large web slenderness ratio to resist crippling due to high local intensity of the load or reaction. Sections B1.6 and B2.2.3 in the AISI S240-20 Standard state that web crippling of floor joists shall be evaluated by using Sections G5 and G6, as applicable, of the AISI S100-16 Specification, unless a bearing stiffener is used. The design of bearing stiffeners, other than clip angle bearing stiffeners, shall be in accordance with Section G5 and G6, as applicable, of the AISI S100-16 Specification. Clip angle bearing stiffeners shall be designed in accordance with Section B2.5.1 of the AISI S240-20 standard.

Vertical Deflection and Vibration:

The limitations on maximum vertical deflection and maximum vibration of cold-formed steel floor joists are typically specified in a project with the serviceability limits of the floor system. Vertical deflection limits are available in buildings codes as part of the general design requirements. A limit of L/360 for live load and L/240 for total dead and live load are typically used. However since building codes don't provide limits for floor vibration, it is recommended to use a limit of L/480 for live load to gain additional floor rigidity against any possible floor vibration.

Web Cutouts:

Web cutouts of cold-formed steel floor joists are sometimes required to run duct work or pipes through the floor system. A methodology for a reinforcement solution for the cutout can be engineered by the design professional of the project to restore the design bending capacity of the joist. One reinforcement methodology is to use cold-formed steel channel sections as web reinforcement above and below the cutout. Another methodology is to use a cold-formed steel track section back-to-back with the joist as web reinforcement. In either case, the web reinforcement piece(s) should be attached to the joist by either self-drilling screws or by weld. Some general recommendations about web cutouts are:

- Limit cutout size to a maximum of ½ the depth of the joist.
- Locate the cutout in the center 40% of the joist span, away from high shear zones. Cutouts closer to supports are not recommended, but could be designed if size is limited.

Design Considerations



PrimeJoist® Section Dimensions							
Section (All Studs 50ksi)	Overall Depth	Flange Width	Return Lip 1	Return Lip 2	Inside Bend Radius	Design Thickness	Unit Weight (lbs/ft)
	D	B	d1	d2	R	t	(lbs/ft)
	(in)	(in)	(in)	(in)	(in)	(in)	
600PJ250-43	6	2.5	0.610	0.5	0.105	0.0451	1.94
600PJ250-54	6	2.5	0.633	0.5	0.105	0.0566	2.42
600PJ250-68	6	2.5	0.663	0.5	0.105	0.0713	3.04
600PJ250-97	6	2.5	0.723	0.5	0.105	0.1017	4.30
600PJ250-118	6	2.5	0.768	0.5	0.105	0.1242	5.22
600PJ300-54	6	3	0.6332	0.5	0.105	0.0566	2.616
600PJ300-68	6	3	0.6626	0.5	0.105	0.0713	3.284
600PJ300-97	6	3	0.7234	0.5	0.105	0.1017	4.649
600PJ300-97	6	3	0.7684	0.5	0.105	0.1242	5.646
600PJ350-68	6	3.5	0.6626	0.5	0.105	0.0713	3.527
600PJ350-97	6	3.5	0.7234	0.5	0.105	0.1017	4.995
600PJ350-118	6	3.5	0.7684	0.5	0.105	0.1242	6.069
800PJ250-43	8	2.5	0.6102	0.5	0.105	0.0451	2.244
800PJ250-54	8	2.5	0.6332	0.5	0.105	0.0566	2.809
800PJ250-68	8	2.5	0.6626	0.5	0.105	0.0713	3.527
800PJ250-97	8	2.5	0.7234	0.5	0.105	0.1017	4.995
800PJ250-118	8	2.5	0.7684	0.5	0.105	0.1242	6.069
800PJ300-54	8	3	0.6332	0.5	0.105	0.0566	3.001
800PJ300-68	8	3	0.6626	0.5	0.105	0.0713	3.769
800PJ300-97	8	3	0.7234	0.5	0.105	0.1017	5.342
800PJ300-118	8	3	0.7684	0.5	0.105	0.1242	6.492
800PJ350-68	8	3.5	0.6626	0.5	0.105	0.0713	4.012
800PJ350-97	8	3.5	0.7234	0.5	0.105	0.1017	5.688
800PJ350-118	8	3.5	0.7684	0.5	0.105	0.1242	6.914
1000PJ250-43	10	2.5	0.6102	0.5	0.105	0.0451	2.551
1000PJ250-54	10	2.5	0.6332	0.5	0.105	0.0566	3.194
1000PJ250-68	10	2.5	0.6626	0.5	0.105	0.0713	4.012
1000PJ250-97	10	2.5	0.7234	0.5	0.105	0.1017	5.688
1000PJ250-118	10	2.5	0.7684	0.5	0.105	0.1242	6.914
1000PJ300-54	10	3	0.6332	0.5	0.105	0.0566	3.387
1000PJ300-68	10	3	0.6626	0.5	0.105	0.0713	4.254
1000PJ300-97	10	3	0.7234	0.5	0.105	0.1017	6.034
1000PJ300-118	10	3	0.7684	0.5	0.105	0.1242	7.337
1000PJ350-68	10	3.5	0.6626	0.5	0.105	0.0713	4.497
1000PJ350-97	10	3.5	0.7234	0.5	0.105	0.1017	6.380
1000PJ350-118	10	3.5	0.7684	0.5	0.105	0.1242	7.760
1200PJ250-54	12	2.5	0.6332	0.5	0.105	0.0566	3.579
1200PJ250-68	12	2.5	0.6626	0.5	0.105	0.0713	4.497
1200PJ250-97	12	2.5	0.7234	0.5	0.105	0.1017	6.380
1200PJ250-118	12	2.5	0.7684	0.5	0.105	0.1242	7.760
1200PJ300-54	12	3	0.6332	0.5	0.105	0.0566	3.772
1200PJ300-68	12	3	0.6626	0.5	0.105	0.0713	4.740
1200PJ300-97	12	3	0.7234	0.5	0.105	0.1017	6.726
1200PJ300-118	12	3	0.7684	0.5	0.105	0.1242	8.182
1200PJ350-68	12	3.5	0.6626	0.5	0.105	0.0713	4.982
1200PJ350-97	12	3.5	0.7234	0.5	0.105	0.1017	7.072
1200PJ350-118	12	3.5	0.7684	0.5	0.105	0.1242	8.605
1400PJ250-54	14	2.5	0.6332	0.5	0.105	0.0566	3.964
1400PJ250-68	14	2.5	0.6626	0.5	0.105	0.0713	4.982
1400PJ250-97	14	2.5	0.7234	0.5	0.105	0.1017	7.072
1400PJ250-118	14	2.5	0.7684	0.5	0.105	0.1242	8.605
1400PJ300-54	14	3	0.6332	0.5	0.105	0.0566	4.157
1400PJ300-68	14	3	0.6626	0.5	0.105	0.0713	5.225
1400PJ300-97	14	3	0.7234	0.5	0.105	0.1017	7.418
1400PJ300-118	14	3	0.7684	0.5	0.105	0.1242	9.028
1400PJ350-68	14	3.5	0.6626	0.5	0.105	0.0713	5.468
1400PJ350-97	14	3.5	0.7234	0.5	0.105	0.1017	7.764
1400PJ350-118	14	3.5	0.7684	0.5	0.105	0.1242	9.450

PrimeJoist® Section Dimensions (continued)							
Section (All Studs 50ksi)	Overall Depth	Flange Width	Return Lip 1	Return Lip 2	Inside Bend Radius	Design Thickness	Unit Weight (lbs/ft)
	D (in)	B (in)	d1 (in)	d2 (in)	R (in)	t (in)	(lbs/ft)
1600PJ250-68	16	2.5	0.6626	0.5	0.105	0.0713	5.468
1600PJ250-97	16	2.5	0.7234	0.5	0.105	0.1017	7.764
1600PJ250-118	16	2.5	0.7684	0.5	0.105	0.1242	9.450
1600PJ300-68	16	3	0.6626	0.5	0.105	0.0713	5.710
1600PJ300-97	16	3	0.7234	0.5	0.105	0.1017	8.110
1600PJ300-118	16	3	0.7684	0.5	0.105	0.1242	9.873

Material Properties

ASTM A1003/A1003M Structural Grade 50 (340) Type H, ST50H (ST340H): 50ksi (340MPa) minimum yield strength, 65ksi (450MPa) minimum tensile strength with ASTM A653/A653M G60 (Z180) hot dipped galvanized coating.

Important Notes

1. Calculated properties are based on AISI S100-16, "North American Specification for the Design of Cold-Formed Steel Structural Members."
2. Effective properties incorporate the strength increase from the cold-work of forming as applicable per AISI S100-16 Spec, Sec. A3.3.2 (3).
3. Tabulated gross properties are based on the full-unreduced cross section of the studs, away from punchouts.
4. Allowable moment is the lesser of M_{al} and M_{ad} . Stud distortional buckling is based on an assumed $k_{\phi} = 0$.
5. For deflection calculations, use the effective moment of inertia.
6. The effective moment of inertia for deflection is calculated at a stress which results in a section modulus such that the stress times the section modulus at that stress is equal to the allowable moment. AISI S100-16 Specification Procedure I for serviceability determination has been used. Increases in the effective moment of Inertia (I_{xe}) may be possible at lower stress levels. Any modified values would be required to be calculated by a qualified engineer.

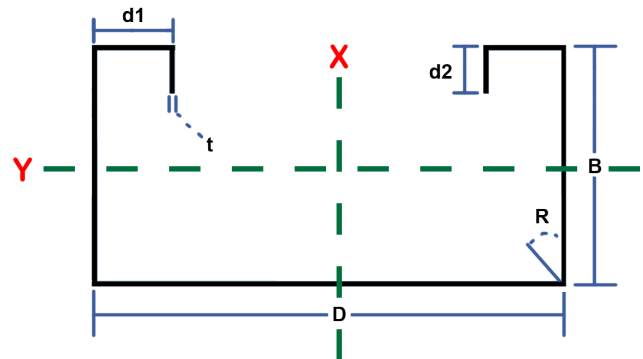

Important Notes

1. Calculated properties are based on AISI S100-16 Spec, "North American Specification for the Design of Cold-Formed Steel Structural Members."
2. Effective properties incorporate the strength increase from the cold-work of forming as applicable per AISI S100-16 Spec, Sec. A3.3.2 (3).
3. Tabulated gross properties are based on the full-unreduced cross section of the studs, away from punchouts.
4. Allowable moment at the net section is the lesser of $M_{al(net)}$ and $M_{ad(net)}$. Stud distortional buckling is based on an assumed $k_{\phi} = 0$.
5. For deflection calculations, use the effective moment of inertia.
6. The effective moment of inertia for deflection is calculated at a stress which results in a section modulus such that the stress times the section modulus at that stress is equal to the allowable moment. AISI S100-16 Specification Procedure I for serviceability determination has been used. Increases in the effective moment of Inertia (I_{xe}) may be possible at lower stress levels. Any modified values would be required to be calculated by a qualified engineer.

PrimeJoist® Section Dimensions																					
Section (All 50 ksi)	Gross Properties							Effective Properties 50 ksi						Torsional Properties						L_u (in.)	
	Area	Weight	I_x	S_x	R_x	I_y	R_y	I_{xe}	S_{xe}	$M_{al(net)}$	$M_{ad(net)}$	V_a	$V_{a(net)}$	$Jx10^3$	C_w	X_o	m	R_o	β		
	(in. ²)	(lb/ft)	(in. ⁴)	(in. ³)	(in.)	(in. ⁴)	(in.)	(in. ⁴)	(in. ²)	(in-k)	(in-k)	(lb)	(lb)	(in. ⁴)	(in. ⁶)	(in.)	(in.)	(in.)			
600PJ250-43	0.569	1.937	3.261	1.087	2.394	0.519	0.955	3.245	0.919	27.502	23.076	1,432	1,235	0.386	4.150	-2.088	1.266	3.317	0.604	53.32	
600PJ250-54	0.712	2.424	4.058	1.353	2.387	0.644	0.951	4.058	1.174	35.140	31.545	2,842	1,942	0.760	5.163	-2.082	1.263	3.307	0.604	53.38	
600PJ250-68	0.894	3.041	5.055	1.685	2.378	0.801	0.947	5.055	1.526	45.679	43.085	5,352	2,882	1.514	6.431	-2.074	1.259	3.295	0.604	53.47	
600PJ250-97	1.265	4.303	7.047	2.349	2.361	1.111	0.937	7.047	2.305	77.070	73.996	10,653	3,964	4.360	8.956	-2.058	1.250	3.269	0.604	53.76	
600PJ250-118	1.535	5.224	8.459	2.820	2.348	1.328	0.930	8.459	2.820	96.045	95.554	12,905	3,888	7.893	10.737	-2.045	1.244	3.249	0.604	54.05	
600PJ300-54	0.769	2.616	4.558	1.519	2.435	0.997	1.139	4.414	1.212	36.282	32.808	2,842	1,942	0.821	7.935	-2.545	1.519	3.702	0.527	62.53	
600PJ300-68	0.965	3.284	5.682	1.894	2.427	1.241	1.134	5.633	1.587	47.517	45.077	5,352	2,882	1.635	9.901	-2.538	1.515	3.690	0.527	62.67	
600PJ300-97	1.366	4.649	7.931	2.644	2.409	1.729	1.125	7.931	2.495	74.697	72.450	10,653	3,964	4.710	13.841	-2.521	1.507	3.665	0.527	63.07	
600PJ300-118	1.659	5.646	9.531	3.177	2.397	2.074	1.118	9.531	3.046	101.688	101.217	12,905	3,888	8.531	16.640	-2.509	1.501	3.646	0.526	63.46	
600PJ350-68	1.036	3.527	6.309	2.103	2.467	1.799	1.318	6.055	1.628	48.757	46.671	5,352	2,882	1.756	14.285	-3.006	1.771	4.106	0.464	71.51	
600PJ350-97	1.468	4.995	8.816	2.939	2.451	2.513	1.308	8.730	2.534	75.856	75.750	10,653	3,964	5.061	20.020	-2.990	1.763	4.081	0.463	72.01	
600PJ350-118	1.783	6.069	10.603	3.534	2.438	3.021	1.301	10.603	3.336	99.875	98.557	12,905	3,888	9.170	24.116	-2.978	1.757	4.063	0.463	72.48	
800PJ250-43	0.659	2.244	6.378	1.595	3.110	0.572	0.931	6.378	1.225	36.664	31.517	1,060	1,060	0.447	7.513	-1.869	1.159	3.746	0.751	52.27	
800PJ250-54	0.825	2.809	7.949	1.987	3.103	0.710	0.927	7.949	1.700	50.893	43.391	2,102	2,102	0.881	9.340	-1.862	1.156	3.736	0.752	52.24	
800PJ250-68	1.036	3.527	9.923	2.481	3.095	0.883	0.923	9.923	2.260	67.676	59.780	4,218	3,367	1.756	11.624	-1.854	1.151	3.724	0.752	52.23	
800PJ250-97	1.468	4.995	13.893	3.473	3.076	1.225	0.914	13.893	3.409	113.945	104.140	10,888	6,034	5.061	16.161	-1.838	1.142	3.698	0.753	52.24	
800PJ250-118	1.783	6.069	16.731	4.183	3.063	1.466	0.907	16.731	4.183	142.471	137.142	16,239	7,314	9.170	19.351	-1.825	1.135	3.679	0.754	52.29	
800PJ300-54	0.882	3.001	8.841	2.210	3.166	1.101	1.117	8.679	1.710	51.186	44.865	2,102	2,102	0.942	14.345	-2.298	1.404	4.069	0.681	61.53	
800PJ300-68	1.108	3.769	11.044	2.761	3.158	1.371	1.113	11.018	2.346	70.242	62.091	4,218	3,367	1.877	17.884	-2.290	1.399	4.056	0.681	61.54	
800PJ300-97	1.570	5.342	15.479	3.870	3.140	1.911	1.103	15.479	3.658	109.530	101.212	10,888	6,034	5.411	24.958	-2.274	1.391	4.031	0.682	61.64	
800PJ300-118	1.908	6.492	18.657	4.664	3.127	2.293	1.096	18.657	4.475	149.413	142.478	16,239	7,314	9.808	29.972	-2.261	1.384	4.012	0.682	61.76	
800PJ350-68	1.179	4.012	12.165	3.041	3.212	1.990	1.299	11.805	2.406	72.028	63.855	4,218	3,367	1.998	25.787	-2.733	1.648	4.413	0.616	70.53	
800PJ350-97	1.671	5.688	17.065	4.266	3.195	2.782	1.290	16.974	3.711	111.105	104.925	10,888	6,034	5.762	36.082	-2.717	1.640	4.388	0.617	70.69	
800PJ350-118	2.032	6.914	20.583	5.146	3.183	3.346	1.283	20.583	4.863	145.598	137.703	16,239	7,314	10.447	43.418	-2.705	1.633	4.370	0.617	70.87	
1000PJ250-43 ¹	0.750	2.551	10.814	2.163	3.798	0.611	0.903	10.814	1.532	45.859	39.691	842	842	0.508	12.166	-1.696	1.072	4.257	0.841	51.47	
1000PJ250-54	0.939	3.194	13.490	2.698	3.791	0.760	0.900	13.490	2.106	63.057	54.992	1,667	1,667	1.002	15.121	-1.690	1.068	4.247	0.842	51.40	
1000PJ250-68	1.179	4.012	16.864	3.373	3.782	0.945	0.895	16.864	3.055	91.457	76.339	3,343	3,343	1.998	18.812	-1.682	1.064	4.235	0.842	51.32	
1000PJ250-97	1.671	5.688	23.674	4.735	3.764	1.312	0.886	23.674	4.649	155.425	134.635	9,764	7,189	5.762	26.138	-1.666	1.055	4.210	0.843	51.19	
1000PJ250-118	2.032	6.914	28.570	5.714	3.750	1.569	0.879	28.570	5.714	194.624	178.952	16,239	9,736	10.447	31.285	-1.653	1.048	4.191	0.844	51.12	
1000PJ300-54	0.995	3.387	14.889	2.978	3.868	1.181	1.089	14.748	2.128	63.707	56.875	1,667	1,667	1.063	23.216	-2.100	1.308	4.534	0.785	60.80	
1000PJ300-68	1.250	4.254	18.621	3.724	3.859	1.471	1.085	18.621	3.089	92.482	79.197	3,343	3,343	2.118	28.935	-2.092	1.304	4.522	0.786	60.75	
1000PJ300-97	1.773	6.034	26.165	5.233	3.842	2.051	1.076	26.165	4.961	148.521	130.623	9,764	7,189	6.113	40.358	-2.076	1.295	4.497	0.787	60.69	
1000PJ300-118	2.156	7.337	31.598	6.320	3.828	2.462	1.069	31.598	6.074	202.789	185.028	16,239	9,736	11.086	48.447	-2.063	1.288	4.478	0.788	60.67	
1000PJ350-68	1.321	4.497	20.378	4.076	3.927	2.140	1.273	19.945	3.095	92.661	81.262	3,343	3,343	2.239	41.705	-2.513	1.545	4.833	0.730	69.88	
1000PJ350-97	1.875	6.380	28.656	5.731	3.910	2.993	1.263	28.651	5.030	150.590	134.865	9,764	7,189	6.463	58.323	-2.497	1.536	4.808	0.730	69.87	
1000PJ350-118	2.280	7.760	34.627	6.925	3.897	3.600	1.257	34.627	6.560	196.413	178.222	16,239	9,736	11.724	70.156	-2.484	1.529	4.789	0.731	69.89	
1200PJ250-54 ¹	1.052	1.052	20.909	3.485	4.459	0.799	0.871	19.943	2.417	72.373	65.871	1,382	1,382	1.123	22.624	-1.550	0.995	4.800	0.896	50.62	
1200PJ250-68	1.321	4.497	26.162	4.360	4.449	0.993	0.867	25.428	3.342	100.048	92.102	2,769	2,769	2.239	28.143	-1.542	0.991	4.788	0.896	50.51	
1200PJ250-97	1.875	6.380	36.799	6.133	4.430	1.379	0.858	36.695	5.692	170.411	152.901	8,078	7,419	6.463	39.093	-1.526	0.981	4.764	0.897	50.29	

PrimeJoist® Section Dimensions (continued)																				
Section (All 50 ksi)	Gross Properties							Effective Properties 50 ksi						Torsional Properties						L _u (in.)
	Area	Weight	I _x	S _x	R _x	I _y	R _y	I _{xo}	S _{xo}	M _{a(net)}	M _{sd(net)}	V _a	V _{a(net)}	Jx10 ⁶	C _w	X _o	m	R _o	β	
	(in. ²)	(lb/ft)	(in. ⁴)	(in. ³)	(in.)	(in. ⁴)	(in.)	(in. ⁴)	(in. ³)	(in-k)	(in-k)	(lb)	(lb)	(in. ⁴)	(in. ⁶)	(in.)	(in.)	(in.)		
1200PJ300-54 ¹	1.108	3.772	22.927	3.821	4.548	1.245	1.060	22.868	2.548	76.292	68.452	1,382	1,382	1.184	34.744	-1.938	1.226	5.056	0.853	60.13
1200PJ300-68	1.393	4.740	28.699	4.783	4.539	1.551	1.055	28.699	3.667	109.801	95.865	2,769	2,769	2.360	43.298	-1.930	1.222	5.044	0.854	60.04
1200PJ300-97	1.976	6.726	40.398	6.733	4.521	2.163	1.046	40.398	6.401	191.634	159.837	8,078	7,419	6.814	60.378	-1.914	1.213	5.020	0.855	59.87
1200PJ300-118	2.404	8.182	48.851	8.142	4.508	2.596	1.039	48.851	7.840	261.770	227.693	14,771	11,058	12.363	72.473	-1.901	1.206	5.001	0.855	59.77
1200PJ350-68	1.464	4.982	31.235	5.206	4.619	2.261	1.243	30.690	3.689	110.448	98.487	2,769	2,769	2.481	62.405	-2.330	1.456	5.320	0.808	69.28
1200PJ350-97	2.078	7.072	43.997	7.333	4.601	3.162	1.233	43.997	6.488	194.254	164.928	8,078	7,419	7.165	87.257	-2.314	1.447	5.296	0.809	69.16
1200PJ350-118	2.529	8.605	53.231	8.872	4.588	3.804	1.227	53.231	8.426	252.273	219.291	14,771	11,058	13.002	104.953	-2.301	1.440	5.277	0.810	69.10
1400PJ250-54 ¹	1.165	3.964	30.431	4.347	5.111	0.830	0.844	28.428	2.847	85.237	75.698	1,180	1,180	1.244	31.939	-1.433	0.932	5.375	0.929	49.87
1400PJ250-68	1.464	4.982	38.103	5.443	5.102	1.032	0.840	36.379	3.948	118.208	106.579	2,363	2,363	2.481	39.728	-1.425	0.928	5.363	0.929	49.73
1400PJ250-97	2.078	7.072	53.672	7.667	5.082	1.434	0.831	52.843	6.793	203.381	179.251	6,889	6,889	7.165	55.181	-1.410	0.918	5.339	0.930	49.46
1400PJ250-118	2.529	8.605	64.935	9.276	5.068	1.716	0.824	64.886	8.634	258.514	238.603	12,590	11,302	13.002	66.037	-1.398	0.911	5.321	0.931	49.26
1400PJ300-54 ¹	1.222	4.157	33.182	4.740	5.212	1.297	1.030	31.280	2.898	86.763	79.256	1,180	1,180	1.304	49.081	-1.801	1.155	5.610	0.897	59.44
1400PJ300-68	1.535	5.225	41.562	5.937	5.203	1.616	1.026	39.947	4.052	121.330	111.616	2,363	2,363	2.602	61.164	-1.793	1.151	5.598	0.897	59.32
1400PJ300-97	2.180	7.418	58.583	8.369	5.184	2.253	1.017	57.867	7.033	210.580	188.044	6,889	6,889	7.515	85.287	-1.777	1.141	5.574	0.898	59.09
1400PJ300-118	2.653	9.028	70.913	10.130	5.170	2.705	1.010	70.913	9.216	275.920	250.851	12,590	11,302	13.640	102.371	-1.765	1.134	5.556	0.899	58.94
1400PJ350-68	1.607	5.468	45.020	6.431	5.293	2.360	1.212	44.433	4.287	128.339	115.113	2,363	2,363	2.723	88.183	-2.174	1.378	5.850	0.862	68.66
1400PJ350-97	2.282	7.764	63.494	9.071	5.275	3.301	1.203	63.494	7.930	237.411	194.426	6,889	6,889	7.866	123.298	-2.158	1.369	5.825	0.863	68.47
1400PJ350-118	2.777	9.450	76.891	10.984	5.262	3.972	1.196	76.891	10.459	313.149	260.010	12,590	11,302	14.279	148.305	-2.146	1.362	5.807	0.863	68.34
1600PJ250-68 ¹	1.607	5.468	52.973	6.622	5.742	1.065	0.814	49.675	4.553	136.326	119.534	2,061	2,061	2.723	53.658	-1.326	0.873	5.949	0.950	48.97
1600PJ250-97	2.282	7.764	74.702	9.338	5.722	1.478	0.805	72.546	7.893	236.316	203.525	6,005	6,005	7.866	74.527	-1.311	0.864	5.925	0.951	48.66
1600PJ250-118	2.777	9.450	90.455	11.307	5.707	1.769	0.798	89.400	10.093	302.172	273.159	10,970	10,970	14.279	89.188	-1.300	0.857	5.908	0.952	48.43
1600PJ300-68 ¹	1.678	5.710	57.495	7.187	5.854	1.670	0.998	54.339	4.670	139.824	126.118	2,061	2,061	2.843	82.684	-1.676	1.088	6.170	0.926	58.60
1600PJ300-97	2.383	8.110	81.128	10.141	5.835	2.328	0.988	79.123	8.154	244.141	214.626	6,005	6,005	8.216	115.296	-1.660	1.079	6.146	0.927	58.33
1600PJ300-118	2.901	9.873	98.280	12.285	5.820	2.796	0.982	97.372	10.745	321.703	288.248	10,970	10,970	14.917	138.394	-1.648	1.072	6.128	0.928	58.13
1600PJ350-68 ¹	1.749	5.953	62.018	7.752	5.954	2.443	1.182	58.472	4.736	141.796	130.789	2,061	2,061	2.964	119.278	-2.040	1.308	6.404	0.899	68.01
1600PJ350-97	2.485	8.456	87.555	10.944	5.936	3.417	1.173	85.734	8.165	244.465	222.751	6,005	6,005	8.567	166.780	-2.024	1.299	6.380	0.899	67.77
1600PJ350-118	3.025	10.296	106.106	13.263	5.922	4.112	1.166	105.380	11.331	339.256	299.554	10,970	10,970	15.556	200.614	-2.012	1.292	6.362	0.900	67.60

¹Web-height-to-thickness ratio exceeds 200. Web stiffeners are required at all support points and concentric loads. Suitability of web holes must be evaluated independently.

Floor Systems

Allowable Floor Joist Span Tables

Important Notes

1. Calculated allowable properties are based on AISI S100-16/S2-20, "North American Specification for the Design of Cold-Formed Steel Structural Members."
2. Spans are based on continuous support of compression flange over the full length of the joist.
3. End shear and web crippling capacities have not been reduced for punchouts.
4. For two equal spans, the listed span is the center-to-center distance from either end to the center support, with the joist continuous over the center support.
5. Joists must be braced against rotation at all supports.
6. End and interior web crippling checks are based on 3.5 inch bearing length. Joist flanges must be fastened to the support.
7. Shear capacity at mid-span support has been reduced for the presence of punchouts adjacent to the support. Mid-span combined bending and shear check based on stiffened web.
8. Deflection checks are computed using unbalanced loads for the two equal span condition.
9. Total load deflection limited to L/240. Live load deflection limit as noted.
10. " e " indicates that web stiffeners are required at the end supports only.
11. " i " indicates that web stiffeners are required at the interior supports only.
12. " a " indicates that web stiffeners are required at all the supports.
13. Allowable flexural strength values in the tables are based on the minimum of local, distortional, and lateral-torsional buckling. Distortional buckling strength is based on a $k_{\phi} = 0$. Higher values may be obtained when sheathing is applied to the walls resulting in a higher k_{ϕ} value.

10 psf Dead Load and 20 psf Live Load												
Section (All 50 ksi)	Live Load Deflection L/360						Live Load Deflection L/480					
	Single Span			Two Equal Spans			Single Span			Two Equal Spans		
	Spacing (in.) o.c.			Spacing (in.) o.c.			Spacing (in.) o.c.			Spacing (in.) o.c.		
	12	16	24	12	16	24	12	16	24	12	16	24
600PJ250-43	19' 0"	17' 3"	15' 1"	21' 4" i	19' 5" i	16' 7" i	17' 3"	15' 8"	13' 8"	19' 5"	17' 7" i	15' 5" i
600PJ250-54	20' 6"	18' 8"	16' 3"	23' 1"	21' 0" i	18' 4" i	18' 8"	16' 11"	14' 10"	21' 0"	19' 1"	16' 8" i
600PJ250-68	22' 3"	20' 2"	17' 8"	25' 0"	22' 9"	19' 10"	20' 2"	18' 4"	16' 0"	22' 9"	20' 8"	18' 0"
600PJ250-97	24' 10"	22' 7"	19' 8"	27' 11"	25' 5"	22' 2"	22' 7"	20' 6"	17' 11"	25' 5"	23' 1"	20' 2"
600PJ250-118	26' 5"	24' 0"	20' 11"	29' 8"	27' 0"	23' 7"	24' 0"	21' 9"	19' 0"	27' 0"	24' 6"	21' 5"
600PJ300-54	21' 0"	19' 1"	16' 8"	23' 7"	21' 5" i	18' 9" i	19' 1"	17' 4"	15' 1"	21' 5"	19' 6"	17' 0" i
600PJ300-68	22' 10"	20' 9"	18' 2"	25' 9"	23' 4"	20' 5" i	20' 9"	18' 10"	16' 6"	23' 4"	21' 3"	18' 6"
600PJ300-97	25' 10"	23' 6"	20' 6"	29' 1"	26' 5"	23' 1"	23' 6"	21' 4"	18' 7"	26' 5"	24' 0"	20' 11"
600PJ300-118	27' 6"	24' 11"	21' 10"	30' 11"	28' 1"	24' 6"	24' 11"	22' 8"	19' 10"	28' 1"	25' 6"	22' 3"
600PJ350-68	23' 3"	21' 2"	18' 5"	26' 2"	23' 9"	20' 9" i	21' 2"	19' 2"	16' 9"	23' 9"	21' 7"	18' 10"
600PJ350-97	26' 7"	24' 2"	21' 1"	29' 11"	27' 2"	23' 9"	24' 2"	21' 11"	19' 2"	27' 2"	24' 8"	21' 7"
600PJ350-118	28' 6"	25' 10"	22' 7"	32' 0"	29' 1"	25' 5"	25' 10"	23' 6"	20' 6"	29' 1"	26' 5"	23' 1"
800PJ250-43	23' 9"	21' 7"	18' 8" e	26' 9" i	22' 8" i	17' 9" i	21' 7"	19' 7"	17' 2"	24' 3" i	22' 1" i	17' 9" i
800PJ250-54	25' 8"	23' 4"	20' 5"	28' 11" i	26' 3" i	22' 8" i	23' 4"	21' 3"	18' 6"	26' 3"	23' 10" i	20' 10" i
800PJ250-68	27' 10"	25' 4"	22' 1"	31' 4"	28' 5"	24' 10" i	25' 4"	23' 0"	20' 1"	28' 5"	25' 10"	22' 7"
800PJ250-97	31' 2"	28' 4"	24' 9"	35' 1"	31' 10"	27' 10"	28' 4"	25' 9"	22' 5"	31' 10"	28' 11"	25' 3"
800PJ250-118	33' 2"	30' 1"	26' 4"	37' 3"	33' 10"	29' 7"	30' 1"	27' 4"	23' 11"	33' 10"	30' 9"	26' 11"
800PJ300-54	26' 2"	23' 10"	20' 9"	29' 6" i	26' 9" i	22' 9" i	23' 10"	21' 7"	18' 11"	26' 9"	24' 4" i	21' 3" i
800PJ300-68	28' 7"	25' 11"	22' 8"	32' 1"	29' 2"	25' 6" i	25' 11"	23' 7"	20' 7"	29' 2"	26' 6"	23' 2" i
800PJ300-97	32' 4"	29' 4"	25' 8"	36' 4"	33' 0"	28' 10"	29' 4"	26' 8"	23' 3"	33' 0"	30' 0"	26' 2"
800PJ300-118	34' 5"	31' 3"	27' 3"	38' 8"	35' 2"	30' 8"	31' 3"	28' 4"	24' 9"	35' 2"	31' 11"	27' 10"
800PJ350-68	29' 0"	26' 4"	23' 0"	32' 7"	29' 8"	25' 11" i	26' 4"	23' 11"	20' 11"	29' 8"	26' 11"	23' 6" i
800PJ350-97	33' 1"	30' 1"	26' 3"	37' 3"	33' 10"	29' 7"	30' 1"	27' 4"	23' 10"	33' 10"	30' 9"	26' 10"
800PJ350-118	35' 6"	32' 3"	28' 2"	39' 11"	36' 4"	31' 8"	32' 3"	29' 4"	25' 7"	36' 4"	33' 0"	28' 10"

Web Stiffener: Stud Segment on Back of Joist

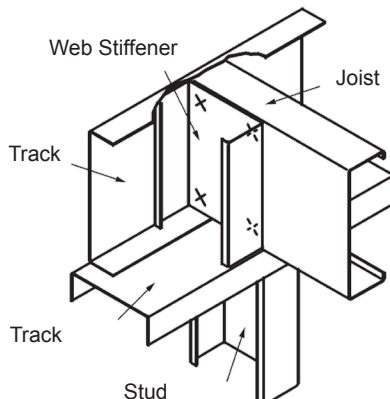

Web Stiffener: Track Inside Joist

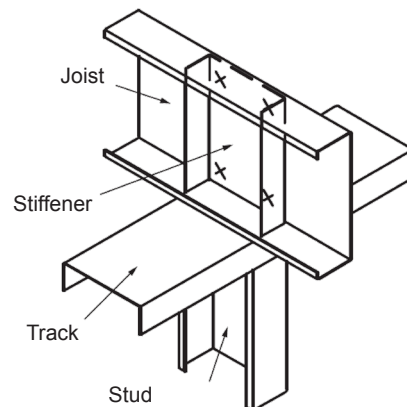

Refer to Important Table Notes on Page 82

10 psf Dead Load and 20 psf Live Load												
Section (All 50 ksi)	Live Load Deflection L/360						Live Load Deflection L/480					
	Single Span			Two Equal Spans			Single Span			Two Equal Spans		
	Spacing (in.) o.c.			Spacing (in.) o.c.			Spacing (in.) o.c.			Spacing (in.) o.c.		
	12	16	24	12	16	24	12	16	24	12	16	24
1000PJ250-43	27' 11"	25' 5"	21' 0" e	28' 2" i	23' 5" i	17' 8" i	25' 5"	23' 1"	20' 2" e	28' 2" i	23' 5" i	17' 8" i
1000PJ250-54	30' 8"	27' 10"	24' 4"	34' 6" i	30' 6" i	24' 2" i	27' 10"	25' 4"	22' 1"	31' 4" i	28' 6" i	24' 2" i
1000PJ250-68	33' 3"	30' 2"	26' 4"	37' 5"	34' 0" i	29' 8" i	30' 2"	27' 5"	23' 11"	34' 0" i	30' 10" i	26' 11" i
1000PJ250-97	37' 3"	33' 10"	29' 6"	41' 10"	38' 0" i	33' 3" i	33' 10"	30' 9"	26' 10"	38' 0" i	34' 7" i	30' 2" i
1000PJ250-118	39' 8"	36' 0"	31' 5"	44' 7"	40' 6" i	35' 4" i	36' 0"	32' 8"	28' 7"	40' 6" i	36' 9" i	32' 2" i
1000PJ300-54	31' 2"	28' 4"	24' 9"	35' 1" i	30' 8" i	24' 4" i	28' 4"	25' 9"	22' 6"	31' 10" i	28' 11" i	24' 4" i
1000PJ300-68	34' 0"	30' 11"	27' 0"	38' 3"	34' 9" i	30' 4" i	30' 11"	28' 1"	24' 6"	34' 9" i	31' 7" i	27' 7" i
1000PJ300-97	38' 6"	35' 0"	30' 6"	43' 3"	39' 4"	34' 4" i	35' 0"	31' 9"	27' 9"	39' 4" i	35' 9" i	31' 2" i
1000PJ300-118	41' 0"	37' 3"	32' 6"	46' 1"	41' 11"	36' 7" i	37' 3"	33' 10"	29' 7"	41' 11" i	38' 1" i	33' 3" i
1000PJ350-68	34' 6"	31' 4"	27' 4"	38' 10"	35' 3" i	30' 9" i	31' 4"	28' 6"	24' 10"	35' 3" i	32' 0" i	28' 0" i
1000PJ350-97	39' 5"	35' 9"	31' 3"	44' 4"	40' 3" i	35' 2" i	35' 9"	32' 6"	28' 5"	40' 3" i	36' 7" i	31' 11" i
1000PJ350-118	42' 3"	38' 5"	33' 6"	47' 6"	43' 2" i	37' 9" i	38' 5"	34' 10"	30' 6"	43' 2" i	39' 3" i	34' 3" i
1200PJ250-54	34' 7"	31' 5"	27' 0" e	37' 3" i	31' 5" i	24' 6" i	31' 5"	28' 6"	24' 11"	35' 4" i	31' 5" i	24' 6" i
1200PJ250-68	37' 11"	34' 5"	30' 1"	42' 7" i	38' 9" i	31' 8" i	34' 5"	31' 3"	27' 4"	38' 9" i	35' 2" i	30' 9" i
1200PJ250-97	43' 0"	39' 0"	34' 1"	48' 4"	43' 11" i	38' 4" i	39' 0"	35' 6"	31' 0"	43' 11" i	39' 11" i	34' 10" i
1200PJ250-118	45' 11"	41' 9"	36' 5"	51' 8"	46' 11" i	41' 0" i	41' 9"	37' 11"	33' 1"	46' 11" i	42' 8" i	37' 3" i
1200PJ300-54	35' 6"	32' 3"	27' 6" e	38' 1" i	32' 1" i	24' 11" i	32' 3"	29' 3"	25' 7"	36' 3" i	32' 1" i	24' 11" i
1200PJ300-68	39' 3"	35' 8"	31' 2"	44' 2" i	40' 2" i	33' 0" i	35' 8"	32' 5"	28' 4"	40' 2" i	36' 6" i	31' 10" i
1200PJ300-97	44' 6"	40' 5"	35' 4"	50' 0"	45' 6" i	39' 8" i	40' 5"	36' 9"	32' 1"	45' 6" i	41' 4" i	36' 1" i
1200PJ300-118	47' 5"	43' 1"	37' 7"	53' 4"	48' 5" i	42' 4" i	43' 1"	39' 1"	34' 2"	48' 5" i	44' 0" i	38' 5" i
1200PJ350-68	39' 10"	36' 2"	31' 7"	44' 10" i	40' 8" i	33' 1" i	36' 2"	32' 10"	28' 8"	40' 8" i	37' 0" i	32' 4" i
1200PJ350-97	45' 5"	41' 3"	36' 1"	51' 1"	46' 5" i	40' 7" i	41' 3"	37' 6"	32' 9"	46' 5" i	42' 2" i	36' 10" i
1200PJ350-118	48' 9"	44' 4"	38' 8"	54' 10" i	49' 10" i	43' 6" i	44' 4"	40' 3"	35' 2"	49' 10" i	45' 3" i	39' 7" i
1400PJ250-54	38' 10"	35' 3"	29' 0" e	38' 7" i	32' 2" i	24' 5" i	35' 3"	32' 0"	28' 0" e	38' 7" i	32' 2" i	24' 5" i
1400PJ250-68	42' 7"	38' 8"	33' 9"	47' 11" i	42' 0" i	33' 4" i	38' 8"	35' 2"	30' 8"	43' 6" i	39' 6" i	33' 4" i
1400PJ250-97	48' 5"	44' 0"	38' 5"	54' 6"	49' 6" i	43' 3" i	44' 0"	40' 0"	34' 11"	49' 6" i	45' 0" i	39' 3" i
1400PJ250-118	52' 0"	47' 3"	41' 3"	58' 6"	53' 1" i	46' 5" i	47' 3"	42' 11"	37' 6"	53' 1" i	48' 3" i	42' 2" i
1400PJ300-54	39' 4"	35' 8"	29' 8" e	38' 11" i	32' 5" i	24' 6" i	35' 8"	32' 5"	28' 4" e	38' 11" i	32' 5" i	24' 6" i
1400PJ300-68	43' 4"	39' 5"	34' 5"	48' 9" i	42' 6" i	33' 8" i	39' 5"	35' 9"	31' 3"	44' 4" i	40' 3" i	33' 8" i
1400PJ300-97	49' 11"	45' 4"	39' 7"	56' 2"	51' 0" i	44' 7" i	45' 4"	41' 2"	36' 0"	51' 0" i	46' 4" i	40' 6" i
1400PJ300-118	53' 7"	48' 8"	42' 6"	60' 3"	54' 9" i	47' 10" i	48' 8"	44' 2"	38' 7"	54' 9" i	49' 9" i	43' 5" i
1400PJ350-68	44' 5"	40' 5"	35' 3"	50' 0" i	43' 6" i	34' 6" i	40' 5"	36' 8"	32' 1"	45' 5" i	41' 3" i	34' 6" i
1400PJ350-97	51' 4"	46' 8"	40' 9"	57' 9"	52' 6" i	45' 10" i	46' 8"	42' 5"	37' 0"	52' 6" i	47' 8" i	41' 8" i
1400PJ350-118	55' 2"	50' 1"	43' 9"	62' 0"	56' 4" i	49' 3" i	50' 1"	45' 6"	39' 9"	56' 4" i	51' 2" i	44' 9" i
1600PJ250-68	47' 1"	42' 9"	36' 5"	51' 8" i	43' 10" i	34' 4" i	42' 9"	38' 10"	33' 11"	48' 1" i	43' 9" i	34' 4" i
1600PJ250-97	53' 8"	48' 10"	42' 7"	60' 5"	54' 11" i	47' 11" i	48' 10"	44' 4"	38' 9"	54' 11" i	49' 10" i	43' 7" i
1600PJ250-118	57' 9"	52' 6"	45' 10"	64' 11"	59' 0" i	51' 7" i	52' 6"	47' 8"	41' 8"	59' 0" i	53' 7" i	46' 10" i
1600PJ300-68	47' 11"	43' 6"	37' 5"	52' 3" i	44' 3" i	34' 8" i	43' 6"	39' 6"	34' 6"	48' 11" i	44' 3" i	34' 8" i
1600PJ300-97	55' 3"	50' 3"	43' 11"	62' 2"	56' 6" i	49' 4" i	50' 3"	45' 8"	39' 10"	56' 6" i	51' 4" i	44' 10" i
1600PJ300-118	59' 5"	54' 0"	47' 2"	66' 10"	60' 9" i	53' 0" i	54' 0"	49' 0"	42' 10"	60' 9" i	55' 2" i	48' 2" i
1600PJ350-68	48' 4"	43' 11"	38' 1"	52' 7" i	44' 7" i	34' 10" i	43' 11"	39' 11"	34' 10"	49' 5" i	44' 7" i	34' 10" i
1600PJ350-97	56' 4"	51' 2"	44' 8"	63' 4"	57' 7" i	50' 3" i	51' 2"	46' 6"	40' 7"	57' 7" i	52' 3" i	45' 8" i
1600PJ350-118	61' 0"	55' 5"	48' 5"	68' 7"	62' 4" i	54' 5" i	55' 5"	50' 4"	44' 0"	62' 4" i	56' 7" i	49' 5" i

Web Stiffener: Clip Angle

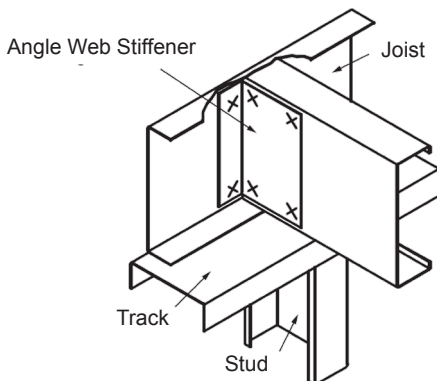

Web Stiffener: Joist Reinforcement

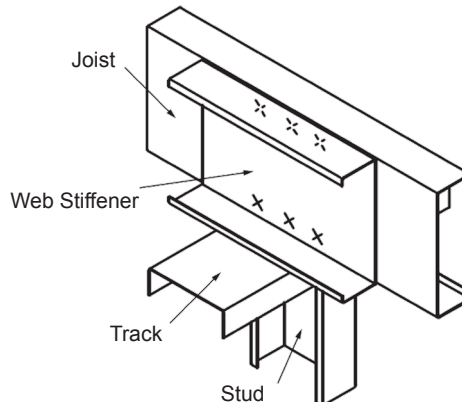

Refer to Important Table Notes on Page 82

10 psf Dead Load and 30 psf Live Load												
Section (All 50 ksi)	Live Load Deflection L/360						Live Load Deflection L/480					
	Single Span			Two Equal Spans			Single Span			Two Equal Spans		
	Spacing (in.) o.c.			Spacing (in.) o.c.			Spacing (in.) o.c.			Spacing (in.) o.c.		
	12	16	24	12	16	24	12	16	24	12	16	24
600PJ250-43	16' 7"	15' 1"	13' 2"	18' 8" i	16' 11" i	14' 1" i	15' 1"	13' 8"	11' 11"	16' 11" i	15' 5" i	13' 5" i
600PJ250-54	17' 11"	16' 3"	14' 3"	20' 2"	18' 4" i	16' 0" i	16' 3"	14' 10"	12' 11"	18' 4"	16' 8"	14' 6" i
600PJ250-68	19' 5"	17' 8"	15' 5"	21' 10"	19' 10"	17' 4" i	17' 8"	16' 0"	14' 0"	19' 10"	18' 0"	15' 9"
600PJ250-97	21' 8"	19' 8"	17' 3"	24' 5"	22' 2"	19' 4"	19' 8"	17' 11"	15' 8"	22' 2"	20' 2"	17' 7"
600PJ250-118	23' 1"	20' 11"	18' 3"	25' 11"	23' 7"	20' 7"	20' 11"	19' 0"	16' 7"	23' 7"	21' 5"	18' 8"
600PJ300-54	18' 4"	16' 8"	14' 6"	20' 7"	18' 9" i	16' 4" i	16' 8"	15' 1"	13' 2"	18' 9"	17' 0"	14' 10" i
600PJ300-68	20' 0"	18' 2"	15' 10"	22' 6"	20' 5"	17' 10" i	18' 2"	16' 6"	14' 5"	20' 5"	18' 6"	16' 2"
600PJ300-97	22' 7"	20' 6"	17' 11"	25' 5"	23' 1"	20' 2"	20' 6"	18' 7"	16' 3"	23' 1"	20' 11"	18' 4"
600PJ300-118	24' 0"	21' 10"	19' 0"	27' 0"	24' 6"	21' 5"	21' 10"	19' 10"	17' 3"	24' 6"	22' 3"	19' 5"
600PJ350-68	20' 4"	18' 5"	16' 1"	22' 10"	20' 9"	18' 2" i	18' 5"	16' 9"	14' 8"	20' 9"	18' 10"	16' 6"
600PJ350-97	23' 3"	21' 1"	18' 5"	26' 1"	23' 9"	20' 9"	21' 1"	19' 2"	16' 9"	23' 9"	21' 7"	18' 10"
600PJ350-118	24' 10"	22' 7"	19' 9"	28' 0"	25' 5"	22' 2"	22' 7"	20' 6"	17' 11"	25' 5"	23' 1"	20' 2"
800PJ250-43	20' 9"	18' 10"	16' 2" e	22' 8" i	19' 1" i	14' 9" i	18' 10"	17' 2"	14' 11" e	21' 3" i	19' 1" i	14' 9" i
800PJ250-54	22' 5"	20' 5"	17' 10"	25' 3" i	22' 11" i	19' 4" i	20' 5"	18' 6"	16' 2"	22' 11"	20' 10" i	18' 2" i
800PJ250-68	24' 4"	22' 1"	19' 4"	27' 4"	24' 10" i	21' 8" i	22' 1"	20' 1"	17' 6"	24' 10"	22' 7"	19' 9" i
800PJ250-97	27' 3"	24' 9"	21' 7"	30' 7"	27' 10"	24' 3"	24' 9"	22' 5"	19' 7"	27' 10"	25' 3"	22' 1"
800PJ250-118	28' 11"	26' 4"	23' 0"	32' 7"	29' 7"	25' 10"	26' 4"	23' 11"	20' 10"	29' 7"	26' 11"	23' 6"
800PJ300-54	22' 11"	20' 9"	18' 2"	25' 9" i	23' 5" i	19' 5" i	20' 9"	18' 11"	16' 6"	23' 5" i	21' 3" i	18' 7" i
800PJ300-68	24' 11"	22' 8"	19' 9"	28' 1"	25' 6" i	22' 3" i	22' 8"	20' 7"	18' 0"	25' 6"	23' 2"	20' 3" i
800PJ300-97	28' 3"	25' 8"	22' 5"	31' 9"	28' 10"	25' 2"	25' 8"	23' 3"	20' 4"	28' 10"	26' 2"	22' 10"
800PJ300-118	30' 0"	27' 3"	23' 10"	33' 9"	30' 8"	26' 10"	27' 3"	24' 9"	21' 8"	30' 8"	27' 10"	24' 4"
800PJ350-68	25' 4"	23' 0"	20' 1"	28' 6"	25' 11" i	22' 7" i	23' 0"	20' 11"	18' 3"	25' 11"	23' 6"	20' 6" i
800PJ350-97	28' 11"	26' 3"	22' 11"	32' 7"	29' 7"	25' 10"	26' 3"	23' 10"	20' 10"	29' 7"	26' 10"	23' 5"
800PJ350-118	31' 0"	28' 2"	24' 7"	34' 11"	31' 8"	27' 8"	28' 2"	25' 7"	22' 4"	31' 8"	28' 10"	25' 2"
1000PJ250-43	24' 5"	22' 2" e	18' 2" e	23' 5" i	19' 3" i	14' 3" i	22' 2"	20' 2" e	17' 7" e	23' 5" i	19' 3" i	14' 3" i
1000PJ250-54	26' 9"	24' 4"	21' 3" e	30' 2" i	25' 11" i	20' 4" i	24' 4"	22' 1"	19' 4"	27' 5" i	24' 10" i	20' 4" i
1000PJ250-68	29' 0"	26' 4"	23' 0"	32' 8"	29' 8" i	25' 11" i	26' 4"	23' 11"	20' 11"	29' 8"	26' 11"	23' 6" i
1000PJ250-97	32' 6"	29' 6"	25' 10"	36' 7"	33' 3"	29' 0"	29' 6"	26' 10"	23' 5"	33' 3"	30' 2"	26' 4"
1000PJ250-118	34' 7"	31' 5"	27' 6"	38' 11"	35' 4"	30' 11"	31' 5"	28' 7"	24' 11"	35' 4"	32' 2"	28' 1"
1000PJ300-54	27' 3"	24' 9"	21' 7" e	30' 7" i	26' 0" i	20' 5" i	24' 9"	22' 6"	19' 7"	27' 10" i	25' 3" i	20' 5" i
1000PJ300-68	29' 8"	27' 0"	23' 7"	33' 5" i	30' 4" i	26' 6" i	27' 0"	24' 6"	21' 5"	30' 4"	27' 7" i	24' 1" i
1000PJ300-97	33' 7"	30' 6"	26' 8"	37' 10"	34' 4"	30' 0"	30' 6"	27' 9"	24' 3"	34' 4"	31' 2"	27' 3"
1000PJ300-118	35' 10"	32' 6"	28' 5"	40' 3"	36' 7"	31' 11"	32' 6"	29' 7"	25' 10"	36' 7"	33' 3"	29' 0"
1000PJ350-68	30' 2"	27' 4"	23' 11"	33' 11" i	30' 9" i	26' 7" i	27' 4"	24' 10"	21' 9"	30' 9"	28' 0" i	24' 5" i
1000PJ350-97	34' 5"	31' 3"	27' 3"	38' 8"	35' 2"	30' 8"	31' 3"	28' 5"	24' 10"	35' 2"	31' 11"	27' 11"
1000PJ350-118	36' 11"	33' 6"	29' 3"	41' 6"	37' 9"	32' 11"	33' 6"	30' 6"	26' 7"	37' 9"	34' 3"	29' 11"
1200PJ250-54	30' 2"	27' 5"	23' 5" e	31' 5" i	26' 4" i	20' 3" i	27' 5"	24' 11"	21' 9" e	30' 10" i	26' 4" i	20' 3" i
1200PJ250-68	33' 1"	30' 1"	26' 3"	37' 3" i	33' 9" i	26' 11" i	30' 1"	27' 4"	23' 10"	33' 10" i	30' 9" i	26' 10" i
1200PJ250-97	37' 6"	34' 1"	29' 9"	42' 3"	38' 4"	33' 6" i	34' 1"	31' 0"	27' 1"	38' 4"	34' 10"	30' 5"
1200PJ250-118	40' 1"	36' 5"	31' 10"	45' 2"	41' 0"	35' 10"	36' 5"	33' 1"	28' 11"	41' 0"	37' 3"	32' 6"
1200PJ300-54	31' 0"	28' 2"	23' 10" e	32' 1" i	26' 11" i	20' 7" i	28' 2"	25' 7"	22' 4" e	31' 8" i	26' 11" i	20' 7" i
1200PJ300-68	34' 4"	31' 2"	27' 3"	38' 7" i	35' 1" i	28' 0" i	31' 2"	28' 4"	24' 9"	35' 1" i	31' 10" i	27' 10" i
1200PJ300-97	38' 10"	35' 4"	30' 10"	43' 8"	39' 8"	34' 8" i	35' 4"	32' 1"	28' 0"	39' 8"	36' 1"	31' 6"
1200PJ300-118	41' 5"	37' 7"	32' 10"	46' 7"	42' 4"	36' 11"	37' 7"	34' 2"	29' 10"	42' 4"	38' 5"	33' 7"
1200PJ350-68	34' 9"	31' 7"	27' 7"	39' 2" i	35' 4" i	28' 1" i	31' 7"	28' 8"	25' 1"	35' 7" i	32' 4" i	28' 1" i
1200PJ350-97	39' 8"	36' 1"	31' 6"	44' 8"	40' 7"	35' 5" i	36' 1"	32' 9"	28' 7"	40' 7"	36' 10"	32' 2"
1200PJ350-118	42' 7"	38' 8"	33' 10"	47' 11"	43' 6"	38' 0"	38' 8"	35' 2"	30' 9"	43' 6"	39' 7"	34' 7"
1400PJ250-54	33' 11"	30' 9" e	25' 1" e	32' 2" i	26' 6" i	19' 8" i	30' 9"	28' 0"	24' 5" e	32' 2" i	26' 6" i	19' 8" i
1400PJ250-68	37' 2"	33' 9"	29' 6"	41' 10" i	35' 8" i	28' 1" i	33' 9"	30' 8"	26' 10"	38' 0" i	34' 6" i	28' 1" i
1400PJ250-97	42' 4"	38' 5"	33' 7"	47' 7"	43' 3"	37' 9" i	38' 5"	34' 11"	30' 6"	43' 3"	39' 3"	34' 4" i
1400PJ250-118	45' 5"	41' 3"	36' 0"	51' 1"	46' 5"	40' 6"	41' 3"	37' 6"	32' 9"	46' 5"	42' 2"	36' 10"
1400PJ300-54	34' 4"	31' 2" e	25' 8" e	32' 5" i	26' 8" i	19' 9" i	31' 2"	28' 4"	24' 9" e	32' 5" i	26' 8" i	19' 9" i
1400PJ300-68	37' 10"	34' 5"	30' 1"	42' 6" i	36' 1" i	28' 5" i	34' 5"	31' 3"	27' 4"	38' 8" i	35' 2" i	28' 5" i
1400PJ300-97	43' 7"	39' 7"	34' 7"	49' 1"	44' 7"	38' 11" i	39' 7"	36' 0"	31' 5"	44' 7"	40' 6"	35' 4" i
1400PJ300-118	46' 9"	42' 6"	37' 1"	52' 7"	47' 10"	41' 9"	42' 6"	38' 7"	33' 9"	47' 10"	43' 5"	37' 11"

10 psf Dead Load and 30 psf Live Load (continued)												
Section (All 50 ksi)	Live Load Deflection L/360						Live Load Deflection L/480					
	Single Span			Two Equal Spans			Single Span			Two Equal Spans		
	Spacing (in.) o.c.			Spacing (in.) o.c.			Spacing (in.) o.c.			Spacing (in.) o.c.		
	12	16	24	12	16	24	12	16	24	12	16	24
1400PJ350-68	38' 10"	35' 3"	30' 10" e	43' 6" i	36' 11" i	29' 0" i	35' 3"	32' 1"	28' 0"	39' 8" i	36' 1" i	29' 0" i
1400PJ350-97	44' 10"	40' 9"	35' 7"	50' 6"	45' 10"	40' 1" i	40' 9"	37' 0"	32' 4"	45' 10"	41' 8"	36' 5" i
1400PJ350-118	48' 2"	43' 9"	38' 3"	54' 2"	49' 3"	43' 0"	43' 9"	39' 9"	34' 9"	49' 3"	44' 9"	39' 1"
1600PJ250-68	41' 2"	37' 4"	31' 6" e	43' 10" i	36' 11" i	28' 7" i	37' 4"	33' 11"	29' 8" e	42' 0" i	36' 11" i	28' 7" i
1600PJ250-97	46' 11"	42' 7"	37' 3"	52' 9"	47' 11" i	41' 11" i	42' 7"	38' 9"	33' 10"	47' 11"	43' 7"	38' 1" i
1600PJ250-118	50' 5"	45' 10"	40' 0"	56' 9"	51' 7"	45' 0" i	45' 10"	41' 8"	36' 4"	51' 7"	46' 10"	40' 11"
1600PJ300-68	41' 10"	38' 0"	32' 5" e	44' 3" i	37' 3" i	28' 10" i	38' 0"	34' 6"	30' 2" e	42' 9" i	37' 3" i	28' 10" i
1600PJ300-97	48' 4"	43' 11"	38' 4"	54' 4"	49' 4" i	43' 1" i	43' 11"	39' 10"	34' 10"	49' 4"	44' 10"	39' 2" i
1600PJ300-118	51' 11"	47' 2"	41' 2"	58' 4"	53' 0"	46' 4" i	47' 2"	42' 10"	37' 5"	53' 0"	48' 2"	42' 1"
1600PJ350-68	42' 3"	38' 5"	33' 0" e	44' 7" i	37' 6" i	28' 11" i	38' 5"	34' 10"	30' 5" e	43' 2" i	37' 6" i	28' 11" i
1600PJ350-97	49' 2"	44' 8"	39' 0"	55' 4"	50' 3" i	43' 6" i	44' 8"	40' 7"	35' 6"	50' 3"	45' 8"	39' 11" i
1600PJ350-118	53' 3"	48' 5"	42' 3"	59' 11"	54' 5"	47' 7" i	48' 5"	44' 0"	38' 5"	54' 5"	49' 5"	43' 2"

Refer to Important Table Notes on Page 82

10 psf Dead Load and 40 psf Live Load												
Section (All 50 ksi)	Live Load Deflection L/360						Live Load Deflection L/480					
	Single Span			Two Equal Spans			Single Span			Two Equal Spans		
	Spacing (in.) o.c.			Spacing (in.) o.c.			Spacing (in.) o.c.			Spacing (in.) o.c.		
	12	16	24	12	16	24	12	16	24	12	16	24
600PJ250-43	15' 1"	13' 8"	11' 11" e	16' 11" i	15' 5" i	12' 4" i	13' 8"	12' 5"	10' 10"	15' 5" i	14' 0" i	12' 2" i
600PJ250-54	16' 3"	14' 10"	12' 11"	18' 4" i	16' 8" i	14' 6" i	14' 10"	13' 5"	11' 9"	16' 8"	15' 1" i	13' 2" i
600PJ250-68	17' 8"	16' 0"	14' 0"	19' 10"	18' 0"	15' 9" i	16' 0"	14' 7"	12' 8"	18' 0"	16' 4"	14' 4" i
600PJ250-97	19' 8"	17' 11"	15' 8"	22' 2"	20' 2"	17' 7"	17' 11"	16' 3"	14' 2"	20' 2"	18' 4"	16' 0"
600PJ250-118	20' 11"	19' 0"	16' 7"	23' 7"	21' 5"	18' 8"	19' 0"	17' 3"	15' 1"	21' 5"	19' 5"	17' 0"
600PJ300-54	16' 8"	15' 1"	13' 2"	18' 9" i	17' 0" i	14' 10" i	15' 1"	13' 9"	12' 0"	17' 0"	15' 5" i	13' 6" i
600PJ300-68	18' 2"	16' 6"	14' 5"	20' 5"	18' 6"	16' 2" i	16' 6"	15' 0"	13' 1"	18' 6"	16' 10"	14' 8" i
600PJ300-97	20' 6"	18' 7"	16' 3"	23' 1"	20' 11"	18' 4"	18' 7"	16' 11"	14' 9"	20' 11"	19' 0"	16' 7"
600PJ300-118	21' 10"	19' 10"	17' 3"	24' 6"	22' 3"	19' 5"	19' 10"	18' 0"	15' 8"	22' 3"	20' 3"	17' 8"
600PJ350-68	18' 5"	16' 9"	14' 8"	20' 9"	18' 10"	16' 6" i	16' 9"	15' 3"	13' 4"	18' 10"	17' 2"	15' 0" i
600PJ350-97	21' 1"	19' 2"	16' 9"	23' 9"	21' 7"	18' 10"	19' 2"	17' 5"	15' 2"	21' 7"	19' 7"	17' 1"
600PJ350-118	22' 7"	20' 6"	17' 11"	25' 5"	23' 1"	20' 2"	20' 6"	18' 8"	16' 3"	23' 1"	21' 0"	18' 4"
800PJ250-43	18' 10"	17' 2" e	14' 5" e	19' 10" i	16' 7" i	12' 8" i	17' 2"	15' 7"	13' 7" e	19' 3" i	16' 7" i	12' 8" i
800PJ250-54	20' 5"	18' 6"	16' 2"	22' 11" i	20' 10" i	17' 1" i	18' 6"	16' 10"	14' 8"	20' 10" i	18' 11" i	16' 6" i
800PJ250-68	22' 1"	20' 1"	17' 6"	24' 10"	22' 7" i	19' 9" i	20' 1"	18' 3"	15' 11"	22' 7"	20' 6"	17' 11" i
800PJ250-97	24' 9"	22' 5"	19' 7"	27' 10"	25' 3"	22' 1"	22' 5"	20' 5"	17' 10"	25' 3"	22' 11"	20' 0"
800PJ250-118	26' 4"	23' 11"	20' 10"	29' 7"	26' 11"	23' 6"	23' 11"	21' 8"	18' 11"	26' 11"	24' 5"	21' 4"
800PJ300-54	20' 9"	18' 11"	16' 6"	23' 5" i	21' 3" i	17' 1" i	18' 11"	17' 2"	15' 0"	21' 3" i	19' 4" i	16' 10" i
800PJ300-68	22' 8"	20' 7"	18' 0"	25' 6"	23' 2" i	20' 3" i	20' 7"	18' 8"	16' 4"	23' 2"	21' 0"	18' 4" i
800PJ300-97	25' 8"	23' 3"	20' 4"	28' 10"	26' 2"	22' 10"	23' 3"	21' 2"	18' 6"	26' 2"	23' 9"	20' 9"
800PJ300-118	27' 3"	24' 9"	21' 8"	30' 8"	27' 10"	24' 4"	24' 9"	22' 6"	19' 8"	27' 10"	25' 4"	22' 1"
800PJ350-68	23' 0"	20' 11"	18' 3"	25' 11"	23' 6" i	20' 6" i	20' 11"	19' 0"	16' 7"	23' 6"	21' 4"	18' 8" i
800PJ350-97	26' 3"	23' 10"	20' 10"	29' 7"	26' 10"	23' 5"	23' 10"	21' 8"	18' 11"	26' 10"	24' 5"	21' 4"
800PJ350-118	28' 2"	25' 7"	22' 4"	31' 8"	28' 10"	25' 2"	25' 7"	23' 3"	20' 4"	28' 10"	26' 2"	22' 10"
1000PJ250-43	22' 2" e	19' 11" e	16' 3" e	20' 1" i	16' 4" i	11' 11" i	20' 2"	18' 3" e	16' 0" e	20' 1" i	16' 4" i	11' 11" i
1000PJ250-54	24' 4"	22' 1"	19' 1" e	26' 11" i	22' 9" i	17' 8" i	22' 1"	20' 1"	17' 6" e	24' 10" i	22' 7" i	17' 8" i
1000PJ250-68	26' 4"	23' 11"	20' 11"	29' 8" i	26' 11" i	23' 4" i	23' 11"	21' 9"	19' 0"	26' 11"	24' 6" i	21' 5" i
1000PJ250-97	29' 6"	26' 10"	23' 5"	33' 3"	30' 2"	26' 4"	26' 10"	24' 4"	21' 3"	30' 2"	27' 5"	23' 11"
1000PJ250-118	31' 5"	28' 7"	24' 11"	35' 4"	32' 2"	28' 1"	28' 7"	25' 11"	22' 8"	32' 2"	29' 2"	25' 6"
1000PJ300-54	24' 9"	22' 6"	19' 5" e	27' 0" i	22' 10" i	17' 9" i	22' 6"	20' 5"	17' 10" e	25' 3" i	22' 10" i	17' 9" i
1000PJ300-68	27' 0"	24' 6"	21' 5"	30' 4" i	27' 7" i	23' 6" i	24' 6"	22' 3"	19' 5"	27' 7"	25' 0" i	21' 10" i
1000PJ300-97	30' 6"	27' 9"	24' 3"	34' 4"	31' 2"	27' 3" i	27' 9"	25' 2"	22' 0"	31' 2"	28' 4"	24' 9"
1000PJ300-118	32' 6"	29' 7"	25' 10"	36' 7"	33' 3"	29' 0"	29' 7"	26' 10"	23' 5"	33' 3"	30' 2"	26' 4"
1000PJ350-68	27' 4"	24' 10"	21' 9"	30' 9" i	28' 0" i	23' 6" i	24' 10"	22' 7"	19' 9"	28' 0"	25' 5" i	22' 2" i
1000PJ350-97	31' 3"	28' 5"	24' 10"	35' 2"	31' 11"	27' 11" i	28' 5"	25' 9"	22' 6"	31' 11"	29' 0"	25' 4"
1000PJ350-118	33' 6"	30' 6"	26' 7"	37' 9"	34' 3"	29' 11"	30' 6"	27' 8"	24' 2"	34' 3"	31' 2"	27' 2"

10 psf Dead Load and 40 psf Live Load (continued)												
Section (All 50 ksi)	Live Load Deflection L/360						Live Load Deflection L/480					
	Single Span			Two Equal Spans			Single Span			Two Equal Spans		
	Spacing (in.) o.c.			Spacing (in.) o.c.			Spacing (in.) o.c.			Spacing (in.) o.c.		
	12	16	24	12	16	24	12	16	24	12	16	24
1200PJ250-54	27' 5"	24' 11" e	20' 11" e	27' 5" i	22' 10" i	17' 3" i	24' 11"	22' 8"	19' 9" e	27' 5" i	22' 10" i	17' 3" i
1200PJ250-68	30' 1"	27' 4"	23' 10"	33' 10" i	29' 10" i	23' 8" i	27' 4"	24' 10"	21' 8"	30' 9" i	27' 11" i	23' 8" i
1200PJ250-97	34' 1"	31' 0"	27' 1"	38' 4"	34' 10"	30' 5" i	31' 0"	28' 2"	24' 7"	34' 10"	31' 8"	27' 8"
1200PJ250-118	36' 5"	33' 1"	28' 11"	41' 0"	37' 3"	32' 6"	33' 1"	30' 1"	26' 3"	37' 3"	33' 10"	29' 7"
1200PJ300-54	28' 2"	25' 7" e	21' 4" e	28' 0" i	23' 3" i	17' 6" i	25' 7"	23' 3"	20' 3" e	28' 0" i	23' 3" i	17' 6" i
1200PJ300-68	31' 2"	28' 4"	24' 9"	35' 1" i	31' 1" i	24' 7" i	28' 4"	25' 9"	22' 6"	31' 10" i	28' 11" i	24' 7" i
1200PJ300-97	35' 4"	32' 1"	28' 0"	39' 8"	36' 1"	31' 6" i	32' 1"	29' 2"	25' 5"	36' 1"	32' 9"	28' 7"
1200PJ300-118	37' 7"	34' 2"	29' 10"	42' 4"	38' 5"	33' 7"	34' 2"	31' 0"	27' 1"	38' 5"	34' 11"	30' 6"
1200PJ350-68	31' 7"	28' 8"	25' 1" e	35' 7" i	31' 2" i	24' 8" i	28' 8"	26' 1"	22' 9"	32' 4" i	29' 4" i	24' 8" i
1200PJ350-97	36' 1"	32' 9"	28' 7"	40' 7"	36' 10"	32' 2" i	32' 9"	29' 9"	26' 0"	36' 10"	33' 6"	29' 3" i
1200PJ350-118	38' 8"	35' 2"	30' 9"	43' 6"	39' 7"	34' 7"	35' 2"	31' 11"	27' 11"	39' 7"	35' 11"	31' 5"
1400PJ250-54	30' 9" e	27' 6" e	22' 5" e	27' 9" i	22' 7" i	16' 6" i	28' 0"	25' 5" e	22' 2" e	27' 9" i	22' 7" i	16' 6" i
1400PJ250-68	33' 9"	30' 8"	26' 7" e	37' 0" i	31' 4" i	24' 6" i	30' 8"	27' 11"	24' 4" e	34' 6" i	31' 4" i	24' 6" i
1400PJ250-97	38' 5"	34' 11"	30' 6"	43' 3"	39' 3" i	34' 4" i	34' 11"	31' 9"	27' 8"	39' 3"	35' 8"	31' 2" i
1400PJ250-118	41' 3"	37' 6"	32' 9"	46' 5"	42' 2"	36' 10" i	37' 6"	34' 1"	29' 9"	42' 2"	38' 4"	33' 5"
1400PJ300-54	31' 2" e	28' 1" e	22' 11" e	27' 10" i	22' 8" i	16' 7" i	28' 4"	25' 9" e	22' 6" e	27' 10" i	22' 8" i	16' 7" i
1400PJ300-68	34' 5"	31' 3"	27' 3" e	37' 5" i	31' 8" i	24' 8" i	31' 3"	28' 5"	24' 10" e	35' 2" i	31' 8" i	24' 8" i
1400PJ300-97	39' 7"	36' 0"	31' 5"	44' 7"	40' 6" i	35' 4" i	36' 0"	32' 8"	28' 7"	40' 6"	36' 9"	32' 1" i
1400PJ300-118	42' 6"	38' 7"	33' 9"	47' 10"	43' 5"	37' 11" i	38' 7"	35' 1"	30' 8"	43' 5"	39' 5"	34' 5"
1400PJ350-68	35' 3"	32' 1"	27' 8" e	38' 4" i	32' 5" i	25' 2" i	32' 1"	29' 1"	25' 5" e	36' 1" i	32' 5" i	25' 2" i
1400PJ350-97	40' 9"	37' 0"	32' 4"	45' 10"	41' 8" i	36' 5" i	37' 0"	33' 8"	29' 5"	41' 8"	37' 10"	33' 1" i
1400PJ350-118	43' 9"	39' 9"	34' 9"	49' 3"	44' 9"	39' 1" i	39' 9"	36' 1"	31' 6"	44' 9"	40' 7"	35' 6"
1600PJ250-68	37' 4"	33' 11"	28' 2" e	38' 5" i	32' 2" i	24' 7" i	33' 11"	30' 10"	26' 11" e	38' 2" i	32' 2" i	24' 7" i
1600PJ250-97	42' 7"	38' 9"	33' 10"	47' 11"	43' 7" i	38' 0" i	38' 9"	35' 2"	30' 9"	43' 7"	39' 7"	34' 7" i
1600PJ250-118	45' 10"	41' 8"	36' 4"	51' 7"	46' 10"	40' 11" i	41' 8"	37' 10"	33' 0"	46' 10"	42' 7"	37' 2"
1600PJ300-68	38' 0"	34' 6"	28' 11" e	38' 9" i	32' 5" i	24' 9" i	34' 6"	31' 4"	27' 5" e	38' 9" i	32' 5" i	24' 9" i
1600PJ300-97	43' 11"	39' 10"	34' 10"	49' 4" i	44' 10" i	38' 7" i	39' 10"	36' 3"	31' 8"	44' 10"	40' 9" i	35' 7" i
1600PJ300-118	47' 2"	42' 10"	37' 5"	53' 0"	48' 2"	42' 1" i	42' 10"	38' 11"	34' 0"	48' 2"	43' 9"	38' 3"
1600PJ350-68	38' 5"	34' 10"	29' 6" e	39' 0" i	32' 7" i	24' 10" i	34' 10"	31' 8"	27' 8" e	39' 0" i	32' 7" i	24' 10" i
1600PJ350-97	44' 8"	40' 7"	35' 6"	50' 3" i	45' 8" i	38' 7" i	40' 7"	36' 11"	32' 3"	45' 8"	41' 6" i	36' 3" i
1600PJ350-118	48' 5"	44' 0"	38' 5"	54' 5"	49' 5"	43' 2" i	44' 0"	39' 11"	34' 11"	49' 5"	44' 11"	39' 3"

Refer to Important Table Notes on Page 82

10 psf Dead Load and 50 psf Live Load												
Section (All 50 ksi)	Live Load Deflection L/360						Live Load Deflection L/480					
	Single Span			Two Equal Spans			Single Span			Two Equal Spans		
	Spacing (in.) o.c.			Spacing (in.) o.c.			Spacing (in.) o.c.			Spacing (in.) o.c.		
	12	16	24	12	16	24	12	16	24	12	16	24
600PJ250-43	14' 0"	12' 8"	11' 1" e	15' 9" i	14' 1" i	11' 1" i	12' 8"	11' 6"	10' 1" e	14' 3" i	13' 0" i	11' 1" i
600PJ250-54	15' 1"	13' 9"	12' 0"	17' 0" i	15' 5" i	13' 6" i	13' 9"	12' 6"	10' 11"	15' 5"	14' 0" i	12' 3" i
600PJ250-68	16' 4"	14' 10"	13' 0"	18' 5"	16' 9" i	14' 7" i	14' 10"	13' 6"	11' 10"	16' 9"	15' 2"	13' 3" i
600PJ250-97	18' 3"	16' 7"	14' 6"	20' 7"	18' 8"	16' 4"	16' 7"	15' 1"	13' 2"	18' 8"	17' 0"	14' 10"
600PJ250-118	19' 5"	17' 8"	15' 5"	21' 10"	19' 10"	17' 4"	17' 8"	16' 0"	14' 0"	19' 10"	18' 1"	15' 9"
600PJ300-54	15' 5"	14' 0"	12' 3"	17' 4" i	15' 9" i	13' 8" i	14' 0"	12' 9"	11' 1"	15' 9"	14' 4" i	12' 6" i
600PJ300-68	16' 10"	15' 4"	13' 4"	18' 11"	17' 2" i	15' 0" i	15' 4"	13' 11"	12' 2"	17' 2"	15' 8"	13' 8" i
600PJ300-97	19' 0"	17' 3"	15' 1"	21' 5"	19' 5"	17' 0"	17' 3"	15' 8"	13' 9"	19' 5"	17' 8"	15' 5"
600PJ300-118	20' 3"	18' 5"	16' 1"	22' 9"	20' 8"	18' 1"	18' 5"	16' 8"	14' 7"	20' 8"	18' 9"	16' 5"
600PJ350-68	17' 2"	15' 7"	13' 7"	19' 3"	17' 6" i	15' 3" i	15' 7"	14' 2"	12' 4"	17' 6"	15' 11"	13' 11" i
600PJ350-97	19' 7"	17' 9"	15' 6"	22' 0"	20' 0"	17' 6"	17' 9"	16' 2"	14' 1"	20' 0"	18' 2"	15' 10"
600PJ350-118	21' 0"	19' 1"	16' 8"	23' 7"	21' 5"	18' 9"	19' 1"	17' 4"	15' 1"	21' 5"	19' 6"	17' 0"
800PJ250-43	17' 6"	15' 11" e	13' 2" e	17' 9" i	14' 9" i	11' 2" a	15' 11"	14' 5" e	12' 7" e	17' 9" i	14' 9" i	11' 2" a
800PJ250-54	18' 11"	17' 2"	15' 0" e	21' 4" i	19' 4" i	15' 4" i	17' 2"	15' 7"	13' 8"	19' 4" i	17' 7" i	15' 4" i
800PJ250-68	20' 6"	18' 8"	16' 3"	23' 1" i	20' 11" i	18' 4" i	18' 8"	16' 11"	14' 9"	20' 11"	19' 0" i	16' 7" i
800PJ250-97	22' 11"	20' 10"	18' 2"	25' 10"	23' 5"	20' 6"	20' 10"	18' 11"	16' 6"	23' 5"	21' 4"	18' 7"
800PJ250-118	24' 5"	22' 2"	19' 4"	27' 6"	24' 11"	21' 9"	22' 2"	20' 2"	17' 7"	24' 11"	22' 8"	19' 10"

10 psf Dead Load and 50 psf Live Load (continued)												
Section (All 50 ksi)	Live Load Deflection L/360						Live Load Deflection L/480					
	Single Span			Two Equal Spans			Single Span			Two Equal Spans		
	Spacing (in.) o.c.			Spacing (in.) o.c.			Spacing (in.) o.c.			Spacing (in.) o.c.		
	12	16	24	12	16	24	12	16	24	12	16	24
800PJ300-54	19' 3"	17' 6"	15' 4" e	21' 8" i	19' 5" i	15' 4" i	17' 6"	15' 11"	13' 11"	19' 9" i	17' 11" i	15' 4" i
800PJ300-68	21' 0"	19' 1"	16' 8"	23' 8" i	21' 6" i	18' 9" i	19' 1"	17' 4"	15' 2"	21' 6"	19' 6" i	17' 0" i
800PJ300-97	23' 9"	21' 7"	18' 10"	26' 9"	24' 4"	21' 3" i	21' 7"	19' 8"	17' 2"	24' 4"	22' 1"	19' 3"
800PJ300-118	25' 4"	23' 0"	20' 1"	28' 6"	25' 10"	22' 7"	23' 0"	20' 11"	18' 3"	25' 10"	23' 6"	20' 6"
800PJ350-68	21' 4"	19' 5"	16' 11"	24' 0" i	21' 10" i	19' 1" i	19' 5"	17' 7"	15' 5"	21' 10"	19' 10" i	17' 4" i
800PJ350-97	24' 5"	22' 2"	19' 4"	27' 5"	24' 11"	21' 9" i	22' 2"	20' 2"	17' 7"	24' 11"	22' 8"	19' 9"
800PJ350-118	26' 2"	23' 9"	20' 9"	29' 5"	26' 9"	23' 4"	23' 9"	21' 7"	18' 10"	26' 9"	24' 3"	21' 3"
1000PJ250-43	20' 7" e	18' 2" e	14' 0" e	17' 8" i	14' 3" i	10' 2" i	18' 8" e	17' 0" e	14' 0" e	17' 8" i	14' 3" i	10' 2" i
1000PJ250-54	22' 7"	20' 6"	17' 5" e	24' 2" i	20' 4" i	15' 8" i	20' 6"	18' 8"	16' 3" e	23' 1" i	20' 4" i	15' 8" i
1000PJ250-68	24' 6"	22' 3"	19' 5"	27' 6" i	25' 0" i	21' 1" i	22' 3"	20' 2"	17' 8"	25' 0"	22' 9" i	19' 10" i
1000PJ250-97	27' 5"	24' 11"	21' 9"	30' 10"	28' 0"	24' 6" i	24' 11"	22' 7"	19' 9"	28' 0"	25' 5"	22' 3"
1000PJ250-118	29' 2"	26' 6"	23' 2"	32' 10"	29' 10"	26' 1"	26' 6"	24' 1"	21' 0"	29' 10"	27' 1"	23' 8"
1000PJ300-54	22' 11"	20' 10" e	17' 9" e	24' 4" i	20' 5" i	15' 9" i	20' 10"	18' 11"	16' 6" e	23' 5" i	20' 5" i	15' 9" i
1000PJ300-68	25' 0"	22' 9"	19' 10"	28' 2" i	25' 7" i	21' 3" i	22' 9"	20' 8"	18' 0"	25' 7" i	23' 3" i	20' 4" i
1000PJ300-97	28' 4"	25' 9"	22' 6"	31' 11"	29' 0"	25' 4" i	25' 9"	23' 5"	20' 5"	29' 0"	26' 4"	23' 0"
1000PJ300-118	30' 2"	27' 5"	23' 11"	33' 11"	30' 10"	26' 11"	27' 5"	24' 11"	21' 9"	30' 10"	28' 0"	24' 6"
1000PJ350-68	25' 5"	23' 1"	20' 2"	28' 7" i	26' 0" i	21' 3" i	23' 1"	21' 0"	18' 4"	26' 0" i	23' 7" i	20' 7" i
1000PJ350-97	29' 0"	26' 4"	23' 0"	32' 8"	29' 8"	25' 11" i	26' 4"	23' 11"	20' 11"	29' 8"	26' 11"	23' 6"
1000PJ350-118	31' 1"	28' 3"	24' 8"	35' 0"	31' 10"	27' 9"	28' 3"	25' 8"	22' 5"	31' 10"	28' 11"	25' 3"
1200PJ250-54	25' 6"	23' 2" e	19' 1" e	24' 6" i	20' 3" i	15' 1" i	23' 2"	21' 0" e	18' 4" e	24' 6" i	20' 3" i	15' 1" i
1200PJ250-68	27' 11"	25' 4"	22' 2" e	31' 5" i	26' 11" i	21' 3" i	25' 4"	23' 0"	20' 1"	28' 6" i	25' 11" i	21' 3" i
1200PJ250-97	31' 8"	28' 9"	25' 1"	35' 7"	32' 4" i	28' 3" i	28' 9"	26' 1"	22' 10"	32' 4"	29' 5"	25' 8" i
1200PJ250-118	33' 10"	30' 9"	26' 10"	38' 1"	34' 7"	30' 2" i	30' 9"	27' 11"	24' 5"	34' 7"	31' 5"	27' 5"
1200PJ300-54	26' 1"	23' 9" e	19' 6" e	24' 11" i	20' 7" i	15' 3" i	23' 9"	21' 7" e	18' 10" e	24' 11" i	20' 7" i	15' 3" i
1200PJ300-68	28' 11"	26' 3"	22' 11" e	32' 7" i	28' 0" i	22' 1" i	26' 3"	23' 11"	20' 10" e	29' 7" i	26' 10" i	22' 1" i
1200PJ300-97	32' 9"	29' 9"	26' 0"	36' 10"	33' 6" i	29' 3" i	29' 9"	27' 0"	23' 7"	33' 6"	30' 5"	26' 7" i
1200PJ300-118	34' 11"	31' 9"	27' 8"	39' 3"	35' 8"	31' 2"	31' 9"	28' 10"	25' 2"	35' 8"	32' 5"	28' 4"
1200PJ350-68	29' 4"	26' 8"	23' 3" e	33' 0" i	28' 1" i	22' 1" i	26' 8"	24' 2"	21' 2" e	30' 0" i	27' 3" i	22' 1" i
1200PJ350-97	33' 6"	30' 5"	26' 7"	37' 8"	34' 2" i	29' 11" i	30' 5"	27' 7"	24' 2"	34' 2"	31' 1"	27' 2" i
1200PJ350-118	35' 11"	32' 8"	28' 6"	40' 5"	36' 9"	32' 1" i	32' 8"	29' 8"	25' 11"	36' 9"	33' 4"	29' 2"
1400PJ250-54	28' 7" e	25' 1" e	19' 7" e	24' 5" i	19' 8" i	14' 2" i	25' 11" e	23' 7" e	19' 7" e	24' 5" i	19' 8" i	14' 2" i
1400PJ250-68	31' 4"	28' 6"	24' 3" e	33' 4" i	28' 1" i	21' 9" i	28' 6"	25' 11"	22' 7" e	32' 1" i	28' 1" i	21' 9" i
1400PJ250-97	35' 8"	32' 5"	28' 4"	40' 2"	36' 5" i	31' 10" i	32' 5"	29' 5"	25' 9"	36' 5"	33' 1"	28' 11" i
1400PJ250-118	38' 3"	34' 9"	30' 5"	43' 1"	39' 2"	34' 2" i	34' 9"	31' 7"	27' 7"	39' 2"	35' 7"	31' 1"
1400PJ300-54	28' 11" e	25' 8" e	19' 7" e	24' 6" i	19' 9" i	14' 3" i	26' 3" e	23' 11" e	19' 7" e	24' 6" i	19' 9" i	14' 3" i
1400PJ300-68	31' 11"	29' 0"	24' 10" e	33' 8" i	28' 5" i	21' 11" i	29' 0"	26' 4"	23' 0" e	32' 8" i	28' 5" i	21' 11" i
1400PJ300-97	36' 9"	33' 5"	29' 2"	41' 4"	37' 7" i	32' 10" i	33' 5"	30' 4"	26' 6"	37' 7"	34' 2"	29' 10" i
1400PJ300-118	39' 5"	35' 10"	31' 4"	44' 4"	40' 4"	35' 2" i	35' 10"	32' 7"	28' 5"	40' 4"	36' 7"	32' 0"
1400PJ350-68	32' 9"	29' 9"	25' 3" e	34' 6" i	29' 0" i	22' 4" i	29' 9"	27' 0"	23' 7" e	33' 6" i	29' 0" i	22' 4" i
1400PJ350-97	37' 10"	34' 5"	30' 0"	42' 7"	38' 8" i	33' 9" i	34' 5"	31' 3"	27' 3"	38' 8"	35' 2"	30' 8" i
1400PJ350-118	40' 7"	36' 11"	32' 3"	45' 8"	41' 6"	36' 3" i	36' 11"	33' 6"	29' 3"	41' 6"	37' 8"	32' 11"
1600PJ250-68	34' 8"	31' 6" e	25' 9" e	34' 4" i	28' 7" i	21' 7" i	31' 6"	28' 7"	25' 0" e	34' 4" i	28' 7" i	21' 7" i
1600PJ250-97	39' 7"	35' 11"	31' 5"	44' 6" i	40' 5" i	34' 5" i	35' 11"	32' 8"	28' 6"	40' 5"	36' 9" i	32' 1" i
1600PJ250-118	42' 6"	38' 8"	33' 9"	47' 10"	43' 6"	38' 0" i	38' 8"	35' 1"	30' 8"	43' 6"	39' 6"	34' 6" i
1600PJ300-68	35' 3"	32' 1" e	26' 5" e	34' 8" i	28' 10" i	21' 9" i	32' 1"	29' 1"	25' 5" e	34' 8" i	28' 10" i	21' 9" i
1600PJ300-97	40' 9"	37' 0"	32' 4"	45' 10" i	41' 7" i	34' 11" i	37' 0"	33' 7"	29' 4"	41' 7"	37' 10" i	33' 0" i
1600PJ300-118	43' 9"	39' 9"	34' 9"	49' 3"	44' 9"	39' 1" i	39' 9"	36' 1"	31' 7"	44' 9"	40' 8"	35' 6" i
1600PJ350-68	35' 7"	32' 4" e	26' 11" e	34' 10" i	28' 11" i	21' 10" i	32' 4"	29' 5" e	25' 8" e	34' 10" i	28' 11" i	21' 10" i
1600PJ350-97	41' 6"	37' 8"	32' 11"	46' 8" i	42' 5" i	34' 11" i	37' 8"	34' 3"	29' 11"	42' 5"	38' 6" i	33' 8" i
1600PJ350-118	44' 11"	40' 10"	35' 8"	50' 6"	45' 11" i	40' 1" i	40' 10"	37' 1"	32' 5"	45' 11"	41' 8"	36' 5" i

Floor Systems

Allowable Floor Joist Span Tables

Refer to Important Table Notes on Page 82

15 psf Dead Load and 125 psf Live Load												
Section (All 50 ksi)	Live Load Deflection L/360						Live Load Deflection L/480					
	Single Span			Two Equal Spans			Single Span			Two Equal Spans		
	Spacing (in.) o.c.			Spacing (in.) o.c.			Spacing (in.) o.c.			Spacing (in.) o.c.		
	12	16	24	12	16	24	12	16	24	12	16	24
600PJ250-43	10' 3" e	9' 0" e	7' 4" e	10' 1" a	8' 5" a	6' 4" a	9' 4" e	8' 6" e	7' 4" e	10' 1" a	8' 5" a	6' 4" a
600PJ250-54	11' 2"	10' 1" e	8' 7" e	12' 5" i	10' 7" i	8' 5" a	10' 1"	9' 2"	8' 0" e	11' 5" i	10' 4" i	8' 5" a
600PJ250-68	12' 1"	10' 11"	9' 7"	13' 7" i	12' 4" i	10' 1" i	10' 11"	9' 11"	8' 8"	12' 4" i	11' 2" i	9' 9" i
600PJ250-97	13' 6"	12' 3"	10' 8"	15' 2"	13' 9"	12' 0" i	12' 3"	11' 1"	9' 8"	13' 9"	12' 6"	10' 11" i
600PJ250-118	14' 4"	13' 0"	11' 4"	16' 1"	14' 8"	12' 9"	13' 0"	11' 10"	10' 4"	14' 8"	13' 3"	11' 7"
600PJ300-54	11' 4"	10' 4" e	8' 10" e	12' 7" i	10' 9" i	8' 6" a	10' 4"	9' 4"	8' 2" e	11' 7" i	10' 7" i	8' 6" a
600PJ300-68	12' 5"	11' 3"	9' 10" e	13' 11" i	12' 8" i	10' 3" i	11' 3"	10' 3"	8' 11"	12' 8" i	11' 6" i	10' 1" i
600PJ300-97	14' 0"	12' 9"	11' 1"	15' 9"	14' 4" i	12' 6" i	12' 9"	11' 7"	10' 1"	14' 4"	13' 0"	11' 4" i
600PJ300-118	14' 11"	13' 6"	11' 10"	16' 9"	15' 3"	13' 4"	13' 6"	12' 3"	10' 9"	15' 3"	13' 10"	12' 1"
600PJ350-68	12' 7"	11' 5"	10' 0" e	14' 2" i	12' 11" i	10' 5" i	11' 5"	10' 5"	9' 1"	12' 11" i	11' 8" i	10' 3" i
600PJ350-97	14' 5"	13' 1"	11' 5"	16' 3"	14' 9" i	12' 10" i	13' 1"	11' 11"	10' 5"	14' 9"	13' 4"	11' 8" i
600PJ350-118	15' 5"	14' 0"	12' 3"	17' 4"	15' 9"	13' 9" i	14' 0"	12' 9"	11' 1"	15' 9"	14' 4"	12' 6"
800PJ250-43	12' 3" e	10' 7" e	7' 6" e	9' 11" a	7' 11" a	5' 7" a	11' 8" e	10' 7" e	7' 6" e	9' 11" a	7' 11" a	5' 7" a
800PJ250-54	13' 11" e	12' 5" e	10' 1" e	14' 0" i	11' 8" a	8' 11" a	12' 8" e	11' 6" e	10' 0" e	14' 0" i	11' 8" a	8' 11" a
800PJ250-68	15' 1"	13' 9"	11' 11" e	17' 0" i	14' 10" i	11' 10" a	13' 9"	12' 5"	10' 11" e	15' 5" i	14' 0" i	11' 10" a
800PJ250-97	16' 11"	15' 4"	13' 5"	19' 0"	17' 3" i	15' 1" i	15' 4"	13' 11"	12' 2"	17' 3"	15' 8"	13' 8" i
800PJ250-118	18' 0"	16' 4"	14' 3"	20' 3"	18' 4"	16' 1" i	16' 4"	14' 10"	12' 11"	18' 4"	16' 8"	14' 7"
800PJ300-54	14' 2" e	12' 7" e	10' 4" e	14' 0" i	11' 9" a	8' 11" a	12' 11" e	11' 9" e	10' 3" e	14' 0" i	11' 9" a	8' 11" a
800PJ300-68	15' 6"	14' 1"	12' 1" e	17' 5" i	15' 1" i	12' 0" a	14' 1"	12' 9"	11' 2" e	15' 10" i	14' 4" i	12' 0" a
800PJ300-97	17' 6"	15' 11"	13' 11"	19' 8" i	17' 11" i	15' 8" i	15' 11"	14' 5"	12' 7"	17' 11"	16' 3" i	14' 2" i
800PJ300-118	18' 8"	16' 11"	14' 9"	21' 0"	19' 1"	16' 8" i	16' 11"	15' 5"	13' 5"	19' 1"	17' 4"	15' 1"
800PJ350-68	15' 9"	14' 3" e	12' 3" e	17' 8" i	15' 3" i	12' 2" a	14' 3"	13' 0"	11' 4" e	16' 1" i	14' 7" i	12' 2" a
800PJ350-97	18' 0"	16' 4"	14' 3"	20' 2" i	18' 4" i	15' 11" i	16' 4"	14' 10"	12' 11"	18' 4"	16' 8" i	14' 7" i
800PJ350-118	19' 3"	17' 6"	15' 3"	21' 8"	19' 8"	17' 2" i	17' 6"	15' 11"	13' 11"	19' 8"	17' 11"	15' 7" i
1000PJ250-43	12' 0" e	9' 0" e	6' 0" e	8' 11" a	6' 10" a	4' 8" a	12' 0" e	9' 0" e	6' 0" e	8' 11" a	6' 10" a	4' 8" a
1000PJ250-54	16' 2" e	14' 0" e	11' 5" e	14' 2" a	11' 6" a	8' 4" a	15' 1" e	13' 9" e	11' 5" e	14' 2" a	11' 6" a	8' 4" a
1000PJ250-68	18' 0"	16' 4" e	13' 5" e	19' 4" i	16' 4" a	12' 8" a	16' 4"	14' 10" e	13' 0" e	18' 5" i	16' 4" a	12' 8" a
1000PJ250-97	20' 2"	18' 4"	16' 0"	22' 9" i	20' 8" i	18' 0" i	18' 4"	16' 8"	14' 7"	20' 8"	18' 9" i	16' 4" i
1000PJ250-118	21' 6"	19' 6"	17' 1"	24' 2"	22' 0" i	19' 2" i	19' 6"	17' 9"	15' 6"	22' 0"	19' 11"	17' 5" i
1000PJ300-54	16' 5" e	14' 3" e	11' 7" e	14' 2" a	11' 6" a	8' 5" a	15' 4" e	13' 11" e	11' 7" e	14' 2" a	11' 6" a	8' 5" a
1000PJ300-68	18' 5" e	16' 9" e	13' 8" e	19' 5" i	16' 5" a	12' 9" a	16' 9"	15' 3" e	13' 3" e	18' 10" i	16' 5" a	12' 9" a
1000PJ300-97	20' 10"	19' 0"	16' 7"	23' 6" i	21' 4" i	18' 3" i	19' 0"	17' 3"	15' 0"	21' 4" i	19' 5" i	16' 11" i
1000PJ300-118	22' 3"	20' 2"	17' 8"	25' 0"	22' 9" i	19' 10" i	20' 2"	18' 4"	16' 0"	22' 9"	20' 8"	18' 0" i
1000PJ350-68	18' 8" e	17' 0" e	13' 10" e	19' 5" i	16' 5" a	12' 9" a	17' 0"	15' 5" e	13' 6" e	19' 1" i	16' 5" a	12' 9" a
1000PJ350-97	21' 4"	19' 5"	16' 11"	24' 0" i	21' 10" i	18' 4" i	19' 5"	17' 7"	15' 5"	21' 10" i	19' 10" i	17' 4" i
1000PJ350-118	22' 11"	20' 10"	18' 2"	25' 9"	23' 5" i	20' 5" i	20' 10"	18' 11"	16' 6"	23' 5"	21' 3"	18' 7" i
1200PJ250-54	17' 8" e	14' 9" e	9' 10" e	13' 5" a	10' 7" a	7' 5" a	17' 0" e	14' 9" e	9' 10" e	13' 5" a	10' 7" a	7' 5" a
1200PJ250-68	20' 7" e	18' 1" e	14' 9" e	19' 4" i	16' 2" a	12' 3" a	18' 8" e	16' 11" e	14' 9" e	19' 4" i	16' 2" a	12' 3" a
1200PJ250-97	23' 4"	21' 2"	18' 6" e	26' 3" i	23' 10" i	19' 2" i	21' 2"	19' 3"	16' 10"	23' 10" i	21' 8" i	18' 11" i
1200PJ250-118	24' 11"	22' 8"	19' 9"	28' 0" i	25' 6" i	22' 2" i	22' 8"	20' 7"	17' 11"	25' 6"	23' 2" i	20' 2" i
1200PJ300-54	18' 0" e	14' 9" e	9' 10" e	13' 7" a	10' 8" a	7' 6" a	17' 6" e	14' 9" e	9' 10" e	13' 7" a	10' 8" a	7' 6" a
1200PJ300-68	21' 4" e	18' 6" e	15' 1" e	20' 1" i	16' 8" a	12' 7" a	19' 4" e	17' 7" e	15' 1" e	20' 1" i	16' 8" a	12' 7" a
1200PJ300-97	24' 2"	21' 11"	19' 2" e	27' 2" i	24' 8" i	20' 2" i	21' 11"	19' 11"	17' 5" e	24' 8" i	22' 5" i	19' 7" i
1200PJ300-118	25' 9"	23' 4"	20' 5"	28' 11"	26' 3" i	22' 11" i	23' 4"	21' 3"	18' 6"	26' 3"	23' 10"	20' 10" i
1200PJ350-68	21' 7" e	18' 9" e	15' 3" e	20' 1" i	16' 8" a	12' 7" a	19' 7" e	17' 10" e	15' 3" e	20' 1" i	16' 8" a	12' 7" a
1200PJ350-97	24' 8"	22' 5"	19' 7" e	27' 9" i	25' 2" i	20' 4" a	22' 5"	20' 4"	17' 9" e	25' 2" i	22' 11" i	20' 0" i
1200PJ350-118	26' 6"	24' 0"	21' 0"	29' 9" i	27' 0" i	23' 7" i	24' 0"	21' 10"	19' 1"	27' 0"	24' 7" i	21' 5" i
1400PJ250-54	16' 10" e	12' 7" e	8' 5" e	12' 5" i	9' 7" a	6' 7" a	16' 10" e	12' 7" e	8' 5" e	12' 5" i	9' 7" a	6' 7" a
1400PJ250-68	22' 6" e	19' 6" e	15' 11" e	19' 7" i	16' 0" a	11' 9" a	21' 0" e	19' 1" e	15' 11" e	19' 7" i	16' 0" a	11' 9" a
1400PJ250-97	26' 3"	23' 10"	20' 7" e	29' 7" i	25' 7" i	20' 4" a	23' 10"	21' 8"	18' 11" e	26' 10" i	24' 5" i	20' 4" a
1400PJ250-118	28' 2"	25' 7"	22' 4"	31' 9" i	28' 10" i	24' 0" i	25' 7"	23' 3"	20' 4"	28' 10"	26' 2" i	22' 10" i
1400PJ300-54	16' 10" e	12' 7" e	8' 5" e	12' 5" i	9' 7" a	6' 7" a	16' 10" e	12' 7" e	8' 5" e	12' 5" i	9' 7" a	6' 7" a
1400PJ300-68	23' 0" e	19' 11" e	16' 3" e	19' 9" i	16' 1" a	11' 9" a	21' 4" e	19' 5" e	16' 3" e	19' 9" i	16' 1" a	11' 9" a
1400PJ300-97	27' 1"	24' 7"	21' 1" e	30' 4" i	25' 11" i	20' 7" a	24' 7"	22' 4"	19' 6" e	27' 8" i	25' 2" i	20' 7" a
1400PJ300-118	29' 1"	26' 5"	23' 1"	32' 8" i	29' 8" i	24' 9" i	26' 5"	24' 0"	20' 11"	29' 8" i	27' 0" i	23' 7" i

15 psf Dead Load and 125 psf Live Load (continued)												
Section (All 50 ksi)	Live Load Deflection L/360						Live Load Deflection L/480					
	Single Span			Two Equal Spans			Single Span			Two Equal Spans		
	Spacing (in.) o.c.			Spacing (in.) o.c.			Spacing (in.) o.c.			Spacing (in.) o.c.		
	12	16	24	12	16	24	12	16	24	12	16	24
1400PJ350-68	23' 4" e	20' 3" e	16' 6" e	20' 1" a	16' 4" a	11' 11" a	21' 11" e	19' 11" e	16' 6" e	20' 1" a	16' 4" a	11' 11" a
1400PJ350-97	27' 10"	25' 4"	21' 6" e	31' 4" i	27' 4" i	21' 8" a	25' 4"	23' 0"	20' 1" e	28' 6" i	25' 10" i	21' 8" a
1400PJ350-118	29' 11"	27' 2"	23' 9"	33' 8" i	30' 7" i	26' 4" i	27' 2"	24' 8"	21' 7"	30' 7"	27' 9" i	24' 3" i
1600PJ250-68	23' 10" e	20' 7" e	14' 8" e	19' 3" i	15' 5" a	10' 11" a	23' 2" e	20' 7" e	14' 8" e	19' 3" i	15' 5" a	10' 11" a
1600PJ250-97	29' 2"	26' 6" e	22' 0" e	31' 7" i	26' 10" i	21' 0" a	26' 6"	24' 1"	21' 0" e	29' 9" i	26' 10" i	21' 0" a
1600PJ250-118	31' 4"	28' 6"	24' 10" e	35' 3" i	31' 10" i	25' 7" i	28' 6"	25' 10"	22' 7"	32' 0" i	29' 1" i	25' 5" i
1600PJ300-68	24' 6" e	21' 2" e	14' 8" e	19' 5" i	15' 5" a	10' 11" a	23' 7" e	21' 2" e	14' 8" e	19' 5" i	15' 5" a	10' 11" a
1600PJ300-97	30' 0"	27' 3" e	22' 7" e	32' 0" i	27' 2" i	21' 4" a	27' 3"	24' 9"	21' 7" e	30' 8" i	27' 2" i	21' 4" a
1600PJ300-118	32' 3"	29' 3"	25' 7" e	36' 3" i	32' 9" i	26' 4" i	29' 3"	26' 7"	23' 3"	32' 11" i	29' 11" i	26' 2" i
1600PJ350-68	24' 11" e	21' 7" e	14' 8" e	19' 5" i	15' 6" a	10' 11" a	23' 10" e	21' 7" e	14' 8" e	19' 5" i	15' 6" a	10' 11" a
1600PJ350-97	30' 7"	27' 9" e	23' 0" e	32' 0" i	27' 2" i	21' 4" a	27' 9"	25' 3" e	22' 0" e	31' 3" i	27' 2" i	21' 4" a
1600PJ350-118	33' 1"	30' 1"	26' 3" e	37' 3" i	33' 7" i	26' 11" i	30' 1"	27' 4"	23' 10"	33' 10" i	30' 9" i	26' 10" i

Refer to Important Table Notes on Page 82

40 psf Dead Load and 125 psf Live Load												
Section (All 50 ksi)	Live Load Deflection L/360						Live Load Deflection L/480					
	Single Span			Two Equal Spans			Single Span			Two Equal Spans		
	Spacing (in.) o.c.			Spacing (in.) o.c.			Spacing (in.) o.c.			Spacing (in.) o.c.		
	12	16	24	12	16	24	12	16	24	12	16	24
600PJ250-43	9' 7" e	8' 4" e	6' 9" e	9' 1" a	7' 6" a	5' 7" a	9' 4" e	8' 4" e	6' 9" e	9' 1" a	7' 6" a	5' 7" a
600PJ250-54	11' 2" e	9' 9" e	7' 11" e	11' 4" i	9' 8" a	7' 8" a	10' 1"	9' 2" e	7' 11" e	11' 4" i	9' 8" a	7' 8" a
600PJ250-68	12' 1"	10' 11"	9' 3" e	13' 4" i	11' 5" i	9' 3" i	10' 11"	9' 11"	8' 8" e	12' 4" i	11' 2" i	9' 3" i
600PJ250-97	13' 6"	12' 3"	10' 8"	15' 2"	13' 9" i	12' 0" i	12' 3"	11' 1"	9' 8"	13' 9"	12' 6"	10' 11" i
600PJ250-118	14' 4"	13' 0"	11' 4"	16' 1"	14' 8"	12' 9" i	13' 0"	11' 10"	10' 4"	14' 8"	13' 3"	11' 7"
600PJ300-54	11' 4" e	9' 11" e	8' 1" e	11' 6" i	9' 10" a	7' 9" a	10' 4"	9' 4" e	8' 1" e	11' 6" i	9' 10" a	7' 9" a
600PJ300-68	12' 5"	11' 3"	9' 6" e	13' 7" i	11' 8" i	9' 5" i	11' 3"	10' 3"	8' 11" e	12' 8" i	11' 6" i	9' 5" i
600PJ300-97	14' 0"	12' 9"	11' 1"	15' 9" i	14' 4" i	12' 1" i	12' 9"	11' 7"	10' 1"	14' 4"	13' 0" i	11' 4" i
600PJ300-118	14' 11"	13' 6"	11' 10"	16' 9"	15' 3"	13' 4" i	13' 6"	12' 3"	10' 9"	15' 3"	13' 10"	12' 1"
600PJ350-68	12' 7"	11' 5"	9' 8" e	13' 9" i	11' 10" i	9' 6" i	11' 5"	10' 5"	9' 1" e	12' 11" i	11' 8" i	9' 6" i
600PJ350-97	14' 5"	13' 1"	11' 5"	16' 3" i	14' 9" i	12' 2" i	13' 1"	11' 11"	10' 5"	14' 9"	13' 4" i	11' 8" i
600PJ350-118	15' 5"	14' 0"	12' 3"	17' 4"	15' 9" i	13' 9" i	14' 0"	12' 9"	11' 1"	15' 9"	14' 4"	12' 6" i
800PJ250-43	11' 3" e	9' 7" e	6' 5" e	8' 9" a	6' 11" a	4' 10" a	11' 3" e	9' 7" e	6' 5" e	8' 9" a	6' 11" a	4' 10" a
800PJ250-54	13' 2" e	11' 5" e	9' 4" e	12' 8" a	10' 6" a	7' 11" a	12' 8" e	11' 5" e	9' 4" e	12' 8" a	10' 6" a	7' 11" a
800PJ250-68	15' 1"	13' 5" e	10' 11" e	15' 10" i	13' 6" i	10' 9" a	13' 9"	12' 5" e	10' 11" e	15' 5" i	13' 6" i	10' 9" a
800PJ250-97	16' 11"	15' 4"	13' 5"	19' 0" i	17' 3" i	14' 10" i	15' 4"	13' 11"	12' 2"	17' 3"	15' 8" i	13' 8" i
800PJ250-118	18' 0"	16' 4"	14' 3"	20' 3" i	18' 4" i	16' 1" i	16' 4"	14' 10"	12' 11"	18' 4"	16' 8" i	14' 7" i
800PJ300-54	13' 5" e	11' 7" e	9' 6" e	12' 8" a	10' 6" a	8' 0" a	12' 11" e	11' 7" e	9' 6" e	12' 8" a	10' 6" a	8' 0" a
800PJ300-68	15' 6"	13' 8" e	11' 2" e	16' 1" i	13' 9" i	10' 11" a	14' 1"	12' 9" e	11' 2" e	15' 10" i	13' 9" i	10' 11" a
800PJ300-97	17' 6"	15' 11"	13' 11"	19' 8" i	17' 11" i	14' 6" i	15' 11"	14' 5"	12' 7"	17' 11" i	16' 3" i	14' 2" i
800PJ300-118	18' 8"	16' 11"	14' 9"	21' 0"	19' 1" i	16' 8" i	16' 11"	15' 5"	13' 5"	19' 1"	17' 4"	15' 1" i
800PJ350-68	15' 9"	13' 10" e	11' 4" e	16' 4" i	13' 11" i	11' 0" a	14' 3"	13' 0" e	11' 4" e	16' 1" i	13' 11" i	11' 0" a
800PJ350-97	18' 0"	16' 4"	14' 3"	20' 2" i	18' 1" i	14' 8" i	16' 4"	14' 10"	12' 11"	18' 4" i	16' 8" i	14' 7" i
800PJ350-118	19' 3"	17' 6"	15' 3"	21' 8" i	19' 8" i	16' 11" i	17' 6"	15' 11"	13' 11"	19' 8"	17' 11" i	15' 7" i
1000PJ250-43	10' 2" e	7' 7" e	5' 1" e	7' 8" a	5' 11" a	4' 0" a	10' 2" e	7' 7" e	5' 1" e	7' 8" a	5' 11" a	4' 0" a
1000PJ250-54	14' 10" e	12' 10" e	10' 1" e	12' 7" a	10' 2" a	7' 3" a	14' 10" e	12' 10" e	10' 1" e	12' 7" a	10' 2" a	7' 3" a
1000PJ250-68	17' 6" e	15' 2" e	12' 5" e	17' 7" i	14' 9" a	11' 5" a	16' 4" e	14' 10" e	12' 5" e	17' 7" i	14' 9" a	11' 5" a
1000PJ250-97	20' 2"	18' 4"	16' 0" e	22' 9" i	20' 8" i	17' 1" i	18' 4"	16' 8"	14' 7"	20' 8" i	18' 9" i	16' 4" i
1000PJ250-118	21' 6"	19' 6"	17' 1"	24' 2" i	22' 0" i	19' 2" i	19' 6"	17' 9"	15' 6"	22' 0"	19' 11" i	17' 5" i
1000PJ300-54	15' 1" e	13' 1" e	10' 1" e	12' 7" a	10' 2" a	7' 4" a	15' 1" e	13' 1" e	10' 1" e	12' 7" a	10' 2" a	7' 4" a
1000PJ300-68	17' 10" e	15' 5" e	12' 7" e	17' 8" i	14' 10" a	11' 5" a	16' 9" e	15' 3" e	12' 7" e	17' 8" i	14' 10" a	11' 5" a
1000PJ300-97	20' 10"	19' 0"	16' 2" e	23' 6" i	20' 8" i	16' 9" i	19' 0"	17' 3"	15' 0"	21' 4" i	19' 5" i	16' 9" i
1000PJ300-118	22' 3"	20' 2"	17' 8"	25' 0" i	22' 9" i	19' 10" i	20' 2"	18' 4"	16' 0"	22' 9"	20' 8" i	18' 0" i
1000PJ350-68	18' 1" e	15' 8" e	12' 9" e	17' 8" i	14' 10" a	11' 5" a	17' 0" e	15' 5" e	12' 9" e	17' 8" i	14' 10" a	11' 5" a
1000PJ350-97	21' 4"	19' 5"	16' 6" e	24' 0" i	20' 10" i	16' 10" i	19' 5"	17' 7"	15' 5" e	21' 10" i	19' 10" i	16' 10" i
1000PJ350-118	22' 11"	20' 10"	18' 2"	25' 9" i	23' 5" i	19' 7" i	20' 10"	18' 11"	16' 6"	23' 5"	21' 3" i	18' 7" i

Floor Systems

Allowable Floor Joist Span Tables

Refer to Important Table Notes on Page 82

40 psf Dead Load and 125 psf Live Load (continued)												
Section (All 50 ksi)	Live Load Deflection L/360						Live Load Deflection L/480					
	Single Span			Two Equal Spans			Single Span			Two Equal Spans		
	Spacing (in.) o.c.			Spacing (in.) o.c.			Spacing (in.) o.c.			Spacing (in.) o.c.		
	12	16	24	12	16	24	12	16	24	12	16	24
1200PJ250-54	16' 3" e	12' 6" e	8' 4" e	11' 9" a	9' 3" a	6' 5" a	16' 3" e	12' 6" e	8' 4" e	11' 9" a	9' 3" a	6' 5" a
1200PJ250-68	19' 3" e	16' 8" e	13' 7" e	17' 6" i	14' 6" a	10' 10" a	18' 8" e	16' 8" e	13' 7" e	17' 6" i	14' 6" a	10' 10" a
1200PJ250-97	23' 4"	21' 2"	17' 6" e	25' 6" i	21' 10" i	17' 6" a	21' 2"	19' 3"	16' 10" e	23' 10" i	21' 8" i	17' 6" a
1200PJ250-118	24' 11"	22' 8"	19' 9"	28' 0" i	25' 1" i	20' 4" i	22' 8"	20' 7"	17' 11"	25' 6" i	23' 2" i	20' 2" i
1200PJ300-54	16' 7" e	12' 6" e	8' 4" e	11' 10" a	9' 3" a	6' 5" a	16' 7" e	12' 6" e	8' 4" e	11' 10" a	9' 3" a	6' 5" a
1200PJ300-68	19' 8" e	17' 0" e	13' 10" e	18' 1" a	14' 11" a	11' 1" a	19' 4" e	17' 0" e	13' 10" e	18' 1" a	14' 11" a	11' 1" a
1200PJ300-97	24' 2"	21' 11"	17' 11" e	26' 11" i	23' 1" i	18' 5" a	21' 11"	19' 11"	17' 5" e	24' 8" i	22' 5" i	18' 5" a
1200PJ300-118	25' 9"	23' 4"	20' 5"	28' 11" i	26' 3" i	22' 4" i	23' 4"	21' 3"	18' 6"	26' 3" i	23' 10" i	20' 10" i
1200PJ350-68	19' 11" e	17' 3" e	14' 1" e	18' 1" a	14' 11" a	11' 1" a	19' 7" e	17' 3" e	14' 1" e	18' 1" a	14' 11" a	11' 1" a
1200PJ350-97	24' 8"	22' 4" e	18' 3" e	27' 1" i	23' 3" i	18' 7" a	22' 5"	20' 4"	17' 9" e	25' 2" i	22' 11" i	18' 7" a
1200PJ350-118	26' 6"	24' 0"	21' 0"	29' 9" i	27' 0" i	22' 0" i	24' 0"	21' 10"	19' 1"	27' 0" i	24' 7" i	21' 5" i
1400PJ250-54	14' 3" e	10' 8" e	7' 1" e	10' 9" i	8' 3" a	5' 7" a	14' 3" e	10' 8" e	7' 1" e	10' 9" i	8' 3" a	5' 7" a
1400PJ250-68	20' 9" e	17' 11" e	14' 3" e	17' 6" a	14' 2" a	10' 3" a	20' 9" e	17' 11" e	14' 3" e	17' 6" a	14' 2" a	10' 3" a
1400PJ250-97	26' 3"	23' 3" e	19' 0" e	27' 4" i	23' 4" i	18' 5" a	23' 10"	21' 8" e	18' 11" e	26' 10" i	23' 4" i	18' 5" a
1400PJ250-118	28' 2"	25' 7"	21' 11" e	31' 9" i	27' 4" i	22' 0" i	25' 7"	23' 3"	20' 4"	28' 10" i	26' 2" i	22' 0" i
1400PJ300-54	14' 3" e	10' 8" e	7' 1" e	10' 9" i	8' 3" a	5' 7" a	14' 3" e	10' 8" e	7' 1" e	10' 9" i	8' 3" a	5' 7" a
1400PJ300-68	21' 2" e	18' 4" e	14' 3" e	17' 8" a	14' 3" a	10' 3" a	21' 2" e	18' 4" e	14' 3" e	17' 8" a	14' 3" a	10' 3" a
1400PJ300-97	27' 1"	23' 10" e	19' 5" e	27' 9" i	23' 8" i	18' 9" a	24' 7"	22' 4" e	19' 5" e	27' 8" i	23' 8" i	18' 9" a
1400PJ300-118	29' 1"	26' 5"	22' 6" e	32' 8" i	28' 2" i	22' 8" i	26' 5"	24' 0"	20' 11"	29' 8" i	27' 0" i	22' 8" i
1400PJ350-68	21' 6" e	18' 8" e	14' 3" e	17' 11" a	14' 5" a	10' 4" a	21' 6" e	18' 8" e	14' 3" e	17' 11" a	14' 5" a	10' 4" a
1400PJ350-97	27' 10"	24' 3" e	19' 9" e	29' 4" i	24' 11" i	19' 8" a	25' 4"	23' 0" e	19' 9" e	28' 6" i	24' 11" i	19' 8" a
1400PJ350-118	29' 11"	27' 2"	22' 11" e	33' 8" i	29' 11" i	24' 1" i	27' 2"	24' 8"	21' 7" e	30' 7" i	27' 9" i	24' 1" i
1600PJ250-68	21' 11" e	18' 8" e	12' 5" e	17' 0" a	13' 5" a	9' 5" a	21' 11" e	18' 8" e	12' 5" e	17' 0" a	13' 5" a	9' 5" a
1600PJ250-97	28' 8" e	24' 10" e	20' 3" e	28' 9" i	24' 4" i	19' 0" a	26' 6"	24' 1" e	20' 3" e	28' 9" i	24' 4" i	19' 0" a
1600PJ250-118	31' 4"	28' 6"	23' 5" e	34' 0" i	29' 2" i	23' 4" i	28' 6"	25' 10"	22' 7" e	32' 0" i	29' 1" i	23' 4" i
1600PJ300-68	22' 6" e	18' 8" e	12' 5" e	17' 1" a	13' 6" a	9' 5" a	22' 6" e	18' 8" e	12' 5" e	17' 1" a	13' 6" a	9' 5" a
1600PJ300-97	29' 5" e	25' 6" e	20' 9" e	29' 2" i	24' 8" i	19' 2" a	27' 3"	24' 9" e	20' 9" e	29' 2" i	24' 8" i	19' 2" a
1600PJ300-118	32' 3"	29' 3"	24' 1" e	35' 0" i	30' 0" i	24' 0" i	29' 3"	26' 7"	23' 3" e	32' 11" i	29' 11" i	24' 0" i
1600PJ350-68	22' 11" e	18' 8" e	12' 5" e	17' 1" a	13' 6" a	9' 5" a	22' 11" e	18' 8" e	12' 5" e	17' 1" a	13' 6" a	9' 5" a
1600PJ350-97	30' 0" e	25' 11" e	21' 2" e	29' 2" i	24' 8" i	19' 2" a	27' 9"	25' 3" e	21' 2" e	29' 2" i	24' 8" i	19' 2" a
1600PJ350-118	33' 1"	30' 1"	24' 7" e	35' 11" i	30' 9" i	24' 7" a	30' 1"	27' 4"	23' 10" e	33' 10" i	30' 9" i	24' 7" a

Important Notes

1. All capacities listed are calculated using AISI S100-16.
2. Web crippling capacities calculated are for studs with stiffened or partially stiffened flanges.
3. Tabulated web crippling capacities are for single members only. For multiple members, multiply the tabulated values by number of members in the assembly.
4. Listed allowable capacities are based on members 'fastened to supports', except back-to-back members under two-flange loading (condition 3 and 4) for which data for 'fastened to support' is unavailable in the AISI S100-16.
5. Listed allowable capacities are for unpunched webs. Capacity reduction for end and interior one flange loading (conditions 1 and 2) near punchouts may be required per Section G6 of AISI S100-16.

Web Crippling Conditions

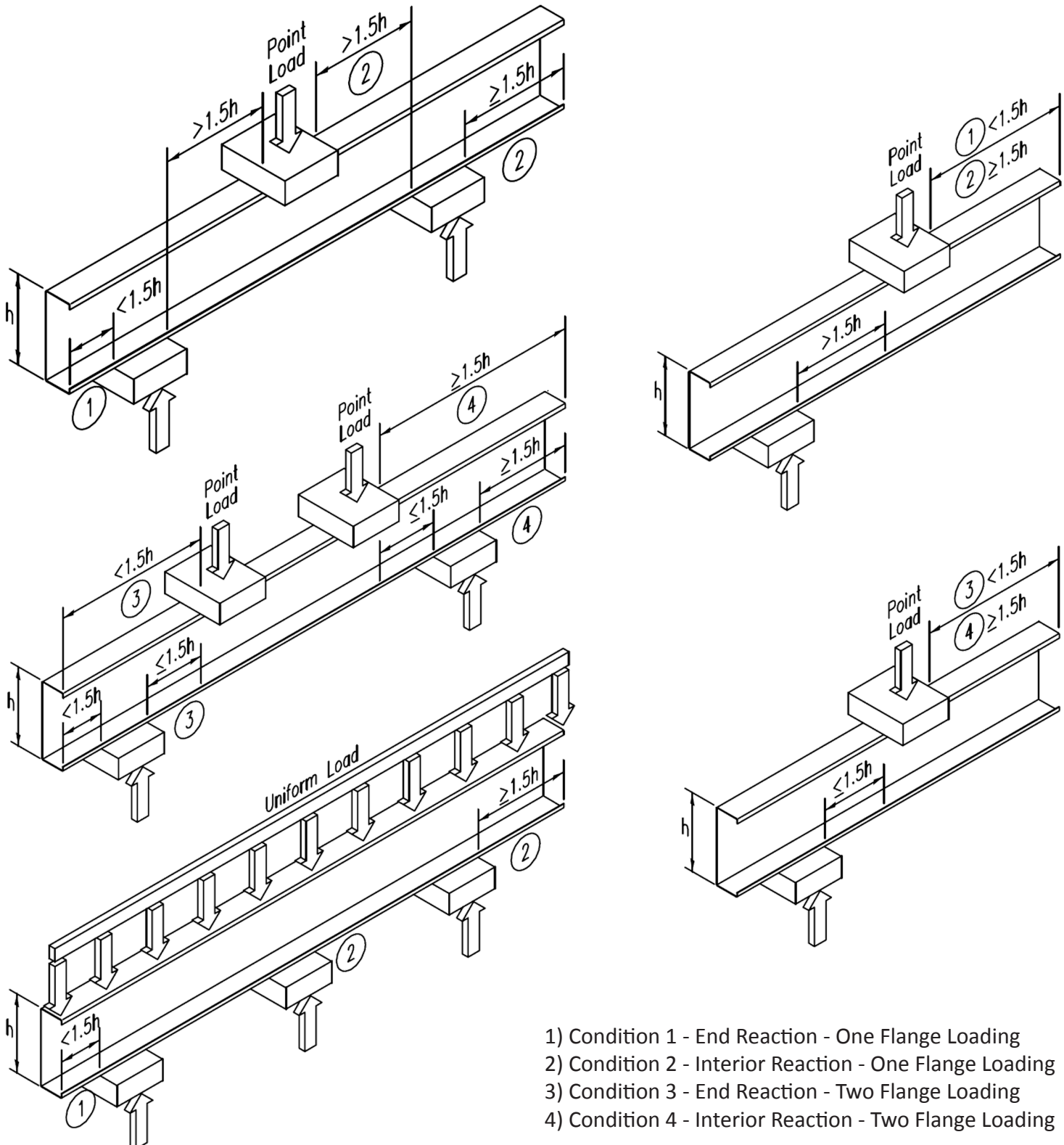

- 1) Condition 1 - End Reaction - One Flange Loading
- 2) Condition 2 - Interior Reaction - One Flange Loading
- 3) Condition 3 - End Reaction - Two Flange Loading
- 4) Condition 4 - Interior Reaction - Two Flange Loading

Refer to Important Table Notes on Page 91

Allowable Web Crippling Loads (lbs) - Single Members																		
Section (All Studs 50ksi)	Design Thick- ness (in.)	Inside Radius (in.)	Condition 1				Condition 2				Condition 3				Condition 4			
			1	3.5	4	6	1	3.5	4	6	1	3.5	4	6	1	3.5	4	6
600PJ250-43	0.0451	0.105	375	579	609	714	766	1031	1070	1207	276	362	375	420	883	1094	1125	1234
600PJ250-54	0.0566	0.105	586	889	934	1091	1239	1638	1698	1904	478	617	638	710	1457	1776	1824	1988
600PJ250-68	0.0713	0.105	916	1369	1436	1669	2005	2605	2694	3004	817	1037	1070	1184	2402	2884	2956	3205
600PJ250-97	0.1017	0.105	1811	2637	2759	3185	4160	5265	5429	5999	1805	2235	2299	2521	5116	6009	6142	6603
600PJ250-118	0.1242	0.105	2652	3803	3974	4568	6248	7795	8024	8823	2789	3406	3497	3816	7787	9042	9228	9876
600PJ300-54	0.0566	0.105	586	889	934	1091	1239	1638	1698	1904	478	617	638	710	1457	1776	1824	1988
600PJ300-68	0.0713	0.105	916	1369	1436	1669	2005	2605	2694	3004	817	1037	1070	1184	2402	2884	2956	3205
600PJ300-97	0.1017	0.105	1811	2637	2759	3185	4160	5265	5429	5999	1805	2235	2299	2521	5116	6009	6142	6603
600PJ300-118	0.1242	0.105	2652	3803	3974	4568	6248	7795	8024	8823	2789	3406	3497	3816	7787	9042	9228	9876
600PJ350-68	0.0713	0.105	916	1369	1436	1669	2005	2605	2694	3004	817	1037	1070	1184	2402	2884	2956	3205
600PJ350-97	0.1017	0.105	1811	2637	2759	3185	4160	5265	5429	5999	1805	2235	2299	2521	5116	6009	6142	6603
600PJ350-118	0.1242	0.105	2652	3803	3974	4568	6248	7795	8024	8823	2789	3406	3497	3816	7787	9042	9228	9876
800PJ250-43	0.0451	0.105	358	551	580	680	750	1010	1048	1182	223	293	304	340	807	999	1027	1127
800PJ250-54	0.0566	0.105	562	853	896	1046	1216	1609	1667	1869	406	524	542	603	1350	1646	1690	1843
800PJ250-68	0.0713	0.105	884	1320	1385	1610	1973	2564	2651	2956	717	911	939	1039	2252	2704	2771	3005
800PJ250-97	0.1017	0.105	1759	2561	2680	3094	4105	5195	5357	5920	1641	2031	2089	2291	4863	5713	5839	6277
800PJ250-118	0.1242	0.105	2584	3706	3872	4451	6173	7702	7929	8718	2570	3138	3222	3516	7449	8649	8827	9446
600PJ300-54	0.0566	0.105	586	889	934	1091	1239	1638	1698	1904	478	617	638	710	1457	1776	1824	1988
600PJ300-68	0.0713	0.105	916	1369	1436	1669	2005	2605	2694	3004	817	1037	1070	1184	2402	2884	2956	3205
600PJ300-97	0.1017	0.105	1811	2637	2759	3185	4160	5265	5429	5999	1805	2235	2299	2521	5116	6009	6142	6603
600PJ300-118	0.1242	0.105	2652	3803	3974	4568	6248	7795	8024	8823	2789	3406	3497	3816	7787	9042	9228	9876
800PJ350-68	0.0713	0.105	884	1320	1385	1610	1973	2564	2651	2956	717	911	939	1039	2252	2704	2771	3005
800PJ350-97	0.1017	0.105	1759	2561	2680	3094	4105	5195	5357	5920	1641	2031	2089	2291	4863	5713	5839	6277
800PJ350-118	0.1242	0.105	2584	3706	3872	4451	6173	7702	7929	8718	2570	3138	3222	3516	7449	8649	8827	9446
1000PJ250-43	0.0451	0.105	342	527	555	651	736	991	1029	1160	177	233	241	270	740	916	942	1033
1000PJ250-54	0.0566	0.105	541	821	863	1007	1197	1583	1640	1839	343	443	458	509	1257	1532	1573	1715
1000PJ250-68	0.0713	0.105	855	1278	1340	1558	1945	2527	2614	2914	630	800	825	913	2121	2547	2610	2830
1000PJ250-97	0.1017	0.105	1714	2495	2610	3013	4057	5134	5294	5851	1496	1853	1906	2089	4643	5453	5574	5992
1000PJ250-118	0.1242	0.105	2525	3620	3783	4348	6108	7621	7845	8626	2378	2904	2982	3254	7153	8305	8476	9071
1000PJ300-54	0.0566	0.105	541	821	863	1007	1197	1583	1640	1839	343	443	458	509	1257	1532	1573	1715
1000PJ300-68	0.0713	0.105	855	1278	1340	1558	1945	2527	2614	2914	630	800	825	913	2121	2547	2610	2830
1000PJ300-97	0.1017	0.105	1714	2495	2610	3013	4057	5134	5294	5851	1496	1853	1906	2089	4643	5453	5574	5992
1000PJ300-118	0.1242	0.105	2525	3620	3783	4348	6108	7621	7845	8626	2378	2904	2982	3254	7153	8305	8476	9071
1000PJ350-68	0.0713	0.105	855	1278	1340	1558	1945	2527	2614	2914	630	800	825	913	2121	2547	2610	2830
1000PJ350-97	0.1017	0.105	1714	2495	2610	3013	4057	5134	5294	5851	1496	1853	1906	2089	4643	5453	5574	5992
1000PJ350-118	0.1242	0.105	2525	3620	3783	4348	6108	7621	7845	8626	2378	2904	2982	3254	7153	8305	8476	9071
1200PJ250-54	0.0566	0.105	522	792	833	972	1179	1559	1616	1812	286	369	382	425	1172	1429	1467	1600
1200PJ250-68	0.0713	0.105	830	1239	1300	1512	1919	2494	2580	2876	551	700	722	799	2003	2405	2465	2672
1200PJ250-97	0.1017	0.105	1673	2435	2548	2941	4013	5080	5238	5788	1367	1692	1740	1908	4444	5220	5335	5736
1200PJ250-118	0.1242	0.105	2471	3543	3703	4256	6050	7548	7770	8543	2206	2693	2766	3018	6886	7996	8160	8733
1200PJ300-54	0.0566	0.105	522	792	833	972	1179	1559	1616	1812	286	369	382	425	1172	1429	1467	1600
1200PJ300-68	0.0713	0.105	830	1239	1300	1512	1919	2494	2580	2876	551	700	722	799	2003	2405	2465	2672
1200PJ300-97	0.1017	0.105	1673	2435	2548	2941	4013	5080	5238	5788	1367	1692	1740	1908	4444	5220	5335	5736
1200PJ300-118	0.1242	0.105	2471	3543	3703	4256	6050	7548	7770	8543	2206	2693	2766	3018	6886	7996	8160	8733
1200PJ350-68	0.0713	0.105	830	1239	1300	1512	1919	2494	2580	2876	551	700	722	799	2003	2405	2465	2672
1200PJ350-97	0.1017	0.105	1673	2435	2548	2941	4013	5080	5238	5788	1367	1692	1740	1908	4444	5220	5335	5736
1200PJ350-118	0.1242	0.105	2471	3543	3703	4256	6050	7548	7770	8543	2206	2693	2766	3018	6886	7996	8160	8733
1400PJ250-54	0.0566	0.105	505	766	805	940	1163	1538	1593	1787	234	302	312	347	1095	1335	1370	1494
1400PJ250-68	0.0713	0.105	806	1204	1263	1469	1896	2464	2548	2842	479	608	627	694	1894	2275	2331	2528
1400PJ250-97	0.1017	0.105	1635	2380	2491	2875	3974	5029	5186	5731	1248	1545	1589	1742	4262	5006	5117	5501
1400PJ250-118	0.1242	0.105	2422	3473	3629	4171	5996	7481	7701	8467	2048	2501	2568	2801	6642	7712	7871	8423
1400PJ300-54	0.0566	0.105	505	766	805	940	1163	1538	1593	1787	234	302	312	347	1095	1335	1370	1494
1400PJ300-68	0.0713	0.105	806	1204	1263	1469	1896	2464	2548	2842	479	608	627	694	1894	2275	2331	2528
1400PJ300-97	0.1017	0.105	1635	2380	2491	2875	3974	5029	5186	5731	1248	1545	1589	1742	4262	5006	5117	5501
1400PJ300-118	0.1242	0.105	2422	3473	3629	4171	5996	7481	7701	8467	2048	2501	2568	2801	6642	7712	7871	8423
1400PJ350-68	0.0713	0.105	806	1204	1263	1469	1896	2464	2548	2842	479	608	627	694	1894	2275	2331	2528
1400PJ350-97	0.1017	0.105	1635	2380	2491	2875	3974	5029	5186	5731	1248	1545	1589	1742	4262	5006	5117	5501
1400PJ350-118	0.1242	0.105	2422	3473	3629	4171	5996	7481	7701	8467	2048	2501	2568	2801	6642	7712	7871	8423

Allowable Web Crippling Loads (lbs) - Single Members (continued)																		
Section (All Studs 50ksi)	Design Thick- ness (in.)	Inside Radius (in.)	Condition 1				Condition 2				Condition 3				Condition 4			
			1	3.5	4	6	1	3.5	4	6	1	3.5	4	6	1	3.5	4	6
1600PJ250-68	0.0713	0.105	784	1172	1229	1429	1875	2436	2519	2809	412	523	540	597	1794	2154	2207	2393
1600PJ250-97	0.1017	0.105	1600	2329	2437	2814	3937	4983	5138	5678	1137	1408	1448	1588	4093	4808	4914	5283
1600PJ250-118	0.1242	0.105	2377	3408	3561	4093	5946	7418	7637	8397	1901	2321	2384	2601	6415	7449	7602	8136
1600PJ300-68	0.0713	0.105	784	1172	1229	1429	1875	2436	2519	2809	412	523	540	597	1794	2154	2207	2393
1600PJ300-97	0.1017	0.105	1600	2329	2437	2814	3937	4983	5138	5678	1137	1408	1448	1588	4093	4808	4914	5283
1600PJ300-118	0.1242	0.105	2377	3408	3561	4093	5946	7418	7637	8397	1901	2321	2384	2601	6415	7449	7602	8136
1600PJ350-68	0.0713	0.105	784	1172	1229	1429	1875	2436	2519	2809	412	523	540	597	1794	2154	2207	2393
1600PJ350-97	0.1017	0.105	1600	2329	2437	2814	3937	4983	5138	5678	1137	1408	1448	1588	4093	4808	4914	5283
1600PJ350-118	0.1242	0.105	2377	3408	3561	4093	5946	7418	7637	8397	1901	2321	2384	2601	6415	7449	7602	8136

Floor Systems

Allowable Web Crippling - Back-to-Back Members

Refer to Important Table Notes on Page 91

Allowable Web Crippling Loads (lbs) - Back-to-Back Members																		
Section (All Studs 50ksi)	Design Thick- ness (in.)	Inside Radius (in.)	Condition 1				Condition 2				Condition 3				Condition 4			
			1	3.5	4	6	1	3.5	4	6	1	3.5	4	6	1	3.5	4	6
(2) 600PJ250-43	0.0451	0.105	917	1371	1438	16721	1324	1718	1776	19791	515	638	656	7191	1091	1351	1389	15231
(2) 600PJ250-54	0.0566	0.105	1397	2055	2152	24921	2087	2662	2747	30441	872	1064	1092	11911	1869	2279	2339	25511
(2) 600PJ250-68	0.0713	0.105	2142	3097	3238	37311	3307	4147	4272	47061	1469	1764	1807	19591	3179	3817	3912	42411
(2) 600PJ250-97	0.1017	0.105	4134	5818	6067	69361	6690	8184	8406	91771	3204	3764	3847	41361	7026	8254	8436	90691
(2) 600PJ250-118	0.1242	0.105	5989	8298	8641	98331	9935	11993	12299	133611	4930	5724	5842	62521	10876	12628	12888	137931
(2) 600PJ250-43	0.0451	0.105	917	1371	1438	16721	1324	1718	1776	19791	515	638	656	7191	1091	1351	1389	15231
(2) 600PJ250-54	0.0566	0.105	1397	2055	2152	24921	2087	2662	2747	30441	872	1064	1092	11911	1869	2279	2339	25511
(2) 600PJ250-68	0.0713	0.105	2142	3097	3238	37311	3307	4147	4272	47061	1469	1764	1807	19591	3179	3817	3912	42411
(2) 600PJ250-97	0.1017	0.105	4134	5818	6067	69361	6690	8184	8406	91771	3204	3764	3847	41361	7026	8254	8436	90691
(2) 600PJ350-68	0.0713	0.105	2142	3097	3238	37311	3307	4147	4272	47061	1469	1764	1807	19591	3179	3817	3912	42411
(2) 600PJ350-97	0.1017	0.105	4134	5818	6067	69361	6690	8184	8406	91771	3204	3764	3847	41361	7026	8254	8436	90691
(2) 600PJ350-118	0.1242	0.105	5989	8298	8641	98331	9935	11993	12299	133611	4930	5724	5842	62521	10876	12628	12888	137931
(2) 800PJ250-43	0.0451	0.105	915	1368	1435	1669	1322	1715	1773	1976	447	553	569	624	946	1171	1205	1321
(2) 800PJ250-54	0.0566	0.105	1395	2051	2149	2487	2084	2658	2743	3039	777	948	973	1061	1666	2031	2085	2273
(2) 800PJ250-68	0.0713	0.105	2139	3092	3234	3726	3302	4141	4266	4699	1336	1604	1644	1782	2891	3472	3558	3857
(2) 800PJ250-97	0.1017	0.105	4129	5810	6060	6927	6682	8174	8396	9166	2981	3502	3579	3848	6537	7679	7848	8437
(2) 800PJ250-118	0.1242	0.105	5983	8289	8631	9822	9924	11980	12285	13346	4630	5377	5487	5872	10216	11861	12106	12955
(2) 800PJ300-54	0.0566	0.105	1395	2051	2149	2487	2084	2658	2743	3039	777	948	973	1061	1666	2031	2085	2273
(2) 800PJ300-68	0.0713	0.105	2139	3092	3234	3726	3302	4141	4266	4699	1336	1604	1644	1782	2891	3472	3558	3857
(2) 800PJ300-97	0.1017	0.105	4129	5810	6060	6927	6682	8174	8396	9166	2981	3502	3579	3848	6537	7679	7848	8437
(2) 800PJ300-118	0.1242	0.105	5983	8289	8631	9822	9924	11980	12285	13346	4630	5377	5487	5872	10216	11861	12106	12955
(2) 800PJ350-68	0.0713	0.105	2139	3092	3234	3726	3302	4141	4266	4699	1336	1604	1644	1782	2891	3472	3558	3857
(2) 800PJ350-97	0.1017	0.105	4129	5810	6060	6927	6682	8174	8396	9166	2981	3502	3579	3848	6537	7679	7848	8437
(2) 800PJ350-118	0.1242	0.105	5983	8289	8631	9822	9924	11980	12285	13346	4630	5377	5487	5872	10216	11861	12106	12955
(2) 1000PJ250-43	0.0451	0.105	914	1366	1433	1667	1320	1712	1770	1972	387	479	493	540	819	1014	1043	1144
(2) 1000PJ250-54	0.0566	0.105	1393	2048	2145	2484	2081	2654	2739	3035	694	846	869	947	1487	1813	1862	2030
(2) 1000PJ250-68	0.0713	0.105	2136	3088	3230	3721	3298	4136	4260	4693	1219	1464	1501	1627	2639	3169	3248	3521
(2) 1000PJ250-97	0.1017	0.105	4125	5804	6053	6920	6675	8165	8387	9156	2786	3272	3345	3596	6109	7176	7334	7884
(2) 1000PJ250-118	0.1242	0.105	5977	8281	8623	9812	9914	11968	12273	13333	4369	5073	5177	5540	9638	11191	11421	12223
(2) 1000PJ300-54	0.0566	0.105	1393	2048	2145	2484	2081	2654	2739	3035	694	846	869	947	1487	1813	1862	2030
(2) 1000PJ300-68	0.0713	0.105	2136	3088	3230	3721	3298	4136	4260	4693	1219	1464	1501	1627	2639	3169	3248	3521
(2) 1000PJ300-97	0.1017	0.105	4125	5804	6053	6920	6675	8165	8387	9156	2786	3272	3345	3596	6109	7176	7334	7884
(2) 1000PJ300-118	0.1242	0.105	5977	8281	8623	9812	9914	11968	12273	13333	4369	5073	5177	5540	9638	11191	11421	12223
(2) 1000PJ350-68	0.0713	0.105	2136	3088	3230	3721	3298	4136	4260	4693	1219	1464	1501	1627	2639	3169	3248	3521
(2) 1000PJ350-97	0.1017	0.105	4125	5804	6053	6920	6675	8165	8387	9156	2786	3272	3345	3596	6109	7176	7334	7884
(2) 1000PJ350-118	0.1242	0.105	5977	8281	8623	9812	9914	11968	12273	13333	4369	5073	5177	5540	9638	11191	11421	12223
(2) 1200PJ250-54	0.0566	0.105	1391	2046	2143	2481	2078	2651	2735	3031	619	755	775	845	1327	1617	1660	1811
(2) 1200PJ250-68	0.0713	0.105	2134	3085	3226	3717	3294	4131	4255	4687	1115	1338	1372	1487	2412	2897	2969	3219
(2) 1200PJ250-97	0.1017	0.105	4121	5798	6047	6913	6668	8158	8378	9147	2610	3066	3134	3369	5723	6723	6871	7387
(2) 1200PJ250-118	0.1242	0.105	5971	8274	8615	9804	9906	11958	12262	13321	4133	4799	4898	5242	9119	10588	10806	11564
(2) 1200PJ300-54	0.0566	0.105	1391	2046	2143	2481	2078	2651	2735	3031	619	755	775	845	1327	1617	1660	1811
(2) 1200PJ300-68	0.0713	0.105	2134	3085	3226	3717	3294	4131	4255	4687	1115	1338	1372	1487	2412	2897	2969	3219
(2) 1200PJ300-97	0.1017	0.105	4121	5798	6047	6913	6668	8158	8378	9147	2610	3066	3134	3369	5723	6723	6871	7387
(2) 1200PJ300-118	0.1242	0.105	5971	8274	8615	9804	9906	11958	12262	13321	4133	4799	4898	5242	9119	10588	10806	11564
(2) 1200PJ350-68	0.0713	0.105	2134	3085	3226	3717	3294	4131	4255	4687	1115	1338	1372	1487	2412	2897	2969	3219
(2) 1200PJ350-97	0.1017	0.105	4121	5798	6047	6913	6668	8158	8378	9147	2610	3066	3134	3369	5723	6723	6871	7387
(2) 1200PJ350-118	0.1242	0.105	5971	8274	8615	9804	9906	11958	12262	13321	4133	4799	4898	5242	9119	10588	10806	11564
(2) 1400PJ250-54	0.0566	0.105	1389	2043	2140	2478	2076	2647	2732	3027	550	671	689	751	1179	1438	1476	1609
(2) 1400PJ250-68	0.0713	0.105	2131	3081	3222	3713	3291	4127	4251	4682	1018	1223	1253	1359	2204	2647	2713	2941
(2) 1400PJ250-97	0.1017	0.105	4117	5793	6042	6907	6662	8150	8371	9139	2449	2877	2940	3161	5370	6308	6447	6931
(2) 1400PJ250-118	0.1242	0.105	5967	8267	8608	9796	9898	11948	12252	13310	3918	4549	4642	4968	8643	10035	10242	10960
(2) 1400PJ300-54	0.0566	0.105	1389	2043	2140	2478	2076	2647	2732	3027	550	671	689	751	1179	1438	1476	1609
(2) 1400PJ300-68	0.0713	0.105	2131	3081	3222	3713	3291	4127	4251	4682	1018	1223	1253	1359	2204	2647	2713	2941
(2) 1400PJ300-97	0.1017	0.105	4117	5793	6042	6907	6662	8150	8371	9139	2449	2877	2940	3161	5370	6308	6447	6931
(2) 1400PJ300-118	0.1242	0.105	5967	8267	8608	9796	9898	11948	12252	13310	3918	4549	4642	4968	8643	10035	10242	10960
(2) 1400PJ350-68	0.0713	0.105	2131	3081	3222	3713	3291	4127	4251	4682	1018	1223	1253	1359	2204	2647	2713	2941
(2) 1400PJ350-97	0.1017	0.105	4117	5793	6042	6907	6662	8150	8371	9139	2449	2877	2940	3161	5370	6308	6447	6931
(2) 1400PJ350-118	0.1242	0.105	5967	8267	8608	9796	9898	11948	12252	13310	3918	4549	4642	4968	8643	10035	10242	10960
(2) 1600PJ250-68	0.0713	0.105	2129	3078	3219	3709	3287	4123	4247	4678	929	1116	1143	1240	2011	2415	2475	2683
(2) 1600PJ250-97	0.1017	0.105	4114	5788	6037	6901	6657	8143	8364	9131	2299	2701	2760	2968	5042	5922	6053	6507
(2) 1600PJ250-118	0.1242	0.105	5962	8261	8602	9788	9890	11939	12243	13300	3717	4316	4405	4714	8201	9522	9718	10400

Refer to Important Table Notes on Page 91

Allowable Web Crippling Loads (lbs) - Back-to-Back Members (continued)																		
Section (All Studs 50ksi)	Design Thick- ness (in.)	Inside Radius (in.)	Condition 1				Condition 2				Condition 3				Condition 4			
			1	3.5	4	6	1	3.5	4	6	1	3.5	4	6	1	3.5	4	6
(2) 1600PJ300-68	0.0713	0.105	2129	3078	3219	3709	3287	4123	4247	4678	929	1116	1143	1240	2011	2415	2475	2683
(2) 1600PJ300-97	0.1017	0.105	4114	5788	6037	6901	6657	8143	8364	9131	2299	2701	2760	2968	5042	5922	6053	6507
(2) 1600PJ300-118	0.1242	0.105	5962	8261	8602	9788	9890	11939	12243	13300	3717	4316	4405	4714	8201	9522	9718	10400
(2) 1600PJ350-68	0.0713	0.105	2129	3078	3219	3709	3287	4123	4247	4678	929	1116	1143	1240	2011	2415	2475	2683
(2) 1600PJ350-97	0.1017	0.105	4114	5788	6037	6901	6657	8143	8364	9131	2299	2701	2760	2968	5042	5922	6053	6507
(2) 1600PJ350-118	0.1242	0.105	5962	8261	8602	9788	9890	11939	12243	13300	3717	4316	4405	4714	8201	9522	9718	10400

¹ Bearing length to web height ratio, N/h, exceeds limit of 1.0.

² Bearing length to thickness ratio, N/t, exceeds limit of 210.

Floor Systems

Floor Joist Framing Solutions

Joist Hangers

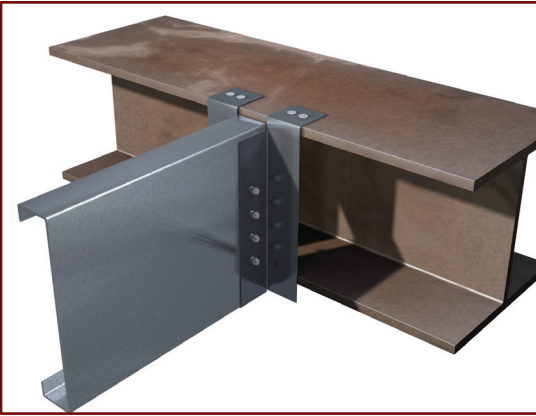

StiffClip® JH: The Steel Network’s StiffClip® JH series represents an ideal method to resist vertical loads. StiffClip JH eliminates the need for joist web stiffener at clip connection. Guide holes are provided for quick and accurate fastener placement. StiffClip JH can be made to accommodate any stud size, but is stocked for use with 6", 8", 10" and 12" stud depths. For allowable load data, see TSN’s *Light Steel Framing Connections Catalog*, or visit www.steelnetwork.com.

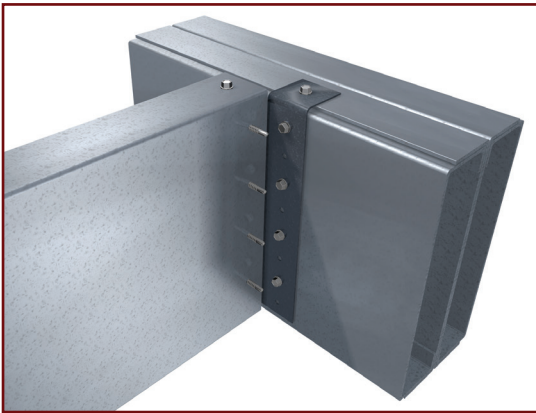

StiffClip® JC: The Steel Network’s StiffClip® JC series connects floor joists to beams and other structural components while resisting vertical loads. Pre-drilled guide holes and a support flange streamline installation. StiffClip JC is available for use with 3 5/8", 6", 8", 10", 12" and 14" stud depths. For allowable load data, see TSN’s *Light Steel Framing Connections Catalog*, or visit www.steelnetwork.com.

Bridging, Blocking & Web Stiffeners



BuckleBridge®: The Steel Network’s BuckleBridge® series provides a solid bridging system to resist weak axis buckling and torsional rotation of members in floor systems. Elongated tabs in one end of BuckleBridge lock into a slot at the other end (through the stud knockout). Two vertical flaps at each end contain predrilled holes to facilitate the attachment to the stud in load bearing applications. BuckleBridge automatically spaces studs at 16" o.c. For allowable load data, see TSN’s *Light Steel Framing Connections Catalog*, or visit www.steelnetwork.com.

Floor Systems

PrimeJoist® Example Details

Double Joist End Bearing

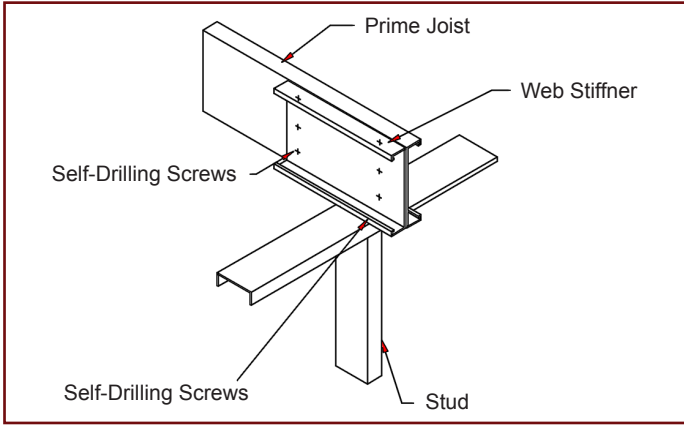

JH, Rigid, Steel Top Flange

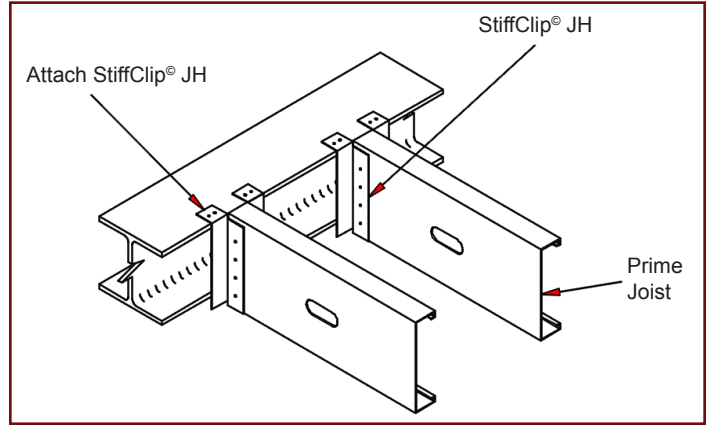

Floor Joist Bridging

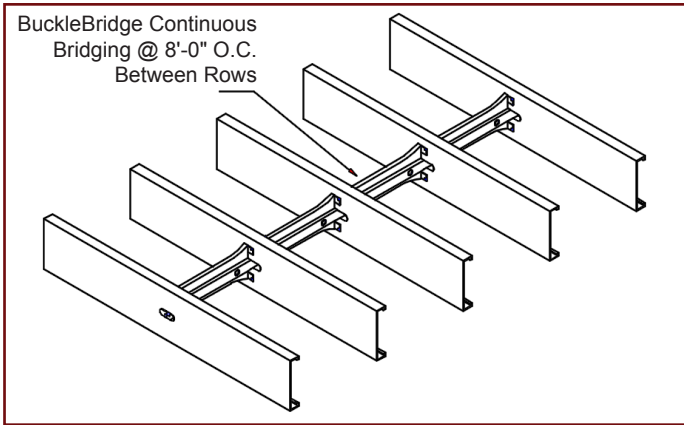

Joist Bearing on LSF Below

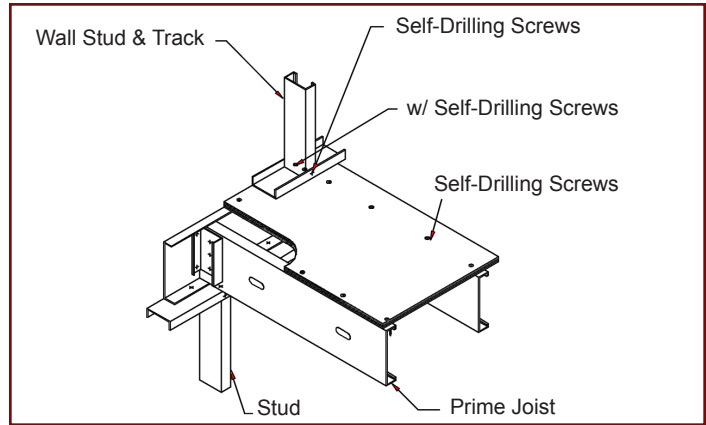

Joist End Web Stiffener, Tight

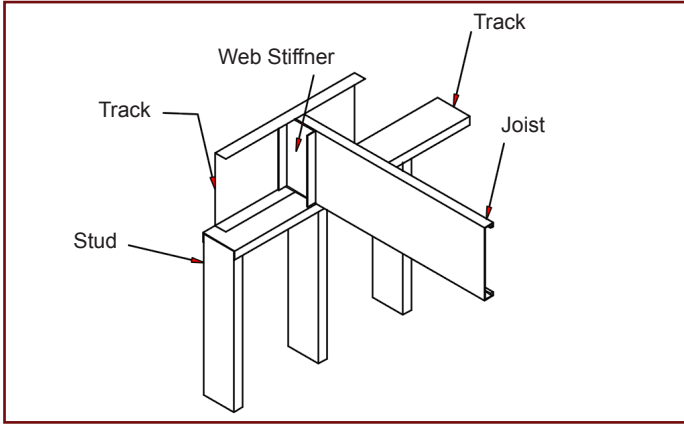

Stair Opening Perpendicular to Joist

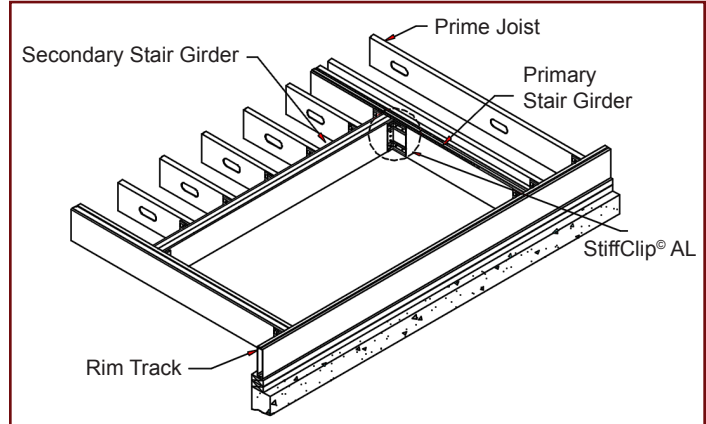

Ledger Framing

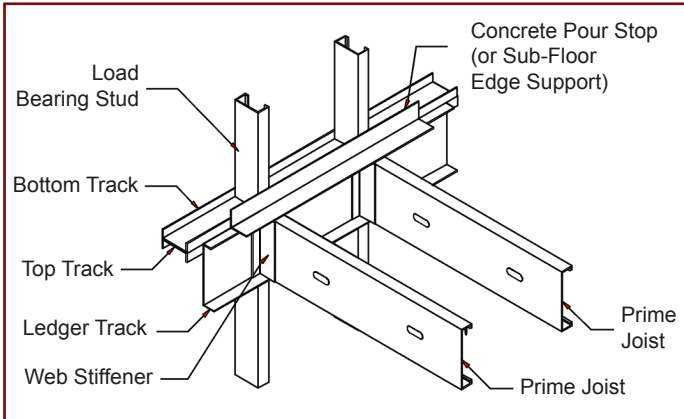

Stair Opening Parallel to Joist

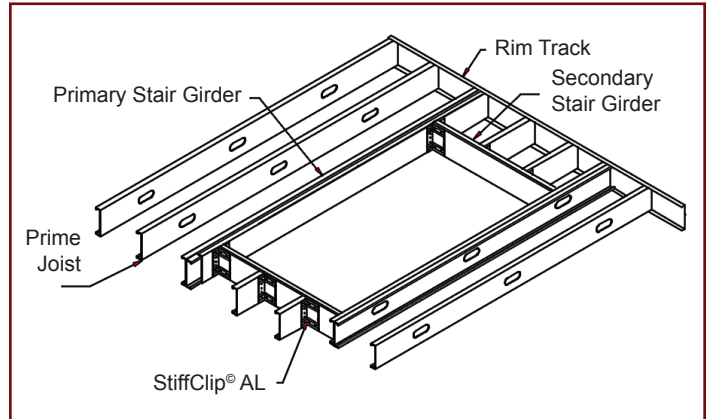

Robust Metal Decking and Concrete Form

SigmaPan®

Material Composition

ASTM A1003/A1003M Structural Grade 50 (340) Type H ST50H (ST340H): 50 ksi (340MPa) minimum yield strength, 65 ksi (450MPa) minimum tensile strength, 33mil minimum thickness (20 gauge, 0.0346" design thickness) with ASTM A653/A653M G60 (Z180) hot dipped galvanized coating.

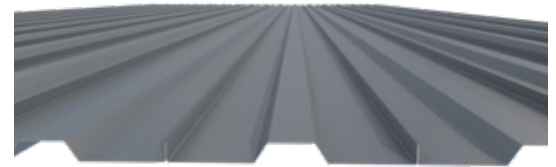

12" Section



16" Section

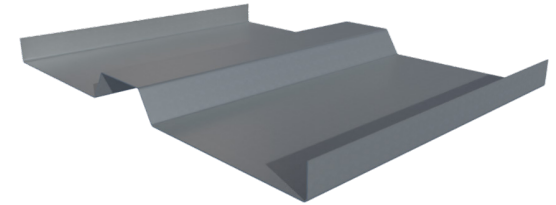

Material Composition

ASTM A1003/A1003M Structural Grade 50 (340) Type H ST50H (ST340H): 50 ksi (340MPa) minimum yield strength, 65 ksi (450MPa) minimum tensile strength, 33mil minimum thickness (20 gauge, 0.0346" design thickness) with ASTM A653/A653M G60 (Z180) hot dipped galvanized coating.

SigmaPan Section Properties																		
Section (All 50 ksi)			Gross Properties						Torsional Properties						Effective Properties			
			Area	I_x	S_x	R_x	I_y	R_y	$Jx1000$	C_w	X_o	m	R_o	β	I_{xe}	S_{xe}	M_{xa}	V_{ag}
			(in ²)	(in ⁴)	(in ³)	(in)	(in ⁴)	(in)	(in ⁴)	(in ⁶)	(in)	(in)	(in)		(in ⁴)	(in ³)	(in-k)	(lb)
1200SGP100-33	0.515	7.319	1.220	3.770	0.082	0.398	0.206	1.343	0.176	0.118	3.795	0.998	6.092	0.728	21.787	361	1143	1240
1600SGP100-33	0.653	15.911	1.989	4.934	0.091	0.373	0.261	2.319	0.124	0.108	4.950	0.999	11.995	0.983	29.421	260	2760	2968

Installation Instructions

Step 1: Install SigmaPan on top of floor support framing.

Step 2: Attach legs of SigmaPan together with specified size and spacing of fasteners.

Step 3: Prior to pouring concrete, attach required edge form work. Block all open joints or holes in metal deck to prevent spillage.

Step 4: Pour Concrete.

Step 1



Step 2

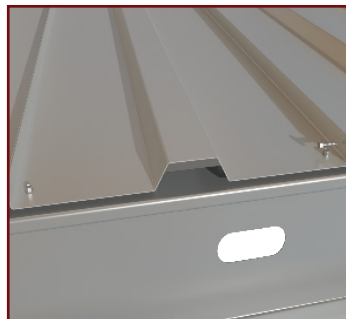

Step 3



Step 4



Nomenclature

SigmaPan is manufactured in two widths and in 12 ft and 24 ft lengths. SigmaPan is designated by depth in inches multiplied by 100, followed by type (SGP), leg size (100), mil thickness (33) and the length.

Example:

1200 SGP 100 - 33 - 12ft
 (Inside Track Dimension) (SigmaPan) (Leg) (Thickness) (Notch Spacing)

* Special lengths available by request.

Product Use

Products in this catalog are designed and manufactured for the specific purposes shown, and should not be used in other applications unless approved by a qualified design professional. All modifications to products or changes in installation procedures should be made by a qualified design professional. The performance of such modified products or altered installation procedures is the sole responsibility of the design professional or installation contractor. The installation contractor and/or qualified design professional are responsible for installing all products in accordance with relevant specifications and building codes.

Customers modifying products or installation procedures, or designing non-standard products for fabrication by The Steel Network, Inc. ("TSN") shall, regardless of specific instructions to the user, indemnify, defend, and hold TSN harmless for any and all claimed loss or damage occasioned in whole or in part by non-standard or modified products or installation procedures.

Loads published on TSN's website and current product catalogs are for the described specific applications of properly installed products. Modifications to TSN products, improper loading or installation procedures, or deviations from recommended applications will affect TSN products' load-carrying capacities. TSN products are fabricated from hot-dipped galvanized steel for corrosion protection but will corrode and lose load-carrying capacity if exposed to salt air, corrosive fire-retardant chemicals, fertilizers, or other substances that may adversely affect steel or its galvanized coating. The current editions of TSN's catalogs and load tables published on this website may reflect changes in the allowable loads and configurations of some of TSN's products. This information supersedes information in earlier catalogs or technical reports. All earlier catalogs or technical reports should be discarded and reference made exclusively to the versions available at <http://www.steelnetwork.com/Site/Catalogs>. TSN may correct any clerical or typographical errors. All sales are subject to TSN's standard terms and conditions of sale.

Limited Warranty

TSN warrants its products to be free from defects in material or workmanship at the time of shipment. TSN standard catalog products are warranted for adequacy of design when used in accordance with design limits in this catalog and properly specified and installed. TSN products shall not be substituted with non-TSN products if it is part of a system. Substitution of a TSN product will immediately void any warranty claim made by Purchaser. This warranty excludes uses not in compliance with specific applications and installation procedures set forth in this catalog. Warranty claims must be made by Purchaser in writing within ninety (90) days of receipt of the products.

All warranty obligations of TSN shall be limited, at the sole discretion of TSN, to repair or replace the defective product(s). These remedies shall constitute TSN's sole obligation and sole remedy of purchaser under this warranty. In no event will TSN be responsible for incidental, consequential, indirect, exemplary, special, or punitive damages, or other losses or damages however caused, including, but not limited to, installation costs, lost revenue or lost profits. TSN's liability for damages shall in no event exceed the applicable portion of the purchase price for defective product(s).

Product defects that arise from acts of God, accidents, misuse, misapplication, improper installation, storage damage, negligence, or modification to product(s) or its components are specifically excluded from this warranty. Product defects that arise from Purchaser providing incorrect information to TSN, including but not limited to incorrect specifications such as incorrect dimensions, designs and/or loads, are also specifically excluded from this warranty. TSN does not authorize any person or party to assume or create for it any other obligation or liability in connection with Products except as set forth herein.

This Warranty is expressly in lieu of all other warranties, expressed or implied, including any warranties of merchantability or fitness for a particular purpose, all such other warranties being hereby expressly excluded.

Patented Technology

BackIt®, BridgeBar®, BridgeClip®, BuckleBridge®, CircleTrak®, DriftClip®, DriftCorner®, DriftTrak®, GripClip®, JamStud®, MidWall™, MasterClip®, NotchTrak®, PrimeWall®, SigmaStud®, SigmaTrak®, Step-Bushing Technology™, StiffClip®, StiffWall®, ThermaFast®, TightStrap®, VertiClip®, and VertiTrack® are trademarked products, and are patented or patent-pending technologies of TSN. Numerous TSN design configurations are patented and/or patent pending and are protected under US and International patent laws. Patent numbers include: #4,970,410; #4,970,411; #4,970,412; #4,970,413; #5,079,710; #5,467,566; #5,904,023; #5,906,080; #6,612,087; #6,701,689; #6,892,504; #7,104,024; #7,503,150; #7,559,519; #7,596,921; #7,634,889; #7,788,878; #7,832,162; #7,836,657; #8,132,383; #8,181,419; #8,205,402; #8,387,321 and #8,683,770.

Contact Information

North Carolina
(Headquarters)
2012-A TW Alexander Blvd
P.O. Box 13887
Durham, NC 27709
Phone: (919) 845-1025
Fax: (888) 474-4877

Texas
600 Lemens Avenue
Suite 120
Hutto, TX 78634
Phone: (512) 642-9603
Fax: (512) 857-1663

Web Site: www.steelnetwork.com
E-mail: support@steelnetwork.com
Toll Free Nationwide Phone
(888) 474-4876



